

### FEATURES

- High output power ( $\Phi_{ep}=20$  W typ.)
- High reliability

### APPLICATIONS

- Laser radar
- Range finder
- Excitation light source



Figure 1: Dimensional Outline (Unit: mm)

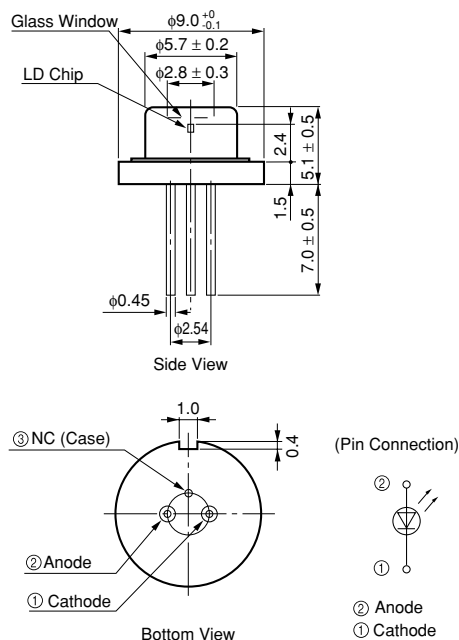

### ABSOLUTE MAXIMUM RATINGS (Top(c)=25 °C)

Parameter	Symbol	Value	Unit
Pulsed Forward Current	I <sub>FP</sub>	25	A
Reverse Voltage	V <sub>r</sub>	2	V
Pulsed Radiant Output Power	$\Phi_{ep}$	30	W
Pulse Duration (FWHM)	t <sub>w</sub>	100	ns
Duty Ratio	DR	0.075	%
Operating Temperature	T <sub>op(c)</sub>	-30 to +85	°C
Storage Temperature	T <sub>stg</sub>	-40 to +125	°C

### ELECTRICAL AND OPTICAL CHARACTERISTICS (Top(c)=25 °C)

Parameter	Symbol	Condition	Min.	Typ.	Max.	Unit
Pulsed Radiant Power	$\Phi_{ep}$	I <sub>FP</sub> =18 A	17	20	-	W
Peak Emission Wavelength	$\lambda_p$		-	870	-	nm
Spectral Radiation Half Bandwidth	$\Delta\lambda_w$	FWHM	-	4	-	nm
Forward Voltage	V <sub>f</sub>	I <sub>FP</sub> =18 A	-	6	-	V
Rise Time	t <sub>r</sub>		-	-	2	ns
Beam Spread Angle : Parallel	$\theta_{//}$	FWHM	7	10	13	degree
: Vertical	$\theta_{\perp}$	I <sub>FP</sub> =18 A	25	30	35	degree
Lasing Threshold Current	I <sub>th</sub>		-	0.6	-	A

# PULSED LASER DIODE L7695-44

Figure 2: Radiant Power vs. Pulsed Forward Current (Typ.)

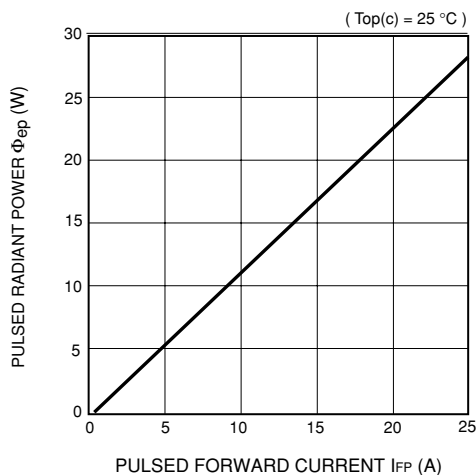

Figure 3: Emission Spectrum (Typ.)

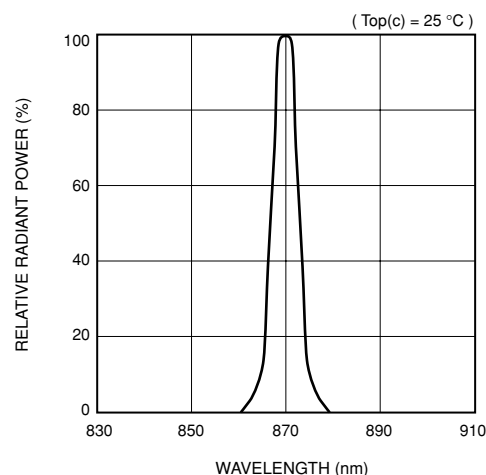
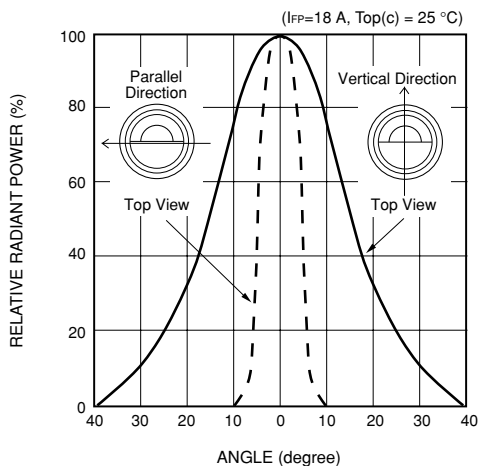

Figure 4: Directivity (Typ.)



## Handling Precautions for L7695-44

### 1. Precautions for handling

The LD (laser diode) may be damaged or its performance may deteriorate due to such factors as electrostatic discharge from the human body, surge voltages from measurement equipment, leakage voltages from soldering irons, and packing materials. As a countermeasure against static electricity, the device, operator, work place and measuring jigs must all be set at the same electric potential. In using LD, observe the following precautions:

- To protect the device from static electricity charges which accumulate on the operator or the operator's clothes, use a wrist strap etc. to ground the operator's body via a high impedance resistor (1 MΩ).

- A semiconductive sheet should be laid on both the work table and the floor in the work area. When soldering, use an electrically grounded soldering iron with an isolation resistance of more than 10 MΩ.

- For containers for transportation and packing, use of antistatic material (material that minimizes the generation of static charge when rubbed against or separated from itself or other similar materials).

### 2. Precautions for mounting

#### (1) Lead forming

To form the leads, hold the base of the leads securely and bend them so that no force is applied to the package. Lead forming should be done before soldering.

#### (2) Cutting off the leads

If leads are cut when still at a high temperature, this may cause an electrical discontinuity. Always cut off the leads when they are at room temperature. Never cut off the leads immediately after they are soldered.

#### (3) Soldering

Using a low-temperature melting solder (below 200 °C), solder the leads at the temperature and dwell time specified as follows.

Maximum Soldering Temperature: 230 °C

Maximum Soldering Time: 5 seconds (1 second for devices having a lead length less than 2 mm)

If these conditions cannot be met, it is recommended that some form of heat sink be used at the base of the lead so that the solder heat is not conducted to the package. Also be careful not to apply excessive force to the leads during soldering.

Soldering at excessive temperatures and dwell times may cause the roots of the leads to crack, resulting in performance deterioration. This sometimes leads to wiring breakage. If the leads are soldered while external force is applied to the device, the residual force tends to degrade device performance. Care should also be taken not to apply force to the leads during soldering.

In addition, when soldering an LD, use a soldering iron with its metallic parts grounded to prevent damage to the device from static discharge.

Do not use any flux which is highly acidic, alkaline or inorganic because it may cause the component leads to erode.

Use a rosin flux.

### 3. Protection against laser beams

The LD is classified into class 3B according to the laser product standards of the IEC825-1 (Radiation safety of laser products Part1: Equipment classification, requirements and user's guide). The operator must avoid eye or skin exposure to the laser beam. When viewing the laser beam, be sure to wear safety goggles that block infrared radiation.

# HAMAMATSU

<http://jp.hamamatsu.com>

HAMAMATSU PHOTONICS K.K., Laser Group, Sales Dept.

5000, Hirakuchi, Hamamatsu City, Shizuoka, 434-8601, Japan, Telephone: (81)53-584-0227, Fax: (81)53-584-0228, E-mail: laser-g@lsr.hp.ko.jp

U.S.A.: Hamamatsu Corporation: 360 Foothill Road, P.O. BOX 6910, Bridgewater, N.J. 08807-0910, U.S.A. Telephone: (1)908-231-0960, Fax: (1)908-231-1218 E-mail: usa@hamamatsu.com

Germany: Hamamatsu Photonics Deutschland GmbH: Arzbergerstr. 10, D-82211 Herrsching am Ammersee, Germany, Telephone: (49)8152-375-0, Fax: (49)8152-2658, E-mail: info@hamamatsu.de

France: Hamamatsu Photonics France S.A.R.L.: 8, Rue du Saule Trapu, Parc du Moulin de Massy, 91882 Massy Cedex, France, Telephone: 33(1) 69 53 71 00, Fax: 33(1) 69 53 71 10, E-mail: infos@hamamatsu.fr

United Kingdom: Hamamatsu Photonics UK Limited: 2 Howard Court, 10 Tewin Road, Welwyn Garden City, Hertfordshire AL7 1BW, United Kingdom, Telephone: (44)1707-294888, Fax: (44)1707-325777, E-mail: info@hamamatsu.co.uk

North Europe: Hamamatsu Photonics Norden AB: Smidesv gen 12, SE-171-41 Solna, Sweden, Telephone: (46)8-509-031-00, Fax: (46)8-509-031-01, E-mail: info@hamamatsu.se

Italy: Hamamatsu Photonics Italia S.R.L.: Strada della Moia, 1/E, 20020 Arese, (Milano), Italy, Telephone: (39)02-935 81 733, Fax: (39)02-935 81 741, E-mail: info@hamamatsu.it

Cat. No. LLD1024E02  
JAN. 2006

Printed in Japan