

ProASIC3 Flash Family FPGAs

with Optional Soft ARM[®] Support



Features and Benefits

High Capacity

- 15 k to 1 M System Gates
- Up to 144 kbits of True Dual-Port SRAM
- Up to 300 User I/Os

Reprogrammable Flash Technology

- 130-nm, 7-Layer Metal (6 Copper), Flash-Based CMOS Process
- Live at Power-Up (LAPU) Level 0 Support
- Single-Chip Solution
- Retains Programmed Design when Powered Off

High Performance

- 350 MHz System Performance
- 3.3 V, 66 MHz 64-Bit PCI[†]

In-System Programming (ISP) and Security

- Secure ISP Using On-Chip 128-Bit Advanced Encryption Standard (AES) Decryption (except ARM[®]-enabled ProASIC[®]3 devices) via JTAG (IEEE 1532-compliant)[†]
- FlashLock[®] to Secure FPGA Contents

Low Power

- Core Voltage for Low Power
- Support for 1.5 V-Only Systems
- Low-Impedance Flash Switches

High-Performance Routing Hierarchy

- Segmented, Hierarchical Routing and Clock Structure

Advanced I/O

- 700 Mbps DDR, LVDS-Capable I/Os (A3P250 and above)

- 1.5 V, 1.8 V, 2.5 V, and 3.3 V Mixed-Voltage Operation
- Bank-Selectable I/O Voltages—up to 4 Banks per Chip
- Single-Ended I/O Standards: LVTTTL, LVCMOS 3.3 V / 2.5 V / 1.8 V / 1.5 V, 3.3 V PCI / 3.3 V PCI-X[†] and LVCMOS 2.5 V / 5.0 V Input
- Differential I/O Standards: LVPECL, LVDS, B-LVDS, and M-LVDS (A3P250 and above)
- I/O Registers on Input, Output, and Enable Paths
- Hot-Swappable and Cold Sparring I/Os[†]
- Programmable Output Slew Rate[†] and Drive Strength
- Weak Pull-Up/-Down
- IEEE 1149.1 (JTAG) Boundary Scan Test
- Pin-Compatible Packages across the ProASIC3 Family

Clock Conditioning Circuit (CCC) and PLL[†]

- Six CCC Blocks, One with an Integrated PLL
- Configurable Phase-Shift, Multiply/Divide, Delay Capabilities and External Feedback
- Wide Input Frequency Range (1.5 MHz to 350 MHz)

Embedded Memory[†]

- 1 kbit of FlashROM User Nonvolatile Memory
- SRAMs and FIFOs with Variable-Aspect-Ratio 4,608-Bit RAM Blocks (x1, x2, x4, x9, and x18 organizations)[†]
- True Dual-Port SRAM (except x18)

ARM Processor Support in ProASIC3 FPGAs

- M1 and M7 ProASIC3 Devices—Cortex-M1 and CoreMP7 Soft Processor Available with or without Debug

ProASIC3 Product Family

ProASIC3 Devices	A3P015	A3P030	A3P060	A3P125	A3P250	A3P400	A3P600	A3P1000
ARM7 Devices ¹								M7A3P1000
Cortex-M1 Devices ¹					M1A3P250	M1A3P400	M1A3P600	M1A3P1000
System Gates	15 k	30 k	60 k	125 k	250 k	400 k	600 k	1 M
Typical Equivalent Macrocells	128	256	512	1,024	–	–	–	–
VersaTiles (D-flip-flops)	384	768	1,536	3,072	6,144	9,216	13,824	24,576
RAM kbits (1,024 bits)	–	–	18	36	36	54	108	144
4,608-Bit Blocks	–	–	4	8	8	12	24	32
FlashROM Bits	1 k	1 k	1 k	1 k	1 k	1 k	1 k	1 k
Secure (AES) ISP ²	–	–	Yes	Yes	Yes	Yes	Yes	Yes
Integrated PLL in CCCs	–	–	1	1	1	1	1	1
VersaNet Globals ³	6	6	18	18	18	18	18	18
I/O Banks	2	2	2	2	4	4	4	4
Maximum User I/Os	49	81	96	133	157	194	235	300
Package Pins								
QFN	QN68	QN132	QN132	QN132	QN132 ⁵			
VQFP		VQ100	VQ100	VQ100	VQ100			
TQFP			TQ144	TQ144				
PQFP			PQ208	PQ208	PQ208	PQ208	PQ208	PQ208
FBGA			FG144	FG144	FG144/256 ⁵	FG144/256/484	FG144/256/484	FG144/256/484

Notes:

1. Refer to the [CoreMP7 datasheet](#) or [Cortex-M1 product brief](#) for more information.
2. AES is not available for ARM-enabled ProASIC3 devices.
3. Six chip (main) and three quadrant global networks are available for A3P060 and above.
4. For higher densities and support of additional features, refer to the [ProASIC3E Flash Family FPGAs handbook](#).
5. The M1A3P250 device does not support this package.

[†] A3P015 and A3P030 devices do not support this feature.

[‡] Supported only by A3P015 and A3P030 devices.

I/Os Per Package¹

ProASIC3 Devices	A3P015	A3P030	A3P060	A3P125	A3P250 ³	A3P400 ³	A3P600	A3P1000				
ARM7 Devices								M7A3P1000				
Cortex-M1 Devices					M1A3P250 ^{3,6}	M1A3P400 ³	M1A3P600	M1A3P1000				
Package	I/O Type											
	Single-Ended I/O	Single-Ended I/O	Single-Ended I/O	Single-Ended I/O	Single-Ended I/O ²	Differential I/O Pairs	Single-Ended I/O ²	Differential I/O Pairs	Single-Ended I/O ²	Differential I/O Pairs	Single-Ended I/O ²	Differential I/O Pairs
QN68	49	-	-	-	-	-	-	-	-	-	-	-
QN132	-	81	80	84	87	19	-	-	-	-	-	-
VQ100	-	77	71	71	68	13	-	-	-	-	-	-
TQ144	-	-	91	100	-	-	-	-	-	-	-	-
PQ208	-	-	-	133	151	34	151	34	154	35	154	35
FG144	-	-	96	97	97	24	97	25	97	25	97	25
FG256	-	-	-	-	157	38	178	38	177	43	177	44
FG484	-	-	-	-	-	-	194	38	235	60	300	74

Notes:

1. When considering migrating your design to a lower- or higher-density device, refer to the [ProASIC3 Flash Family FPGAs handbook](#) to ensure complying with design and board migration requirements.
2. Each used differential I/O pair reduces the number of single-ended I/Os available by two.
3. For A3P250 and A3P400 devices, the maximum number of LVPECL pairs in east and west banks cannot exceed 15. Refer to the [ProASIC3 Flash Family FPGAs handbook](#) for position assignments of the 15 LVPECL pairs.
4. FG256 and FG484 are footprint-compatible packages.
5. "G" indicates RoHS-compliant packages. Refer to "[ProASIC3 Ordering Information](#)" on page III for the location of the "G" in the part number.
6. The M1A3P250 device does not support FG256 or QN132 packages.

Table 1-1 • ProASIC3 FPGAs Package Sizes Dimensions

Package	QN68	QN132	VQ100	TQ144	PQ208	FG144	FG256	FG484
Length × Width (mm\mm)	8 × 8	8 × 8	14 × 14	20 × 20	28 × 28	13 × 13	17 × 17	23 × 23
Nominal Area (mm ²)	64	64	196	400	784	169	289	529
Pitch (mm)	0.4	0.5	0.5	0.5	0.5	1.0	1.0	1.0
Height (mm)	0.90	0.75	1.00	1.40	3.40	1.45	1.60	2.23

ProASIC3 Ordering Information

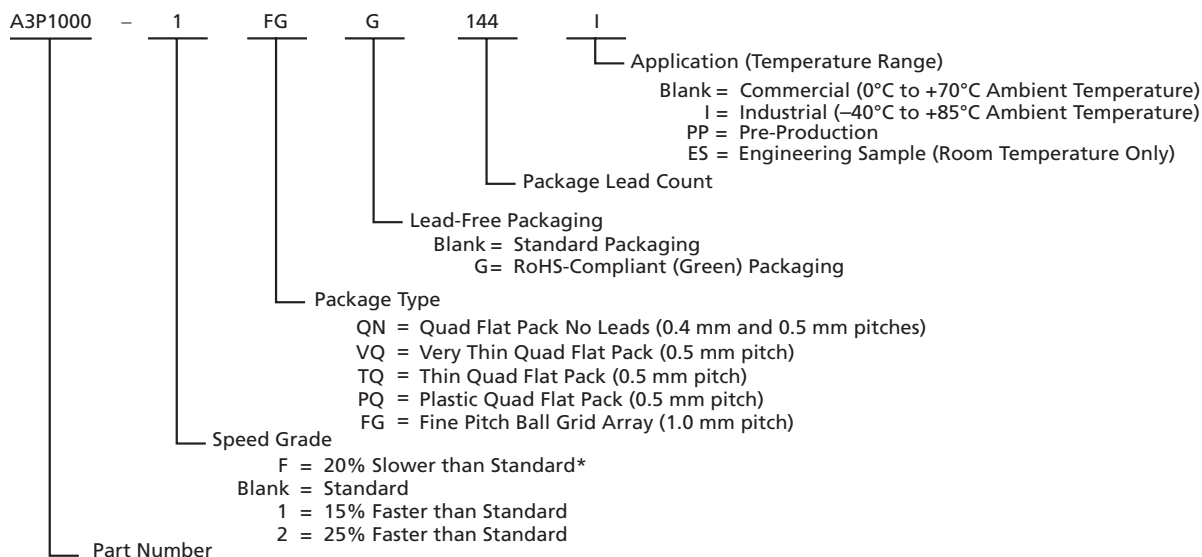

ProASIC3 Devices

A3P015 = 15,000 System Gates
 A3P030 = 30,000 System Gates
 A3P060 = 60,000 System Gates
 A3P125 = 125,000 System Gates
 A3P250 = 250,000 System Gates
 A3P400 = 400,000 System Gates
 A3P600 = 600,000 System Gates
 A3P1000 = 1,000,000 System Gates

ProASIC3 Devices with ARM7

M7A3P1000 = 1,000,000 System Gates

ProASIC3 Devices with Cortex-M1

M1A3P250 = 250,000 System Gates
 M1A3P400 = 400,000 System Gates
 M1A3P600 = 600,000 System Gates
 M1A3P1000 = 1,000,000 System Gates

* The DC and switching characteristics for the -F speed grade targets are based only on simulation. The characteristics provided for the -F speed grade are subject to change after establishing FPGA specifications. Some restrictions might be added and will be reflected in future revisions of this document. The -F speed grade is only supported in the commercial temperature range.

Temperature Grade Offerings

Package	A3P015	A3P030	A3P060	A3P125	A3P250	A3P400	A3P600	A3P1000
ARM7 Devices								M7A3P1000
Cortex-M1 Devices					M1A3P250	M1A3P400	M1A3P600	M1A3P1000
QN68	C, I	-	-	-	-	-	-	-
QN132	-	C, I	C, I	C, I	C, I	-	-	-
VQ100	-	C, I	C, I	C, I	C, I	-	-	-
TQ144	-	-	C, I	C, I	-	-	-	-
PQ208	-	-	-	C, I	C, I	C, I	C, I	C, I
FG144	-	-	C, I	C, I	C, I	C, I	C, I	C, I
FG256	-	-	-	-	C, I	C, I	C, I	C, I
FG484	-	-	-	-	-	C, I	C, I	C, I

Notes:

1. C = Commercial temperature range: 0°C to 70°C ambient temperature
2. I = Industrial temperature range: -40°C to 85°C ambient temperature

Speed Grade and Temperature Grade Matrix

Temperature Grade	-F ¹	Std.	-1	-2
C ²	✓	✓	✓	✓
I ³	-	✓	✓	✓

Notes:

1. The DC and switching characteristics for the -F speed grade targets are based only on simulation. The characteristics provided for the -F speed grade are subject to change after establishing FPGA specifications. Some restrictions might be added and will be reflected in future revisions of this document. The -F speed grade is only supported in the commercial temperature range.
2. C = Commercial temperature range: 0°C to 70°C ambient temperature
3. I = Industrial temperature range: -40°C to 85°C ambient temperature

References made to ProASIC3 devices also apply to ARM-enabled ProASIC3 devices. The ARM-enabled part numbers start with M7 (CoreMP7) and M1 (Cortex-M1).

Contact your local Actel representative for device availability: <http://www.actel.com/contact/default.aspx>.

A3P015 and A3P030

The A3P015 and A3P030 are architecturally compatible; there are no RAM or PLL features.

1 – ProASIC3 Device Family Overview

General Description

ProASIC3, the third-generation family of Actel flash FPGAs, offers performance, density, and features beyond those of the ProASIC^{PLUS} family. Nonvolatile flash technology gives ProASIC3 devices the advantage of being a secure, low-power, single-chip solution that is live at power-up (LAPU). ProASIC3 is reprogrammable and offers time-to-market benefits at an ASIC-level unit cost. These features enable designers to create high-density systems using existing ASIC or FPGA design flows and tools.

ProASIC3 devices offer 1 kbit of on-chip, reprogrammable, nonvolatile FlashROM storage as well as clock conditioning circuitry based on an integrated phase-locked loop (PLL). The A3P015 and A3P030 devices have no PLL or RAM support. ProASIC3 devices have up to 1 million system gates, supported with up to 144 kbits of true dual-port SRAM and up to 300 user I/Os.

ProASIC3 devices support the ARM7 soft IP core and Cortex-M1 devices. The ARM-enabled devices have Actel ordering numbers that begin with M7A3P (CoreMP7) and M1A3P (Cortex-M1) and do not support AES decryption.

Flash Advantages

Reduced Cost of Ownership

Advantages to the designer extend beyond low unit cost, performance, and ease of use. Unlike SRAM-based FPGAs, flash-based ProASIC3 devices allow all functionality to be live at power-up; no external boot PROM is required. On-board security mechanisms prevent access to all the programming information and enable secure remote updates of the FPGA logic. Designers can perform secure remote in-system reprogramming to support future design iterations and field upgrades with confidence that valuable intellectual property (IP) cannot be compromised or copied. Secure ISP can be performed using the industry-standard AES algorithm. The ProASIC3 family device architecture mitigates the need for ASIC migration at higher user volumes. This makes the ProASIC3 family a cost-effective ASIC replacement solution, especially for applications in the consumer, networking/ communications, computing, and avionics markets.

Security

The nonvolatile, flash-based ProASIC3 devices do not require a boot PROM, so there is no vulnerable external bitstream that can be easily copied. ProASIC3 devices incorporate FlashLock, which provides a unique combination of reprogrammability and design security without external overhead, advantages that only an FPGA with nonvolatile flash programming can offer.

ProASIC3 devices utilize a 128-bit flash-based lock and a separate AES key to secure programmed intellectual property and configuration data. In addition, all FlashROM data in ProASIC3 devices can be encrypted prior to loading, using the industry-leading AES-128 (FIPS192) bit block cipher encryption standard. The AES standard was adopted by the National Institute of Standards and Technology (NIST) in 2000 and replaces the 1977 DES standard. ProASIC3 devices have a built-in AES decryption engine and a flash-based AES key that make them the most comprehensive programmable logic device security solution available today. ProASIC3 devices with AES-based security allow for secure, remote field updates over public networks such as the Internet, and ensure that valuable IP remains out of the hands of system overbuilders, system cloners, and IP thieves. The contents of a programmed ProASIC3 device cannot be read back, although secure design verification is possible.

ARM-enabled ProASIC3 devices do not support user-controlled AES security mechanisms. Since the ARM core must be protected at all times, AES encryption is always on for the core logic, so bitstreams are always encrypted. There is no user access to encryption for the FlashROM programming data.

Security, built into the FPGA fabric, is an inherent component of the ProASIC3 family. The flash cells are located beneath seven metal layers, and many device design and layout techniques have been used to make invasive attacks extremely difficult. The ProASIC3 family, with FlashLock and AES security, is unique in being highly resistant to both invasive and noninvasive attacks. Your valuable IP is protected and secure, making remote ISP possible. A ProASIC3 device provides the most impenetrable security for programmable logic designs.

Single Chip

Flash-based FPGAs store their configuration information in on-chip flash cells. Once programmed, the configuration data is an inherent part of the FPGA structure, and no external configuration data needs to be loaded at system power-up (unlike SRAM-based FPGAs). Therefore, flash-based ProASIC3 FPGAs do not require system configuration components such as EEPROMs or microcontrollers to load device configuration data. This reduces bill-of-materials costs and PCB area, and increases security and system reliability.

Live at Power-Up

The Actel flash-based ProASIC3 devices support Level 0 of the LAPU classification standard. This feature helps in system component initialization, execution of critical tasks before the processor wakes up, setup and configuration of memory blocks, clock generation, and bus activity management. The LAPU feature of flash-based ProASIC3 devices greatly simplifies total system design and reduces total system cost, often eliminating the need for CPLDs and clock generation PLLs that are used for these purposes in a system. In addition, glitches and brownouts in system power will not corrupt the ProASIC3 device's flash configuration, and unlike SRAM-based FPGAs, the device will not have to be reloaded when system power is restored. This enables the reduction or complete removal of the configuration PROM, expensive voltage monitor, brownout detection, and clock generator devices from the PCB design. Flash-based ProASIC3 devices simplify total system design and reduce cost and design risk while increasing system reliability and improving system initialization time.

Firm Errors

Firm errors occur most commonly when high-energy neutrons, generated in the upper atmosphere, strike a configuration cell of an SRAM FPGA. The energy of the collision can change the state of the configuration cell and thus change the logic, routing, or I/O behavior in an unpredictable way. These errors are impossible to prevent in SRAM FPGAs. The consequence of this type of error can be a complete system failure. Firm errors do not exist in the configuration memory of ProASIC3 flash-based FPGAs. Once it is programmed, the flash cell configuration element of ProASIC3 FPGAs cannot be altered by high-energy neutrons and is therefore immune to them. Recoverable (or soft) errors occur in the user data SRAM of all FPGA devices. These can easily be mitigated by using error detection and correction (EDAC) circuitry built into the FPGA fabric.

Low Power

Flash-based ProASIC3 devices exhibit power characteristics similar to an ASIC, making them an ideal choice for power-sensitive applications. ProASIC3 devices have only a very limited power-on current surge and no high-current transition period, both of which occur on many FPGAs.

ProASIC3 devices also have low dynamic power consumption to further maximize power savings.

Advanced Flash Technology

The ProASIC3 family offers many benefits, including nonvolatility and reprogrammability through an advanced flash-based, 130-nm LVC MOS process with seven layers of metal. Standard CMOS design techniques are used to implement logic and control functions. The combination of fine granularity, enhanced flexible routing resources, and abundant flash switches allows for very high logic utilization without compromising device routability or performance. Logic functions within the device are interconnected through a four-level routing hierarchy.

Advanced Architecture

The proprietary ProASIC3 architecture provides granularity comparable to standard-cell ASICs. The ProASIC3 device consists of five distinct and programmable architectural features (Figure 1-1 and Figure 1-2 on page 1-4):

- FPGA VersaTiles
- Dedicated FlashROM
- Dedicated SRAM/FIFO memory[†]
- Extensive CCCs and PLLs[†]
- Advanced I/O structure

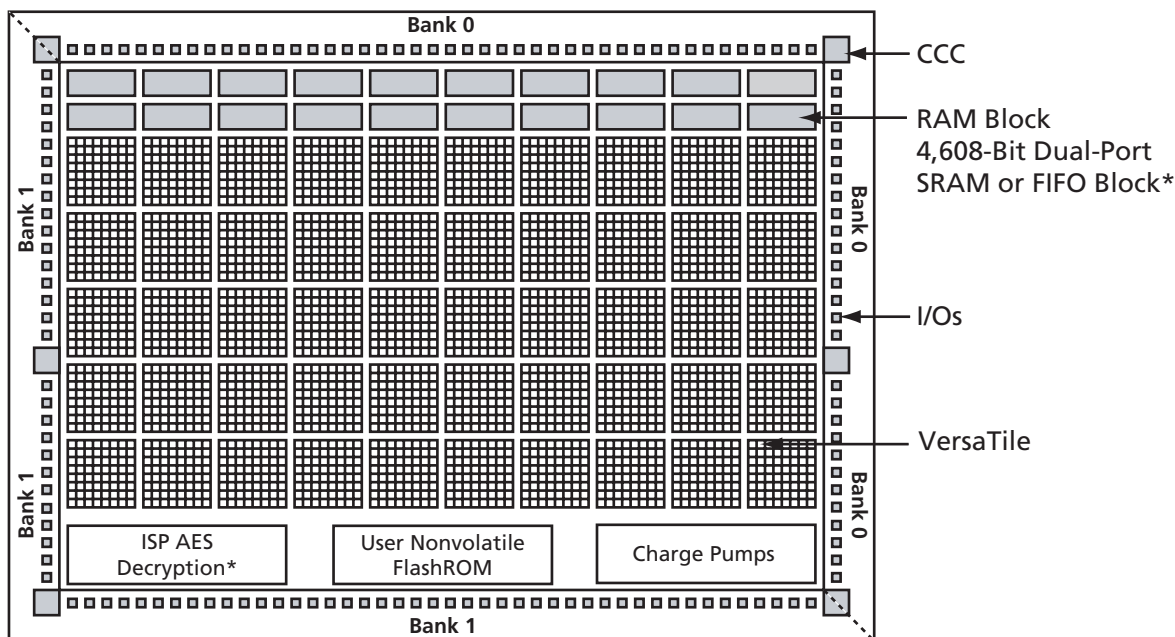

* Not supported by A3P015 and A3P030 devices

Figure 1-1 • ProASIC3 Device Architecture Overview with Two I/O Banks (A3P015, A3P030, A3P060, and A3P125)

[†] The A3P015 and A3P030 do not support PLL or SRAM.

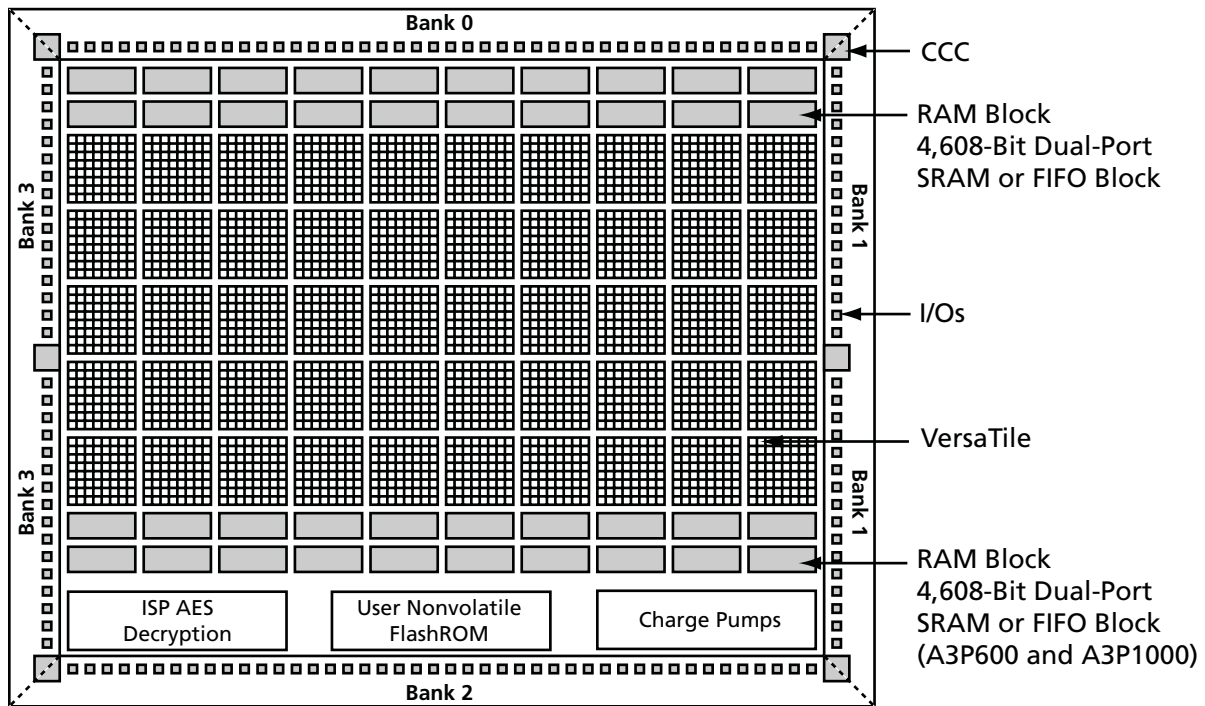

Figure 1-2 • ProASIC3 Device Architecture Overview with Four I/O Banks (A3P250, A3P600, and A3P1000)

The FPGA core consists of a sea of VersaTiles. Each VersaTile can be configured as a three-input logic function, a D-flip-flop (with or without enable), or a latch by programming the appropriate flash switch interconnections. The versatility of the ProASIC3 core tile as either a three-input lookup table (LUT) equivalent or as a D-flip-flop/latch with enable allows for efficient use of the FPGA fabric. The VersaTile capability is unique to the Actel ProASIC family of third-generation architecture flash FPGAs. VersaTiles are connected with any of the four levels of routing hierarchy. Flash switches are distributed throughout the device to provide nonvolatile, reconfigurable interconnect programming. Maximum core utilization is possible for virtually any design.

In addition, extensive on-chip programming circuitry allows for rapid, single-voltage (3.3 V) programming of ProASIC3 devices via an IEEE 1532 JTAG interface.

VersaTiles

The ProASIC3 core consists of VersaTiles, which have been enhanced beyond the ProASIC^{PLUS}® core tiles. The ProASIC3 VersaTile supports the following:

- All 3-input logic functions—LUT-3 equivalent
- Latch with clear or set
- D-flip-flop with clear or set
- Enable D-flip-flop with clear or set

Refer to Figure 1-3 for VersaTile configurations.

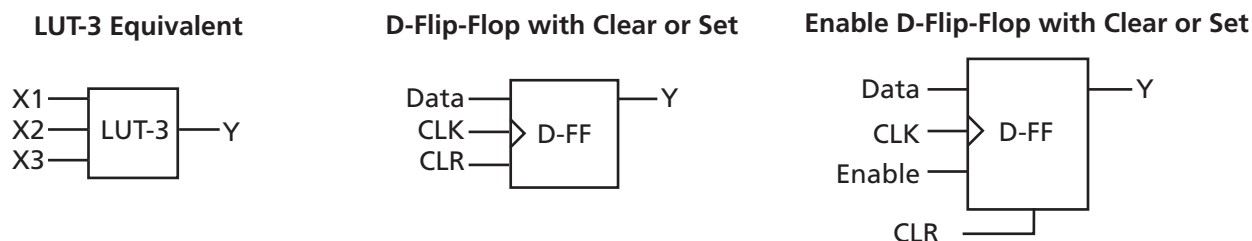

Figure 1-3 • VersaTile Configurations

User Nonvolatile FlashROM

Actel ProASIC3 devices have 1 kbit of on-chip, user-accessible, nonvolatile FlashROM. The FlashROM can be used in diverse system applications:

- Internet protocol addressing (wireless or fixed)
- System calibration settings
- Device serialization and/or inventory control
- Subscription-based business models (for example, set-top boxes)
- Secure key storage for secure communications algorithms
- Asset management/tracking
- Date stamping
- Version management

The FlashROM is written using the standard ProASIC3 IEEE 1532 JTAG programming interface. The core can be individually programmed (erased and written), and on-chip AES decryption can be used selectively to securely load data over public networks (except in the A3P015 and A3P030 devices), as in security keys stored in the FlashROM for a user design.

The FlashROM can be programmed via the JTAG programming interface, and its contents can be read back either through the JTAG programming interface or via direct FPGA core addressing. Note that the FlashROM can only be programmed from the JTAG interface and cannot be programmed from the internal logic array.

The FlashROM is programmed as 8 banks of 128 bits; however, reading is performed on a byte-by-byte basis using a synchronous interface. A 7-bit address from the FPGA core defines which of the 8 banks and which of the 16 bytes within that bank are being read. The three most significant bits (MSBs) of the FlashROM address determine the bank, and the four least significant bits (LSBs) of the FlashROM address define the byte.

The Actel ProASIC3 development software solutions, Libero® Integrated Design Environment (IDE) and Designer, have extensive support for the FlashROM. One such feature is auto-generation of sequential programming files for applications requiring a unique serial number in each part. Another feature allows the inclusion of static data for system version control. Data for the FlashROM can be generated quickly and easily using Actel Libero IDE and Designer software tools. Comprehensive programming file support is also included to allow for easy programming of large numbers of parts with differing FlashROM contents.

SRAM and FIFO

ProASIC3 devices (except the A3P015 and A3P030 devices) have embedded SRAM blocks along their north and south sides. Each variable-aspect-ratio SRAM block is 4,608 bits in size. Available memory configurations are 256×18, 512×9, 1k×4, 2k×2, and 4k×1 bits. The individual blocks have independent read and write ports that can be configured with different bit widths on each port. For example, data can be sent through a 4-bit port and read as a single bitstream. The embedded SRAM blocks can be initialized via the device JTAG port (ROM emulation mode) using the UJTAG macro (except in A3P015 and A3P030 devices).

In addition, every SRAM block has an embedded FIFO control unit. The control unit allows the SRAM block to be configured as a synchronous FIFO without using additional core VersaTiles. The FIFO width and depth are programmable. The FIFO also features programmable Almost Empty (AEMPTY) and Almost Full (AFULL) flags in addition to the normal Empty and Full flags. The embedded FIFO control unit contains the counters necessary for generation of the read and write address pointers. The embedded SRAM/FIFO blocks can be cascaded to create larger configurations.

PLL and CCC

ProASIC3 devices provide designers with very flexible clock conditioning capabilities. Each member of the ProASIC3 family contains six CCCs. One CCC (center west side) has a PLL. The A3P015 and A3P030 devices do not have a PLL.

The six CCC blocks are located at the four corners and the centers of the east and west sides.

All six CCC blocks are usable; the four corner CCCs and the east CCC allow simple clock delay operations as well as clock spine access.

The inputs of the six CCC blocks are accessible from the FPGA core or from one of several inputs located near the CCC that have dedicated connections to the CCC block.

The CCC block has these key features:

- Wide input frequency range (f_{IN_CCC}) = 1.5 MHz to 350 MHz
- Output frequency range (f_{OUT_CCC}) = 0.75 MHz to 350 MHz
- Clock delay adjustment via programmable and fixed delays from -7.56 ns to $+11.12$ ns
- 2 programmable delay types for clock skew minimization
- Clock frequency synthesis (for PLL only)

Additional CCC specifications:

- Internal phase shift = 0° , 90° , 180° , and 270° . Output phase shift depends on the output divider configuration (for PLL only).
- Output duty cycle = $50\% \pm 1.5\%$ or better (for PLL only)
- Low output jitter: worst case $< 2.5\% \times$ clock period peak-to-peak period jitter when single global network used (for PLL only)
- Maximum acquisition time = $300 \mu\text{s}$ (for PLL only)
- Low power consumption of 5 mW
- Exceptional tolerance to input period jitter— allowable input jitter is up to 1.5 ns (for PLL only)
- Four precise phases; maximum misalignment between adjacent phases of $40 \text{ ps} \times (350 \text{ MHz} / f_{OUT_CCC})$ (for PLL only)

Global Clocking

ProASIC3 devices have extensive support for multiple clocking domains. In addition to the CCC and PLL support described above, there is a comprehensive global clock distribution network.

Each VersaTile input and output port has access to nine VersaNets: six chip (main) and three quadrant global networks. The VersaNets can be driven by the CCC or directly accessed from the core via multiplexers (MUXes). The VersaNets can be used to distribute low-skew clock signals or for rapid distribution of high fanout nets.

I/Os with Advanced I/O Standards

The ProASIC3 family of FPGAs features a flexible I/O structure, supporting a range of voltages (1.5 V, 1.8 V, 2.5 V, and 3.3 V). ProASIC3 FPGAs support many different I/O standards—single-ended and differential.

The I/Os are organized into banks, with two or four banks per device. The configuration of these banks determines the I/O standards supported.

Each I/O module contains several input, output, and enable registers. These registers allow the implementation of the following:

- Single-Data-Rate applications
- Double-Data-Rate applications—DDR LVDS, B-LVDS, and M-LVDS I/Os for point-to-point communications

ProASIC3 banks for the A3P250 device and above support LVPECL, LVDS, B-LVDS and M-LVDS. B-LVDS and M-LVDS can support up to 20 loads.

Part Number and Revision Date

Part Number 51700097-001-1

Revised February 2008

List of Changes

The following table lists critical changes that were made in the current version of the document.

Previous Version	Changes in Current Version (v1.0)	Page
51700097-001-1	This document was divided into two sections and given a version number, starting at v1.0. The first section of the document includes features, benefits, ordering information, and temperature and speed grade offerings. The second section is a device family overview.	
51700097-001-0 (January 2008)	This document was updated to include A3P015 device information. QN68 is a new package that was added because it is offered in the A3P015. The following sections were updated: "Features and Benefits" "ProASIC3 Ordering Information" "Temperature Grade Offerings" "ProASIC3 Product Family" "A3P015 and A3P030" note "Introduction and Overview"	N/A
	The "ProASIC3 FPGAs Package Sizes Dimensions" table is new.	II
	In the "ProASIC3 Ordering Information", the QN package measurements were updated to include both 0.4 mm and 0.5 mm.	III
	In the "General Description" section, the number of I/Os was updated from 288 to 300.	1-1
v2.2 (July 2007)	This document was previously in datasheet v2.2. As a result of moving to the handbook format, Actel has restarted the version numbers. The new version number is 51700097-001-0.	N/A

Previous Version	Changes in Current Version (v1.0)	Page							
v2.1 (May 2007)	The M7 and M1 device part numbers have been updated in Table 1 • ProASIC3 Product Family, "I/Os Per Package", "Automotive ProASIC3 Ordering Information", "Temperature Grade Offerings", and "Speed Grade and Temperature Grade Matrix".	i, ii, iii, iii, iv							
	The words "ambient temperature" were added to the temperature range in the "Automotive ProASIC3 Ordering Information", "Temperature Grade Offerings", and "Speed Grade and Temperature Grade Matrix" sections.	iii, iii, iv							
v2.0 (April 2007)	In the "Clock Conditioning Circuit (CCC) and PLL" section, the Wide Input Frequency Range (1.5 MHz to 200 MHz) was changed to (1.5 MHz to 350 MHz).	i							
	The "Clock Conditioning Circuit (CCC) and PLL" section was updated.	i							
	In the "I/Os Per Package" section, the A3P030, A3P060, A3P125, ACP250, and A3P600 device I/Os were updated.	ii							
Advance v0.7 (January 2007)	In the "Packaging Tables", Ambient was deleted.	ii							
	Ambient was deleted from the "Speed Grade and Temperature Grade Matrix".	iv							
Advance v0.6 (April 2006)	In the "I/Os Per Package" table, the I/O numbers were added for A3P060, A3P125, and A3P250. The A3P030-VQ100 I/O was changed from 79 to 77.	ii							
Advance v0.5 (January 2006)	B-LVDS and M-LDVS are new I/O standards added to the datasheet.	N/A							
	The term flow-through was changed to pass-through.	N/A							
	Table 1 was updated to include the QN132.	ii							
	The "I/Os Per Package" table was updated with the QN132. The footnotes were also updated. The A3P400-FG144 I/O count was updated.	ii							
	"Automotive ProASIC3 Ordering Information" was updated with the QN132.	iii							
	"Temperature Grade Offerings" was updated with the QN132.	iii							
Advance v0.4 (November 2005)	The "I/Os Per Package" table was updated for the following devices and packages:	ii							
	<table border="0"> <thead> <tr> <th>Device</th> <th>Package</th> </tr> </thead> <tbody> <tr> <td>A3P250/M7ACP250</td> <td>VQ100</td> </tr> <tr> <td>A3P250/M7ACP250</td> <td>FG144</td> </tr> <tr> <td>A3P1000</td> <td>FG256</td> </tr> </tbody> </table>	Device	Package	A3P250/M7ACP250	VQ100	A3P250/M7ACP250	FG144	A3P1000	FG256
Device	Package								
A3P250/M7ACP250	VQ100								
A3P250/M7ACP250	FG144								
A3P1000	FG256								
Advance v0.3	M7 device information is new.	N/A							
	The I/O counts in the "I/Os Per Package" table were updated.	ii							
Advance v0.2	The "I/Os Per Package" table was updated.	ii							

Datasheet Categories

Categories

In order to provide the latest information to designers, some datasheets are published before data has been fully characterized. Datasheets are designated as "Product Brief," "Advance," "Preliminary," and "Production." The definition of these categories are as follows:

Product Brief

The product brief is a summarized version of a datasheet (advance or production) and contains general product information. This document gives an overview of specific device and family information.

Advance

This version contains initial estimated information based on simulation, other products, devices, or speed grades. This information can be used as estimates, but not for production. This label only applies to the DC and Switching Characteristics chapter of the datasheet and will only be used when the data has not been fully characterized.

Preliminary

The datasheet contains information based on simulation and/or initial characterization. The information is believed to be correct, but changes are possible.

Unmarked (production)

This version contains information that is considered to be final.

Export Administration Regulations (EAR)

The products described in this document are subject to the Export Administration Regulations (EAR). They could require an approved export license prior to export from the United States. An export includes release of product or disclosure of technology to a foreign national inside or outside the United States.

Actel Safety Critical, Life Support, and High-Reliability Applications Policy

The Actel products described in this advance status document may not have completed Actel's qualification process. Actel may amend or enhance products during the product introduction and qualification process, resulting in changes in device functionality or performance. It is the responsibility of each customer to ensure the fitness of any Actel product (but especially a new product) for a particular purpose, including appropriateness for safety-critical, life-support, and other high-reliability applications. Consult Actel's Terms and Conditions for specific liability exclusions relating to life-support applications. A reliability report covering all of Actel's products is available on the Actel website at http://www.actel.com/documents/ORT_Report.pdf. Actel also offers a variety of enhanced qualification and lot acceptance screening procedures. Contact your local Actel sales office for additional reliability information.



2 – ProASIC3 DC and Switching Characteristics

General Specifications

DC and switching characteristics for –F speed grade targets are based only on simulation.

The characteristics provided for the –F speed grade are subject to change after establishing FPGA specifications. Some restrictions might be added and will be reflected in future revisions of this document. The –F speed grade is only supported in the commercial temperature range.

Operating Conditions

Stresses beyond those listed in [Table 2-1](#) may cause permanent damage to the device.

Exposure to absolute maximum rating conditions for extended periods may affect device reliability. Absolute Maximum Ratings are stress ratings only; functional operation of the device at these or any other conditions beyond those listed under the Recommended Operating Conditions specified in [Table 2-2](#) on [page 2-2](#) is not implied.

Table 2-1 • Absolute Maximum Ratings

Symbol	Parameter	Limits	Units
V _{CC}	DC core supply voltage	–0.3 to 1.65	V
V _{JTAG}	JTAG DC voltage	–0.3 to 3.75	V
V _{PUMP}	Programming voltage	–0.3 to 3.75	V
V _{CCPLL}	Analog power supply (PLL)	–0.3 to 1.65	V
V _{CCI}	DC I/O output buffer supply voltage	–0.3 to 3.75	V
VMV	DC I/O input buffer supply voltage	–0.3 to 3.75	V
V _I	I/O input voltage	–0.3 V to 3.6 V (when I/O hot insertion mode is enabled) –0.3 V to (V _{CCI} + 1 V) or 3.6 V, whichever voltage is lower (when I/O hot-insertion mode is disabled)	V
T _{STG} ²	Storage temperature	–65 to +150	°C
T _J ²	Junction temperature	+125	°C

Notes:

1. The device should be operated within the limits specified by the datasheet. During transitions, the input signal may undershoot or overshoot according to the limits shown in [Table 2-4](#) on [page 2-3](#).
2. For flash programming and retention maximum limits, refer to [Table 2-3](#) on [page 2-2](#), and for recommended operating limits, refer to [Table 2-2](#) on [page 2-2](#).

Table 2-2 • Recommended Operating Conditions ¹

Symbol	Parameter	Commercial	Industrial	Units	
T _A	Ambient temperature	0 to +70 ^{4,6}	-40 to +85 ^{5,6}	°C	
V _{CC}	1.5 V DC core supply voltage	1.425 to 1.575	1.425 to 1.575	V	
V _{JTAG}	JTAG DC voltage	1.4 to 3.6	1.4 to 3.6	V	
V _{PUMP}	Programming voltage	Programming Mode	3.15 to 3.45	3.15 to 3.45	V
		Operation ³	0 to 3.6	0 to 3.6	V
V _{CCPLL}	Analog power supply (PLL)	1.4 to 1.6	1.4 to 1.6	V	
V _{CCI} and VMV ²	1.5 V DC supply voltage	1.425 to 1.575	1.425 to 1.575	V	
	1.8 V DC supply voltage	1.7 to 1.9	1.7 to 1.9	V	
	2.5 V DC supply voltage	2.3 to 2.7	2.3 to 2.7	V	
	3.3 V DC supply voltage	3.0 to 3.6	3.0 to 3.6	V	
	LVDS/B-LVDS/M-LVDS differential I/O	2.375 to 2.625	2.375 to 2.625	V	
	LVPECL differential I/O	3.0 to 3.6	3.0 to 3.6	V	

Notes:

1. All parameters representing voltages are measured with respect to GND unless otherwise specified.
2. The ranges given here are for power supplies only. The recommended input voltage ranges specific to each I/O standard are given in Table 2-18 on page 2-19. VMV and V_{CCI} should be at the same voltage within a given I/O bank.
3. V_{PUMP} can be left floating during operation (not programming mode).
4. Maximum T_J = 85°C.
5. Maximum T_J = 100°C.
6. To ensure targeted reliability standards are met across ambient and junction operating temperatures, Actel recommends that the user follow best design practices using Actel's timing and power simulation tools.

Table 2-3 • Flash Programming Limits – Retention, Storage and Operating Temperature¹

Product Grade	Programming Cycles	Program Retention (biased/unbiased)	Maximum Storage Temperature T _{STG} (°C) ²	Maximum Operating Junction Temperature T _J (°C) ²
Commercial	500	20 years	110	100
Industrial	500	20 years	110	100

Notes:

1. This is a stress rating only; functional operation at any condition other than those indicated is not implied.
2. These limits apply for program/data retention only. Refer to Table 2-1 on page 2-1 and Table 2-2 for device operating conditions and absolute limits.

Table 2-4 • Overshoot and Undershoot Limits¹

V _{CCI} and VMV	Average V _{CCI} -GND Overshoot or Undershoot Duration as a Percentage of Clock Cycle ²	Maximum Overshoot/Undershoot ²
2.7 V or less	10%	1.4 V
	5%	1.49 V
3 V	10%	1.1 V
	5%	1.19 V
3.3 V	10%	0.79 V
	5%	0.88 V
3.6 V	10%	0.45 V
	5%	0.54 V

Notes:

1. Based on reliability requirements at 85°C.
2. The duration is allowed at one out of six clock cycles. If the overshoot/undershoot occurs at one out of two cycles, the maximum overshoot/undershoot has to be reduced by 0.15 V.
3. This table does not provide PCI overshoot/undershoot limits.

I/O Power-Up and Supply Voltage Thresholds for Power-On Reset (Commercial and Industrial)

Sophisticated power-up management circuitry is designed into every ProASIC®3 device. These circuits ensure easy transition from the powered-off state to the powered-up state of the device. The many different supplies can power up in any sequence with minimized current spikes or surges. In addition, the I/O will be in a known state through the power-up sequence. The basic principle is shown in [Figure 2-1 on page 2-4](#).

There are five regions to consider during power-up.

ProASIC3 I/Os are activated only if ALL of the following three conditions are met:

1. V_{CC} and V_{CCI} are above the minimum specified trip points ([Figure 2-1 on page 2-4](#)).
2. V_{CCI} > V_{CC} - 0.75 V (typical)
3. Chip is in the operating mode.

V_{CCI} Trip Point:

Ramping up: 0.6 V < trip_point_up < 1.2 V

Ramping down: 0.5 V < trip_point_down < 1.1 V

V_{CC} Trip Point:

Ramping up: 0.6 V < trip_point_up < 1.1 V

Ramping down: 0.5 V < trip_point_down < 1 V

V_{CC} and V_{CCI} ramp-up trip points are about 100 mV higher than ramp-down trip points. This specifically built-in hysteresis prevents undesirable power-up oscillations and current surges. Note the following:

- During programming, I/Os become tristated and weakly pulled up to V_{CCI}.
- JTAG supply, PLL power supplies, and charge pump V_{PUMP} supply have no influence on I/O behavior.

PLL Behavior at Brownout Condition

Actel recommends using monotonic power supplies or voltage regulators to ensure proper power-up behavior. Power ramp-up should be monotonic at least until V_{CC} and V_{CCPLLX} exceed brownout activation levels. The V_{CC} activation level is specified as 1.1 V worst-case (see [Figure 2-1 on page 2-4](#) for more details).

When PLL power supply voltage and/or V_{CC} levels drop below the V_{CC} brownout levels (0.75 V ± 0.25 V), the PLL output lock signal goes low and/or the output clock is lost. Refer to the

Power-Up/Down Behavior of Low-Power Flash Devices chapter of the handbook for information on clock and lock recovery.

Internal Power-Up Activation Sequence

1. Core
2. Input buffers

Output buffers, after 200 ns delay from input buffer activation

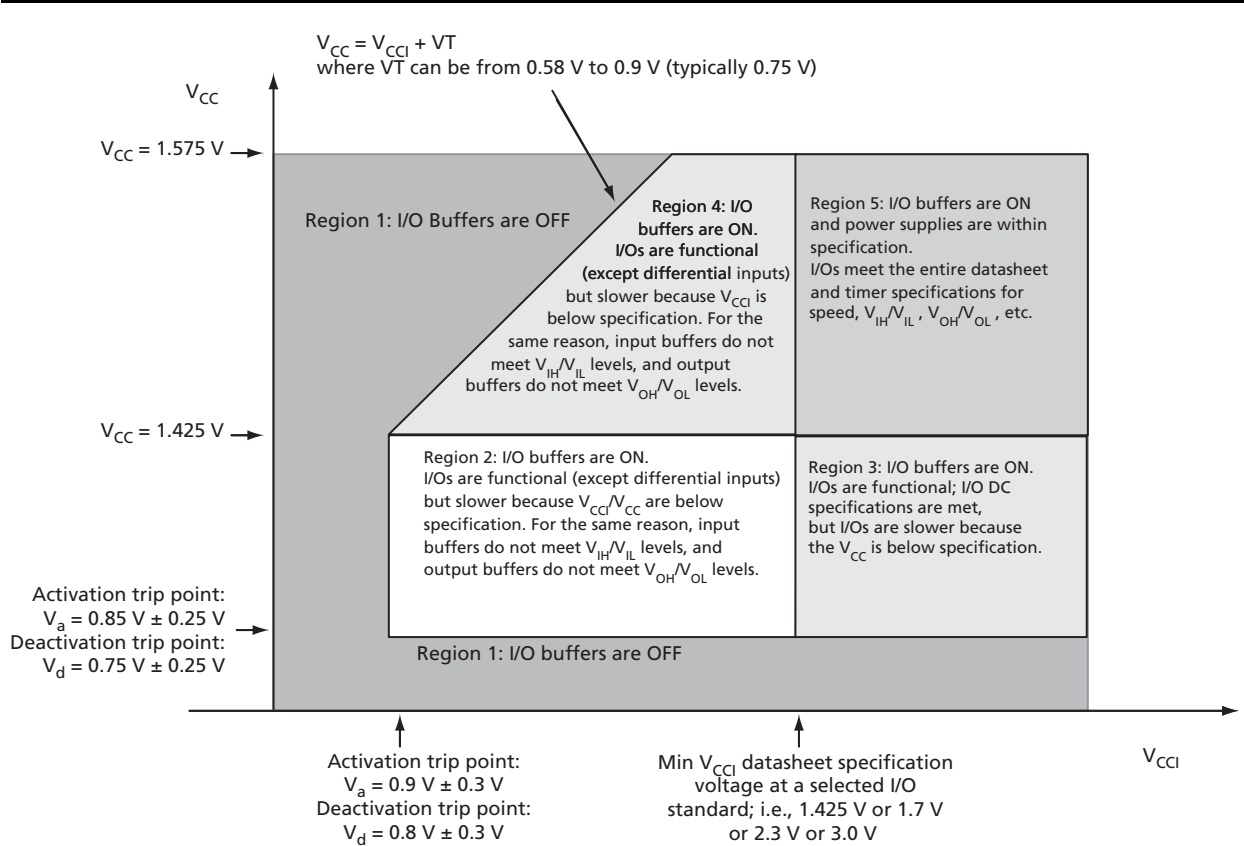

Figure 2-1 • I/O State as a Function of V_{CCI} and V_{CC} Voltage Levels

Thermal Characteristics

Introduction

The temperature variable in the Actel Designer software refers to the junction temperature, not the ambient temperature. This is an important distinction because dynamic and static power consumption cause the chip junction to be higher than the ambient temperature.

EQ 2-1 can be used to calculate junction temperature.

$$T_J = \text{Junction Temperature} = \Delta T + T_A$$

EQ 2-1

where:

T_A = Ambient Temperature

ΔT = Temperature gradient between junction (silicon) and ambient $\Delta T = \theta_{ja} * P$

θ_{ja} = Junction-to-ambient of the package. θ_{ja} numbers are located in Table 2-5.

P = Power dissipation

Package Thermal Characteristics

The device junction-to-case thermal resistivity is θ_{jc} and the junction-to-ambient air thermal resistivity is θ_{ja} . The thermal characteristics for θ_{ja} are shown for two air flow rates. The absolute maximum junction temperature is 100°C. EQ 2-2 shows a sample calculation of the absolute maximum power dissipation allowed for a 484-pin FBGA package at commercial temperature and in still air.

$$\text{Maximum Power Allowed} = \frac{\text{Max. junction temp. (}^\circ\text{C)} - \text{Max. ambient temp. (}^\circ\text{C)}}{\theta_{ja} (^\circ\text{C/W)}} = \frac{100^\circ\text{C} - 70^\circ\text{C}}{20.5^\circ\text{C/W}} = 1.463 \text{ W}$$

EQ 2-2

Table 2-5 • Package Thermal Resistivities

Package Type	Device	Pin Count	θ_{jc}	θ_{ja}			Units
				Still Air	200 ft./min.	500 ft./min.	
Quad Flat No Lead	A3P030	132	0.4	21.4	16.8	15.3	C/W
	A3P060	132	0.3	21.2	16.6	15.0	C/W
	A3P125	132	0.2	21.1	16.5	14.9	C/W
	A3P250	132	0.1	21.0	16.4	14.8	C/W
Very Thin Quad Flat Pack (VQFP)	All devices	100	10.0	35.3	29.4	27.1	C/W
Thin Quad Flat Pack (TQFP)	All devices	144	11.0	33.5	28.0	25.7	C/W
Plastic Quad Flat Pack (PQFP)	All devices	208	8.0	26.1	22.5	20.8	C/W
PQFP with embedded heatspreader	All devices	208	3.8	16.2	13.3	11.9	C/W
Fine Pitch Ball Grid Array (FBGA)	See note*	144	3.8	26.9	22.9	21.5	C/W
	See note*	256	3.8	26.6	22.8	21.5	C/W
	See note*	484	3.2	20.5	17.0	15.9	C/W
	A3P1000	144	6.3	31.6	26.2	24.2	C/W
	A3P1000	256	6.6	28.1	24.4	22.7	C/W
	A3P1000	484	8.0	23.3	19.0	16.7	C/W

* This information applies to all ProASIC3 devices except the A3P1000. Detailed device/package thermal information will be available in future revisions of the datasheet.

Temperature and Voltage Derating Factors

Table 2-6 • Temperature and Voltage Derating Factors for Timing Delays
(normalized to $T_J = 70^\circ\text{C}$, $V_{CC} = 1.425\text{ V}$)

Array Voltage V_{CC} (V)	Junction Temperature ($^\circ\text{C}$)					
	-40°C	0°C	25°C	70°C	85°C	110°C
1.425	0.87	0.92	0.95	1.00	1.02	1.05
1.500	0.83	0.88	0.90	0.95	0.97	0.99
1.575	0.80	0.85	0.87	0.92	0.93	0.96

Calculating Power Dissipation

Quiescent Supply Current

Table 2-7 • Quiescent Supply Current Characteristics

	A3P015	A3P030	A3P060	A3P125	A3P250	A3P400	A3P600	A3P1000
Typical (25°C)	2 mA	2 mA	2 mA	2 mA	3 mA	3 mA	5 mA	8 mA
Max. (Commercial)	10 mA	10 mA	10 mA	10 mA	20 mA	20 mA	30 mA	50 mA
Max. (Industrial)	15 mA	15 mA	15 mA	15 mA	30 mA	30 mA	45 mA	75 mA

Notes:

- I_{DD} Includes V_{CC} , V_{PUMP} , V_{CC1} , and VMV currents. Values do not include I/O static contribution, which is shown in Table 2-11 and Table 2-12 on page 2-8.
- $-F$ speed grade devices may experience higher standby I_{DD} of up to five times the standard I_{DD} and higher I/O leakage.

Power per I/O Pin

Table 2-8 • Summary of I/O Input Buffer Power (Per Pin) – Default I/O Software Settings
Applicable to Advanced I/O Banks

	VMV (V)	Static Power P_{DC2} (mW) ¹	Dynamic Power P_{AC9} ($\mu\text{W}/\text{MHz}$) ²
Single-Ended			
3.3 V LVTTTL / 3.3 V LVCMOS	3.3	–	16.69
2.5 V LVCMOS	2.5	–	5.12
1.8 V LVCMOS	1.8	–	2.13
1.5 V LVCMOS (JESD8-11)	1.5	–	1.45
3.3 V PCI	3.3	–	18.11
3.3 V PCI-X	3.3	–	18.11
Differential			
LVDS	2.5	2.26	1.20
LVPECL	3.3	5.72	1.87

Notes:

- P_{DC2} is the static power (where applicable) measured on VMV.
- P_{AC9} is the total dynamic power measured on V_{CC} and VMV.

**Table 2-9 • Summary of I/O Input Buffer Power (Per Pin) – Default I/O Software Settings
Applicable to Standard Plus I/O Banks**

	VMV (V)	Static Power P_{DC2} (mW) ¹	Dynamic Power P_{AC9} (μ W/MHz) ²
Single-Ended			
3.3 V LVTTTL / 3.3 V LVCMOS	3.3	–	16.72
2.5 V LVCMOS	2.5	–	5.14
1.8 V LVCMOS	1.8	–	2.13
1.5 V LVCMOS (JESD8-11)	1.5	–	1.48
3.3 V PCI	3.3	–	18.13
3.3 V PCI-X	3.3	–	18.13

Notes:

1. P_{DC2} is the static power (where applicable) measured on VMV.
1. P_{AC9} is the total dynamic power measured on V_{CC} and VMV.

**Table 2-10 • Summary of I/O Input Buffer Power (Per Pin) – Default I/O Software Settings
Applicable to Standard I/O Banks**

	VMV (V)	Static Power P_{DC2} (mW) ¹	Dynamic Power P_{AC9} (μ W/MHz) ²
Single-Ended			
3.3 V LVTTTL / 3.3 V LVCMOS	3.3	–	16.79
2.5 V LVCMOS	2.5	–	5.19
1.8 V LVCMOS	1.8	–	2.18
1.5 V LVCMOS (JESD8-11)	1.5	–	1.52

Notes:

1. P_{DC2} is the static power (where applicable) measured on VMV.
1. P_{AC9} is the total dynamic power measured on V_{CC} and VMV.

**Table 2-11 • Summary of I/O Output Buffer Power (per pin) – Default I/O Software Settings¹
Applicable to Advanced I/O Banks**

	C_{LOAD} (pF)	V_{CCI} (V)	Static Power P_{DC3} (mW) ²	Dynamic Power P_{AC10} (μ W/MHz) ³
Single-Ended				
3.3 V LVTTTL / 3.3 V LVCMOS	35	3.3	–	468.67
2.5 V LVCMOS	35	2.5	–	267.48
1.8 V LVCMOS	35	1.8	–	149.46
1.5 V LVCMOS (JESD8-11)	35	1.5	–	103.12
3.3 V PCI	10	3.3	–	201.02
3.3 V PCI-X	10	3.3	–	201.02
Differential				
LVDS	–	2.5	7.74	88.92
LVPECL	–	3.3	19.54	166.52

Notes:

1. Dynamic power consumption is given for standard load and software default drive strength and output slew.
2. P_{DC3} is the static power (where applicable) measured on V_{CCI} .
3. P_{AC10} is the total dynamic power measured on V_{CC} and V_{CCI} .

**Table 2-12 • Summary of I/O Output Buffer Power (Per Pin) – Default I/O Software Settings¹
Applicable to Standard Plus I/O Banks**

	C_{LOAD} (pF)	V_{CCI} (V)	Static Power P_{DC3} (mW) ²	Dynamic Power P_{AC10} (μ W/MHz) ³
Single-Ended				
3.3 V LVTTTL / 3.3 V LVCMOS	35	3.3	–	452.67
2.5 V LVCMOS	35	2.5	–	258.32
1.8 V LVCMOS	35	1.8	–	133.59
1.5 V LVCMOS (JESD8-11)	35	1.5	–	92.84
3.3 V PCI	10	3.3	–	184.92
3.3 V PCI-X	10	3.3	–	184.92

Notes:

1. Dynamic power consumption is given for standard load and software default drive strength and output slew.
2. P_{DC3} is the static power (where applicable) measured on V_{MV} .
3. P_{AC10} is the total dynamic power measured on V_{CC} and V_{MV} .

**Table 2-13 • Summary of I/O Output Buffer Power (Per Pin) – Default I/O Software Settings¹
Applicable to Standard I/O Banks**

	C_{LOAD} (pF)	V_{CCI} (V)	Static Power P_{DC3} (mW) ²	Dynamic Power P_{AC10} (μ W/MHz) ³
Single-Ended				
3.3 V LVTTTL / 3.3 V LVCMOS	35	3.3	–	431.08
2.5 V LVCMOS	35	2.5	–	247.36
1.8 V LVCMOS	35	1.8	–	128.46
1.5 V LVCMOS (JESD8-11)	35	1.5	–	89.46

Notes:

1. Dynamic power consumption is given for standard load and software default drive strength and output slew.
2. P_{DC3} is the static power (where applicable) measured on V_{CCI} .
3. P_{AC10} is the total dynamic power measured on V_{CC} and V_{CCI} .

Power Consumption of Various Internal Resources

Table 2-14 • Different Components Contributing to Dynamic Power Consumption in ProASIC3 Devices

Parameter	Definition	Device Specific Dynamic Contributions ($\mu\text{W}/\text{MHz}$)							
		A3P1000	A3P600	A3P400	A3P250	A3P125	A3P060	A3P030	A3P015
P _{AC1}	Clock contribution of a Global Rib	14.50	12.80	12.80	11.00	11.00	9.30	9.30	9.30
P _{AC2}	Clock contribution of a Global Spine	2.48	1.85	1.35	1.58	0.81	0.81	0.41	0.41
P _{AC3}	Clock contribution of a VersaTile row	0.81							
P _{AC4}	Clock contribution of a VersaTile used as a sequential module	0.12							
P _{AC5}	First contribution of a VersaTile used as a sequential module	0.07							
P _{AC6}	Second contribution of a VersaTile used as a sequential module	0.29							
P _{AC7}	Contribution of a VersaTile used as a combinatorial Module	0.29							
P _{AC8}	Average contribution of a routing net	0.70							
P _{AC9}	Contribution of an I/O input pin (standard dependent)	See Table 2-8 on page 2-6 through Table 2-10 on page 2-7.							
P _{AC10}	Contribution of an I/O output pin (standard dependent)	See Table 2-11 on page 2-8 through Table 2-13 on page 2-9.							
P _{AC11}	Average contribution of a RAM block during a read operation	25.00							
P _{AC12}	Average contribution of a RAM block during a write operation	30.00							
P _{AC13}	Dynamic contribution for PLL	2.60							

Note: *For a different output load, drive strength, or slew rate, Actel recommends using the Actel Power spreadsheet calculator or SmartPower tool in Libero® Integrated Design Environment (IDE) software.

Table 2-15 • Different Components Contributing to the Static Power Consumption in ProASIC3 Devices

Parameter	Definition	Device Specific Static Power (mW)							
		A3P1000	A3P600	A3P400	A3P250	A3P125	A3P060	A3P030	A3P015
P _{DC1}	Array static power in Active mode	See Table 2-7 on page 2-6.							
P _{DC2}	I/O input pin static power (standard-dependent)	See Table 2-8 on page 2-6 through Table 2-10 on page 2-7.							
P _{DC3}	I/O output pin static power (standard-dependent)	See Table 2-11 on page 2-8 through Table 2-13 on page 2-9.							
P _{DC4}	Static PLL contribution	2.55 mW							
P _{DC5}	Bank quiescent power (V _{CCI} -dependent)	See Table 2-7 on page 2-6.							

Note: *For a different output load, drive strength, or slew rate, Actel recommends using the Actel

Power Calculation Methodology

This section describes a simplified method to estimate power consumption of an application. For more accurate and detailed power estimations, use the SmartPower tool in Actel Libero IDE software.

The power calculation methodology described below uses the following variables:

- The number of PLLs as well as the number and the frequency of each output clock generated
- The number of combinatorial and sequential cells used in the design
- The internal clock frequencies
- The number and the standard of I/O pins used in the design
- The number of RAM blocks used in the design
- Toggle rates of I/O pins as well as VersaTiles—guidelines are provided in [Table 2-16 on page 2-14](#).
- Enable rates of output buffers—guidelines are provided for typical applications in [Table 2-17 on page 2-14](#).
- Read rate and write rate to the memory—guidelines are provided for typical applications in [Table 2-17 on page 2-14](#). The calculation should be repeated for each clock domain defined in the design.

Methodology

Total Power Consumption— P_{TOTAL}

$$P_{TOTAL} = P_{STAT} + P_{DYN}$$

P_{STAT} is the total static power consumption.

P_{DYN} is the total dynamic power consumption.

Total Static Power Consumption— P_{STAT}

$$P_{STAT} = P_{DC1} + N_{INPUTS} * P_{DC2} + N_{OUTPUTS} * P_{DC3}$$

N_{INPUTS} is the number of I/O input buffers used in the design.

$N_{OUTPUTS}$ is the number of I/O output buffers used in the design.

Total Dynamic Power Consumption— P_{DYN}

$$P_{DYN} = P_{CLOCK} + P_{S-CELL} + P_{C-CELL} + P_{NET} + P_{INPUTS} + P_{OUTPUTS} + P_{MEMORY} + P_{PLL}$$

Global Clock Contribution— P_{CLOCK}

$$P_{CLOCK} = (P_{AC1} + N_{SPINE} * P_{AC2} + N_{ROW} * P_{AC3} + N_{S-CELL} * P_{AC4}) * F_{CLK}$$

N_{SPINE} is the number of global spines used in the user design—guidelines are provided in [Table 2-16 on page 2-14](#).

N_{ROW} is the number of VersaTile rows used in the design—guidelines are provided in [Table 2-16 on page 2-14](#).

F_{CLK} is the global clock signal frequency.

N_{S-CELL} is the number of VersaTiles used as sequential modules in the design.

P_{AC1} , P_{AC2} , P_{AC3} , and P_{AC4} are device-dependent.

Sequential Cells Contribution— P_{S-CELL}

$$P_{S-CELL} = N_{S-CELL} * (P_{AC5} + \alpha_1 / 2 * P_{AC6}) * F_{CLK}$$

N_{S-CELL} is the number of VersaTiles used as sequential modules in the design. When a multi-tile sequential cell is used, it should be accounted for as 1.

α_1 is the toggle rate of VersaTile outputs—guidelines are provided in [Table 2-16 on page 2-14](#).

F_{CLK} is the global clock signal frequency.

Combinatorial Cells Contribution— P_{C-CELL}

$$P_{C-CELL} = N_{C-CELL} * \alpha_1 / 2 * P_{AC7} * F_{CLK}$$

N_{C-CELL} is the number of VersaTiles used as combinatorial modules in the design.

α_1 is the toggle rate of VersaTile outputs—guidelines are provided in [Table 2-16 on page 2-14](#).

F_{CLK} is the global clock signal frequency.

Routing Net Contribution— P_{NET}

$$P_{NET} = (N_{S-CELL} + N_{C-CELL}) * \alpha_1 / 2 * P_{AC8} * F_{CLK}$$

N_{S-CELL} is the number of VersaTiles used as sequential modules in the design.

N_{C-CELL} is the number of VersaTiles used as combinatorial modules in the design.

α_1 is the toggle rate of VersaTile outputs—guidelines are provided in [Table 2-16 on page 2-14](#).

F_{CLK} is the global clock signal frequency.

I/O Input Buffer Contribution— P_{INPUTS}

$$P_{INPUTS} = N_{INPUTS} * \alpha_2 / 2 * P_{AC9} * F_{CLK}$$

N_{INPUTS} is the number of I/O input buffers used in the design.

α_2 is the I/O buffer toggle rate—guidelines are provided in [Table 2-16 on page 2-14](#).

F_{CLK} is the global clock signal frequency.

I/O Output Buffer Contribution— $P_{OUTPUTS}$

$$P_{OUTPUTS} = N_{OUTPUTS} * \alpha_2 / 2 * \beta_1 * P_{AC10} * F_{CLK}$$

$N_{OUTPUTS}$ is the number of I/O output buffers used in the design.

α_2 is the I/O buffer toggle rate—guidelines are provided in [Table 2-16 on page 2-14](#).

β_1 is the I/O buffer enable rate—guidelines are provided in [Table 2-17 on page 2-14](#).

F_{CLK} is the global clock signal frequency.

RAM Contribution— P_{MEMORY}

$$P_{MEMORY} = P_{AC11} * N_{BLOCKS} * F_{READ-CLOCK} * \beta_2 + P_{AC12} * N_{BLOCK} * F_{WRITE-CLOCK} * \beta_3$$

N_{BLOCKS} is the number of RAM blocks used in the design.

$F_{READ-CLOCK}$ is the memory read clock frequency.

β_2 is the RAM enable rate for read operations.

$F_{WRITE-CLOCK}$ is the memory write clock frequency.

β_3 is the RAM enable rate for write operations—guidelines are provided in [Table 2-17 on page 2-14](#).

PLL Contribution— P_{PLL}

$$P_{PLL} = P_{DC4} + P_{AC13} * F_{CLKOUT}$$

F_{CLKOUT} is the output clock frequency.¹

1. The PLL dynamic contribution depends on the input clock frequency, the number of output clock signals generated by the PLL, and the frequency of each output clock. If a PLL is used to generate more than one output clock, include each output clock in the formula by adding its corresponding contribution ($P_{AC14} * F_{CLKOUT}$ product) to the total PLL contribution.

Guidelines

Toggle Rate Definition

A toggle rate defines the frequency of a net or logic element relative to a clock. It is a percentage. If the toggle rate of a net is 100%, this means that this net switches at half the clock frequency. Below are some examples:

- The average toggle rate of a shift register is 100% because all flip-flop outputs toggle at half of the clock frequency.
- The average toggle rate of an 8-bit counter is 25%:
 - Bit 0 (LSB) = 100%
 - Bit 1 = 50%
 - Bit 2 = 25%
 - ...
 - Bit 7 (MSB) = 0.78125%
 - Average toggle rate = $(100\% + 50\% + 25\% + 12.5\% + \dots + 0.78125\%) / 8$

Enable Rate Definition

Output enable rate is the average percentage of time during which tristate outputs are enabled. When nontristate output buffers are used, the enable rate should be 100%.

Table 2-16 • Toggle Rate Guidelines Recommended for Power Calculation

Component	Definition	Guideline
α_1	Toggle rate of VersaTile outputs	10%
α_2	I/O buffer toggle rate	10%

Table 2-17 • Enable Rate Guidelines Recommended for Power Calculation

Component	Definition	Guideline
β_1	I/O output buffer enable rate	100%
β_2	RAM enable rate for read operations	12.5%
β_3	RAM enable rate for write operations	12.5%

User I/O Characteristics

Timing Model

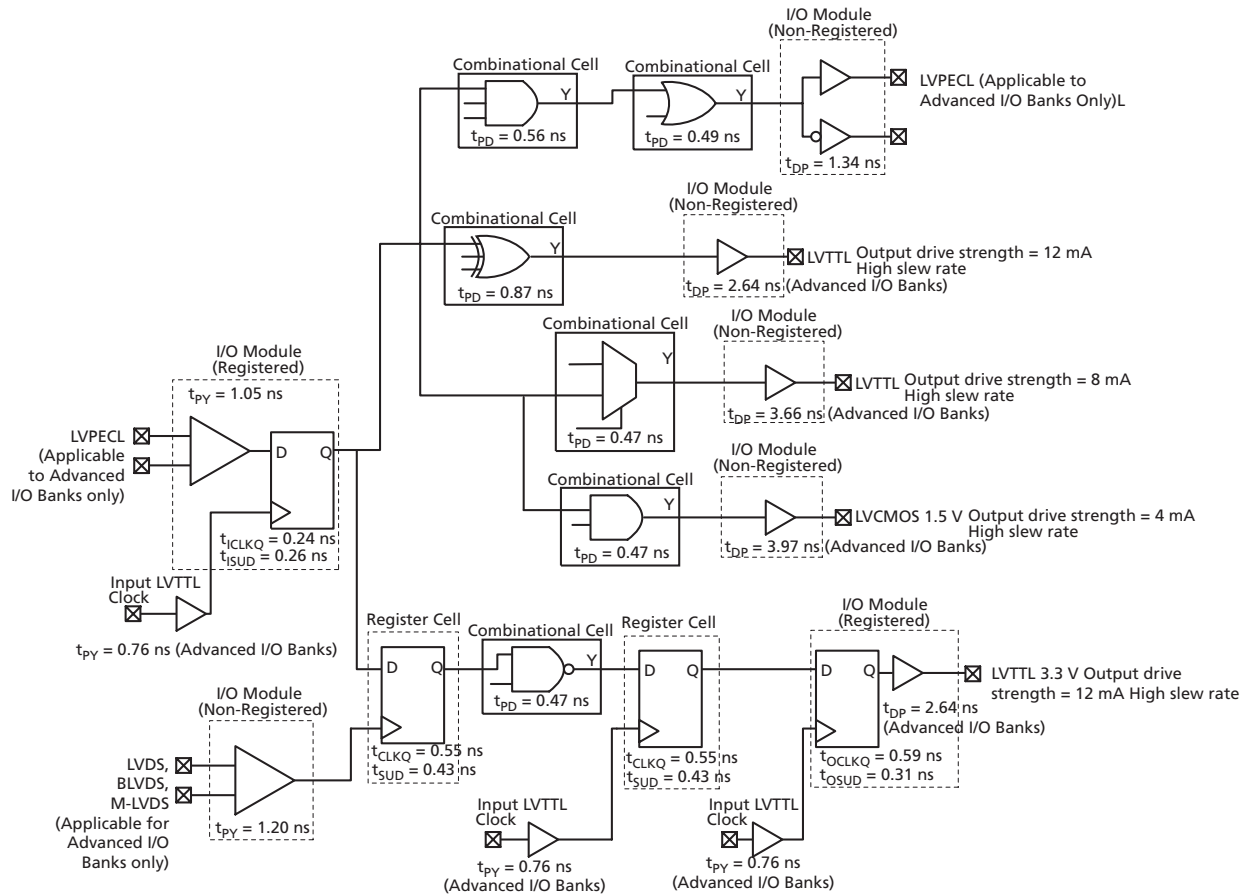

Figure 2-2 • Timing Model

Operating Conditions: -2 Speed, Commercial Temperature Range ($T_J = 70^\circ\text{C}$), Worst Case
 $V_{CC} = 1.425$ V

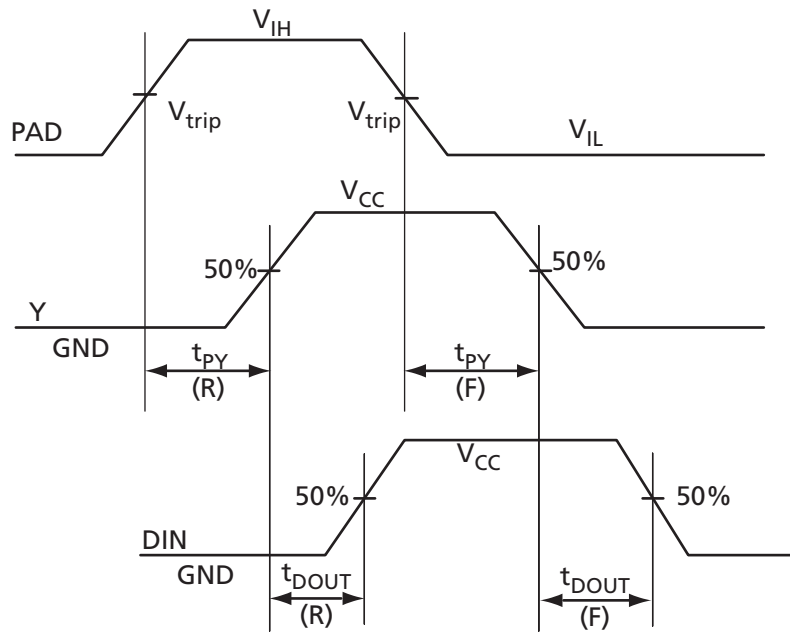
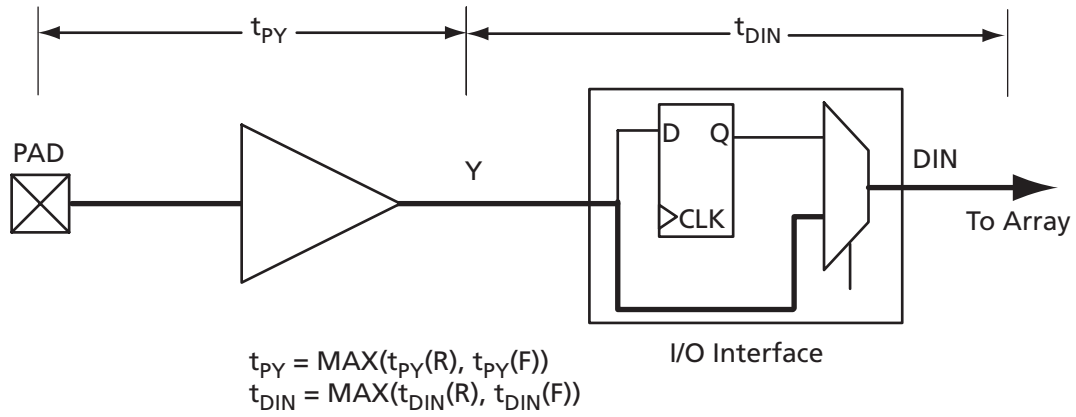

Figure 2-3 • Input Buffer Timing Model and Delays (example)

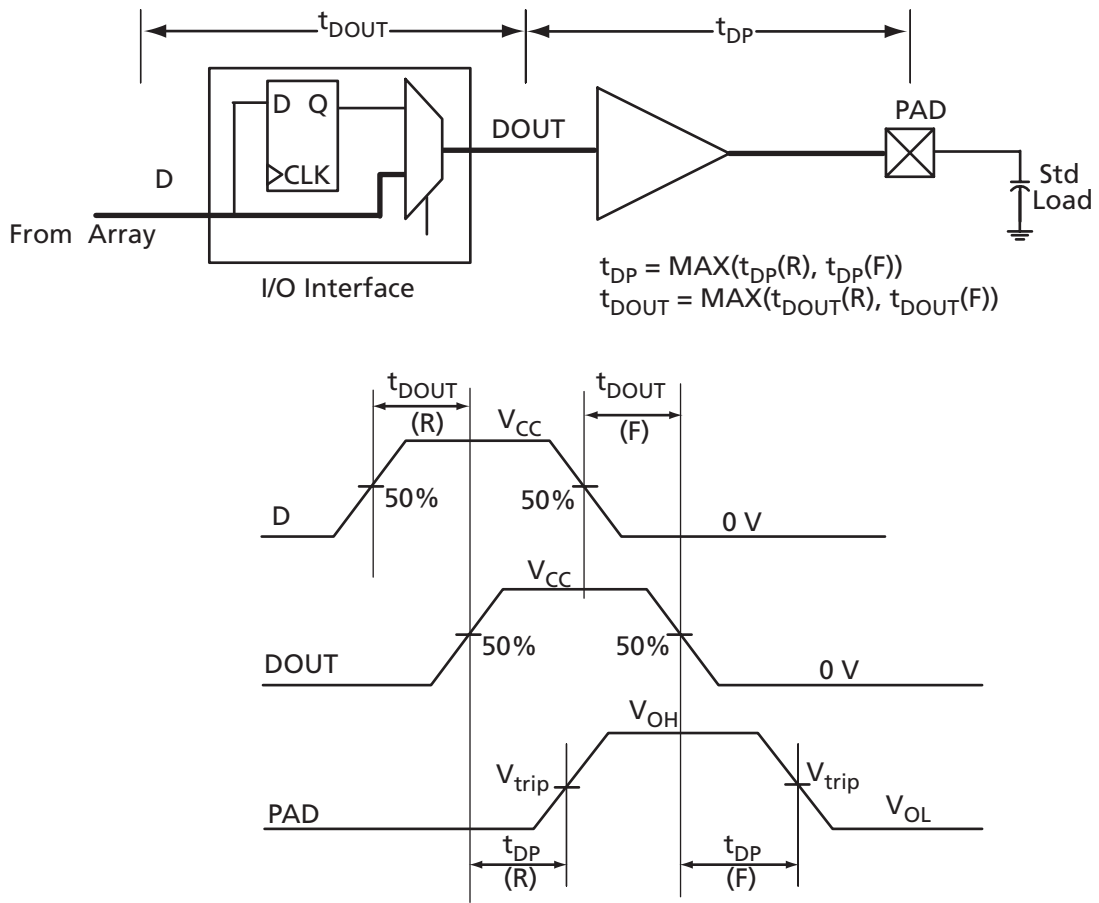

Figure 2-4 • Output Buffer Model and Delays (example)

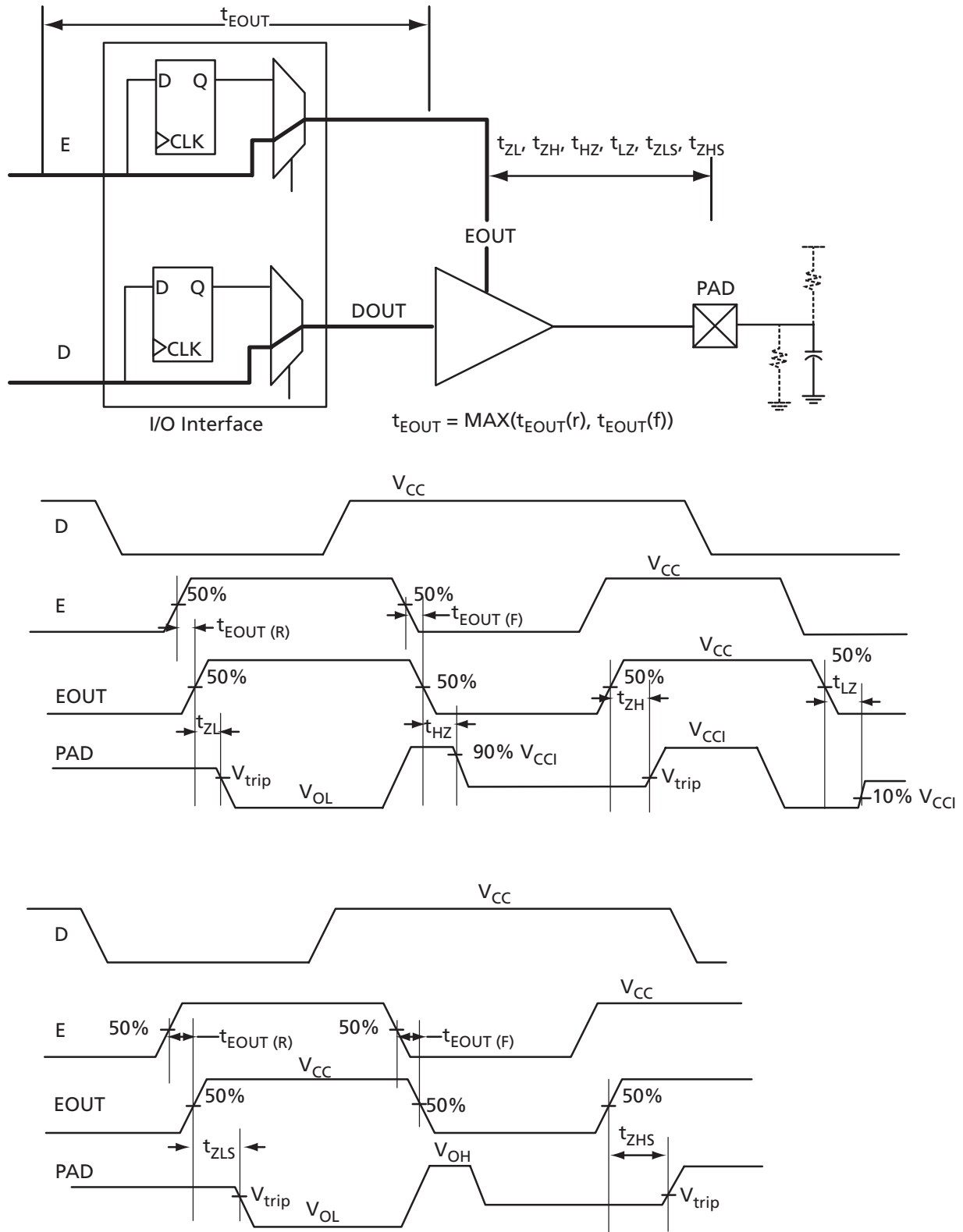

Figure 2-5 • Tristate Output Buffer Timing Model and Delays (example)

Overview of I/O Performance

Summary of I/O DC Input and Output Levels – Default I/O Software Settings

Table 2-18 • Summary of Maximum and Minimum DC Input and Output Levels Applicable to Commercial and Industrial Conditions—Software Default Settings
Applicable to Advanced I/O Banks

I/O Standard	Drive Strength	Slew Rate	V _{IL}		V _{IH}		V _{OL}	V _{OH}	I _{OL}	I _{OH}
			Min, V	Max, V	Min, V	Max, V	Max, V	Min, V	mA	mA
3.3 V LVTTTL / 3.3 V LVCMOS	12 mA	High	-0.3	0.8	2	3.6	0.4	2.4	12	12
2.5 V LVCMOS	12 mA	High	-0.3	0.7	1.7	3.6	0.7	1.7	12	12
1.8 V LVCMOS	12 mA	High	-0.3	0.35 * V _{CC1}	0.65 * V _{CC1}	3.6	0.45	V _{CC1} - 0.45	12	12
1.5 V LVCMOS	12 mA	High	-0.3	0.30 * V _{CC1}	0.7 * V _{CC1}	3.6	0.25 * V _{CC1}	0.75 * V _{CC1}	12	12
3.3 V PCI	Per PCI specifications									
3.3 V PCI-X	Per PCI-X specifications									

Note: Currents are measured at 85°C junction temperature.

Table 2-19 • Summary of Maximum and Minimum DC Input and Output Levels Applicable to Commercial and Industrial Conditions—Software Default Settings
Applicable to Standard Plus I/O Banks

I/O Standard	Drive Strength	Slew Rate	V _{IL}		V _{IH}		V _{OL}	V _{OH}	I _{OL}	I _{OH}
			Min, V	Max, V	Min, V	Max, V	Max, V	Min, V	mA	mA
3.3 V LVTTTL / 3.3 V LVCMOS	12 mA	High	-0.3	0.8	2	3.6	0.4	2.4	12	12
2.5 V LVCMOS	12 mA	High	-0.3	0.7	1.7	3.6	0.7	1.7	12	12
1.8 V LVCMOS	8 mA	High	-0.3	0.35 * V _{CC1}	0.65 * V _{CC1}	3.6	0.45	V _{CC1} - 0.45	8	8
1.5 V LVCMOS	4 mA	High	-0.3	0.30 * V _{CC1}	0.7 * V _{CC1}	3.6	0.25 * V _{CC1}	0.75 * V _{CC1}	4	4
3.3 V PCI	Per PCI specifications									
3.3 V PCI-X	Per PCI-X specifications									

Note: Currents are measured at 85°C junction temperature.

Table 2-20 • Summary of Maximum and Minimum DC Input and Output Levels Applicable to Commercial and Industrial Conditions—Software Default Settings
Applicable to Standard I/O Banks

I/O Standard	Drive Strength	Slew Rate	V _{IL}		V _{IH}		V _{OL}	V _{OH}	I _{OL}	I _{OH}
			Min, V	Max, V	Min, V	Max, V	Max, V	Min, V	mA	mA
3.3 V LVTTTL / 3.3 V LVCMOS	8 mA	High	-0.3	0.8	2	3.6	0.4	2.4	8	8
2.5 V LVCMOS	8 mA	High	-0.3	0.7	1.7	3.6	0.7	1.7	8	8
1.8 V LVCMOS	4 mA	High	-0.3	0.35 * V _{CC1}	0.65 * V _{CC1}	3.6	0.45	V _{CC1} - 0.45	4	4
1.5 V LVCMOS	2 mA	High	-0.3	0.30 * V _{CC1}	0.7 * V _{CC1}	3.6	0.25 * V _{CC1}	0.75 * V _{CC1}	2	2

Note: Currents are measured at 85°C junction temperature.

**Table 2-21 • Summary of Maximum and Minimum DC Input Levels
Applicable to Commercial and Industrial Conditions**

DC I/O Standards	Commercial ¹		Industrial ²	
	I _{IL}	I _{IH}	I _{IL}	I _{IH}
	μA	μA	μA	μA
3.3 V LVTTTL / 3.3 V LVCMOS	10	10	15	15
2.5 V LVCMOS	10	10	15	15
1.8 V LVCMOS	10	10	15	15
1.5 V LVCMOS	10	10	15	15
3.3 V PCI	10	10	15	15
3.3 V PCI-X	10	10	15	15

Notes:

1. Commercial range ($0^{\circ}\text{C} < T_A < 70^{\circ}\text{C}$)
2. Industrial range ($-40^{\circ}\text{C} < T_A < 85^{\circ}\text{C}$)

Summary of I/O Timing Characteristics – Default I/O Software Settings

Table 2-22 • Summary of AC Measuring Points

Standard	Measuring Trip Point (V _{trip})
3.3 V LVTTTL / 3.3 V LVCMOS	1.4 V
2.5 V LVCMOS	1.2 V
1.8 V LVCMOS	0.90 V
1.5 V LVCMOS	0.75 V
3.3 V PCI	0.285 * V _{CC1} (RR)
	0.615 * V _{CC1} (FF)
3.3 V PCI-X	0.285 * V _{CC1} (RR)
	0.615 * V _{CC1} (FF)

Table 2-23 • I/O AC Parameter Definitions

Parameter	Parameter Definition
t _{DP}	Data to Pad delay through the Output Buffer
t _{PY}	Pad to Data delay through the Input Buffer
t _{DOUT}	Data to Output Buffer delay through the I/O interface
t _{EOUT}	Enable to Output Buffer Tristate Control delay through the I/O interface
t _{DIN}	Input Buffer to Data delay through the I/O interface
t _{HZ}	Enable to Pad delay through the Output Buffer—HIGH to Z
t _{ZH}	Enable to Pad delay through the Output Buffer—Z to HIGH
t _{LZ}	Enable to Pad delay through the Output Buffer—LOW to Z
t _{ZL}	Enable to Pad delay through the Output Buffer—Z to LOW
t _{ZHS}	Enable to Pad delay through the Output Buffer with delayed enable—Z to HIGH
t _{ZLS}	Enable to Pad delay through the Output Buffer with delayed enable—Z to LOW



Table 2-24 • Summary of I/O Timing Characteristics—Software Default Settings
 –2 Speed Grade, Commercial-Case Conditions: $T_J = 70^\circ\text{C}$, Worst Case $V_{CC} = 1.425\text{ V}$,
 Worst Case $V_{CCI} = 3.0\text{ V}$
 Advanced I/O Banks

I/O Standard	Drive Strength (mA)	Slew Rate	Capacitive Load (pF)	External Resistor (Ω)	t_{DOUT} (ns)	t_{DP} (ns)	t_{DIN} (ns)	t_{PY} (ns)	t_{EOUT} (ns)	t_{ZL} (ns)	t_{ZH} (ns)	t_{LZ} (ns)	t_{HZ} (ns)	t_{ZLS} (ns)	t_{ZHS} (ns)	Units
3.3 V LVTTTL / 3.3 V LVCMOS	12	High	35	–	0.49	2.64	0.03	0.76	0.32	2.69	2.11	2.40	2.68	4.36	3.78	ns
2.5 V LVCMOS	12	High	35	–	0.49	2.66	0.03	0.98	0.32	2.71	2.56	2.47	2.57	4.38	4.23	ns
1.8 V LVCMOS	12	High	35	–	0.49	2.64	0.03	0.91	0.32	2.69	2.27	2.76	3.05	4.36	3.94	ns
1.5 V LVCMOS	12	High	35	–	0.49	3.05	0.03	1.07	0.32	3.10	2.67	2.95	3.14	4.77	4.34	ns
3.3 V PCI	Per PCI spec.	High	10	25 ²	0.49	2.00	0.03	0.65	0.32	2.04	1.46	2.40	2.68	3.71	3.13	ns
3.3 V PCI-X	Per PCI-X spec.	High	10	25 ²	0.49	2.00	0.03	0.65	0.32	2.04	1.46	2.40	2.68	3.71	3.13	ns
LVDS	24	High	–	–	0.49	1.37	0.03	1.20	–	–	–	–	–	–	–	n
LVPECL	24	High	–	–	0.49	1.34	0.03	1.05	–	–	–	–	–	–	–	ns

Notes:

1. For specific junction temperature and voltage supply levels, refer to [Table 2-6 on page 2-6](#) for derating values.
2. Resistance is used to measure I/O propagation delays as defined in PCI specifications. See [Figure 2-10 on page 2-56](#) for connectivity. This resistor is not required during normal operation.

Table 2-25 • Summary of I/O Timing Characteristics—Software Default Settings
 –2 Speed Grade, Commercial-Case Conditions: $T_j = 70^\circ\text{C}$, Worst Case $V_{CC} = 1.425\text{ V}$, Worst Case $V_{CCI} = 3.0\text{ V}$
 Standard Plus I/O Banks

I/O Standard	Drive Strength (mA)	Slew Rate	Capacitive Load (pF)	External Resistor	t_{DOUT} (ns)	t_{DP} (ns)	t_{DIN} (ns)	t_{PY} (ns)	t_{EOUT} (ns)	t_{ZL} (ns)	t_{ZH} (ns)	t_{LZ} (ns)	t_{HZ} (ns)	t_{ZLS} (ns)	t_{ZHS} (ns)	Units
3.3 V LVTTTL / 3.3 V LVCMOS	12 mA	High	35 pF	–	0.49	2.36	0.03	0.75	0.32	2.40	1.93	2.08	2.41	4.07	3.60	ns
2.5 V LVCMOS	12 mA	High	35 pF	–	0.49	2.39	0.03	0.97	0.32	2.44	2.35	2.11	2.32	4.11	4.02	ns
1.8 V LVCMOS	8 mA	High	35 pF	–	0.49	3.03	0.03	0.90	0.32	2.87	3.03	2.19	2.32	4.54	4.70	ns
1.5 V LVCMOS	4 mA	High	35 pF	–	0.49	3.61	0.03	1.06	0.32	3.35	3.61	2.26	2.34	5.02	5.28	ns
3.3 V PCI	Per PCI spec.	High	10 pF	25 ²	0.49	1.72	0.03	0.64	0.32	1.76	1.27	2.08	2.41	3.42	2.94	ns
3.3 V PCI-X	Per PCI-X spec.	High	10 pF	25 ²	0.49	1.72	0.03	0.64	0.32	1.76	1.27	2.08	2.41	3.42	2.94	ns

Notes:

1. For specific junction temperature and voltage supply levels, refer to [Table 2-6 on page 2-6](#) for derating values.
2. Resistance is used to measure I/O propagation delays as defined in PCI specifications. See [Figure 2-10 on page 2-56](#) for connectivity. This resistor is not required during normal operation.

Table 2-26 • Summary of I/O Timing Characteristics—Software Default Settings
 –2 Speed Grade, Commercial-Case Conditions: $T_j = 70^\circ\text{C}$, Worst Case $V_{CC} = 1.425\text{ V}$, Worst Case $V_{CCI} = 3.0\text{ V}$
 Standard I/O Banks

I/O Standard	Drive Strength (mA)	Slew Rate	Capacitive Load (pF)	External Resistor	t_{DOUT} (ns)	t_{DP} (ns)	t_{DIN} (ns)	t_{PY} (ns)	t_{EOUT} (ns)	t_{ZL} (ns)	t_{ZH} (ns)	t_{LZ} (ns)	t_{HZ} (ns)	Units
3.3 V LVTTTL / 3.3 V LVCMOS	8 mA	High	35 pF	–	0.49	3.29	0.03	0.75	0.32	3.36	2.80	1.79	2.01	ns
2.5 V LVCMOS	8 mA	High	35 pF	–	0.49	3.56	0.03	0.96	0.32	3.40	3.56	1.78	1.91	ns
1.8 V LVCMOS	4 mA	High	35 pF	–	0.49	4.74	0.03	0.90	0.32	4.02	4.74	1.80	1.85	ns
1.5 V LVCMOS	2 mA	High	35 pF	–	0.49	5.71	0.03	1.06	0.32	4.71	5.71	1.83	1.83	ns

Notes:

1. For specific junction temperature and voltage supply levels, refer to [Table 2-6 on page 2-6](#) for derating values.
2. Resistance is used to measure I/O propagation delays as defined in PCI specifications. See [Figure 2-10 on page 2-56](#) for connectivity. This resistor is not required during normal operation.

Detailed I/O DC Characteristics

Table 2-27 • Input Capacitance

Symbol	Definition	Conditions	Min.	Max.	Units
C_{IN}	Input capacitance	$V_{IN} = 0, f = 1.0 \text{ MHz}$		8	pF
C_{INCLK}	Input capacitance on the clock pin	$V_{IN} = 0, f = 1.0 \text{ MHz}$		8	pF

**Table 2-28 • I/O Output Buffer Maximum Resistances¹
Applicable to Advanced I/O Banks**

Standard	Drive Strength	$R_{PULL-DOWN}$ (Ω) ²	$R_{PULL-UP}$ (Ω) ³
3.3 V LVTTTL / 3.3 V LVCMOS	2 mA	100	300
	4 mA	100	300
	6 mA	50	150
	8 mA	50	150
	12 mA	25	75
	16 mA	17	50
	24 mA	11	33
2.5 V LVCMOS	2 mA	100	200
	4 mA	100	200
	6 mA	50	100
	8 mA	50	100
	12 mA	25	50
	16 mA	20	40
	24 mA	11	22
1.8 V LVCMOS	2 mA	200	225
	4 mA	100	112
	6 mA	50	56
	8 mA	50	56
	12 mA	20	22
	16 mA	20	22
1.5 V LVCMOS	2 mA	200	224
	4 mA	100	112
	6 mA	67	75
	8 mA	33	37
	12 mA	33	37
3.3 V PCI/PCI-X	Per PCI/PCI-X specification	25	75

Notes:

1. These maximum values are provided for informational reasons only. Minimum output buffer resistance values depend on V_{CC} , drive strength selection, temperature, and process. For board design considerations and detailed output buffer resistances, use the corresponding IBIS models located on the Actel website at <http://www.actel.com/download/libis/default.aspx>.
2. $R_{(PULL-DOWN-MAX)} = (V_{OLspec}) / I_{OLspec}$
3. $R_{(PULL-UP-MAX)} = (V_{CCImax} - V_{OHspec}) / I_{OHspec}$

Table 2-29 • I/O Output Buffer Maximum Resistances¹
Applicable to Standard Plus I/O Banks

Standard	Drive Strength	R _{PULL-DOWN} (Ω) ²	R _{PULL-UP} (Ω) ³
3.3 V LVTTTL / 3.3 V LVCMOS	2 mA	100	300
	4 mA	100	300
	6 mA	50	150
	8 mA	50	150
	12 mA	25	75
	16 mA	25	75
2.5 V LVCMOS	2 mA	100	200
	4 mA	100	200
	6 mA	50	100
	8 mA	50	100
	12 mA	25	50
1.8 V LVCMOS	2 mA	200	225
	4 mA	100	112
	6 mA	50	56
	8 mA	50	56
1.5 V LVCMOS	2 mA	200	224
	4 mA	100	112
3.3 V PCI/PCI-X	Per PCI/PCI-X specification	25	75

Notes:

1. These maximum values are provided for informational reasons only. Minimum output buffer resistance values depend on V_{CC} , drive strength selection, temperature, and process. For board design considerations and detailed output buffer resistances, use the corresponding IBIS models located on the Actel website at <http://www.actel.com/download/libis/default.aspx>.
2. $R_{(PULL-DOWN-MAX)} = (V_{OLspec}) / I_{OLspec}$
3. $R_{(PULL-UP-MAX)} = (V_{CCImax} - V_{OHspec}) / I_{OHspec}$

Table 2-30 • I/O Output Buffer Maximum Resistances¹
 Applicable to Standard I/O Banks

Standard	Drive Strength	R _{PULL-DOWN} (Ω) ²	R _{PULL-UP} (Ω) ³
3.3 V LVTTTL / 3.3 V LVCMOS	2 mA	100	300
	4 mA	100	300
	6 mA	50	150
	8 mA	50	150
2.5 V LVCMOS	2 mA	100	200
	4 mA	100	200
	6 mA	50	100
	8 mA	50	100
1.8 V LVCMOS	2 mA	200	225
	4 mA	100	112
1.5 V LVCMOS	2 mA	200	224

Notes:

1. These maximum values are provided for informational reasons only. Minimum output buffer resistance values depend on V_{CC} , drive strength selection, temperature, and process. For board design considerations and detailed output buffer resistances, use the corresponding IBIS models located on the Actel website at <http://www.actel.com/download/libis/default.aspx>.
2. $R_{(PULL-DOWN-MAX)} = (V_{OLspec}) / I_{OLspec}$
3. $R_{(PULL-UP-MAX)} = (V_{CCImax} - V_{OHspec}) / I_{OHspec}$

Table 2-31 • I/O Weak Pull-Up/Pull-Down Resistances
 Minimum and Maximum Weak Pull-Up/Pull-Down Resistance Values

V _{CC}	R _(WEAK PULL-UP) ¹ (Ω)		R _(WEAK PULL-DOWN) ² (Ω)	
	Min.	Max.	Min.	Max.
3.3 V	10 k	45 k	10 k	45 k
2.5 V	11 k	55 k	12 k	74 k
1.8 V	18 k	70 k	17 k	110 k
1.5 V	19 k	90 k	19 k	140 k

Notes:

1. $R_{(WEAK PULL-UP-MAX)} = (V_{OLspec}) / I_{(WEAK PULL-UP-MIN)}$
2. $R_{(WEAK PULL-UP-MAX)} = (V_{CCImax} - V_{OHspec}) / I_{(WEAK PULL-UP-MIN)}$

**Table 2-32 • I/O Short Currents I_{OSH}/I_{OSL}
Applicable to Advanced I/O Banks**

	Drive Strength	I_{OSL} (mA)*	I_{OSH} (mA)*
3.3 V LVTTTL / 3.3 V LVCMOS	2 mA	27	25
	4 mA	27	25
	6 mA	54	51
	8 mA	54	51
	12 mA	109	103
	16 mA	127	132
	24 mA	181	268
3.3 V LVCMOS	2 mA	27	25
	4 mA	27	25
	6 mA	54	51
	8 mA	54	51
	12 mA	109	103
	16 mA	127	132
	24 mA	181	268
2.5 V LVCMOS	2 mA	18	16
	4 mA	18	16
	6 mA	37	32
	8 mA	37	32
	12 mA	74	65
	16 mA	87	83
	24 mA	124	169
1.8 V LVCMOS	2 mA	11	9
	4 mA	22	17
	6 mA	44	35
	8 mA	51	45
	12 mA	74	91
	16 mA	74	91
1.5 V LVCMOS	2 mA	16	13
	4 mA	33	25
	6 mA	39	32
	8 mA	55	66
	12 mA	55	66
3.3 V PCI/PCI-X	Per PCI/PCI-X specification	109	103

* $T_J = 100^\circ\text{C}$

**Table 2-33 • I/O Short Currents I_{OSH}/I_{OSL}
Applicable to Standard Plus I/O Banks**

	Drive Strength	I_{OSL} (mA)*	I_{OSH} (mA)*
3.3 V LVTTTL / 3.3 V LVCMOS	2 mA	27	25
	4 mA	27	25
	6 mA	54	51
	8 mA	54	51
	12 mA	109	103
	16 mA	109	103
2.5 V LVCMOS	2 mA	18	16
	4 mA	18	16
	6 mA	37	32
	8 mA	37	32
	12 mA	74	65
1.8 V LVCMOS	2 mA	11	9
	4 mA	22	17
	6 mA	44	35
	8 mA	44	35
1.5 V LVCMOS	2 mA	16	13
	4 mA	33	25
3.3 V PCI/PCI-X	Per PCI/PCI-X specification	109	103

* $T_J = 100^\circ\text{C}$

**Table 2-34 • I/O Short Currents I_{OSH}/I_{OSL}
Applicable to Standard I/O Banks**

	Drive Strength	I_{OSL} (mA)*	I_{OSH} (mA)*
3.3 V LVTTTL / 3.3 V LVCMOS	2 mA	27	25
	4 mA	27	25
	6 mA	54	51
	8 mA	54	51
2.5 V LVCMOS	2 mA	18	16
	4 mA	18	16
	6 mA	37	32
	8 mA	37	32
1.8 V LVCMOS	2 mA	11	9
	4 mA	22	17
1.5 V LVCMOS	2 mA	16	13

* $T_J = 100^\circ\text{C}$

The length of time an I/O can withstand I_{OSH}/I_{OSL} events depends on the junction temperature. The reliability data below is based on a 3.3 V, 12 mA I/O setting, which is the worst case for this type of analysis.

For example, at 110°C, the short current condition would have to be sustained for more than three months to cause a reliability concern. The I/O design does not contain any short circuit protection, but such protection would only be needed in extremely prolonged stress conditions.

Table 2-35 • Duration of Short Circuit Event before Failure

Temperature	Time before Failure
-40°C	> 20 years
0°C	> 20 years
25°C	> 20 years
70°C	5 years
85°C	2 years
100°C	6 months
110°C	3 months

Table 2-36 • I/O Input Rise Time, Fall Time, and Related I/O Reliability

Input Buffer	Input Rise/Fall Time (min.)	Input Rise/Fall Time (max.)	Reliability
LVTTL/LVCMOS	No requirement	10 ns *	20 years (110°C)
LVDS/B-LVDS/ M-LVDS/LVPECL	No requirement	10 ns *	10 years (100°C)

* The maximum input rise/fall time is related to the noise induced into the input buffer trace. If the noise is low, then the rise time and fall time of input buffers can be increased beyond the maximum value. The longer the rise/fall times, the more susceptible the input signal is to the board noise. Actel recommends signal integrity evaluation/characterization of the system to ensure that there is no excessive noise coupling into input signals.

Single-Ended I/O Characteristics

3.3 V LVTTTL / 3.3 V LVCMOS

Low-Voltage Transistor–Transistor Logic (LVTTTL) is a general-purpose standard (EIA/JESD) for 3.3 V applications. It uses an LVTTTL input buffer and push-pull output buffer.

Table 2-37 • Minimum and Maximum DC Input and Output Levels
Applicable to Advanced I/O Banks

3.3 V LVTTTL / 3.3 V LVCMOS	V _{IL}		V _{IH}		V _{OL}	V _{OH}	I _{OL}	I _{OH}	I _{OSL}	I _{OSH}	I _{IL}	I _{IH}
	Min., V	Max., V	Min., V	Max., V	Max., V	Min., V	mA	mA	Max., mA ¹	Max., mA ¹	μA ²	μA ²
2 mA	-0.3	0.8	2	3.6	0.4	2.4	2	2	27	25	10	10
4 mA	-0.3	0.8	2	3.6	0.4	2.4	4	4	27	25	10	10
6 mA	-0.3	0.8	2	3.6	0.4	2.4	6	6	54	51	10	10
8 mA	-0.3	0.8	2	3.6	0.4	2.4	8	8	54	51	10	10
12 mA	-0.3	0.8	2	3.6	0.4	2.4	12	12	109	103	10	10
16 mA	-0.3	0.8	2	3.6	0.4	2.4	16	16	127	132	10	10
24 mA	-0.3	0.8	2	3.6	0.4	2.4	24	24	181	268	10	10

Notes:

1. Currents are measured at high temperature (100°C junction temperature) and maximum voltage.
2. Currents are measured at 85°C junction temperature.
3. Software default selection highlighted in gray.

Table 2-38 • Minimum and Maximum DC Input and Output Levels
Applicable to Standard Plus I/O Banks

3.3 V LVTTTL / 3.3 V LVCMOS	V _{IL}		V _{IH}		V _{OL}	V _{OH}	I _{OL}	I _{OH}	I _{OSL}	I _{OSH}	I _{IL}	I _{IH}
	Min., V	Max., V	Min., V	Max., V	Max., V	Min., V	mA	mA	Max., mA ¹	Max., mA ¹	μA ²	μA ²
2 mA	-0.3	0.8	2	3.6	0.4	2.4	2	2	27	25	10	10
4 mA	-0.3	0.8	2	3.6	0.4	2.4	4	4	27	25	10	10
6 mA	-0.3	0.8	2	3.6	0.4	2.4	6	6	54	51	10	10
8 mA	-0.3	0.8	2	3.6	0.4	2.4	8	8	54	51	10	10
12 mA	-0.3	0.8	2	3.6	0.4	2.4	12	12	109	103	10	10
16 mA	-0.3	0.8	2	3.6	0.4	2.4	16	16	109	103	10	10

Notes:

1. Currents are measured at high temperature (100°C junction temperature) and maximum voltage.
2. Currents are measured at 85°C junction temperature.
3. Software default selection highlighted in gray.

Table 2-39 • Minimum and Maximum DC Input and Output Levels
Applicable to Standard I/O Banks

3.3 V LVTTTL / 3.3 V LVCMOS	V_{IL}		V_{IH}		V_{OL}	V_{OH}	I_{OL}	I_{OH}	I_{OSL}	I_{OSH}	I_{IL}	I_{IH}
	Min., V	Max., V	Min., V	Max., V	Max., V	Min., V	mA	mA	Max., mA ¹	Max., mA ¹	μA^2	μA^2
2 mA	-0.3	0.8	2	3.6	0.4	2.4	2	2	25	27	10	10
4 mA	-0.3	0.8	2	3.6	0.4	2.4	4	4	25	27	10	10
6 mA	-0.3	0.8	2	3.6	0.4	2.4	6	6	51	54	10	10
8 mA	-0.3	0.8	2	3.6	0.4	2.4	8	8	51	54	10	10

Notes:

1. Currents are measured at high temperature (100°C junction temperature) and maximum voltage.
2. Currents are measured at 85°C junction temperature.
3. Software default selection highlighted in gray.

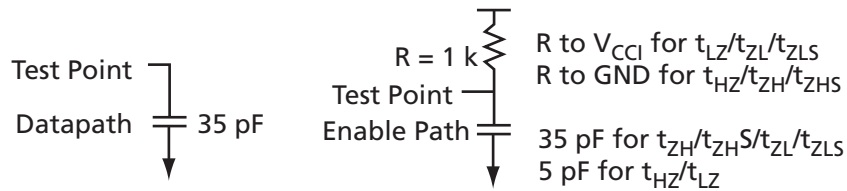

Figure 2-6 • AC Loading

Table 2-40 • AC Waveforms, Measuring Points, and Capacitive Loads

Input LOW (V)	Input HIGH (V)	Measuring Point* (V)	C_{LOAD} (pF)
0	3.3	1.4	35

* Measuring point = V_{trip} . See Table 2-22 on page 2-20 for a complete table of trip points.

Timing Characteristics

Table 2-41 • 3.3 V LVTTTL / 3.3 V LVCMOS High Slew
 Commercial-Case Conditions: $T_J = 70^\circ\text{C}$, Worst-Case $V_{CC} = 1.425\text{ V}$, Worst-Case $V_{CCI} = 3.0\text{ V}$
 Applicable to Advanced I/O Banks

Drive Strength	Speed Grade	t_{DOUT}	t_{DP}	t_{DIN}	t_{PY}	t_{EOUT}	t_{ZL}	t_{ZH}	t_{LZ}	t_{HZ}	t_{ZLS}	t_{ZHS}	Units
4 mA	-F	0.79	9.20	0.05	1.22	0.51	9.37	7.91	3.18	3.14	12.05	10.60	ns
	Std.	0.66	7.66	0.04	1.02	0.43	7.80	6.59	2.65	2.61	10.03	8.82	ns
	-1	0.56	6.51	0.04	0.86	0.36	6.63	5.60	2.25	2.22	8.54	7.51	ns
	-2	0.49	5.72	0.03	0.76	0.32	5.82	4.92	1.98	1.95	7.49	6.59	ns
6 mA	-F	0.79	5.89	0.05	1.22	0.51	6.00	4.89	3.59	3.85	8.69	7.57	ns
	Std.	0.66	4.91	0.04	1.02	0.43	5.00	4.07	2.99	3.20	7.23	6.31	ns
	-1	0.56	4.17	0.04	0.86	0.36	4.25	3.46	2.54	2.73	6.15	5.36	ns
	-2	0.49	3.66	0.03	0.76	0.32	3.73	3.04	2.23	2.39	5.40	4.71	ns
8 mA	-F	0.79	5.89	0.05	1.22	0.51	6.00	4.89	3.59	3.85	8.69	7.57	ns
	Std.	0.66	4.91	0.04	1.02	0.43	5.00	4.07	2.99	3.20	7.23	6.31	ns
	-1	0.56	4.17	0.04	0.86	0.36	4.25	3.46	2.54	2.73	6.15	5.36	ns
	-2	0.49	3.66	0.03	0.76	0.32	3.73	3.04	2.23	2.39	5.40	4.71	ns
12 mA	-F	0.79	4.24	0.05	1.22	0.51	4.32	3.39	3.86	4.30	7.01	6.08	ns
	Std.	0.66	3.53	0.04	1.02	0.43	3.60	2.82	3.21	3.58	5.83	5.06	ns
	-1	0.56	3.00	0.04	0.86	0.36	3.06	2.40	2.73	3.05	4.96	4.30	ns
	-2	0.49	2.64	0.03	0.76	0.32	2.69	2.11	2.40	2.68	4.36	3.78	ns
16 mA	-F	0.79	4.00	0.05	1.22	0.51	4.08	3.08	3.92	4.42	6.76	5.77	ns
	Std.	0.66	3.33	0.04	1.02	0.43	3.39	2.56	3.26	3.68	5.63	4.80	ns
	-1	0.56	2.83	0.04	0.86	0.36	2.89	2.18	2.77	3.13	4.79	4.08	ns
	-2	0.49	2.49	0.03	0.76	0.32	2.53	1.91	2.44	2.75	4.20	3.58	ns
24 mA	-F	0.79	3.69	0.05	1.22	0.51	3.76	2.54	3.99	4.88	6.45	5.23	ns
	Std.	0.66	3.08	0.04	1.02	0.43	3.13	2.12	3.32	4.06	5.37	4.35	ns
	-1	0.56	2.62	0.04	0.86	0.36	2.66	1.80	2.83	3.45	4.57	3.70	ns
	-2	0.49	2.30	0.03	0.76	0.32	2.34	1.58	2.48	3.03	4.01	3.25	ns

Notes:

1. Software default selection highlighted in gray.
2. For specific junction temperature and voltage supply levels, refer to [Table 2-6 on page 2-6](#) for derating values.

Table 2-42 • 3.3 V LVTTTL / 3.3 V LVCMOS Low Slew
Commercial-Case Conditions: $T_J = 70^\circ\text{C}$, Worst-Case $V_{CC} = 1.425\text{ V}$, Worst-Case $V_{CCI} = 3.0\text{ V}$
Applicable to Advanced I/O Banks

Drive Strength	Speed Grade	t_{DOUT}	t_{DP}	t_{DIN}	t_{PY}	t_{EOUT}	t_{ZL}	t_{ZH}	t_{LZ}	t_{HZ}	t_{ZLS}	t_{ZHS}	Units
4 mA	-F	0.79	12.32	0.05	1.22	0.51	12.55	10.69	3.18	2.95	15.23	13.37	ns
	Std.	0.66	10.26	0.04	1.02	0.43	10.45	8.90	2.64	2.46	12.68	11.13	ns
	-1	0.56	8.72	0.04	0.86	0.36	8.89	7.57	2.25	2.09	10.79	9.47	ns
	-2	0.49	7.66	0.03	0.76	0.32	7.80	6.64	1.98	1.83	9.47	8.31	ns
6 mA	-F	0.79	8.74	0.05	1.22	0.51	8.90	7.55	3.58	3.65	11.59	10.23	ns
	Std.	0.66	7.27	0.04	1.02	0.43	7.41	6.28	2.98	3.04	9.65	8.52	ns
	-1	0.56	6.19	0.04	0.86	0.36	6.30	5.35	2.54	2.59	8.20	7.25	ns
	-2	0.49	5.43	0.03	0.76	0.32	5.53	4.69	2.23	2.27	7.20	6.36	ns
8 mA	-F	0.79	8.74	0.05	1.22	0.51	8.90	7.55	3.58	3.65	11.59	10.23	ns
	Std.	0.66	7.27	0.04	1.02	0.43	7.41	6.28	2.98	3.04	9.65	8.52	ns
	-1	0.56	6.19	0.04	0.86	0.36	6.30	5.35	2.54	2.59	8.20	7.25	ns
	-2	0.49	5.43	0.03	0.76	0.32	5.53	4.69	2.23	2.27	7.20	6.36	ns
12 mA	-F	0.79	6.70	0.05	1.22	0.51	6.83	5.85	3.85	4.10	9.51	8.54	ns
	Std.	0.66	5.58	0.04	1.02	0.43	5.68	4.87	3.21	3.42	7.92	7.11	ns
	-1	0.56	4.75	0.04	0.86	0.36	4.84	4.14	2.73	2.91	6.74	6.05	ns
	-2	0.49	4.17	0.03	0.76	0.32	4.24	3.64	2.39	2.55	5.91	5.31	ns
16 mA	-F	0.79	6.25	0.05	1.22	0.51	6.37	5.48	3.91	4.22	9.06	8.17	ns
	Std.	0.66	5.21	0.04	1.02	0.43	5.30	4.56	3.26	3.51	7.54	6.80	ns
	-1	0.56	4.43	0.04	0.86	0.36	4.51	3.88	2.77	2.99	6.41	5.79	ns
	-2	0.49	3.89	0.03	0.76	0.32	3.96	3.41	2.43	2.62	5.63	5.08	ns
24 mA	-F	0.79	5.83	0.05	1.22	0.51	5.93	5.46	3.98	4.67	8.62	8.15	ns
	Std.	0.66	4.85	0.04	1.02	0.43	4.94	4.54	3.32	3.88	7.18	6.78	ns
	-1	0.56	4.13	0.04	0.86	0.36	4.20	3.87	2.82	3.30	6.10	5.77	ns
	-2	0.49	3.62	0.03	0.76	0.32	3.69	3.39	2.48	2.90	5.36	5.06	ns

Note: For specific junction temperature and voltage supply levels, refer to [Table 2-6 on page 2-6](#) for derating values.

Table 2-43 • 3.3 V LVTTTL / 3.3 V LVCMOS High Slew
Commercial-Case Conditions: $T_J = 70^\circ\text{C}$, Worst-Case $V_{CC} = 1.425\text{ V}$, Worst-Case $V_{CCI} = 3.0\text{ V}$
Applicable to Standard Plus I/O Banks

Drive Strength	Speed Grade	t_{DOUT}	t_{DP}	t_{DIN}	t_{PY}	t_{EOUT}	t_{ZL}	t_{ZH}	t_{LZ}	t_{HZ}	t_{ZLS}	t_{ZHS}	Units
4 mA	-F	0.79	8.65	0.05	1.20	0.51	8.81	7.55	2.73	2.81	11.50	10.24	ns
	Std.	0.66	7.20	0.04	1.00	0.43	7.34	6.29	2.27	2.34	9.57	8.52	ns
	-1	0.56	6.13	0.04	0.85	0.36	6.24	5.35	1.93	1.99	8.14	7.25	ns
	-2	0.49	5.38	0.03	0.75	0.32	5.48	4.69	1.70	1.75	7.15	6.36	ns
6 mA	-F	0.79	5.41	0.05	1.20	0.51	5.51	4.58	3.10	3.45	8.19	7.27	ns
	Std.	0.66	4.50	0.04	1.00	0.43	4.58	3.82	2.58	2.88	6.82	6.05	ns
	-1	0.56	3.83	0.04	0.85	0.36	3.90	3.25	2.19	2.45	5.80	5.15	ns
	-2	0.49	3.36	0.03	0.75	0.32	3.42	2.85	1.92	2.15	5.09	4.52	ns
8 mA	-F	0.79	5.41	0.05	1.20	0.51	5.51	4.58	3.10	3.45	8.19	7.27	ns
	Std.	0.66	4.50	0.04	1.00	0.43	4.58	3.82	2.58	2.88	6.82	6.05	ns
	-1	0.56	3.83	0.04	0.85	0.36	3.90	3.25	2.19	2.45	5.80	5.15	ns
	-2	0.49	3.36	0.03	0.75	0.32	3.42	2.85	1.92	2.15	5.09	4.52	ns
12 mA	-F	0.79	3.80	0.05	1.20	0.51	3.87	3.10	3.35	3.87	6.55	5.79	ns
	Std.	0.66	3.16	0.04	1.00	0.43	3.22	2.58	2.79	3.22	5.45	4.82	ns
	-1	0.56	2.69	0.04	0.85	0.36	2.74	2.20	2.37	2.74	4.64	4.10	ns
	-2	0.49	2.36	0.03	0.75	0.32	2.40	1.93	2.08	2.41	4.07	3.60	ns
16 mA	-F	0.79	3.80	0.05	1.20	0.51	3.87	3.10	3.35	3.87	6.55	5.79	ns
	Std.	0.66	3.16	0.04	1.00	0.43	3.22	2.58	2.79	3.22	5.45	4.82	ns
	-1	0.56	2.69	0.04	0.85	0.36	2.74	2.20	2.37	2.74	4.64	4.10	ns
	-2	0.49	2.36	0.03	0.75	0.32	2.40	1.93	2.08	2.41	4.07	3.60	ns

Notes:

1. Software default selection highlighted in gray.
1. For specific junction temperature and voltage supply levels, refer to [Table 2-6 on page 2-6](#) for derating values.

Table 2-44 • 3.3 V LVTTTL / 3.3 V LVCMOS Low Slew
Commercial-Case Conditions: $T_J = 70^\circ\text{C}$, Worst-Case $V_{CC} = 1.425\text{ V}$, Worst-Case $V_{CCI} = 3.0\text{ V}$
Applicable to Standard Plus I/O Banks

Drive Strength	Speed Grade	t_{DOUT}	t_{DP}	t_{DIN}	t_{PY}	t_{EOUT}	t_{ZL}	t_{ZH}	t_{LZ}	t_{HZ}	t_{ZLS}	t_{ZHS}	Units
4 mA	-F	0.79	11.63	0.05	1.20	0.51	11.84	10.12	2.74	2.65	14.53	12.81	ns
	Std.	0.66	9.68	0.04	1.00	0.43	9.86	8.42	2.28	2.21	12.09	10.66	ns
	-1	0.56	8.23	0.04	0.85	0.36	8.39	7.17	1.94	1.88	10.29	9.07	ns
	-2	0.49	7.23	0.03	0.75	0.32	7.36	6.29	1.70	1.65	9.03	7.96	ns
6 mA	-F	0.79	8.05	0.05	1.20	0.51	8.20	7.07	3.10	3.29	10.88	9.76	ns
	Std.	0.66	6.70	0.04	1.00	0.43	6.82	5.89	2.58	2.74	9.06	8.12	ns
	-1	0.56	5.70	0.04	0.85	0.36	5.80	5.01	2.20	2.33	7.71	6.91	ns
	-2	0.49	5.00	0.03	0.75	0.32	5.10	4.40	1.93	2.05	6.76	6.06	ns
8 mA	-F	0.79	8.05	0.05	1.20	0.51	8.20	7.07	3.10	3.29	10.88	9.76	ns
	Std.	0.66	6.70	0.04	1.00	0.43	6.82	5.89	2.58	2.74	9.06	8.12	ns
	-1	0.56	5.70	0.04	0.85	0.36	5.80	5.01	2.20	2.33	7.71	6.91	ns
	-2	0.49	5.00	0.03	0.75	0.32	5.10	4.40	1.93	2.05	6.76	6.06	ns
12 mA	-F	0.79	6.06	0.05	1.20	0.51	6.18	5.42	3.35	3.70	8.86	8.10	ns
	Std.	0.66	5.05	0.04	1.00	0.43	5.14	4.51	2.79	3.08	7.38	6.75	ns
	-1	0.56	4.29	0.04	0.85	0.36	4.37	3.84	2.38	2.62	6.28	5.74	ns
	-2	0.49	3.77	0.03	0.75	0.32	3.84	3.37	2.09	2.30	5.51	5.04	ns
16 mA	-F	0.79	6.06	0.05	1.20	0.51	6.18	5.42	3.35	3.70	8.86	8.10	ns
	Std.	0.66	5.05	0.04	1.00	0.43	5.14	4.51	2.79	3.08	7.38	6.75	ns
	-1	0.56	4.29	0.04	0.85	0.36	4.37	3.84	2.38	2.62	6.28	5.74	ns
	-2	0.49	3.77	0.03	0.75	0.32	3.84	3.37	2.09	2.30	5.51	5.04	ns

Note: For specific junction temperature and voltage supply levels, refer to [Table 2-6 on page 2-6](#) for derating values.

Table 2-45 • 3.3 V LVTTTL / 3.3 V LVCMOS High Slew
Commercial-Case Conditions: $T_J = 70^\circ\text{C}$, Worst-Case $V_{CC} = 1.425\text{ V}$, Worst-Case $V_{CCI} = 3.0\text{ V}$
Applicable to Standard I/O Banks

Drive Strength	Speed Grade	t_{DOUT}	t_{DP}	t_{DIN}	t_{PY}	t_{EOUT}	t_{ZL}	t_{ZH}	t_{LZ}	t_{HZ}	Units
2 mA	-F	0.79	8.49	0.05	1.20	0.51	8.65	7.48	2.49	2.58	ns
	Std.	0.66	7.07	0.04	1.00	0.43	7.20	6.23	2.07	2.15	ns
	-1	0.56	6.01	0.04	0.85	0.36	6.12	5.30	1.76	1.83	ns
	-2	0.49	5.28	0.03	0.75	0.32	5.37	4.65	1.55	1.60	ns
4 mA	-F	0.79	8.49	0.05	1.20	0.51	8.65	7.48	2.49	2.58	ns
	Std.	0.66	7.07	0.04	1.00	0.43	7.20	6.23	2.07	2.15	ns
	-1	0.56	6.01	0.04	0.85	0.36	6.12	5.30	1.76	1.83	ns
	-2	0.49	5.28	0.03	0.75	0.32	5.37	4.65	1.55	1.60	ns
6 mA	-F	0.79	5.30	0.05	1.20	0.51	5.40	4.51	2.88	3.23	ns
	Std.	0.66	4.41	0.04	1.00	0.43	4.49	3.75	2.39	2.69	ns
	-1	0.56	3.75	0.04	0.85	0.36	3.82	3.19	2.04	2.29	ns
	-2	0.49	3.29	0.03	0.75	0.32	3.36	2.80	1.79	2.01	ns
8 mA	-F	0.79	5.30	0.05	1.20	0.51	5.40	4.51	2.88	3.23	ns
	Std.	0.66	4.41	0.04	1.00	0.43	4.49	3.75	2.39	2.69	ns
	-1	0.56	3.75	0.04	0.85	0.36	3.82	3.19	2.04	2.29	ns
	-2	0.49	3.29	0.03	0.75	0.32	3.36	2.80	1.79	2.01	ns

Notes:

1. Software default selection highlighted in gray.
2. For specific junction temperature and voltage supply levels, refer to [Table 2-6 on page 2-6](#) for derating values.

Table 2-46 • 3.3 V LVTTTL / 3.3 V LVCMOS Low Slew
Commercial-Case Conditions: $T_J = 70^\circ\text{C}$, Worst-Case $V_{CC} = 1.425\text{ V}$, Worst-Case $V_{CCI} = 3.0\text{ V}$
Applicable to Standard I/O Banks

Drive Strength	Speed Grade	t_{DOUT}	t_{DP}	t_{DIN}	t_{PY}	t_{EOUT}	t_{ZL}	t_{ZH}	t_{LZ}	t_{HZ}	Units
2 mA	-F	0.79	11.37	0.05	1.20	0.51	11.58	10.26	2.49	2.45	ns
	Std.	0.66	9.46	0.04	1.00	0.43	9.64	8.54	2.07	2.04	ns
	-1	0.56	8.05	0.04	0.85	0.36	8.20	7.27	1.76	1.73	ns
	-2	0.49	7.07	0.03	0.75	0.32	7.20	6.38	1.55	1.52	ns
4 mA	-F	0.79	11.37	0.05	1.20	0.51	11.58	10.26	2.49	2.45	ns
	Std.	0.66	9.46	0.04	1.00	0.43	9.64	8.54	2.07	2.04	ns
	-1	0.56	8.05	0.04	0.85	0.36	8.20	7.27	1.76	1.73	ns
	-2	0.49	7.07	0.03	0.75	0.32	7.20	6.38	1.55	1.52	ns
6 mA	-F	0.79	7.89	0.05	1.20	0.51	8.04	7.19	2.88	3.09	ns
	Std.	0.66	6.57	0.04	1.00	0.43	6.69	5.98	2.40	2.57	ns
	-1	0.56	5.59	0.04	0.85	0.36	5.69	5.09	2.04	2.19	ns
	-2	0.49	4.91	0.03	0.75	0.32	5.00	4.47	1.79	1.92	ns
8 mA	-F	0.79	7.89	0.05	1.20	0.51	8.04	7.19	2.88	3.09	ns
	Std.	0.66	6.57	0.04	1.00	0.43	6.69	5.98	2.40	2.57	ns
	-1	0.56	5.59	0.04	0.85	0.36	5.69	5.09	2.04	2.19	ns
	-2	0.49	4.91	0.03	0.75	0.32	5.00	4.47	1.79	1.92	ns

Note: For specific junction temperature and voltage supply levels, refer to [Table 2-6 on page 2-6](#) for derating values.

2.5 V LVCMOS

Low-Voltage CMOS for 2.5 V is an extension of the LVCMOS standard (JESD8-5) used for general-purpose 2.5 V applications. It uses a 5 V-tolerant input buffer and push-pull output buffer.

Table 2-47 • Minimum and Maximum DC Input and Output Levels
Applicable to Advanced I/O Banks

2.5 V LVCMOS	V _{IL}		V _{IH}		V _{OL}	V _{OH}	I _{OL}	I _{OH}	I _{OSL}	I _{OSH}	I _{IL}	I _{IH}
	Min., V	Max., V	Min., V	Max., V	Max., V	Min., V	mA	mA	Max., mA ¹	Max., mA ¹	μA ²	μA ²
2 mA	-0.3	0.7	1.7	3.6	0.7	1.7	2	2	18	16	10	10
4 mA	-0.3	0.7	1.7	3.6	0.7	1.7	4	4	18	16	10	10
6 mA	-0.3	0.7	1.7	3.6	0.7	1.7	6	6	37	32	10	10
8 mA	-0.3	0.7	1.7	3.6	0.7	1.7	8	8	37	32	10	10
12 mA	-0.3	0.7	1.7	3.6	0.7	1.7	12	12	74	65	10	10
16 mA	-0.3	0.7	1.7	3.6	0.7	1.7	16	16	87	83	10	10
24 mA	-0.3	0.7	1.7	3.6	0.7	1.7	24	24	124	169	10	10

Notes:

1. Currents are measured at high temperature (100°C junction temperature) and maximum voltage.
2. Currents are measured at 85°C junction temperature.
3. Software default selection highlighted in gray.

Table 2-48 • Minimum and Maximum DC Input and Output Levels
Applicable to Standard Plus I/O Banks

2.5 V LVCMOS	V _{IL}		V _{IH}		V _{OL}	V _{OH}	I _{OL}	I _{OH}	I _{OSL}	I _{OSH}	I _{IL}	I _{IH}
	Min., V	Max., V	Min., V	Max., V	Max., V	Min., V	mA	mA	Max., mA ¹	Max., mA ¹	μA ²	μA ²
2 mA	-0.3	0.7	1.7	3.6	0.7	1.7	2	2	18	16	10	10
4 mA	-0.3	0.7	1.7	3.6	0.7	1.7	4	4	18	16	10	10
6 mA	-0.3	0.7	1.7	3.6	0.7	1.7	6	6	37	32	10	10
8 mA	-0.3	0.7	1.7	3.6	0.7	1.7	8	8	37	32	10	10
12 mA	-0.3	0.7	1.7	3.6	0.7	1.7	12	12	74	65	10	10

Notes:

1. Currents are measured at high temperature (100°C junction temperature) and maximum voltage.
2. Currents are measured at 85°C junction temperature.
3. Software default selection highlighted in gray.

Table 2-49 • Minimum and Maximum DC Input and Output Levels
Applicable to Standard I/O Banks

2.5 V LVCMOS Drive Strength	V_{IL}		V_{IH}		V_{OL}	V_{OH}	I_{OL}	I_{OH}	I_{OSL}	I_{OSH}	I_{IL}	I_{IH}
	Min., V	Max., V	Min., V	Max., V	Max., V	Min., V	mA	mA	Max., mA ¹	Max., mA ¹	μA^2	μA^2
2 mA	-0.3	0.7	1.7	3.6	0.7	1.7	2	2	16	18	10	10
4 mA	-0.3	0.7	1.7	3.6	0.7	1.7	4	4	16	18	10	10
6 mA	-0.3	0.7	1.7	3.6	0.7	1.7	6	6	32	37	10	10
8 mA	-0.3	0.7	1.7	3.6	0.7	1.7	8	8	32	37	10	10

Notes:

1. Currents are measured at high temperature (100°C junction temperature) and maximum voltage.
2. Currents are measured at 85°C junction temperature.
3. Software default selection highlighted in gray.

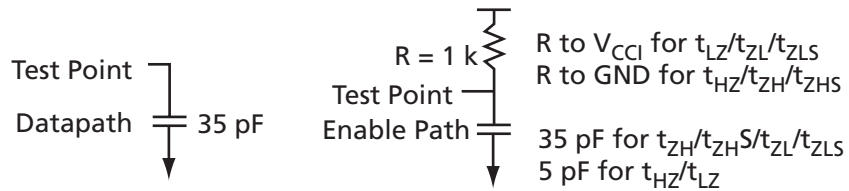

Figure 2-7 • AC Loading

Table 2-50 • AC Waveforms, Measuring Points, and Capacitive Loads

Input LOW (V)	Input HIGH (V)	Measuring Point* (V)	C _{LOAD} (pF)
0	2.5	1.2	35

* Measuring point = V_{trip}. See Table 2-22 on page 2-20 for a complete table of trip points.

Timing Characteristics

Table 2-51 • 2.5 V LVCMOS High Slew

Commercial-Case Conditions: $T_J = 70^\circ\text{C}$, Worst-Case $V_{CC} = 1.425\text{ V}$, Worst-Case $V_{CCI} = 2.3\text{ V}$
 Applicable to Advanced I/O Banks

Drive Strength	Speed Grade	t_{DOUT}	t_{DP}	t_{DIN}	t_{PY}	t_{EOUT}	t_{ZL}	t_{ZH}	t_{LZ}	t_{HZ}	t_{ZLS}	t_{ZHS}	Units
4 mA	-F	0.72	10.41	0.05	1.57	0.51	9.41	10.41	3.22	2.77	12.09	13.09	ns
	Std.	0.60	8.66	0.04	1.31	0.43	7.83	8.66	2.68	2.30	10.07	10.90	ns
	-1	0.51	7.37	0.04	1.11	0.36	6.66	7.37	2.28	1.96	8.56	9.27	ns
	-2	0.45	6.47	0.03	0.98	0.32	5.85	6.47	2.00	1.72	7.52	8.14	ns
6 mA	-F	0.72	6.21	0.05	1.57	0.51	6.05	6.21	3.66	3.60	8.74	8.89	ns
	Std.	0.60	5.17	0.04	1.31	0.43	5.04	5.17	3.05	3.00	7.27	7.40	ns
	-1	0.51	4.39	0.04	1.11	0.36	4.28	4.39	2.59	2.55	6.19	6.30	ns
	-2	0.45	3.86	0.03	0.98	0.32	3.76	3.86	2.28	2.24	5.43	5.53	ns
8 mA	-F	0.72	6.21	0.05	1.57	0.51	6.05	6.21	3.66	3.60	8.74	8.89	ns
	Std.	0.60	5.17	0.04	1.31	0.43	5.04	5.17	3.05	3.00	7.27	7.40	ns
	-1	0.51	4.39	0.04	1.11	0.36	4.28	4.39	2.59	2.55	6.19	6.30	ns
	-2	0.45	3.86	0.03	0.98	0.32	3.76	3.86	2.28	2.24	5.43	5.53	ns
12 mA	-F	0.72	4.28	0.05	1.57	0.51	4.36	4.12	3.97	4.13	7.04	6.81	ns
	Std.	0.60	3.56	0.04	1.31	0.43	3.63	3.43	3.30	3.44	5.86	5.67	ns
	-1	0.51	3.03	0.04	1.11	0.36	3.08	2.92	2.81	2.92	4.99	4.82	ns
	-2	0.45	2.66	0.03	0.98	0.32	2.71	2.56	2.47	2.57	4.38	4.23	ns
16 mA	-F	0.72	4.03	0.05	1.57	0.51	4.10	3.68	4.04	4.26	6.79	6.36	ns
	Std.	0.60	3.35	0.04	1.31	0.43	3.41	3.06	3.36	3.55	5.65	5.30	ns
	-1	0.51	2.85	0.04	1.11	0.36	2.90	2.60	2.86	3.02	4.81	4.51	ns
	-2	0.45	2.50	0.03	0.98	0.32	2.55	2.29	2.51	2.65	4.22	3.96	ns
24 mA	-F	0.72	3.71	0.05	1.57	0.51	3.78	2.93	4.13	4.80	6.47	5.62	ns
	Std.	0.60	3.09	0.04	1.31	0.43	3.15	2.44	3.44	4.00	5.38	4.68	ns
	-1	0.51	2.63	0.04	1.11	0.36	2.68	2.08	2.92	3.40	4.58	3.98	ns
	-2	0.45	2.31	0.03	0.98	0.32	2.35	1.82	2.57	2.98	4.02	3.49	ns

Notes:

1. Software default selection highlighted in gray.
2. For specific junction temperature and voltage supply levels, refer to Table 2-6 on page 2-6 for derating values.

Table 2-52 • 2.5 V LVC MOS Low Slew
 Commercial-Case Conditions: $T_J = 70^\circ\text{C}$, Worst-Case $V_{CC} = 1.425\text{ V}$, Worst-Case $V_{CCI} = 2.3\text{ V}$
 Applicable to Advanced I/O Banks

Drive Strength	Speed Grade	t_{DOUT}	t_{DP}	t_{DIN}	t_{PY}	t_{EOUT}	t_{ZL}	t_{ZH}	t_{LZ}	t_{HZ}	t_{ZLS}	t_{ZHS}	Units
4 mA	–F	0.72	13.69	0.05	1.57	0.51	13.48	13.69	3.22	2.65	16.16	16.38	ns
	Std.	0.60	11.40	0.04	1.31	0.43	11.22	11.40	2.68	2.20	13.45	13.63	ns
	–1	0.51	9.69	0.04	1.11	0.36	9.54	9.69	2.28	1.88	11.44	11.60	ns
	–2	0.45	8.51	0.03	0.98	0.32	8.38	8.51	2.00	1.65	10.05	10.18	ns
6 mA	–F	0.72	9.56	0.05	1.57	0.51	9.74	9.39	3.66	3.47	12.43	12.07	ns
	Std.	0.60	7.96	0.04	1.31	0.43	8.11	7.81	3.05	2.89	10.34	10.05	ns
	–1	0.51	6.77	0.04	1.11	0.36	6.90	6.65	2.59	2.46	8.80	8.55	ns
	–2	0.45	5.94	0.03	0.98	0.32	6.05	5.84	2.28	2.16	7.72	7.50	ns
8 mA	–F	0.72	9.56	0.05	1.57	0.51	9.74	9.39	3.66	3.47	12.43	12.07	ns
	Std.	0.60	7.96	0.04	1.31	0.43	8.11	7.81	3.05	2.89	10.34	10.05	ns
	–1	0.51	6.77	0.04	1.11	0.36	6.90	6.65	2.59	2.46	8.80	8.55	ns
	–2	0.45	5.94	0.03	0.98	0.32	6.05	5.84	2.28	2.16	7.72	7.50	ns
12 mA	–F	0.72	7.42	0.05	1.57	0.51	7.56	7.11	3.97	3.99	10.25	9.80	ns
	Std.	0.60	6.18	0.04	1.31	0.43	6.29	5.92	3.30	3.32	8.53	8.15	ns
	–1	0.51	5.26	0.04	1.11	0.36	5.35	5.03	2.81	2.83	7.26	6.94	ns
	–2	0.45	4.61	0.03	0.98	0.32	4.70	4.42	2.47	2.48	6.37	6.09	ns
16 mA	–F	0.72	6.92	0.05	1.57	0.51	7.05	6.64	4.04	4.13	9.74	9.32	ns
	Std.	0.60	5.76	0.04	1.31	0.43	5.87	5.53	3.36	3.44	8.11	7.76	ns
	–1	0.51	4.90	0.04	1.11	0.36	4.99	4.70	2.86	2.92	6.90	6.60	ns
	–2	0.45	4.30	0.03	0.98	0.32	4.38	4.13	2.51	2.57	6.05	5.80	ns
24 mA	–F	0.72	6.61	0.05	1.57	0.51	6.61	6.61	4.13	4.65	9.30	9.30	ns
	Std.	0.60	5.51	0.04	1.31	0.43	5.50	5.51	3.43	3.87	7.74	7.74	ns
	–1	0.51	4.68	0.04	1.11	0.36	4.68	4.68	2.92	3.29	6.58	6.59	ns
	–2	0.45	4.11	0.03	0.98	0.32	4.11	4.11	2.56	2.89	5.78	5.78	ns

Note: For specific junction temperature and voltage supply levels, refer to Table 2-6 on page 2-6 for derating values.

Table 2-53 • 2.5 V LVC MOS High Slew
Commercial-Case Conditions: $T_J = 70^\circ\text{C}$, Worst-Case $V_{CC} = 1.425\text{ V}$, Worst-Case $V_{CCI} = 2.3\text{ V}$
Applicable to Standard Plus I/O Banks

Drive Strength	Speed Grade	t_{DOUT}	t_{DP}	t_{DIN}	t_{PY}	t_{EOUT}	t_{ZL}	t_{ZH}	t_{LZ}	t_{HZ}	t_{ZLS}	t_{ZHS}	Units
4 mA	-F	0.79	9.94	0.05	1.56	0.51	8.90	9.94	2.70	2.49	11.58	12.63	ns
	Std.	0.66	8.28	0.04	1.30	0.43	7.41	8.28	2.25	2.07	9.64	10.51	ns
	-1	0.56	7.04	0.04	1.10	0.36	6.30	7.04	1.92	1.76	8.20	8.94	ns
	-2	0.49	6.18	0.03	0.97	0.32	5.53	6.18	1.68	1.55	7.20	7.85	ns
6 mA	-F	0.79	5.83	0.05	1.56	0.51	5.58	5.83	3.11	3.26	8.27	8.52	ns
	Std.	0.66	4.85	0.04	1.30	0.43	4.65	4.85	2.59	2.71	6.88	7.09	ns
	-1	0.56	4.13	0.04	1.10	0.36	3.95	4.13	2.20	2.31	5.85	6.03	ns
	-2	0.49	3.62	0.03	0.97	0.32	3.47	3.62	1.93	2.02	5.14	5.29	ns
8 mA	-F	0.79	5.83	0.05	1.56	0.51	5.58	5.83	3.11	3.26	8.27	8.52	ns
	Std.	0.66	4.85	0.04	1.30	0.43	4.65	4.85	2.59	2.71	6.88	7.09	ns
	-1	0.56	4.13	0.04	1.10	0.36	3.95	4.13	2.20	2.31	5.85	6.03	ns
	-2	0.49	3.62	0.03	0.97	0.32	3.47	3.62	1.93	2.02	5.14	5.29	ns
12 mA	-F	0.79	3.85	0.05	1.56	0.51	3.92	3.77	3.39	3.74	6.61	6.46	ns
	Std.	0.66	3.21	0.04	1.30	0.43	3.27	3.14	2.82	3.11	5.50	5.38	ns
	-1	0.56	2.73	0.04	1.10	0.36	2.78	2.67	2.40	2.65	4.68	4.57	ns
	-2	0.49	2.39	0.03	0.97	0.32	2.44	2.35	2.11	2.32	4.11	4.02	ns

Notes:

1. Software default selection highlighted in gray.
2. For specific junction temperature and voltage supply levels, refer to [Table 2-6 on page 2-6](#) for derating values.

Table 2-54 • 2.5 V LVC MOS Low Slew
 Commercial-Case Conditions: $T_J = 70^\circ\text{C}$, Worst-Case $V_{CC} = 1.425\text{ V}$, Worst-Case $V_{CCI} = 2.3\text{ V}$
 Applicable to Standard Plus I/O Banks

Drive Strength	Speed Grade	t_{DOUT}	t_{DP}	t_{DIN}	t_{PY}	t_{EOUT}	t_{ZL}	t_{ZH}	t_{LZ}	t_{HZ}	t_{ZLS}	t_{ZHS}	Units
4 mA	-F	0.79	13.02	0.05	1.56	0.51	12.78	13.02	2.71	2.39	15.46	15.71	ns
	Std.	0.66	10.84	0.04	1.30	0.43	10.64	10.84	2.26	1.99	12.87	13.08	ns
	-1	0.56	9.22	0.04	1.10	0.36	9.05	9.22	1.92	1.69	10.95	11.12	ns
	-2	0.49	8.10	0.03	0.97	0.32	7.94	8.10	1.68	1.49	9.61	9.77	ns
6 mA	-F	0.79	8.85	0.05	1.56	0.51	9.01	8.84	3.11	3.14	11.70	11.53	ns
	Std.	0.66	7.37	0.04	1.30	0.43	7.50	7.36	2.59	2.61	9.74	9.60	ns
	-1	0.56	6.27	0.04	1.10	0.36	6.38	6.26	2.20	2.22	8.29	8.16	ns
	-2	0.49	5.50	0.03	0.97	0.32	5.60	5.50	1.93	1.95	7.27	7.17	ns
8 mA	-F	0.79	8.85	0.05	1.56	0.51	9.01	8.84	3.11	3.14	11.70	11.53	ns
	Std.	0.66	7.37	0.04	1.30	0.43	7.50	7.36	2.59	2.61	9.74	9.60	ns
	-1	0.56	6.27	0.04	1.10	0.36	6.38	6.26	2.20	2.22	8.29	8.16	ns
	-2	0.49	5.50	0.03	0.97	0.32	5.60	5.50	1.93	1.95	7.27	7.17	ns
12 mA	-F	0.79	6.76	0.05	1.56	0.51	6.89	6.61	3.40	3.62	9.57	9.30	ns
	Std.	0.66	5.63	0.04	1.30	0.43	5.73	5.51	2.83	3.01	7.97	7.74	ns
	-1	0.56	4.79	0.04	1.10	0.36	4.88	4.68	2.41	2.56	6.78	6.59	ns
	-2	0.49	4.20	0.03	0.97	0.32	4.28	4.11	2.11	2.25	5.95	5.78	ns

Note: For specific junction temperature and voltage supply levels, refer to [Table 2-6 on page 2-6](#) for derating values.

Table 2-55 • 2.5 V LVC MOS High Slew
 Commercial-Case Conditions: $T_J = 70^\circ\text{C}$, Worst-Case $V_{CC} = 1.425\text{ V}$, Worst-Case $V_{CCI} = 3.0\text{ V}$
 Applicable to Standard I/O Banks

Drive Strength	Speed Grade	t_{DOUT}	t_{DP}	t_{DIN}	t_{PY}	t_{EOUT}	t_{ZL}	t_{ZH}	t_{LZ}	t_{HZ}	Units
2 mA	-F	0.79	9.86	0.05	1.55	0.51	8.70	9.86	2.44	2.29	ns
	Std.	0.66	8.20	0.04	1.29	0.43	7.24	8.20	2.03	1.91	ns
	-1	0.56	6.98	0.04	1.10	0.36	6.16	6.98	1.73	1.62	ns
	-2	0.49	6.13	0.03	0.96	0.32	5.41	6.13	1.52	1.43	ns
4 mA	-F	0.79	9.86	0.05	1.55	0.51	8.70	9.86	2.44	2.29	ns
	Std.	0.66	8.20	0.04	1.29	0.43	7.24	8.20	2.03	1.91	ns
	-1	0.56	6.98	0.04	1.10	0.36	6.16	6.98	1.73	1.62	ns
	-2	0.49	6.13	0.03	0.96	0.32	5.41	6.13	1.52	1.43	ns
6 mA	-F	0.79	5.72	0.05	1.55	0.51	5.47	5.72	2.86	3.07	ns
	Std.	0.66	4.77	0.04	1.29	0.43	4.55	4.77	2.38	2.55	ns
	-1	0.56	4.05	0.04	1.10	0.36	3.87	4.05	2.03	2.17	ns
	-2	0.49	3.56	0.03	0.96	0.32	3.40	3.56	1.78	1.91	ns
8 mA	-F	0.79	5.72	0.05	1.55	0.51	5.47	5.72	2.86	3.07	ns
	Std.	0.66	4.77	0.04	1.29	0.43	4.55	4.77	2.38	2.55	ns
	-1	0.56	4.05	0.04	1.10	0.36	3.87	4.05	2.03	2.17	ns
	-2	0.49	3.56	0.03	0.96	0.32	3.40	3.56	1.78	1.91	ns

Notes:

1. Software default selection highlighted in gray.
2. For specific junction temperature and voltage supply levels, refer to [Table 2-6 on page 2-6](#) for derating values.

Table 2-56 • 2.5 V LVC MOS Low Slew
Commercial-Case Conditions: $T_J = 70^\circ\text{C}$, Worst-Case $V_{CC} = 1.425\text{ V}$, Worst-Case $V_{CCI} = 3.0\text{ V}$
Applicable to Standard I/O Banks

Drive Strength	Speed Grade	t_{DOUT}	t_{DP}	t_{DIN}	t_{PY}	t_{EOUT}	t_{ZL}	t_{ZH}	t_{LZ}	t_{HZ}	Units
2 mA	–F	0.79	13.21	0.05	1.55	0.51	12.46	13.21	2.44	2.20	ns
	Std.	0.66	11.00	0.04	1.29	0.43	10.37	11.00	2.03	1.83	ns
	–1	0.56	9.35	0.04	1.10	0.36	8.83	9.35	1.73	1.56	ns
	–2	0.49	8.21	0.03	0.96	0.32	7.75	8.21	1.52	1.37	ns
4 mA	–F	0.79	13.21	0.05	1.55	0.51	12.46	13.21	2.44	2.20	ns
	Std.	0.66	11.00	0.04	1.29	0.43	10.37	11.00	2.03	1.83	ns
	–1	0.56	9.35	0.04	1.10	0.36	8.83	9.35	1.73	1.56	ns
	–2	0.49	8.21	0.03	0.96	0.32	7.75	8.21	1.52	1.37	ns
6 mA	–F	0.79	9.01	0.05	1.55	0.51	8.84	9.01	2.87	2.96	ns
	Std.	0.66	7.50	0.04	1.29	0.43	7.36	7.50	2.39	2.46	ns
	–1	0.56	6.38	0.04	1.10	0.36	6.26	6.38	2.03	2.10	ns
	–2	0.49	5.60	0.03	0.96	0.32	5.49	5.60	1.78	1.84	ns
8 mA	–F	0.79	9.01	0.05	1.55	0.51	8.84	9.01	2.87	2.96	ns
	Std.	0.66	7.50	0.04	1.29	0.43	7.36	7.50	2.39	2.46	ns
	–1	0.56	6.38	0.04	1.10	0.36	6.26	6.38	2.03	2.10	ns
	–2	0.49	5.60	0.03	0.96	0.32	5.49	5.60	1.78	1.84	ns

Note: For specific junction temperature and voltage supply levels, refer to [Table 2-6 on page 2-6](#) for derating values.

1.8 V LVCMOS

Low-voltage CMOS for 1.8 V is an extension of the LVCMOS standard (JESD8-5) used for general-purpose 1.8 V applications. It uses a 1.8 V input buffer and a push-pull output buffer.

Table 2-57 • Minimum and Maximum DC Input and Output Levels
Applicable to Advanced I/O Banks

1.8 V LVCMOS	V_{IL}		V_{IH}		V_{OL}	V_{OH}	I_{OL}	I_{OH}	I_{OSL}	I_{OSH}	I_{IL}	I_{IH}
	Min., V	Max., V	Min., V	Max., V	Max., V	Min., V	mA	mA	Max., mA ¹	Max., mA ¹	μA ²	μA ²
2 mA	-0.3	$0.35 * V_{CCI}$	$0.65 * V_{CCI}$	3.6	0.45	$V_{CCI} - 0.45$	2	2	11	9	10	10
4 mA	-0.3	$0.35 * V_{CCI}$	$0.65 * V_{CCI}$	3.6	0.45	$V_{CCI} - 0.45$	4	4	22	17	10	10
6 mA	-0.3	$0.35 * V_{CCI}$	$0.65 * V_{CCI}$	3.6	0.45	$V_{CCI} - 0.45$	6	6	44	35	10	10
8 mA	-0.3	$0.35 * V_{CCI}$	$0.65 * V_{CCI}$	3.6	0.45	$V_{CCI} - 0.45$	8	8	51	45	10	10
12 mA	-0.3	$0.35 * V_{CCI}$	$0.65 * V_{CCI}$	3.6	0.45	$V_{CCI} - 0.45$	12	12	74	91	10	10
16 mA	-0.3	$0.35 * V_{CCI}$	$0.65 * V_{CCI}$	3.6	0.45	$V_{CCI} - 0.45$	16	16	74	91	10	10

Notes:

1. Currents are measured at high temperature (100°C junction temperature) and maximum voltage.
2. Currents are measured at 85°C junction temperature.
3. Software default selection highlighted in gray.

Table 2-58 • Minimum and Maximum DC Input and Output Levels
Applicable to Standard Plus I/O Banks

1.8 V LVCMOS	V_{IL}		V_{IH}		V_{OL}	V_{OH}	I_{OL}	I_{OH}	I_{OSL}	I_{OSH}	I_{IL}	I_{IH}
	Min., V	Max., V	Min., V	Max., V	Max., V	Min., V	mA	mA	Max., mA ¹	Max., mA ¹	μA ²	μA ²
2 mA	-0.3	$0.35 * V_{CCI}$	$0.65 * V_{CCI}$	3.6	0.45	$V_{CCI} - 0.45$	2	2	11	9	10	10
4 mA	-0.3	$0.35 * V_{CCI}$	$0.65 * V_{CCI}$	3.6	0.45	$V_{CCI} - 0.45$	4	4	22	17	10	10
6 mA	-0.3	$0.35 * V_{CCI}$	$0.65 * V_{CCI}$	3.6	0.45	$V_{CCI} - 0.45$	6	6	44	35	10	10
8 mA	-0.3	$0.35 * V_{CCI}$	$0.65 * V_{CCI}$	3.6	0.45	$V_{CCI} - 0.45$	8	8	44	35	10	10

Notes:

1. Currents are measured at high temperature (100°C junction temperature) and maximum voltage.
2. Currents are measured at 85°C junction temperature.
3. Software default selection highlighted in gray.

**Table 2-59 • Minimum and Maximum DC Input and Output Levels
Applicable to Standard I/O Banks**

1.8 V LVCMOS	V_{IL}		V_{IH}		V_{OL}	V_{OH}	I_{OL}	I_{OH}	I_{OSL}	I_{OSH}	I_{IL}	I_{IH}
	Min., V	Max., V	Min., V	Max., V	Max., V	Min., V	mA	mA	Max., mA ¹	Max., mA ¹	μA^2	μA^2
2 mA	-0.3	$0.35 * V_{CC1}$	$0.65 * V_{CC1}$	3.6	0.45	$V_{CC1} - 0.45$	2	2	9	11	10	10
4 mA	-0.3	$0.35 * V_{CC1}$	$0.65 * V_{CC1}$	3.6	0.45	$V_{CC1} - 0.45$	4	4	17	22	10	10

Notes:

1. Currents are measured at high temperature (100°C junction temperature) and maximum voltage.
2. Currents are measured at 85°C junction temperature.
3. Software default selection highlighted in gray.

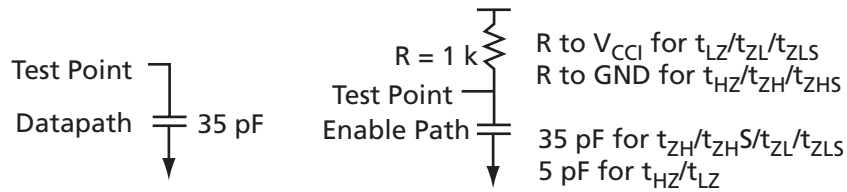

Figure 2-8 • AC Loading

Table 2-60 • AC Waveforms, Measuring Points, and Capacitive Loads

Input LOW (V)	Input HIGH (V)	Measuring Point* (V)	C_{LOAD} (pF)
0	1.8	0.9	35

* Measuring point = V_{trip} . See Table 2-22 on page 2-20 for a complete table of trip points.

Timing Characteristics

Table 2-61 • 1.8 V LVC MOS High Slew
 Commercial-Case Conditions: $T_J = 70^\circ\text{C}$, Worst-Case $V_{CC} = 1.425\text{ V}$, Worst-Case $V_{CCI} = 1.7\text{ V}$
 Applicable to Advanced I/O Banks

Drive Strength	Speed Grade	t_{DOUT}	t_{DP}	t_{DIN}	t_{PY}	t_{EOUT}	t_{ZL}	t_{ZH}	t_{LZ}	t_{HZ}	t_{ZLS}	t_{ZHS}	Units
2 mA	-F	0.79	14.25	0.05	1.46	0.51	10.97	14.25	3.33	1.99	13.66	16.94	ns
	Std.	0.66	11.86	0.04	1.22	0.43	9.14	11.86	2.77	1.66	11.37	14.10	ns
	-1	0.56	10.09	0.04	1.04	0.36	7.77	10.09	2.36	1.41	9.67	11.99	ns
	-2	0.49	8.86	0.03	0.91	0.32	6.82	8.86	2.07	1.24	8.49	10.53	ns
4 mA	-F	0.79	8.31	0.05	1.46	0.51	7.04	8.31	3.87	3.41	9.73	10.99	ns
	Std.	0.66	6.91	0.04	1.22	0.43	5.86	6.91	3.22	2.84	8.10	9.15	ns
	-1	0.56	5.88	0.04	1.04	0.36	4.99	5.88	2.74	2.41	6.89	7.78	ns
	-2	0.49	5.16	0.03	0.91	0.32	4.38	5.16	2.41	2.12	6.05	6.83	ns
6 mA	-F	0.79	5.34	0.05	1.46	0.51	5.02	5.34	4.24	4.06	7.71	8.03	ns
	Std.	0.66	4.45	0.04	1.22	0.43	4.18	4.45	3.53	3.38	6.42	6.68	ns
	-1	0.56	3.78	0.04	1.04	0.36	3.56	3.78	3.00	2.88	5.46	5.69	ns
	-2	0.49	3.32	0.03	0.91	0.32	3.12	3.32	2.64	2.53	4.79	4.99	ns
8 mA	-F	0.79	4.71	0.05	1.46	0.51	4.72	4.71	4.32	4.23	7.40	7.40	ns
	Std.	0.66	3.92	0.04	1.22	0.43	3.93	3.92	3.60	3.52	6.16	6.16	ns
	-1	0.56	3.34	0.04	1.04	0.36	3.34	3.34	3.06	3.00	5.24	5.24	ns
	-2	0.49	2.93	0.03	0.91	0.32	2.93	2.93	2.69	2.63	4.60	4.60	ns
12 mA	-F	0.79	4.24	0.05	1.46	0.51	4.32	3.65	4.45	4.90	7.01	6.34	ns
	Std.	0.66	3.53	0.04	1.22	0.43	3.60	3.04	3.70	4.08	5.84	5.28	ns
	-1	0.56	3.01	0.04	1.04	0.36	3.06	2.59	3.15	3.47	4.96	4.49	ns
	-2	0.49	2.64	0.03	0.91	0.32	2.69	2.27	2.76	3.05	4.36	3.94	ns
16 mA	-F	0.79	4.24	0.05	1.46	0.51	4.32	3.65	4.45	4.90	7.01	6.34	ns
	Std.	0.66	3.53	0.04	1.22	0.43	3.60	3.04	3.70	4.08	5.84	5.28	ns
	-1	0.56	3.01	0.04	1.04	0.36	3.06	2.59	3.15	3.47	4.96	4.49	ns
	-2	0.49	2.64	0.03	0.91	0.32	2.69	2.27	2.76	3.05	4.36	3.94	ns

Notes:

1. Software default selection highlighted in gray.
2. For specific junction temperature and voltage supply levels, refer to [Table 2-6 on page 2-6](#) for derating values.

Table 2-62 • 1.8 V LVC MOS Low Slew
 Commercial-Case Conditions: $T_J = 70^\circ\text{C}$, Worst-Case $V_{CC} = 1.425\text{ V}$, Worst-Case $V_{CCI} = 1.7\text{ V}$
 Applicable to Advanced I/O Banks

Drive Strength	Speed Grade	t_{DOUT}	t_{DP}	t_{DIN}	t_{PY}	t_{EOUT}	t_{ZL}	t_{ZH}	t_{LZ}	t_{HZ}	t_{ZLS}	t_{ZHS}	Units
2 mA	-F	0.79	18.66	0.05	1.46	0.51	16.95	18.66	3.34	1.92	19.64	21.34	ns
	Std.	0.66	15.53	0.04	1.22	0.43	14.11	15.53	2.78	1.60	16.35	17.77	ns
	-1	0.56	13.21	0.04	1.04	0.36	12.01	13.21	2.36	1.36	13.91	15.11	ns
	-2	0.49	11.60	0.03	0.91	0.32	10.54	11.60	2.07	1.19	12.21	13.27	ns
4 mA	-F	0.79	12.58	0.05	1.46	0.51	12.51	12.58	3.88	3.28	15.19	15.27	ns
	Std.	0.66	10.48	0.04	1.22	0.43	10.41	10.48	3.23	2.73	12.65	12.71	ns
	-1	0.56	8.91	0.04	1.04	0.36	8.86	8.91	2.75	2.33	10.76	10.81	ns
	-2	0.49	7.82	0.03	0.91	0.32	7.77	7.82	2.41	2.04	9.44	9.49	ns
6 mA	-F	0.79	9.67	0.05	1.46	0.51	9.85	9.42	4.25	3.93	12.53	12.11	ns
	Std.	0.66	8.05	0.04	1.22	0.43	8.20	7.84	3.54	3.27	10.43	10.08	ns
	-1	0.56	6.85	0.04	1.04	0.36	6.97	6.67	3.01	2.78	8.88	8.57	ns
	-2	0.49	6.01	0.03	0.91	0.32	6.12	5.86	2.64	2.44	7.79	7.53	ns
8 mA	-F	0.79	9.01	0.05	1.46	0.51	9.18	8.77	4.33	4.10	11.87	11.45	ns
	Std.	0.66	7.50	0.04	1.22	0.43	7.64	7.30	3.61	3.41	9.88	9.53	ns
	-1	0.56	6.38	0.04	1.04	0.36	6.50	6.21	3.07	2.90	8.40	8.11	ns
	-2	0.49	5.60	0.03	0.91	0.32	5.71	5.45	2.69	2.55	7.38	7.12	ns
12 mA	-F	0.79	8.76	0.05	1.46	0.51	8.69	8.76	4.45	4.74	11.38	11.45	ns
	Std.	0.66	7.29	0.04	1.22	0.43	7.23	7.29	3.71	3.95	9.47	9.53	ns
	-1	0.56	6.20	0.04	1.04	0.36	6.15	6.20	3.15	3.36	8.06	8.11	ns
	-2	0.49	5.45	0.03	0.91	0.32	5.40	5.45	2.77	2.95	7.07	7.12	ns
16 mA	-F	0.79	8.76	0.05	1.46	0.51	8.69	8.76	4.45	4.74	11.38	11.45	ns
	Std.	0.66	7.29	0.04	1.22	0.43	7.23	7.29	3.71	3.95	9.47	9.53	ns
	-1	0.56	6.20	0.04	1.04	0.36	6.15	6.20	3.15	3.36	8.06	8.11	ns
	-2	0.49	5.45	0.03	0.91	0.32	5.40	5.45	2.77	2.95	7.07	7.12	ns

Note: For specific junction temperature and voltage supply levels, refer to Table 2-6 on page 2-6 for derating values.



Table 2-63 • 1.8 V LVC MOS High Slew
Commercial-Case Conditions: $T_J = 70^\circ\text{C}$, Worst-Case $V_{CC} = 1.425\text{ V}$, Worst-Case $V_{CCI} = 1.7\text{ V}$
Applicable to Standard Plus I/O Banks

Drive Strength	Speed Grade	t_{DOUT}	t_{DP}	t_{DIN}	t_{PY}	t_{EOUT}	t_{ZL}	t_{ZH}	t_{LZ}	t_{HZ}	t_{ZLS}	t_{ZHS}	Units
2 mA	-F	0.79	13.61	0.05	1.44	0.51	10.48	13.61	2.70	1.83	13.17	16.30	ns
	Std.	0.66	11.33	0.04	1.20	0.43	8.72	11.33	2.24	1.52	10.96	13.57	ns
	-1	0.56	9.64	0.04	1.02	0.36	7.42	9.64	1.91	1.29	9.32	11.54	ns
	-2	0.49	8.46	0.03	0.90	0.32	6.51	8.46	1.68	1.14	8.18	10.13	ns
4 mA	-F	0.79	7.79	0.05	1.44	0.51	6.58	7.79	3.18	3.13	9.27	10.47	ns
	Std.	0.66	6.48	0.04	1.20	0.43	5.48	6.48	2.65	2.60	7.72	8.72	ns
	-1	0.56	5.51	0.04	1.02	0.36	4.66	5.51	2.25	2.21	6.56	7.42	ns
	-2	0.49	4.84	0.03	0.90	0.32	4.09	4.84	1.98	1.94	5.76	6.51	ns
6 mA	-F	0.79	4.88	0.05	1.44	0.51	4.61	4.88	3.52	3.73	7.30	7.56	ns
	Std.	0.66	4.06	0.04	1.20	0.43	3.84	4.06	2.93	3.10	6.07	6.30	ns
	-1	0.56	3.45	0.04	1.02	0.36	3.27	3.45	2.49	2.64	5.17	5.36	ns
	-2	0.49	3.03	0.03	0.90	0.32	2.87	3.03	2.19	2.32	4.54	4.70	ns
8 mA	-F	0.79	4.88	0.05	1.44	0.51	4.61	4.88	3.52	3.73	7.30	7.56	ns
	Std.	0.66	4.06	0.04	1.20	0.43	3.84	4.06	2.93	3.10	6.07	6.30	ns
	-1	0.56	3.45	0.04	1.02	0.36	3.27	3.45	2.49	2.64	5.17	5.36	ns
	-2	0.49	3.03	0.03	0.90	0.32	2.87	3.03	2.19	2.32	4.54	4.70	ns

Notes:

1. Software default selection highlighted in gray.
2. For specific junction temperature and voltage supply levels, refer to [Table 2-6 on page 2-6](#) for derating values.

Table 2-64 • 1.8 V LVC MOS Low Slew
 Commercial-Case Conditions: $T_J = 70^\circ\text{C}$, Worst-Case $V_{CC} = 1.425\text{ V}$, Worst-Case $V_{CCI} = 1.7\text{ V}$
 Applicable to Standard Plus I/O Banks

Drive Strength	Speed Grade	t_{DOUT}	t_{DP}	t_{DIN}	t_{PY}	t_{EOUT}	t_{ZL}	t_{ZH}	t_{LZ}	t_{HZ}	t_{ZLS}	t_{ZHS}	Units
2 mA	-F	0.79	17.78	0.05	1.44	0.51	16.21	17.78	2.70	1.76	18.90	20.47	ns
	Std.	0.66	14.80	0.04	1.20	0.43	13.49	14.80	2.25	1.46	15.73	17.04	ns
	-1	0.56	12.59	0.04	1.02	0.36	11.48	12.59	1.91	1.25	13.38	14.49	ns
	-2	0.49	11.05	0.03	0.90	0.32	10.08	11.05	1.68	1.09	11.75	12.72	ns
4 mA	-F	0.79	11.89	0.05	1.44	0.51	11.69	11.89	3.19	3.00	14.38	14.58	ns
	Std.	0.66	9.90	0.04	1.20	0.43	9.73	9.90	2.65	2.50	11.97	12.13	ns
	-1	0.56	8.42	0.04	1.02	0.36	8.28	8.42	2.26	2.12	10.18	10.32	ns
	-2	0.49	7.39	0.03	0.90	0.32	7.27	7.39	1.98	1.86	8.94	9.06	ns
6 mA	-F	0.79	8.93	0.05	1.44	0.51	9.10	8.79	3.53	3.59	11.79	11.48	ns
	Std.	0.66	7.44	0.04	1.20	0.43	7.58	7.32	2.94	2.99	9.81	9.56	ns
	-1	0.56	6.33	0.04	1.02	0.36	6.44	6.23	2.50	2.54	8.35	8.13	ns
	-2	0.49	5.55	0.03	0.90	0.32	5.66	5.47	2.19	2.23	7.33	7.14	ns
8 mA	-F	0.79	8.93	0.05	1.44	0.51	9.10	8.79	3.53	3.59	11.79	11.48	ns
	Std.	0.66	7.44	0.04	1.20	0.43	7.58	7.32	2.94	2.99	9.81	9.56	ns
	-1	0.56	6.33	0.04	1.02	0.36	6.44	6.23	2.50	2.54	8.35	8.13	ns
	-2	0.49	5.55	0.03	0.90	0.32	5.66	5.47	2.19	2.23	7.33	7.14	ns

Note: For specific junction temperature and voltage supply levels, refer to Table 2-6 on page 2-6 for derating values.

Table 2-65 • 1.8 V LVC MOS High Slew
 Commercial-Case Conditions: $T_J = 70^\circ\text{C}$, Worst-Case $V_{CC} = 1.425\text{ V}$, Worst-Case $V_{CCI} = 3.0\text{ V}$
 Applicable to Standard I/O Banks

Drive Strength	Speed Grade	t_{DOUT}	t_{DP}	t_{DIN}	t_{PY}	t_{EOUT}	t_{ZL}	t_{ZH}	t_{LZ}	t_{HZ}	Units
2 mA	-F	0.79	13.47	0.05	1.44	0.51	10.25	13.47	2.39	1.45	ns
	Std.	0.66	11.21	0.04	1.20	0.43	8.53	11.21	1.99	1.21	ns
	-1	0.56	9.54	0.04	1.02	0.36	7.26	9.54	1.69	1.03	ns
	-2	0.49	8.37	0.03	0.90	0.32	6.37	8.37	1.49	0.90	ns
4 mA	-F	0.79	7.62	0.05	1.44	0.51	6.46	7.62	2.89	2.98	ns
	Std.	0.66	6.34	0.04	1.20	0.43	5.38	6.34	2.41	2.48	ns
	-1	0.56	5.40	0.04	1.02	0.36	4.58	5.40	2.05	2.11	ns
	-2	0.49	4.74	0.03	0.90	0.32	4.02	4.74	1.80	1.85	ns

Notes:

1. Software default selection highlighted in gray.
2. For specific junction temperature and voltage supply levels, refer to Table 2-6 on page 2-6 for derating values.



Table 2-66 • 1.8 V LVCMOS Low Slew
 Commercial-Case Conditions: $T_J = 70^\circ\text{C}$, Worst-Case $V_{CC} = 1.425\text{ V}$, Worst-Case $V_{CCI} = 3.0\text{ V}$
 Applicable to Standard I/O Banks

Drive Strength	Speed Grade	t_{DOUT}	t_{DP}	t_{DIN}	t_{PY}	t_{EOUT}	t_{ZL}	t_{ZH}	t_{LZ}	t_{HZ}	Units
2 mA	–F	0.79	18.03	0.05	1.44	0.51	15.80	18.03	2.40	2.40	ns
	Std.	0.66	15.01	0.04	1.20	0.43	13.15	15.01	1.99	1.99	ns
	–1	0.56	12.77	0.04	1.02	0.36	11.19	12.77	1.70	1.70	ns
	–2	0.49	11.21	0.03	0.90	0.32	9.82	11.21	1.49	1.49	ns
4 mA	–F	0.79	12.13	0.05	1.44	0.51	11.48	12.13	2.90	2.85	ns
	Std.	0.66	10.10	0.04	1.20	0.43	9.55	10.10	2.41	2.37	ns
	–1	0.56	8.59	0.04	1.02	0.36	8.13	8.59	2.05	2.02	ns
	–2	0.49	7.54	0.03	0.90	0.32	7.13	7.54	1.80	1.77	ns

Note: For specific junction temperature and voltage supply levels, refer to Table 2-6 on page 2-6 for derating values.

1.5 V LVCMOS (JESD8-11)

Low-Voltage CMOS for 1.5 V is an extension of the LVCMOS standard (JESD8-5) used for general-purpose 1.5 V applications. It uses a 1.5 V input buffer and a push-pull output buffer.

Table 2-67 • Minimum and Maximum DC Input and Output Levels
 Applicable to Advanced I/O Banks

1.5 V LVCMOS	V_{IL}		V_{IH}		V_{OL}	V_{OH}	I_{OL}	I_{OH}	I_{OSL}	I_{OSH}	I_{IL}	I_{IH}
	Min., V	Max., V	Min., V	Max., V	Max., V	Min., V	mA	mA	Max., mA ¹	Max., mA ¹	μA^2	μA^2
2 mA	–0.3	$0.30 * V_{CCI}$	$0.7 * V_{CCI}$	3.6	$0.25 * V_{CCI}$	$0.75 * V_{CCI}$	2	2	16	13	10	10
4 mA	–0.3	$0.30 * V_{CCI}$	$0.7 * V_{CCI}$	3.6	$0.25 * V_{CCI}$	$0.75 * V_{CCI}$	4	4	33	25	10	10
6 mA	–0.3	$0.30 * V_{CCI}$	$0.7 * V_{CCI}$	3.6	$0.25 * V_{CCI}$	$0.75 * V_{CCI}$	6	6	39	32	10	10
8 mA	–0.3	$0.30 * V_{CCI}$	$0.7 * V_{CCI}$	3.6	$0.25 * V_{CCI}$	$0.75 * V_{CCI}$	8	8	55	66	10	10
12 mA	–0.3	$0.30 * V_{CCI}$	$0.7 * V_{CCI}$	3.6	$0.25 * V_{CCI}$	$0.75 * V_{CCI}$	12	12	55	66	10	10

Notes:

1. Currents are measured at high temperature (100°C junction temperature) and maximum voltage.
2. Currents are measured at 85°C junction temperature.
3. Software default selection highlighted in gray.

**Table 2-68 • Minimum and Maximum DC Input and Output Levels
Applicable to Standard Plus I/O Banks**

1.5 V LVCMOS	V _{IL}		V _{IH}		V _{OL}	V _{OH}	I _{OL}	I _{OH}	I _{OSL}	I _{OSH}	I _{IL}	I _{IH}
	Min., V	Max., V	Min., V	Max., V	Max., V	Min., V	mA	mA	Max., mA ¹	Max., mA ¹	μA ²	μA ²
2 mA	-0.3	0.30 * V _{CC1}	0.7 * V _{CC1}	3.6	0.25 * V _{CC1}	0.75 * V _{CC1}	2	2	0	0	10	10
4 mA	-0.3	0.30 * V _{CC1}	0.7 * V _{CC1}	3.6	0.25 * V _{CC1}	0.75 * V _{CC1}	4	4	0	0	10	10

Notes:

1. Currents are measured at high temperature (100°C junction temperature) and maximum voltage.
2. Currents are measured at 85°C junction temperature.
3. Software default selection highlighted in gray.

**Table 2-69 • Minimum and Maximum DC Input and Output Levels
Applicable to Standard I/O Banks**

1.5 V LVCMOS	V _{IL}		V _{IH}		V _{OL}	V _{OH}	I _{OL}	I _{OH}	I _{OSL}	I _{OSH}	I _{IL}	I _{IH}
	Min., V	Max., V	Min., V	Max., V	Max., V	Min., V	mA	mA	Max., mA ¹	Max., mA ¹	μA ²	μA ²
2 mA	-0.3	0.30 * V _{CC1}	0.7 * V _{CC1}	3.6	0.25 * V _{CC1}	0.75 * V _{CC1}	2	2	13	16	10	10

Notes:

1. Currents are measured at high temperature (100°C junction temperature) and maximum voltage.
2. Currents are measured at 85°C junction temperature.
3. Software default selection highlighted in gray.

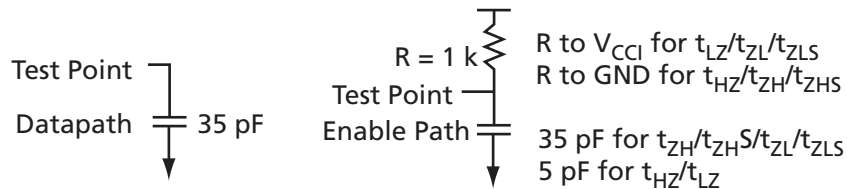

Figure 2-9 • AC Loading

Table 2-70 • AC Waveforms, Measuring Points, and Capacitive Loads

Input LOW (V)	Input HIGH (V)	Measuring Point* (V)	C _{LOAD} (pF)
0	1.5	0.75	35

* Measuring point = V_{trip}. See Table 2-22 on page 2-20 for a complete table of trip points.

Timing Characteristics

Table 2-71 • 1.5 V LVCMOS High Slew
 Commercial-Case Conditions: $T_J = 70^\circ\text{C}$, Worst-Case $V_{CC} = 1.425\text{ V}$, Worst-Case $V_{CCI} = 1.4\text{ V}$
 Applicable to Advanced I/O Banks

Drive Strength	Speed Grade	t_{DOUT}	t_{DP}	t_{DIN}	t_{PY}	t_{EOUT}	t_{ZL}	t_{ZH}	t_{LZ}	t_{HZ}	t_{ZLS}	t_{ZHS}	Units
2 mA	-F	0.79	10.05	0.05	1.73	0.51	8.20	10.05	4.07	3.32	10.88	12.73	ns
	Std.	0.66	8.36	0.04	1.44	0.43	6.82	8.36	3.39	2.77	9.06	10.60	ns
	-1	0.56	7.11	0.04	1.22	0.36	5.80	7.11	2.88	2.35	7.71	9.02	ns
	-2	0.49	6.24	0.03	1.07	0.32	5.10	6.24	2.53	2.06	6.76	7.91	ns
4 mA	-F	0.79	6.38	0.05	1.73	0.51	5.83	6.38	4.49	4.09	8.51	9.07	ns
	Std.	0.66	5.31	0.04	1.44	0.43	4.85	5.31	3.74	3.40	7.09	7.55	ns
	-1	0.56	4.52	0.04	1.22	0.36	4.13	4.52	3.18	2.89	6.03	6.42	ns
	-2	0.49	3.97	0.03	1.07	0.32	3.62	3.97	2.79	2.54	5.29	5.64	ns
6 mA	-F	0.79	5.61	0.05	1.73	0.51	5.46	5.61	4.59	4.28	8.15	8.29	ns
	Std.	0.66	4.67	0.04	1.44	0.43	4.55	4.67	3.82	3.56	6.78	6.90	ns
	-1	0.56	3.97	0.04	1.22	0.36	3.87	3.97	3.25	3.03	5.77	5.87	ns
	-2	0.49	3.49	0.03	1.07	0.32	3.40	3.49	2.85	2.66	5.07	5.16	ns
8 mA	-F	0.79	4.90	0.05	1.73	0.51	4.99	4.30	4.74	5.05	7.68	6.98	ns
	Std.	0.66	4.08	0.04	1.44	0.43	4.15	3.58	3.94	4.20	6.39	5.81	ns
	-1	0.56	3.47	0.04	1.22	0.36	3.53	3.04	3.36	3.58	5.44	4.95	ns
	-2	0.49	3.05	0.03	1.07	0.32	3.10	2.67	2.95	3.14	4.77	4.34	ns
12 mA	-F	0.79	4.90	0.05	1.73	0.51	4.99	4.30	4.74	5.05	7.68	6.98	ns
	Std.	0.66	4.08	0.04	1.44	0.43	4.15	3.58	3.94	4.20	6.39	5.81	ns
	-1	0.56	3.47	0.04	1.22	0.36	3.53	3.04	3.36	3.58	5.44	4.95	ns
	-2	0.49	3.05	0.03	1.07	0.32	3.10	2.67	2.95	3.14	4.77	4.34	ns

Notes:

1. Software default selection highlighted in gray.
2. For specific junction temperature and voltage supply levels, refer to [Table 2-6 on page 2-6](#) for derating values.

Table 2-72 • 1.5 V LVCMOS Low Slew
 Commercial-Case Conditions: $T_J = 70^\circ\text{C}$, Worst-Case $V_{CC} = 1.425\text{ V}$, Worst-Case $V_{CCI} = 1.4\text{ V}$
 Applicable to Advanced I/O Banks

Drive Strength	Speed Grade	t_{DOUT}	t_{DP}	t_{DIN}	t_{PY}	t_{EOUT}	t_{ZL}	t_{ZH}	t_{LZ}	t_{HZ}	t_{ZLS}	t_{ZHS}	Units
2 mA	–F	0.79	15.36	0.05	1.73	0.51	15.39	15.36	4.08	3.18	18.07	18.04	ns
	Std.	0.66	12.78	0.04	1.44	0.43	12.81	12.78	3.40	2.64	15.05	15.02	ns
	–1	0.56	10.87	0.04	1.22	0.36	10.90	10.87	2.89	2.25	12.80	12.78	ns
	–2	0.49	9.55	0.03	1.07	0.32	9.57	9.55	2.54	1.97	11.24	11.22	ns
4 mA	–F	0.79	12.02	0.05	1.73	0.51	12.25	11.47	4.50	3.93	14.93	14.15	ns
	Std.	0.66	10.01	0.04	1.44	0.43	10.19	9.55	3.75	3.27	12.43	11.78	ns
	–1	0.56	8.51	0.04	1.22	0.36	8.67	8.12	3.19	2.78	10.57	10.02	ns
	–2	0.49	7.47	0.03	1.07	0.32	7.61	7.13	2.80	2.44	9.28	8.80	ns
6 mA	–F	0.79	11.21	0.05	1.73	0.51	11.42	10.68	4.60	4.12	14.11	13.37	ns
	Std.	0.66	9.33	0.04	1.44	0.43	9.51	8.89	3.83	3.43	11.74	11.13	ns
	–1	0.56	7.94	0.04	1.22	0.36	8.09	7.56	3.26	2.92	9.99	9.47	ns
	–2	0.49	6.97	0.03	1.07	0.32	7.10	6.64	2.86	2.56	8.77	8.31	ns
8 mA	–F	0.79	10.70	0.05	1.73	0.51	10.90	10.68	4.75	4.86	13.59	13.37	ns
	Std.	0.66	8.91	0.04	1.44	0.43	9.07	8.89	3.95	4.05	11.31	11.13	ns
	–1	0.56	7.58	0.04	1.22	0.36	7.72	7.57	3.36	3.44	9.62	9.47	ns
	–2	0.49	6.65	0.03	1.07	0.32	6.78	6.64	2.95	3.02	8.45	8.31	ns
12 mA	–F	0.79	10.70	0.05	1.73	0.51	10.90	10.68	4.75	4.86	13.59	13.37	ns
	Std.	0.66	8.91	0.04	1.44	0.43	9.07	8.89	3.95	4.05	11.31	11.13	ns
	–1	0.56	7.58	0.04	1.22	0.36	7.72	7.57	3.36	3.44	9.62	9.47	ns
	–2	0.49	6.65	0.03	1.07	0.32	6.78	6.64	2.95	3.02	8.45	8.31	ns

Note: For specific junction temperature and voltage supply levels, refer to [Table 2-6 on page 2-6](#) for derating values.

Table 2-73 • 1.5 V LVCMOS High Slew

Commercial-Case Conditions: $T_J = 70^\circ\text{C}$, Worst-Case $V_{CC} = 1.425\text{ V}$, Worst-Case $V_{CCI} = 1.4\text{ V}$
 Applicable to Standard Plus I/O Banks

Drive Strength	Speed Grade	t_{DOUT}	t_{DP}	t_{DIN}	t_{PY}	t_{EOUT}	t_{ZL}	t_{ZH}	t_{LZ}	t_{HZ}	t_{ZLS}	t_{ZHS}	Units
2 mA	-F	0.79	9.41	0.05	1.71	0.51	7.71	9.41	3.25	3.06	10.40	12.09	ns
	Std.	0.66	7.83	0.04	1.42	0.43	6.42	7.83	2.71	2.55	8.65	10.07	ns
	-1	0.56	6.66	0.04	1.21	0.36	5.46	6.66	2.31	2.17	7.36	8.56	ns
	-2	0.49	5.85	0.03	1.06	0.32	4.79	5.85	2.02	1.90	6.46	7.52	ns
4 mA	-F	0.79	5.81	0.05	1.71	0.51	5.39	5.81	3.64	3.76	8.08	8.50	ns
	Std.	0.66	4.84	0.04	1.42	0.43	4.49	4.84	3.03	3.13	6.72	7.08	ns
	-1	0.56	4.12	0.04	1.21	0.36	3.82	4.12	2.58	2.66	5.72	6.02	ns
	-2	0.49	3.61	0.03	1.06	0.32	3.35	3.61	2.26	2.34	5.02	5.28	ns

Notes:

1. Software default selection highlighted in gray.
2. For specific junction temperature and voltage supply levels, refer to [Table 2-6 on page 2-6](#) for derating values.

Table 2-74 • 1.5 V LVCMOS Low Slew

Commercial-Case Conditions: $T_J = 70^\circ\text{C}$, Worst-Case $V_{CC} = 1.425\text{ V}$, Worst-Case $V_{CCI} = 1.4\text{ V}$
 Applicable to Standard Plus I/O Banks

Drive Strength	Speed Grade	t_{DOUT}	t_{DP}	t_{DIN}	t_{PY}	t_{EOUT}	t_{ZL}	t_{ZH}	t_{LZ}	t_{HZ}	t_{ZLS}	t_{ZHS}	Units
2 mA	-F	0.79	14.51	0.05	1.71	0.51	14.42	14.51	3.26	2.91	17.11	17.20	ns
	Std.	0.66	12.08	0.04	1.42	0.43	12.01	12.08	2.72	2.43	14.24	14.31	ns
	-1	0.56	10.27	0.04	1.21	0.36	10.21	10.27	2.31	2.06	12.12	12.18	ns
	-2	0.49	9.02	0.03	1.06	0.32	8.97	9.02	2.03	1.81	10.64	10.69	ns
4 mA	-F	0.79	11.15	0.05	1.71	0.51	11.35	10.71	3.65	3.60	14.04	13.40	ns
	Std.	0.66	9.28	0.04	1.42	0.43	9.45	8.91	3.04	3.00	11.69	11.15	ns
	-1	0.56	7.89	0.04	1.21	0.36	8.04	7.58	2.58	2.55	9.94	9.49	ns
	-2	0.49	6.93	0.03	1.06	0.32	7.06	6.66	2.27	2.24	8.73	8.33	ns

Note: For specific junction temperature and voltage supply levels, refer to [Table 2-6 on page 2-6](#) for derating values.

Table 2-75 • 1.5 V LVCMOS High Slew
 Commercial-Case Conditions: $T_J = 70^\circ\text{C}$, Worst-Case $V_{CC} = 1.425\text{ V}$, Worst-Case $V_{CCI} = 3.0\text{ V}$
 Applicable to Standard I/O Banks

Drive Strength	Speed Grade	t_{DOUT}	t_{DP}	t_{DIN}	t_{PY}	t_{EOUT}	t_{ZL}	t_{ZH}	t_{LZ}	t_{HZ}	Units
2 mA	-F	0.79	9.18	0.05	1.70	0.51	7.58	9.18	2.94	2.94	ns
	Std.	0.66	7.65	0.04	1.42	0.43	6.31	7.65	2.45	2.45	ns
	-1	0.56	6.50	0.04	1.21	0.36	5.37	6.50	2.08	2.08	ns
	-2	0.49	5.71	0.03	1.06	0.32	4.71	5.71	1.83	1.83	ns

Notes:

1. Software default selection highlighted in gray.
2. For specific junction temperature and voltage supply levels, refer to Table 2-6 on page 2-6 for derating values.

Table 2-76 • 1.5 V LVCMOS Low Slew
 Commercial-Case Conditions: $T_J = 70^\circ\text{C}$, Worst-Case $V_{CC} = 1.425\text{ V}$, Worst-Case $V_{CCI} = 3.0\text{ V}$
 Applicable to Standard I/O Banks

Drive Strength	Speed Grade	t_{DOUT}	t_{DP}	t_{DIN}	t_{PY}	t_{EOUT}	t_{ZL}	t_{ZH}	t_{LZ}	t_{HZ}	Units
2 mA	-F	0.79	14.81	0.05	1.70	0.51	14.17	14.81	2.94	2.79	ns
	Std.	0.66	12.33	0.04	1.42	0.43	11.79	12.33	2.45	2.32	ns
	-1	0.56	10.49	0.04	1.21	0.36	10.03	10.49	2.08	1.98	ns
	-2	0.49	9.21	0.03	1.06	0.32	8.81	9.21	1.83	1.73	ns

Note: For specific junction temperature and voltage supply levels, refer to Table 2-6 on page 2-6 for derating values.

3.3 V PCI, 3.3 V PCI-X

Peripheral Component Interface for 3.3 V standard specifies support for 33 MHz and 66 MHz PCI Bus applications.

Table 2-77 • Minimum and Maximum DC Input and Output Levels

3.3 V PCI/PCI-X	V_{IL}		V_{IH}		V_{OL}	V_{OH}	I_{OL}	I_{OH}	I_{OSL}	I_{OSH}	I_{IL}	I_{IH}
Drive Strength	Min, V	Max, V	Min, V	Max, V	Max, V	Min, V	mA	mA	Max, mA ¹	Max, mA ¹	μA^2	μA^2
Per PCI specification	Per PCI curves										10	10

Notes:

1. Currents are measured at high temperature (100°C junction temperature) and maximum voltage.
2. Currents are measured at 85°C junction temperature.

AC loadings are defined per the PCI/PCI-X specifications for the datapath; Actel loadings for enable path characterization are described in Figure 2-10.

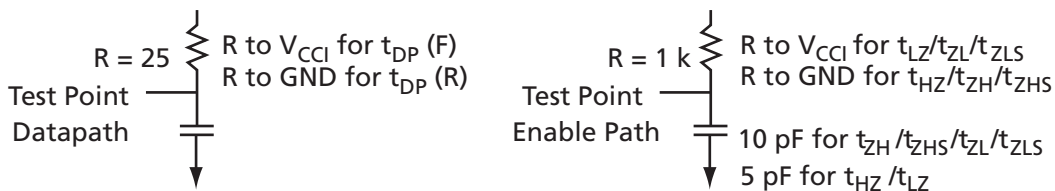

Figure 2-10 • AC Loading



AC loadings are defined per PCI/PCI-X specifications for the datapath; Actel loading for tristate is described in Table 2-78.

Table 2-78 • AC Waveforms, Measuring Points, and Capacitive Loads

Input LOW (V)	Input HIGH (V)	Measuring Point* (V)	C _{LOAD} (pF)
0	3.3	0.285 * V _{CCI} for t _{DP(R)} 0.615 * V _{CCI} for t _{DP(F)}	10

* Measuring point = V_{trip}. See Table 2-22 on page 2-20 for a complete table of trip points.

Timing Characteristics

Table 2-79 • 3.3 V PCI/PCI-X

Commercial-Case Conditions: T_J = 70°C, Worst-Case V_{CC} = 1.425 V, Worst-Case V_{CCI} = 3.0 V
Applicable to Advanced I/O Banks

Speed Grade	t _{DOUT}	t _{DP}	t _{DIN}	t _{PY}	t _{EOUT}	t _{ZL}	t _{ZH}	t _{LZ}	t _{HZ}	t _{ZLS}	t _{ZHS}	Units
-F	0.79	3.22	0.05	1.04	0.51	3.28	2.34	3.86	4.30	5.97	5.03	ns
Std.	0.66	2.68	0.04	0.86	0.43	2.73	1.95	3.21	3.58	4.97	4.19	ns
-1	0.56	2.28	0.04	0.73	0.36	2.32	1.66	2.73	3.05	4.22	3.56	ns
-2	0.49	2.00	0.03	0.65	0.32	2.04	1.46	2.40	2.68	3.71	3.13	ns

Note: For specific junction temperature and voltage supply levels, refer to Table 2-6 on page 2-6 for derating values.

Table 2-80 • 3.3 V PCI/PCI-X

Commercial-Case Conditions: T_J = 70°C, Worst-Case V_{CC} = 1.425 V, Worst-Case V_{CCI} = 3.0 V
Applicable to Standard Plus I/O Banks

Speed Grade	t _{DOUT}	t _{DP}	t _{DIN}	t _{PY}	t _{EOUT}	t _{ZL}	t _{ZH}	t _{LZ}	t _{HZ}	t _{ZLS}	t _{ZHS}	Units
-F	0.79	2.77	0.05	1.02	0.51	2.82	2.05	3.35	3.87	5.51	4.73	ns
Std.	0.66	2.31	0.04	0.85	0.43	2.35	1.70	2.79	3.22	4.59	3.94	ns
-1	0.56	1.96	0.04	0.72	0.36	2.00	1.45	2.37	2.74	3.90	3.35	ns
-2	0.49	1.72	0.03	0.64	0.32	1.76	1.27	2.08	2.41	3.42	2.94	ns

Note: For specific junction temperature and voltage supply levels, refer to Table 2-6 on page 2-6 for derating values.

Differential I/O Characteristics

Physical Implementation

Configuration of the I/O modules as a differential pair is handled by Actel Designer software when the user instantiates a differential I/O macro in the design.

Differential I/Os can also be used in conjunction with the embedded Input Register (InReg), Output Register (OutReg), Enable Register (EnReg), and Double Data Rate (DDR). However, there is no support for bidirectional I/Os or tristates with the LVPECL standards.

LVDS

Low-Voltage Differential Signaling (ANSI/TIA/EIA-644) is a high-speed, differential I/O standard. It requires that one data bit be carried through two signal lines, so two pins are needed. It also requires external resistor termination.

The full implementation of the LVDS transmitter and receiver is shown in an example in [Figure 2-11](#). The building blocks of the LVDS transmitter-receiver are one transmitter macro, one receiver macro, three board resistors at the transmitter end, and one resistor at the receiver end. The values for the three driver resistors are different from those used in the LVPECL implementation because the output standard specifications are different.

Along with LVDS I/O, ProASIC3 also supports Bus LVDS structure and Multipoint LVDS (M-LVDS) configuration (up to 40 nodes).

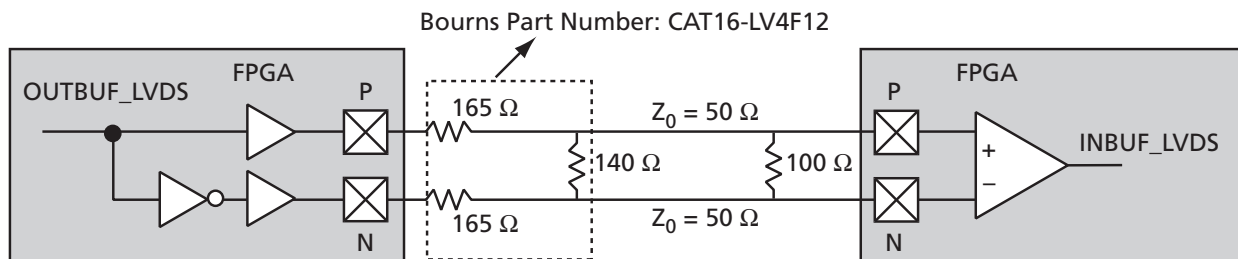

Figure 2-11 • LVDS Circuit Diagram and Board-Level Implementation

Table 2-81 • LVDS Minimum and Maximum DC Input and Output Levels

DC Parameter	Description	Min.	Typ.	Max.	Units
V _{CCI}	Supply Voltage ¹	2.375	2.5	2.625	V
V _{OL}	Output Low Voltage	0.9	1.075	1.25	V
V _{OH}	Output High Voltage	1.25	1.425	1.6	V
I _{OL} ⁴	Output Lower Current	0.65	0.91	1.16	mA
I _{OH} ⁴	Output High Current	0.65	0.91	1.16	mA
V _I	Input Voltage	0		2.925	V
I _{IH} ³	Input High Leakage Current			10	μA
I _{IL} ³	Input Low Leakage Current			10	μA
V _{ODIFF}	Differential Output Voltage	250	350	450	mV
V _{OCM}	Output Common Mode Voltage	1.125	1.25	1.375	V
V _{ICM}	Input Common Mode Voltage	0.05	1.25	2.35	V
V _{IDIFF}	Input Differential Voltage ²	100	350		mV

Notes:

- ±5%
- Differential input voltage = ±350 mV.
- Currents are measured at 85°C junction temperature.
- I_{OL}/I_{OH} defined by V_{ODIFF}/(Resistor Network).

Table 2-82 • AC Waveforms, Measuring Points, and Capacitive Loads

Input LOW (V)	Input HIGH (V)	Measuring Point* (V)
1.075	1.325	Cross point

* Measuring point = V_{trip}. See Table 2-22 on page 2-20 for a complete table of trip points.

Timing Characteristics

Table 2-83 • LVDS

Commercial-Case Conditions: T_J = 70°C, Worst-Case V_{CC} = 1.425 V, Worst-Case V_{CCI} = 2.3 V

Speed Grade	t _{DOUT}	t _{DP}	t _{DIN}	t _{PY}	Units
-F	0.79	2.20	0.05	1.92	ns
Std.	0.66	1.83	0.04	1.60	ns
-1	0.56	1.56	0.04	1.36	ns
-2	0.49	1.37	0.03	1.20	ns

Note: For specific junction temperature and voltage supply levels, refer to Table 2-6 on page 2-6 for derating values.

B-LVDS/M-LVDS

Bus LVDS (B-LVDS) and Multipoint LVDS (M-LVDS) specifications extend the existing LVDS standard to high-performance multipoint bus applications. Multidrop and multipoint bus configurations may contain any combination of drivers, receivers, and transceivers. Actel LVDS drivers provide the higher drive current required by B-LVDS and M-LVDS to accommodate the loading. The drivers require series terminations for better signal quality and to control voltage swing. Termination is also required at both ends of the bus since the driver can be located anywhere on the bus. These configurations can be implemented using the TRIBUF_LVDS and BIBUF_LVDS macros along with appropriate terminations. Multipoint designs using Actel LVDS macros can achieve up to 200 MHz with a maximum of 20 loads. A sample application is given in Figure 2-12. The input and output buffer delays are available in the LVDS section in Table 2-83.

Example: For a bus consisting of 20 equidistant loads, the following terminations provide the required differential voltage, in worst-case Industrial operating conditions, at the farthest receiver: $R_S = 60 \Omega$ and $R_T = 70 \Omega$, given $Z_0 = 50 \Omega$ (2") and $Z_{stubs} = 50 \Omega$ (~1.5").

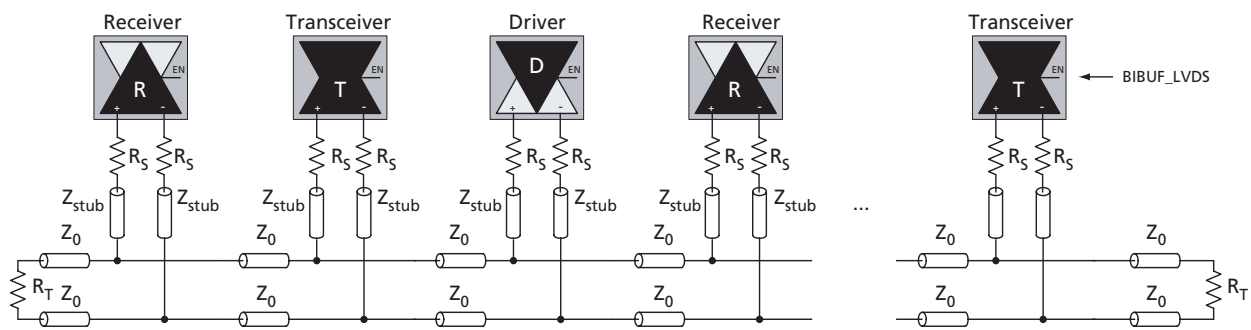

Figure 2-12 • B-LVDS/M-LVDS Multipoint Application Using LVDS I/O Buffers

LVPECL

Low-Voltage Positive Emitter-Coupled Logic (LVPECL) is another differential I/O standard. It requires that one data bit be carried through two signal lines. Like LVDS, two pins are needed. It also requires external resistor termination.

The full implementation of the LVDS transmitter and receiver is shown in an example in Figure 2-13. The building blocks of the LVPECL transmitter-receiver are one transmitter macro, one receiver macro, three board resistors at the transmitter end, and one resistor at the receiver end. The values for the three driver resistors are different from those used in the LVDS implementation because the output standard specifications are different.

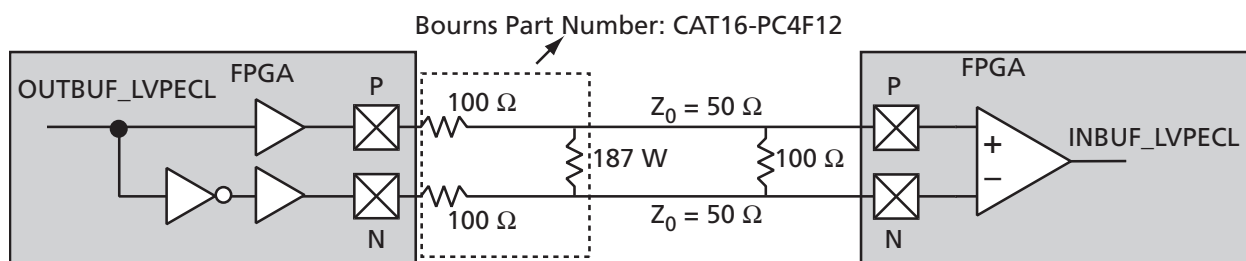

Figure 2-13 • LVPECL Circuit Diagram and Board-Level Implementation

Table 2-84 • Minimum and Maximum DC Input and Output Levels

DC Parameter	Description	Min.	Max.	Min.	Max.	Min.	Max.	Units
V_{CCI}	Supply Voltage	3.0		3.3		3.6		V
V_{OL}	Output LOW Voltage	0.96	1.27	1.06	1.43	1.30	1.57	V
V_{OH}	Output HIGH Voltage	1.8	2.11	1.92	2.28	2.13	2.41	V
V_{IL}, V_{IH}	Input LOW, Input HIGH Voltages	0	3.3	0	3.6	0	3.9	V
V_{ODIFF}	Differential Output Voltage	0.625	0.97	0.625	0.97	0.625	0.97	V
V_{OCM}	Output Common-Mode Voltage	1.762	1.98	1.762	1.98	1.762	1.98	V
V_{ICM}	Input Common-Mode Voltage	1.01	2.57	1.01	2.57	1.01	2.57	V
V_{IDIFF}	Input Differential Voltage	300		300		300		mV

Table 2-85 • AC Waveforms, Measuring Points, and Capacitive Loads

Input LOW (V)	Input HIGH (V)	Measuring Point* (V)
1.64	1.94	Cross point

* Measuring point = V_{trip} . See Table 2-22 on page 2-20 for a complete table of trip points.

Timing Characteristics

Table 2-86 • LVPECL

Commercial-Case Conditions: $T_J = 70^\circ\text{C}$, Worst-Case $V_{CC} = 1.425\text{ V}$, Worst-Case $V_{CCI} = 3.0\text{ V}$

Speed Grade	t_{DOUT}	t_{DP}	t_{DIN}	t_{PY}	Units
-F	0.79	2.16	0.05	1.69	ns
Std.	0.66	1.80	0.04	1.40	ns
-1	0.56	1.53	0.04	1.19	ns
-2	0.49	1.34	0.03	1.05	ns

Note: For specific junction temperature and voltage supply levels, refer to Table 2-6 on page 2-6 for derating values.

I/O Register Specifications

Fully Registered I/O Buffers with Synchronous Enable and Asynchronous Preset

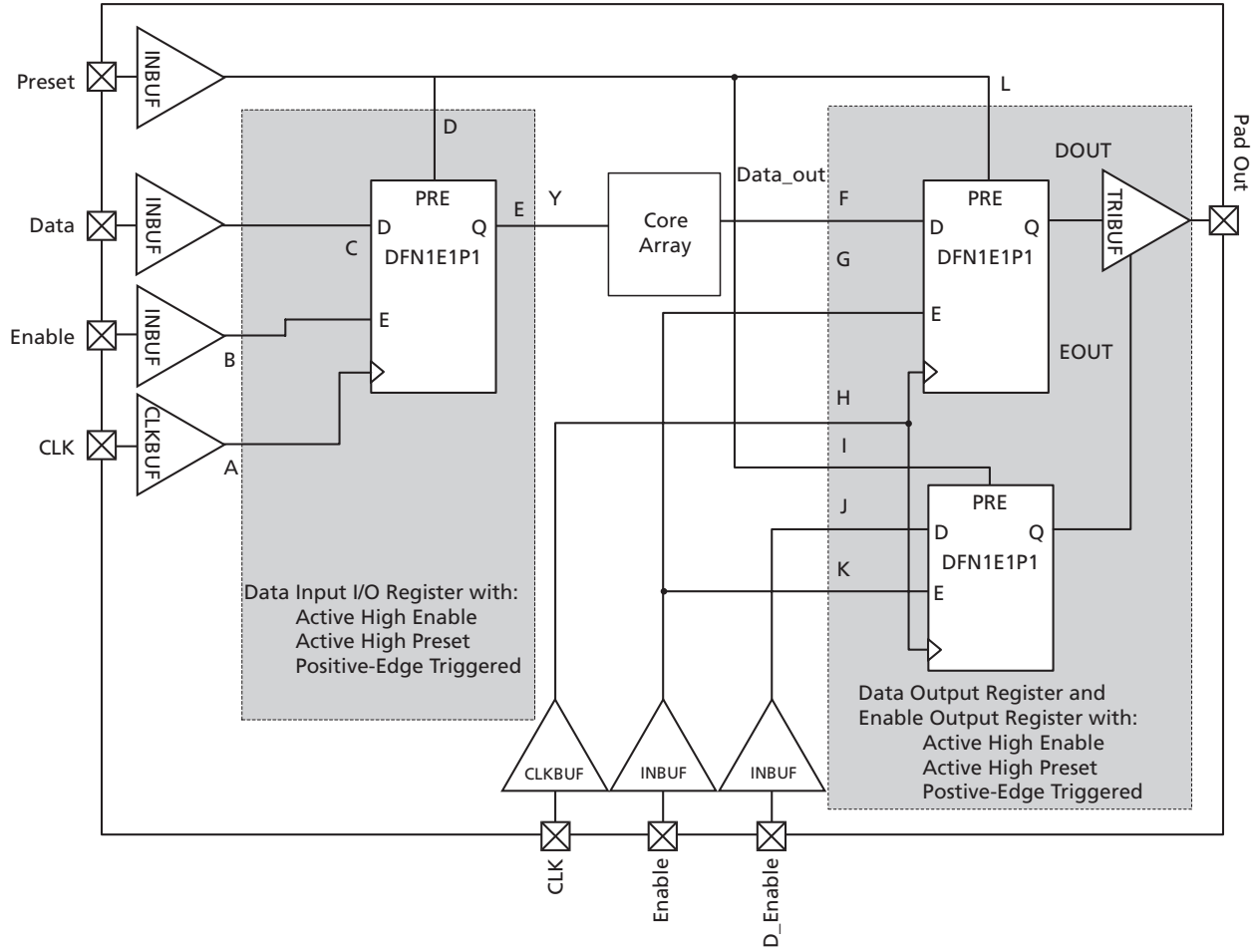

Figure 2-14 • Timing Model of Registered I/O Buffers with Synchronous Enable and Asynchronous Preset

Table 2-87 • Parameter Definition and Measuring Nodes

Parameter Name	Parameter Definition	Measuring Nodes (from, to)*
t _{OCLKQ}	Clock-to-Q of the Output Data Register	H, DOUT
t _{OSUD}	Data Setup Time for the Output Data Register	F, H
t _{OHD}	Data Hold Time for the Output Data Register	F, H
t _{OSUE}	Enable Setup Time for the Output Data Register	G, H
t _{OHE}	Enable Hold Time for the Output Data Register	G, H
t _{OPRE2Q}	Asynchronous Preset-to-Q of the Output Data Register	L, DOUT
t _{OEMPRE}	Asynchronous Preset Removal Time for the Output Data Register	L, H
t _{ORECPRE}	Asynchronous Preset Recovery Time for the Output Data Register	L, H
t _{OECLKQ}	Clock-to-Q of the Output Enable Register	H, EOUT
t _{OESUD}	Data Setup Time for the Output Enable Register	J, H
t _{OEHD}	Data Hold Time for the Output Enable Register	J, H
t _{OESUE}	Enable Setup Time for the Output Enable Register	K, H
t _{OEHE}	Enable Hold Time for the Output Enable Register	K, H
t _{OEPRE2Q}	Asynchronous Preset-to-Q of the Output Enable Register	I, EOUT
t _{OEREMPRE}	Asynchronous Preset Removal Time for the Output Enable Register	I, H
t _{OERECPRE}	Asynchronous Preset Recovery Time for the Output Enable Register	I, H
t _{ICKLKQ}	Clock-to-Q of the Input Data Register	A, E
t _{ISUD}	Data Setup Time for the Input Data Register	C, A
t _{IHD}	Data Hold Time for the Input Data Register	C, A
t _{ISUE}	Enable Setup Time for the Input Data Register	B, A
t _{IHE}	Enable Hold Time for the Input Data Register	B, A
t _{IPRE2Q}	Asynchronous Preset-to-Q of the Input Data Register	D, E
t _{IEMPRE}	Asynchronous Preset Removal Time for the Input Data Register	D, A
t _{IRECPRE}	Asynchronous Preset Recovery Time for the Input Data Register	D, A

* See Figure 2-14 on page 2-62 for more information.

Fully Registered I/O Buffers with Synchronous Enable and Asynchronous Clear

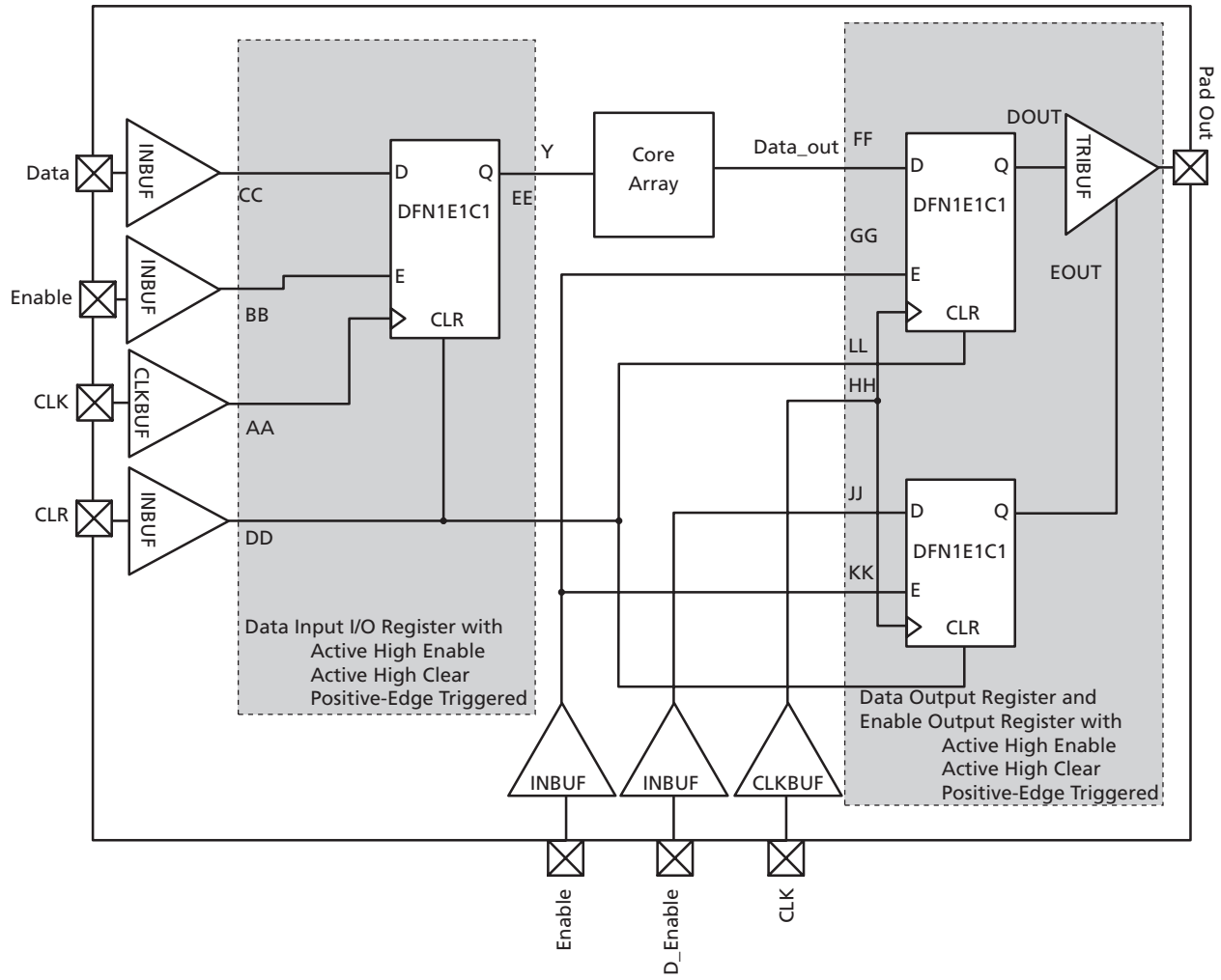

Figure 2-15 • Timing Model of the Registered I/O Buffers with Synchronous Enable and Asynchronous Clear

Table 2-88 • Parameter Definition and Measuring Nodes

Parameter Name	Parameter Definition	Measuring Nodes (from, to)*
t _{OCLKQ}	Clock-to-Q of the Output Data Register	HH, DOUT
t _{OSUD}	Data Setup Time for the Output Data Register	FF, HH
t _{OHD}	Data Hold Time for the Output Data Register	FF, HH
t _{OSUE}	Enable Setup Time for the Output Data Register	GG, HH
t _{OHE}	Enable Hold Time for the Output Data Register	GG, HH
t _{OCLR2Q}	Asynchronous Clear-to-Q of the Output Data Register	LL, DOUT
t _{OREMCLR}	Asynchronous Clear Removal Time for the Output Data Register	LL, HH
t _{ORECCLR}	Asynchronous Clear Recovery Time for the Output Data Register	LL, HH
t _{OELCKQ}	Clock-to-Q of the Output Enable Register	HH, EOUT
t _{OESUD}	Data Setup Time for the Output Enable Register	JJ, HH
t _{OEHd}	Data Hold Time for the Output Enable Register	JJ, HH
t _{OESUE}	Enable Setup Time for the Output Enable Register	KK, HH
t _{OEHdE}	Enable Hold Time for the Output Enable Register	KK, HH
t _{OELCR2Q}	Asynchronous Clear-to-Q of the Output Enable Register	II, EOUT
t _{OEREMCLR}	Asynchronous Clear Removal Time for the Output Enable Register	II, HH
t _{OERECCLR}	Asynchronous Clear Recovery Time for the Output Enable Register	II, HH
t _{ICLKQ}	Clock-to-Q of the Input Data Register	AA, EE
t _{ISUD}	Data Setup Time for the Input Data Register	CC, AA
t _{IHD}	Data Hold Time for the Input Data Register	CC, AA
t _{ISUE}	Enable Setup Time for the Input Data Register	BB, AA
t _{IHE}	Enable Hold Time for the Input Data Register	BB, AA
t _{ICLR2Q}	Asynchronous Clear-to-Q of the Input Data Register	DD, EE
t _{IREMCLR}	Asynchronous Clear Removal Time for the Input Data Register	DD, AA
t _{IRECCLR}	Asynchronous Clear Recovery Time for the Input Data Register	DD, AA

* See Figure 2-15 on page 2-64 for more information.

Input Register

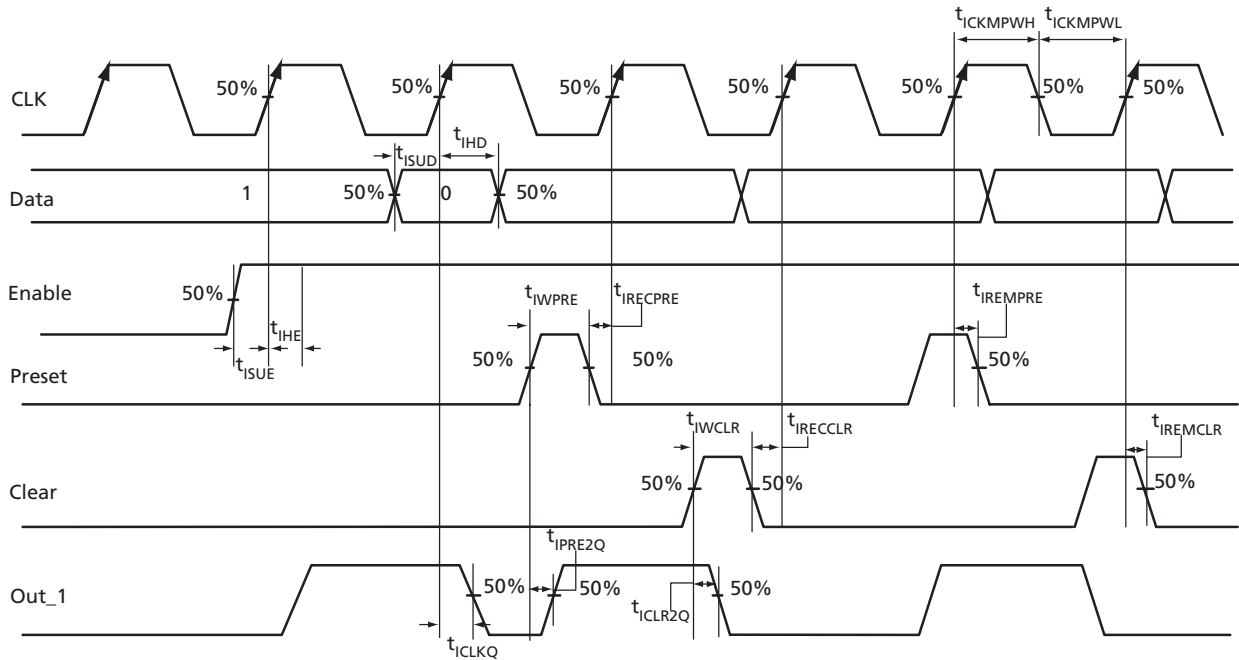

Figure 2-16 • Input Register Timing Diagram

Timing Characteristics

Table 2-89 • Input Data Register Propagation Delays
Commercial-Case Conditions: $T_J = 70^\circ\text{C}$, Worst-Case $V_{CC} = 1.425\text{ V}$

Parameter	Description	-2	-1	Std.	-F	Units
t_{iCLKQ}	Clock-to-Q of the Input Data Register	0.24	0.27	0.32	0.38	ns
t_{iSUD}	Data Setup Time for the Input Data Register	0.26	0.30	0.35	0.42	ns
t_{iHD}	Data Hold Time for the Input Data Register	0.00	0.00	0.00	0.00	ns
t_{iSUE}	Enable Setup Time for the Input Data Register	0.37	0.42	0.50	0.60	ns
t_{iHE}	Enable Hold Time for the Input Data Register	0.00	0.00	0.00	0.00	ns
t_{iCLR2Q}	Asynchronous Clear-to-Q of the Input Data Register	0.45	0.52	0.61	0.73	ns
t_{iPRE2Q}	Asynchronous Preset-to-Q of the Input Data Register	0.45	0.52	0.61	0.73	ns
$t_{iREMCLR}$	Asynchronous Clear Removal Time for the Input Data Register	0.00	0.00	0.00	0.00	ns
t_{iRECLR}	Asynchronous Clear Recovery Time for the Input Data Register	0.22	0.25	0.30	0.36	ns
$t_{iREMPRE}$	Asynchronous Preset Removal Time for the Input Data Register	0.00	0.00	0.00	0.00	ns
$t_{iRECPRE}$	Asynchronous Preset Recovery Time for the Input Data Register	0.22	0.25	0.30	0.36	ns
t_{iWCLR}	Asynchronous Clear Minimum Pulse Width for the Input Data Register	0.22	0.25	0.30	0.36	ns
t_{iWPRES}	Asynchronous Preset Minimum Pulse Width for the Input Data Register	0.22	0.25	0.30	0.36	ns
$t_{iCKMPWH}$	Clock Minimum Pulse Width HIGH for the Input Data Register	0.36	0.41	0.48	0.57	ns
$t_{iCKMPWL}$	Clock Minimum Pulse Width LOW for the Input Data Register	0.32	0.37	0.43	0.52	ns

Note: For specific junction temperature and voltage supply levels, refer to Table 2-6 on page 2-6 for derating values.



Output Register

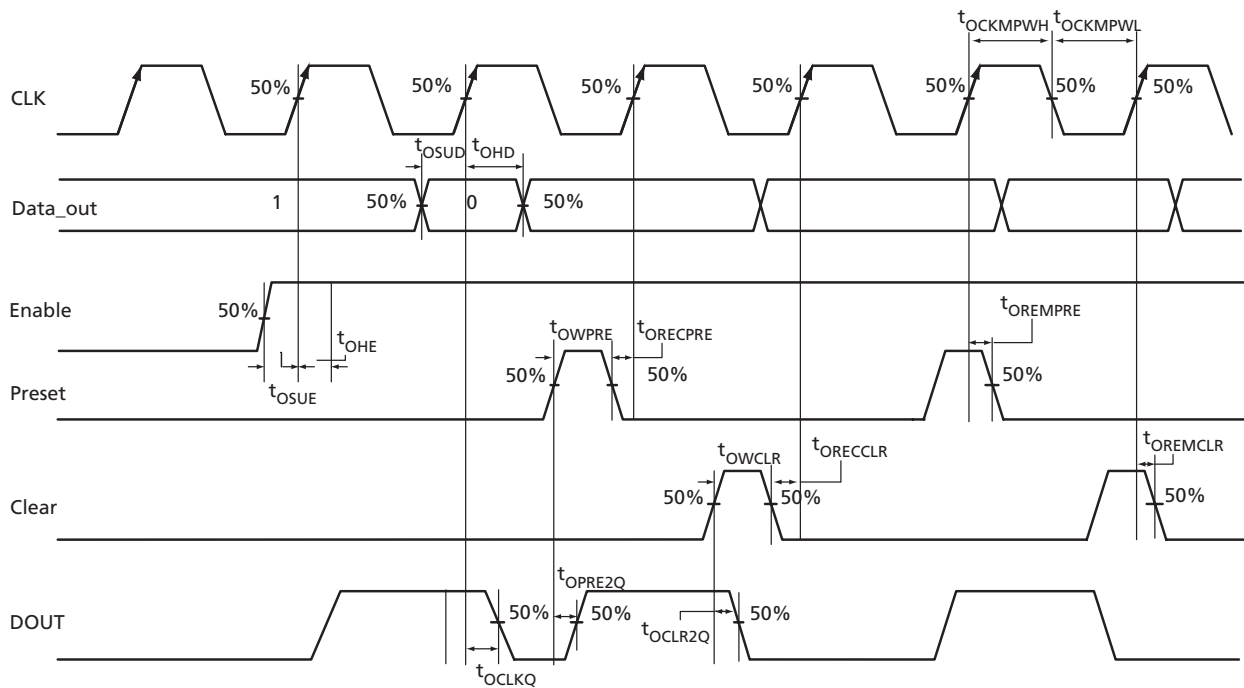

Figure 2-17 • Output Register Timing Diagram

Timing Characteristics

Table 2-90 • Output Data Register Propagation Delays
Commercial-Case Conditions: $T_J = 70^\circ\text{C}$, Worst-Case $V_{CC} = 1.425\text{ V}$

Parameter	Description	-2	-1	Std.	-F	Units
t_{OCLKQ}	Clock-to-Q of the Output Data Register	0.59	0.67	0.79	0.95	ns
t_{OSUD}	Data Setup Time for the Output Data Register	0.31	0.36	0.42	0.50	ns
t_{OHD}	Data Hold Time for the Output Data Register	0.00	0.00	0.00	0.00	ns
t_{OSUE}	Enable Setup Time for the Output Data Register	0.44	0.50	0.59	0.70	ns
t_{OHE}	Enable Hold Time for the Output Data Register	0.00	0.00	0.00	0.00	ns
t_{OCLR2Q}	Asynchronous Clear-to-Q of the Output Data Register	0.80	0.91	1.07	1.29	ns
t_{OPRE2Q}	Asynchronous Preset-to-Q of the Output Data Register	0.80	0.91	1.07	1.29	ns
$t_{OREMCLR}$	Asynchronous Clear Removal Time for the Output Data Register	0.00	0.00	0.00	0.00	ns
$t_{ORECCLR}$	Asynchronous Clear Recovery Time for the Output Data Register	0.22	0.25	0.30	0.36	ns
$t_{OREMPRE}$	Asynchronous Preset Removal Time for the Output Data Register	0.00	0.00	0.00	0.00	ns
$t_{ORECPRE}$	Asynchronous Preset Recovery Time for the Output Data Register	0.22	0.25	0.30	0.36	ns
t_{OWCLR}	Asynchronous Clear Minimum Pulse Width for the Output Data Register	0.22	0.25	0.30	0.36	ns
t_{OWPRE}	Asynchronous Preset Minimum Pulse Width for the Output Data Register	0.22	0.25	0.30	0.36	ns
$t_{OCKMPWH}$	Clock Minimum Pulse Width HIGH for the Output Data Register	0.36	0.41	0.48	0.57	ns
$t_{OCKMPWL}$	Clock Minimum Pulse Width LOW for the Output Data Register	0.32	0.37	0.43	0.52	ns

Note: For specific junction temperature and voltage supply levels, refer to Table 2-6 on page 2-6 for derating values.

Output Enable Register

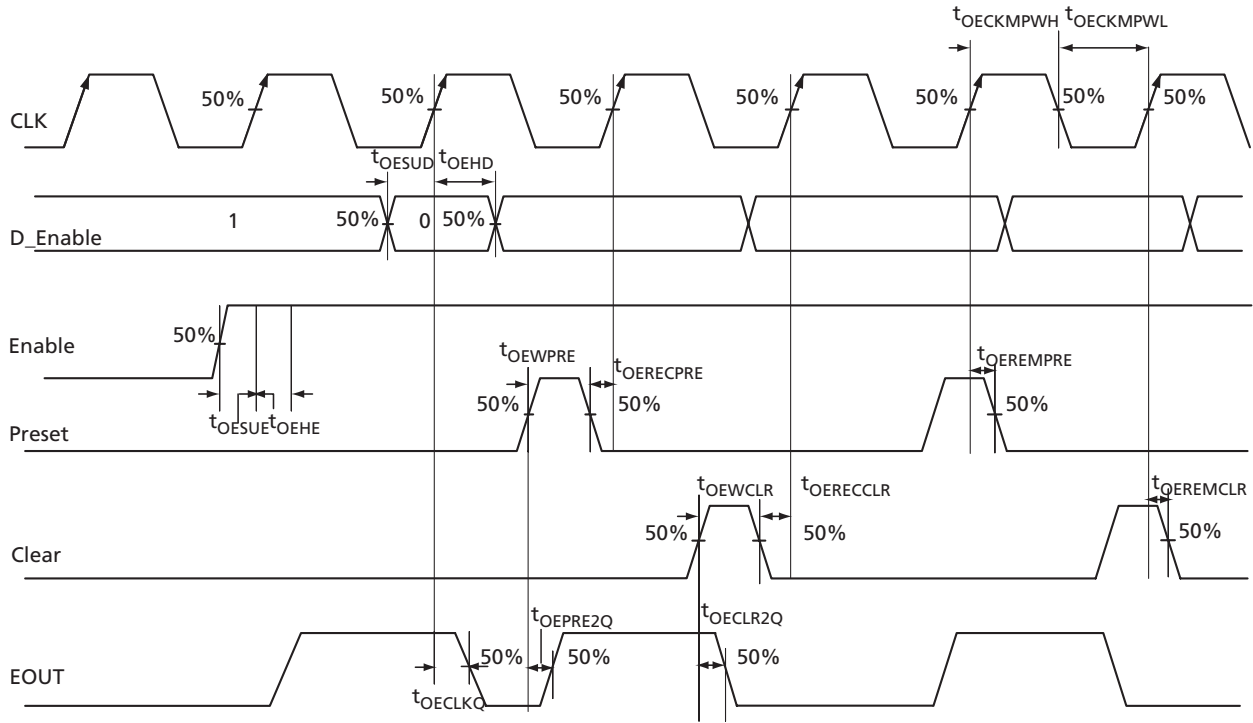

Figure 2-18 • Output Enable Register Timing Diagram

Timing Characteristics

Table 2-91 • Output Enable Register Propagation Delays
Commercial-Case Conditions: $T_J = 70^\circ\text{C}$, Worst-Case $V_{CC} = 1.425\text{ V}$

Parameter	Description	-2	-1	Std.	-F	Units
t_{OECLKQ}	Clock-to-Q of the Output Enable Register	0.59	0.67	0.79	0.95	ns
t_{OESUD}	Data Setup Time for the Output Enable Register	0.31	0.36	0.42	0.50	ns
t_{OEHD}	Data Hold Time for the Output Enable Register	0.00	0.00	0.00	0.00	ns
t_{OESUE}	Enable Setup Time for the Output Enable Register	0.44	0.50	0.58	0.70	ns
t_{OEHE}	Enable Hold Time for the Output Enable Register	0.00	0.00	0.00	0.00	ns
$t_{OECLR2Q}$	Asynchronous Clear-to-Q of the Output Enable Register	0.67	0.76	0.89	1.07	ns
$t_{OEPRE2Q}$	Asynchronous Preset-to-Q of the Output Enable Register	0.67	0.76	0.89	1.07	ns
$t_{OEREMCLR}$	Asynchronous Clear Removal Time for the Output Enable Register	0.00	0.00	0.00	0.00	ns
$t_{OERECCLR}$	Asynchronous Clear Recovery Time for the Output Enable Register	0.22	0.25	0.30	0.36	ns
$t_{OEREMPRE}$	Asynchronous Preset Removal Time for the Output Enable Register	0.00	0.00	0.00	0.00	ns
$t_{OERECPRE}$	Asynchronous Preset Recovery Time for the Output Enable Register	0.22	0.25	0.30	0.36	ns
$t_{OEWCCLR}$	Asynchronous Clear Minimum Pulse Width for the Output Enable Register	0.22	0.25	0.30	0.36	ns
t_{OEWPRE}	Asynchronous Preset Minimum Pulse Width for the Output Enable Register	0.22	0.25	0.30	0.36	ns
$t_{OECKMPWH}$	Clock Minimum Pulse Width HIGH for the Output Enable Register	0.36	0.41	0.48	0.57	ns
$t_{OECKMPWL}$	Clock Minimum Pulse Width LOW for the Output Enable Register	0.32	0.37	0.43	0.52	ns

Note: For specific junction temperature and voltage supply levels, refer to [Table 2-6 on page 2-6](#) for derating values.

DDR Module Specifications

Input DDR Module

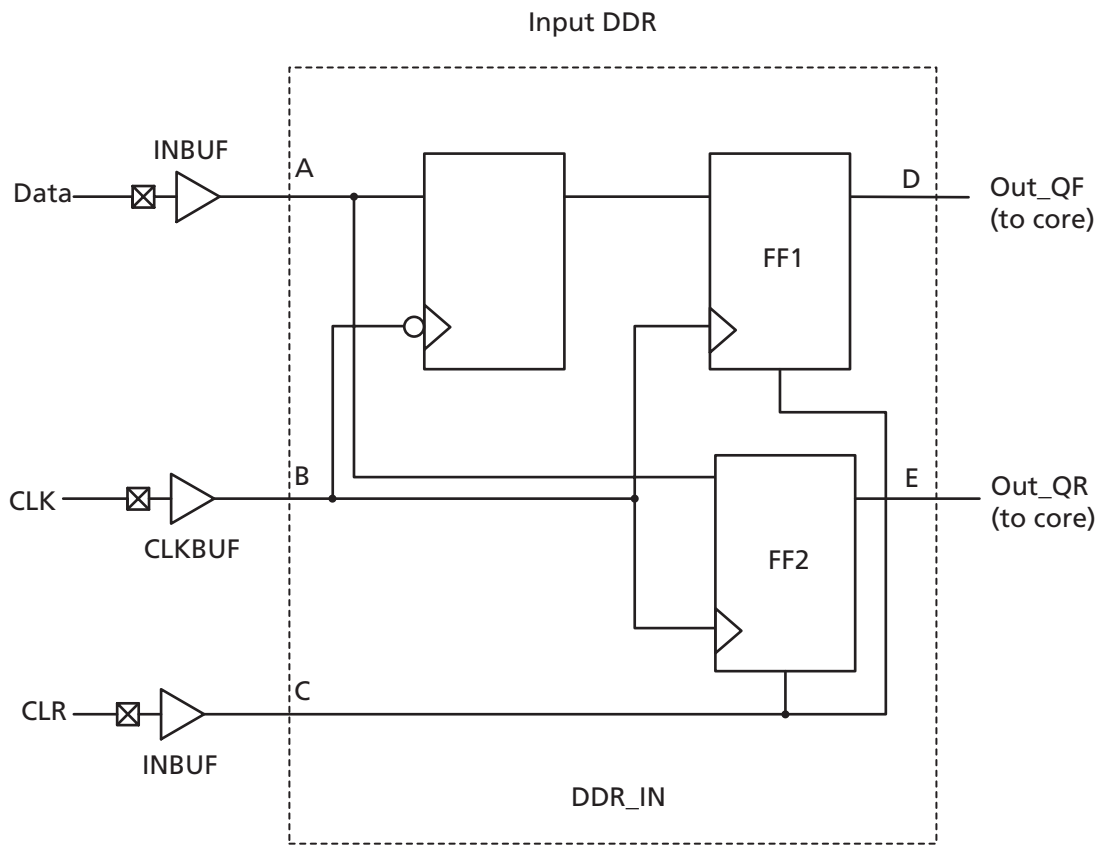
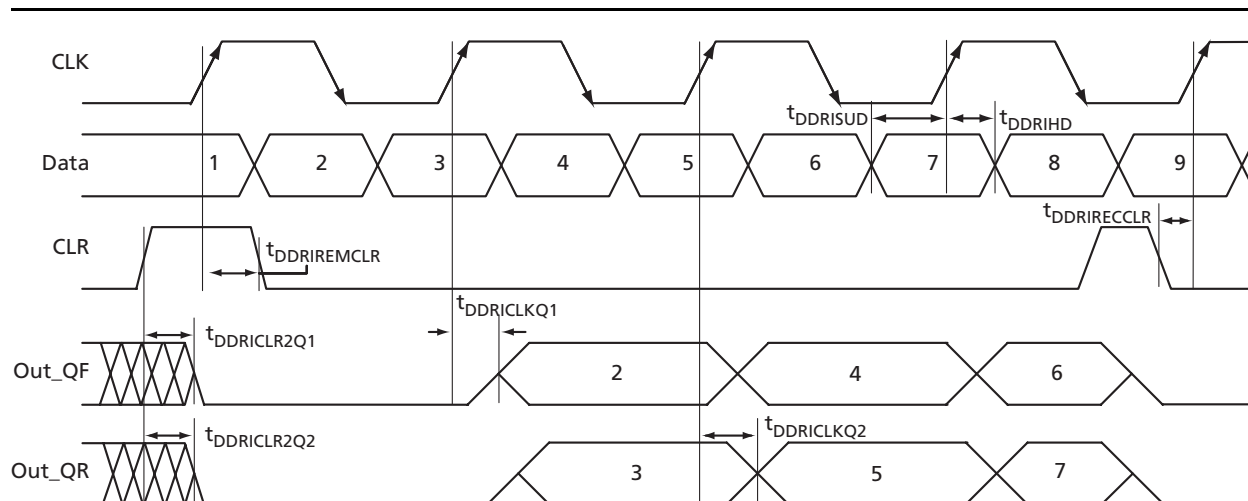

Figure 2-19 • Input DDR Timing Model

Table 2-92 • Parameter Definitions

Parameter Name	Parameter Definition	Measuring Nodes (from, to)
$t_{DDRICKQ1}$	Clock-to-Out Out_QR	B, D
$t_{DDRICKQ2}$	Clock-to-Out Out_QF	B, E
$t_{DDRISUD}$	Data Setup Time of DDR input	A, B
t_{DDRIHD}	Data Hold Time of DDR input	A, B
$t_{DDRICLR2Q1}$	Clear-to-Out Out_QR	C, D
$t_{DDRICLR2Q2}$	Clear-to-Out Out_QF	C, E
$t_{DDRIREMCLR}$	Clear Removal	C, B
$t_{DDRIRECCLR}$	Clear Recovery	C, B

Figure 2-20 • Input DDR Timing Diagram

Timing Characteristics

Table 2-93 • Input DDR Propagation Delays

 Commercial-Case Conditions: $T_J = 70^\circ\text{C}$, Worst Case $V_{CC} = 1.425\text{ V}$

Parameter	Description	-2	-1	Std.	-F	Units
t_{DDRICKQ1}	Clock-to-Out Out_QR for Input DDR	0.27	0.31	0.37	0.44	ns
t_{DDRICKQ2}	Clock-to-Out Out_QF for Input DDR	0.39	0.44	0.52	0.62	ns
t_{DDRISUD}	Data Setup for Input DDR (Fall)	0.25	0.28	0.33	0.40	ns
	Data Setup for Input DDR (Rise)	0.25	0.28	0.33	0.40	ns
t_{DDRIHD}	Data Hold for Input DDR (Fall)	0.00	0.00	0.00	0.00	ns
	Data Hold for Input DDR (Rise)	0.00	0.00	0.00	0.00	ns
$t_{\text{DDRICLR2Q1}}$	Asynchronous Clear-to-Out Out_QR for Input DDR	0.46	0.53	0.62	0.74	ns
$t_{\text{DDRICLR2Q2}}$	Asynchronous Clear-to-Out Out_QF for Input DDR	0.57	0.65	0.76	0.92	ns
$t_{\text{DDRIREMCLR}}$	Asynchronous Clear Removal time for Input DDR	0.00	0.00	0.00	0.00	ns
$t_{\text{DDRIRECCLR}}$	Asynchronous Clear Recovery time for Input DDR	0.22	0.25	0.30	0.36	ns
t_{DDRIWCLR}	Asynchronous Clear Minimum Pulse Width for Input DDR	0.22	0.25	0.30	0.36	ns
$t_{\text{DDRICKMPWH}}$	Clock Minimum Pulse Width High for Input DDR	0.36	0.41	0.48	0.57	ns
$t_{\text{DDRICKMPWL}}$	Clock Minimum Pulse Width Low for Input DDR	0.32	0.37	0.43	0.52	ns
F_{DDRIMAX}	Maximum Frequency for Input DDR					MHz

Note: For specific junction temperature and voltage-supply levels, refer to [Table 2-6 on page 2-6](#) for derating values.

Output DDR Module

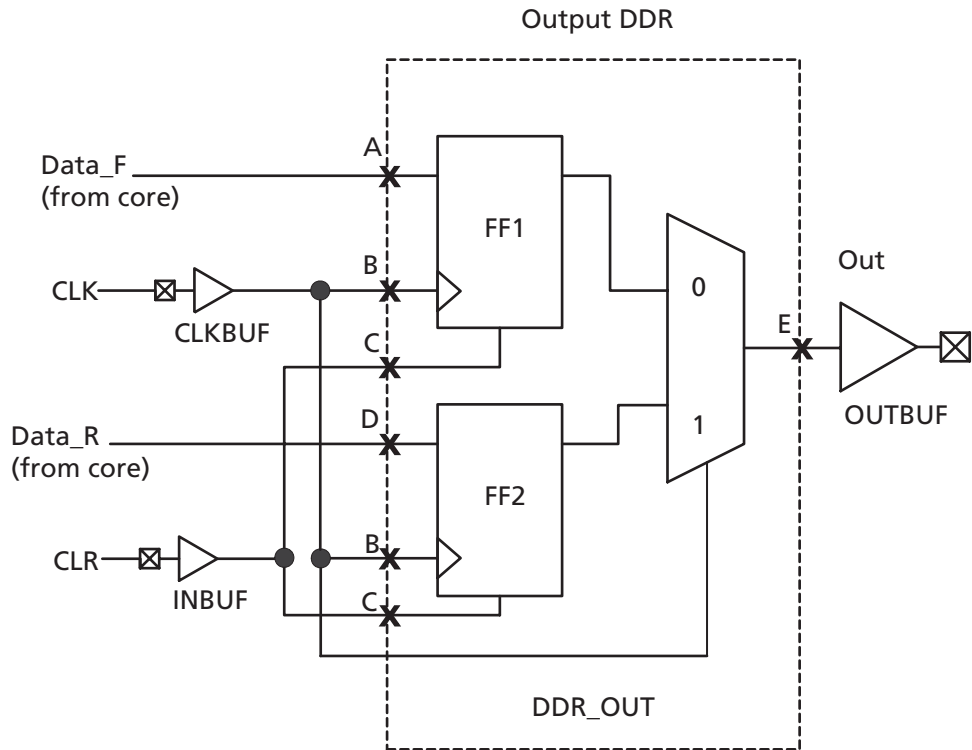
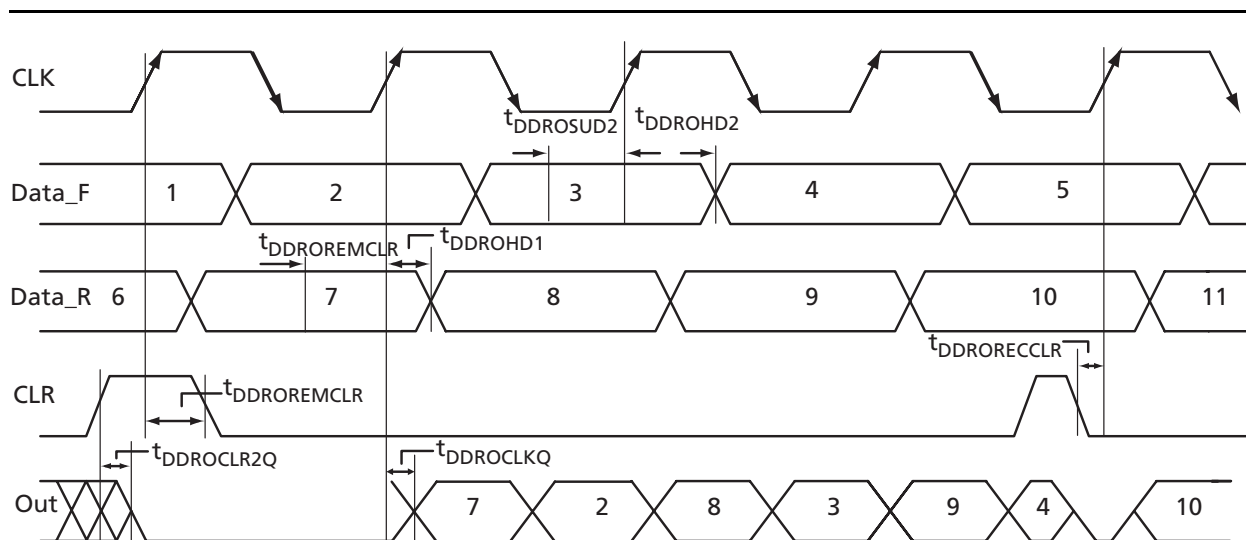

Figure 2-21 • Output DDR Timing Model

Table 2-94 • Parameter Definitions

Parameter Name	Parameter Definition	Measuring Nodes (from, to)
$t_{DDROCLKQ}$	Clock-to-Out	B, E
$t_{DDROCLR2Q}$	Asynchronous Clear-to-Out	C, E
$t_{DDROREMCLR}$	Clear Removal	C, B
$t_{DDRORECLR}$	Clear Recovery	C, B
$t_{DDROSUD1}$	Data Setup Data_F	A, B
$t_{DDROSUD2}$	Data Setup Data_R	D, B
$t_{DDROHD1}$	Data Hold Data_F	A, B
$t_{DDROHD2}$	Data Hold Data_R	D, B

Figure 2-22 • Output DDR Timing Diagram

Timing Characteristics

Table 2-95 • Output DDR Propagation Delays

 Commercial-Case Conditions: $T_J = 70^\circ\text{C}$, Worst-Case $V_{CC} = 1.425\text{ V}$

Parameter	Description	-2	-1	Std.	-F	Units
$t_{DDROCLKQ}$	Clock-to-Out of DDR for Output DDR	0.70	0.80	0.94	1.13	ns
$t_{DDROSUD1}$	Data_F Data Setup for Output DDR	0.38	0.43	0.51	0.61	ns
$t_{DDROSUD2}$	Data_R Data Setup for Output DDR	0.38	0.43	0.51	0.61	ns
$t_{DDROHD1}$	Data_F Data Hold for Output DDR	0.00	0.00	0.00	0.00	ns
$t_{DDROHD2}$	Data_R Data Hold for Output DDR	0.00	0.00	0.00	0.00	ns
$t_{DDROCLR2Q}$	Asynchronous Clear-to-Out for Output DDR	0.80	0.91	1.07	1.29	ns
$t_{DDROEMCLR}$	Asynchronous Clear Removal Time for Output DDR	0.00	0.00	0.00	0.00	ns
$t_{DDROECCLR}$	Asynchronous Clear Recovery Time for Output DDR	0.22	0.25	0.30	0.36	ns
$t_{DDROWCLR1}$	Asynchronous Clear Minimum Pulse Width for Output DDR	0.22	0.25	0.30	0.36	ns
$t_{DDROCKMPWH}$	Clock Minimum Pulse Width HIGH for the Output DDR	0.36	0.41	0.48	0.57	ns
$t_{DDROCKMPWL}$	Clock Minimum Pulse Width LOW for the Output DDR	0.32	0.37	0.43	0.52	ns
F_{DDOMAX}	Maximum Frequency for the Output DDR	TBD	TBD	TBD	TBD	MHz

Note: For specific junction temperature and voltage supply levels, refer to [Table 2-6 on page 2-6](#) for derating values.

VersaTile Characteristics

VersaTile Specifications as a Combinatorial Module

The ProASIC3 library offers all combinations of LUT-3 combinatorial functions. In this section, timing characteristics are presented for a sample of the library. For more details, refer to the *Fusion, IGLOO[®]le, and ProASIC3/E Macro Library Guide*.

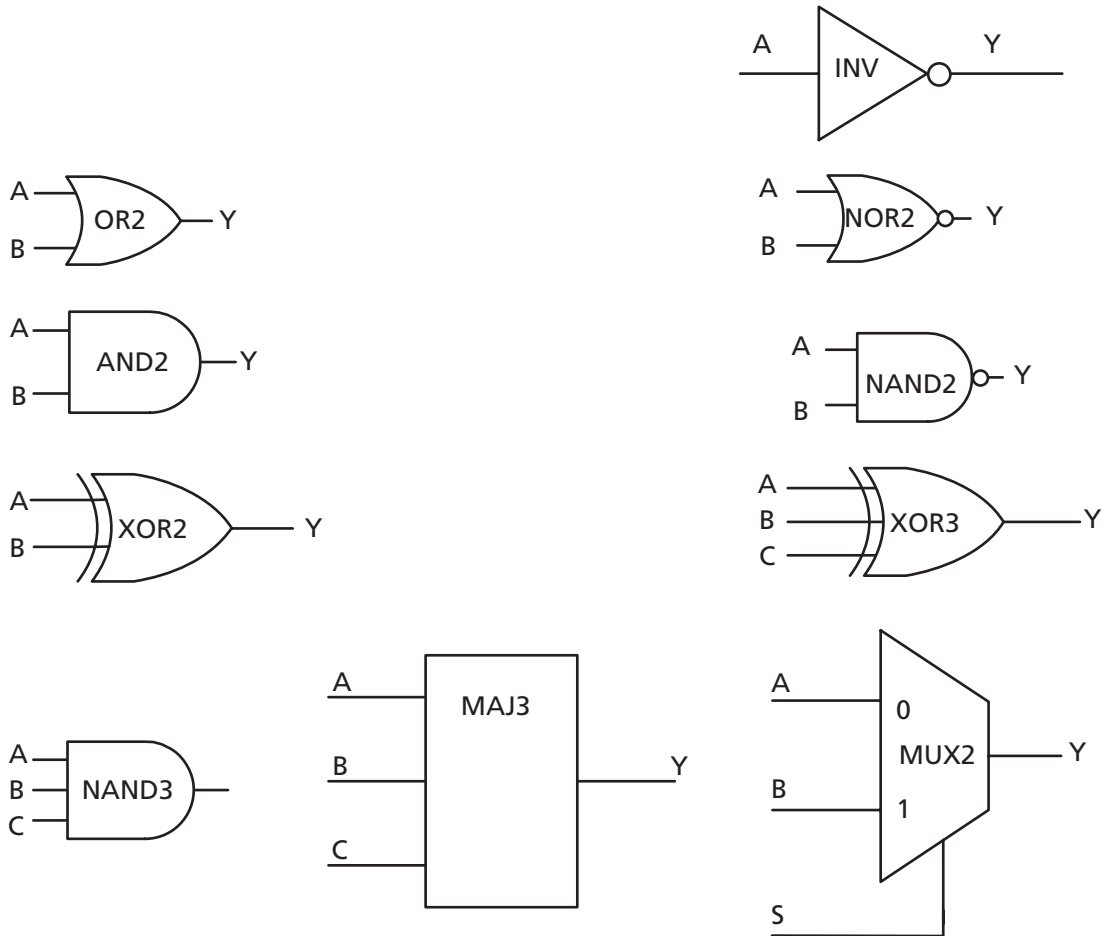

Figure 2-23 • Sample of Combinatorial Cells

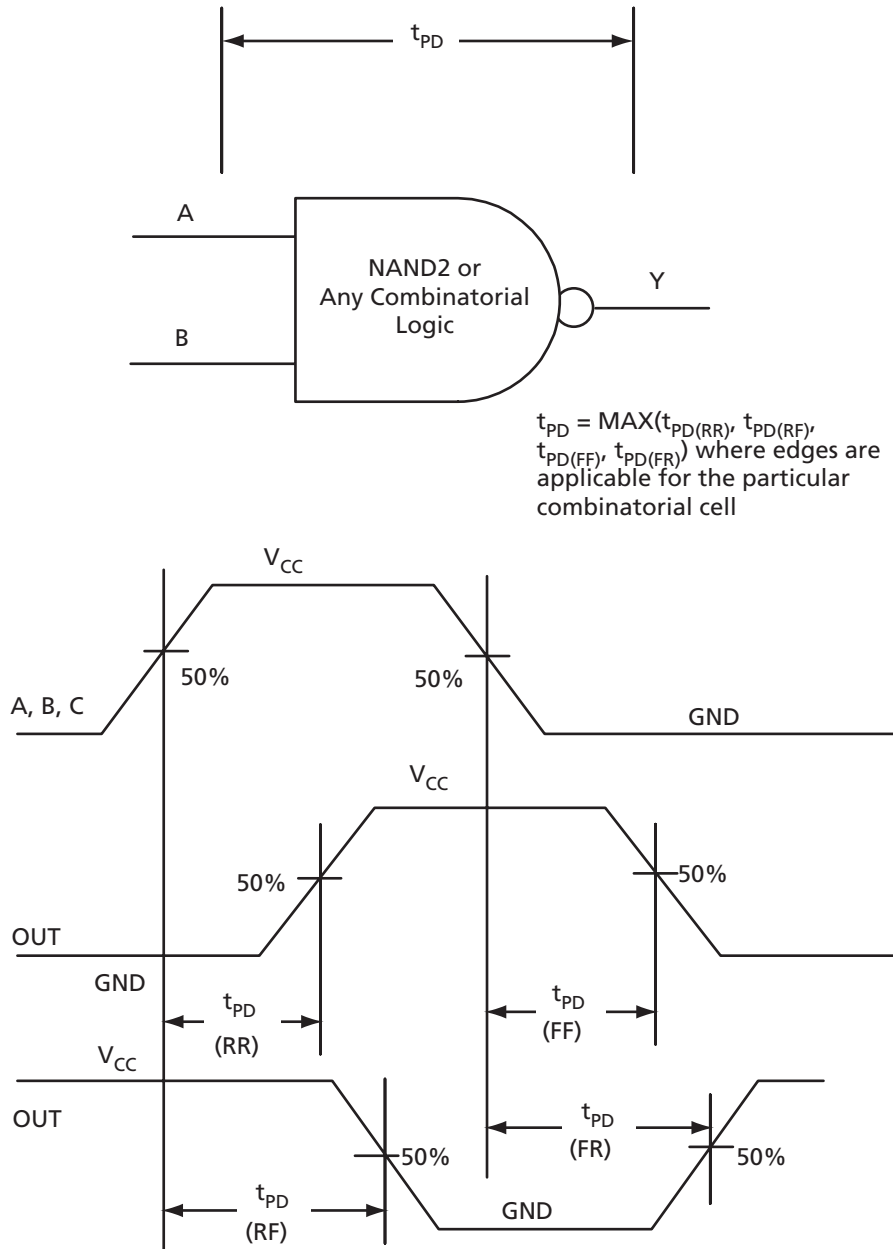

Figure 2-24 • Timing Model and Waveforms

Timing Characteristics

Table 2-96 • Combinatorial Cell Propagation Delays
 Commercial-Case Conditions: $T_j = 70^\circ\text{C}$, Worst-Case $V_{CC} = 1.425\text{ V}$

Combinatorial Cell	Equation	Parameter	-2	-1	Std.	-F	Units
INV	$Y = !A$	t_{PD}	0.40	0.46	0.54	0.65	ns
AND2	$Y = A \cdot B$	t_{PD}	0.47	0.54	0.63	0.76	ns
NAND2	$Y = !(A \cdot B)$	t_{PD}	0.47	0.54	0.63	0.76	ns
OR2	$Y = A + B$	t_{PD}	0.49	0.55	0.65	0.78	ns
NOR2	$Y = !(A + B)$	t_{PD}	0.49	0.55	0.65	0.78	ns
XOR2	$Y = A \oplus B$	t_{PD}	0.74	0.84	0.99	1.19	ns
MAJ3	$Y = \text{MAJ}(A, B, C)$	t_{PD}	0.70	0.79	0.93	1.12	ns
XOR3	$Y = A \oplus B \oplus C$	t_{PD}	0.87	1.00	1.17	1.41	ns
MUX2	$Y = A !S + B S$	t_{PD}	0.51	0.58	0.68	0.81	ns
AND3	$Y = A \cdot B \cdot C$	t_{PD}	0.56	0.64	0.75	0.90	ns

Note: For specific junction temperature and voltage supply levels, refer to [Table 2-6 on page 2-6](#) for derating values.

VersaTile Specifications as a Sequential Module

The ProASIC3 library offers a wide variety of sequential cells, including flip-flops and latches. Each has a data input and optional enable, clear, or preset. In this section, timing characteristics are presented for a representative sample from the library. For more details, refer to the *Fusion, IGLOOe, and ProASIC3IE Macro Library Guide*.

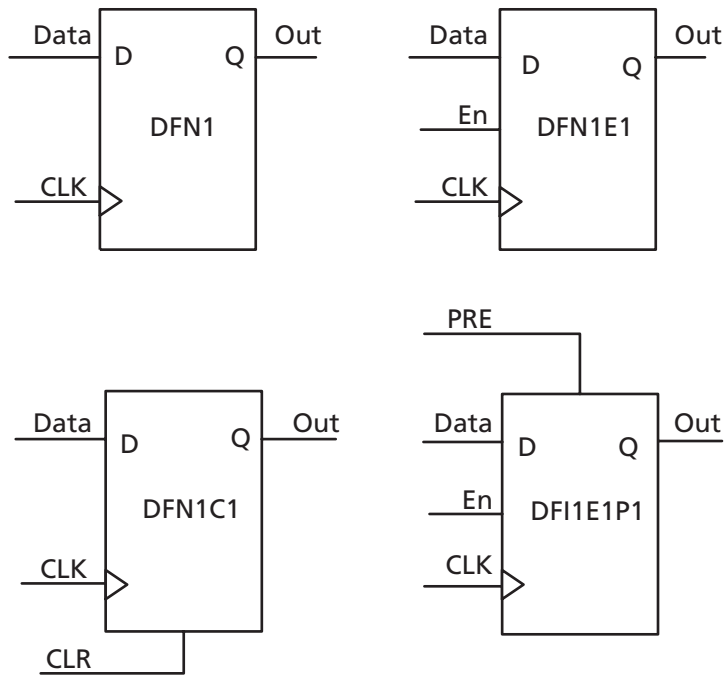
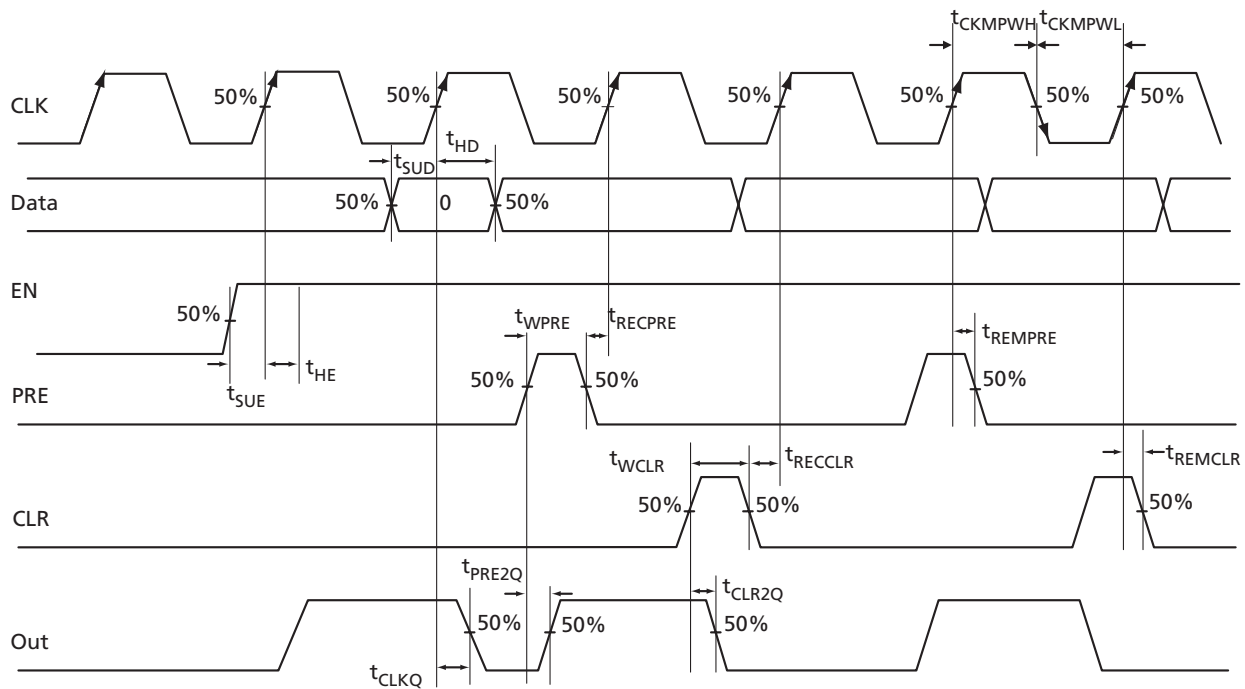

Figure 2-25 • Sample of Sequential Cells

Figure 2-26 • Timing Model and Waveforms

Timing Characteristics

Table 2-97 • Register Delays

 Commercial-Case Conditions: $T_J = 70^\circ\text{C}$, Worst-Case $V_{CC} = 1.425\text{ V}$

Parameter	Description	-2	-1	Std.	-F	Units
t_{CLKQ}	Clock-to-Q of the Core Register	0.55	0.63	0.74	0.89	ns
t_{SUD}	Data Setup Time for the Core Register	0.43	0.49	0.57	0.69	ns
t_{HD}	Data Hold Time for the Core Register	0.00	0.00	0.00	0.00	ns
t_{SUE}	Enable Setup Time for the Core Register	0.45	0.52	0.61	0.73	ns
t_{HE}	Enable Hold Time for the Core Register	0.00	0.00	0.00	0.00	ns
t_{CLR2Q}	Asynchronous Clear-to-Q of the Core Register	0.40	0.45	0.53	0.64	ns
t_{PRE2Q}	Asynchronous Preset-to-Q of the Core Register	0.40	0.45	0.53	0.64	ns
t_{REMCLR}	Asynchronous Clear Removal Time for the Core Register	0.00	0.00	0.00	0.00	ns
t_{RECLR}	Asynchronous Clear Recovery Time for the Core Register	0.22	0.25	0.30	0.36	ns
t_{REMPRE}	Asynchronous Preset Removal Time for the Core Register	0.00	0.00	0.00	0.00	ns
t_{RECPRE}	Asynchronous Preset Recovery Time for the Core Register	0.22	0.25	0.30	0.36	ns
t_{WCLR}	Asynchronous Clear Minimum Pulse Width for the Core Register	0.22	0.25	0.30	0.36	ns
t_{WPRE}	Asynchronous Preset Minimum Pulse Width for the Core Register	0.22	0.25	0.30	0.36	ns
t_{CKMPWH}	Clock Minimum Pulse Width HIGH for the Core Register	0.32	0.37	0.43	0.52	ns
t_{CKMPWL}	Clock Minimum Pulse Width LOW for the Core Register	0.36	0.41	0.48	0.57	ns

Note: For specific junction temperature and voltage supply levels, refer to Table 2-6 on page 2-6 for derating values.

Global Resource Characteristics

A3P250 Clock Tree Topology

Clock delays are device-specific. Figure 2-27 is an example of a global tree used for clock routing. The global tree presented in Figure 2-27 is driven by a CCC located on the west side of the A3P250 device. It is used to drive all D-flip-flops in the device.

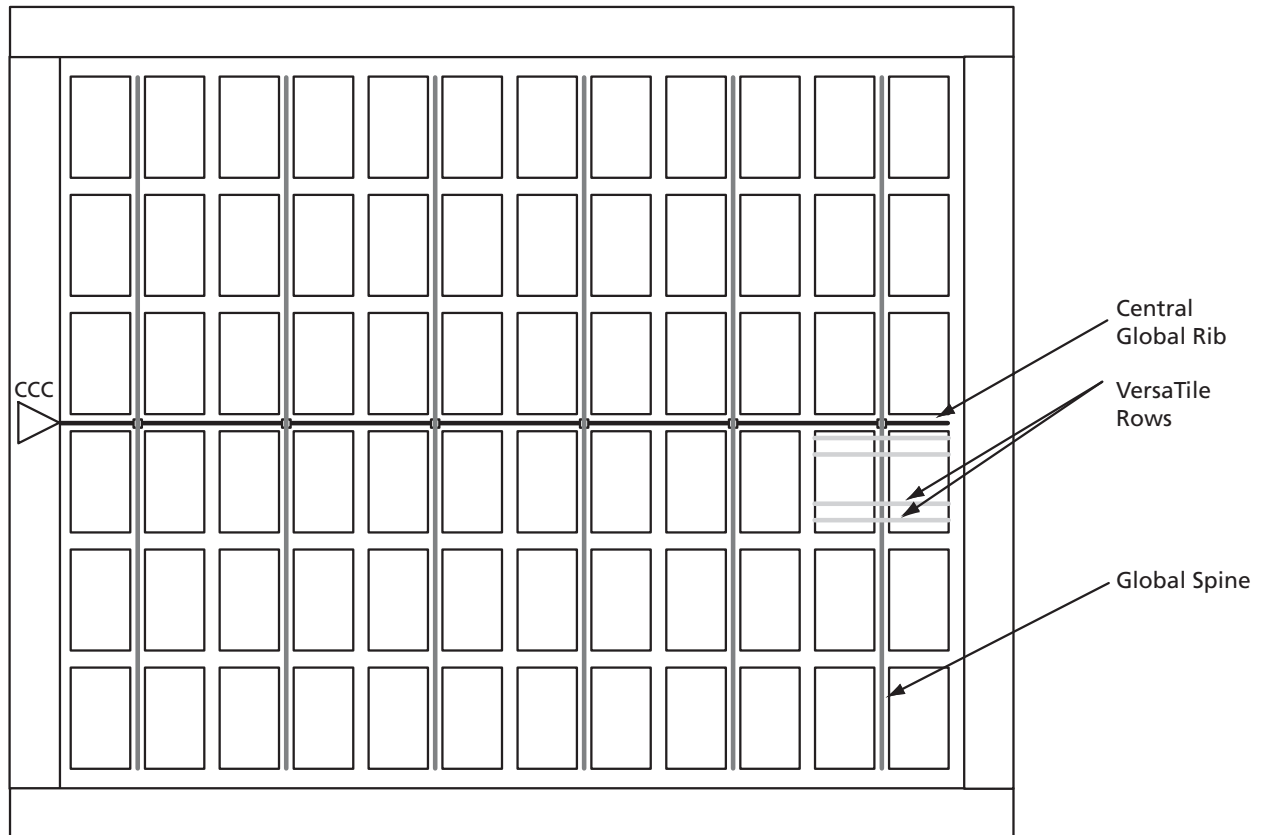

Figure 2-27 • Example of Global Tree Use in an A3P250 Device for Clock Routing

Global Tree Timing Characteristics

Global clock delays include the central rib delay, the spine delay, and the row delay. Delays do not include I/O input buffer clock delays, as these are I/O standard-dependent, and the clock may be driven and conditioned internally by the CCC module. For more details on clock conditioning capabilities, refer to the "Clock Conditioning Circuits" section on page 2-83. Table 2-99 to Table 2-105 on page 2-82 present minimum and maximum global clock delays within each device. Minimum and maximum delays are measured with minimum and maximum loading.

Timing Characteristics

Table 2-98 • A3P015 Global Resource
Commercial-Case Conditions: $T_J = 70^\circ\text{C}$, $V_{CC} = 1.425\text{ V}$

Parameter	Description	-2		-1		Std.		-F		Units
		Min. ¹	Max. ²	Min. ¹	Max. ²	Min. ¹	Max. ²	Min. ¹	Max. ²	
t _{RCKL}	Input LOW Delay for Global Clock	0.66	0.81	0.75	0.92	0.88	1.08	1.06	1.30	ns
t _{RCKH}	Input HIGH Delay for Global Clock	0.67	0.84	0.76	0.96	0.89	1.13	1.07	1.36	ns
t _{RCKMPWH}	Minimum Pulse Width HIGH for Global Clock									ns
t _{RCKMPWL}	Minimum Pulse Width LOW for Global Clock									ns
t _{RCKSW}	Maximum Skew for Global Clock		0.18		0.21		0.25		0.30	ns
F _{RMAX}	Maximum Frequency for Global Clock									MHz

Notes:

1. Value reflects minimum load. The delay is measured from the CCC output to the clock pin of a sequential element, located in a lightly loaded row (single element is connected to the global net).
2. Value reflects maximum load. The delay is measured on the clock pin of the farthest sequential element, located in a fully loaded row (all available flip-flops are connected to the global net in the row).
3. For specific junction temperature and voltage-supply levels, refer to Table 2-6 on page 2-6 for derating values.

Table 2-99 • A3P030 Global Resource
Commercial-Case Conditions: $T_J = 70^\circ\text{C}$, $V_{CC} = 1.425\text{ V}$

Parameter	Description	-2		-1		Std.		-F		Units
		Min. ¹	Max. ²	Min. ¹	Max. ²	Min. ¹	Max. ²	Min. ¹	Max. ²	
t _{RCKL}	Input LOW Delay for Global Clock	0.67	0.81	0.76	0.92	0.89	1.09	1.07	1.31	ns
t _{RCKH}	Input HIGH Delay for Global Clock	0.68	0.85	0.77	0.97	0.91	1.14	1.09	1.37	ns
t _{RCKMPWH}	Minimum Pulse Width HIGH for Global Clock									ns
t _{RCKMPWL}	Minimum Pulse Width LOW for Global Clock									ns
t _{RCKSW}	Maximum Skew for Global Clock		0.18		0.21		0.24		0.29	ns
F _{RMAX}	Maximum Frequency for Global Clock									MHz

Notes:

1. Value reflects minimum load. The delay is measured from the CCC output to the clock pin of a sequential element, located in a lightly loaded row (single element is connected to the global net).
2. Value reflects maximum load. The delay is measured on the clock pin of the farthest sequential element, located in a fully loaded row (all available flip-flops are connected to the global net in the row).
3. For specific junction temperature and voltage supply levels, refer to Table 2-6 on page 2-6 for derating values.

Table 2-100 • A3P060 Global Resource
 Commercial-Case Conditions: $T_J = 70^\circ\text{C}$, $V_{CC} = 1.425\text{ V}$

Parameter	Description	-2		-1		Std.		-F		Units
		Min. ¹	Max. ²	Min. ¹	Max. ²	Min. ¹	Max. ²	Min. ¹	Max. ²	
t_{RCKL}	Input LOW Delay for Global Clock	0.71	0.93	0.81	1.05	0.95	1.24	1.14	1.49	ns
t_{RCKH}	Input HIGH Delay for Global Clock	0.70	0.96	0.80	1.09	0.94	1.28	1.13	1.54	ns
$t_{RCKMPWH}$	Minimum Pulse Width HIGH for Global Clock									ns
$t_{RCKMPWL}$	Minimum Pulse Width LOW for Global Clock									ns
t_{RCKSW}	Maximum Skew for Global Clock		0.26		0.29		0.34		0.41	ns
F_{RMAX}	Maximum Frequency for Global Clock									MHz

Notes:

1. Value reflects minimum load. The delay is measured from the CCC output to the clock pin of a sequential element, located in a lightly loaded row (single element is connected to the global net).
2. Value reflects maximum load. The delay is measured on the clock pin of the farthest sequential element, located in a fully loaded row (all available flip-flops are connected to the global net in the row).
3. For specific junction temperature and voltage supply levels, refer to [Table 2-6 on page 2-6](#) for derating values.

Table 2-101 • A3P125 Global Resource
 Commercial-Case Conditions: $T_J = 70^\circ\text{C}$, $V_{CC} = 1.425\text{ V}$

Parameter	Description	-2		-1		Std.		-F		Units
		Min. ¹	Max. ²	Min. ¹	Max. ²	Min. ¹	Max. ²	Min. ¹	Max. ²	
t_{RCKL}	Input LOW Delay for Global Clock	0.77	0.99	0.87	1.12	1.03	1.32	1.24	1.58	ns
t_{RCKH}	Input HIGH Delay for Global Clock	0.76	1.02	0.87	1.16	1.02	1.37	1.23	1.64	ns
$t_{RCKMPWH}$	Minimum Pulse Width HIGH for Global Clock									ns
$t_{RCKMPWL}$	Minimum Pulse Width LOW for Global Clock									ns
t_{RCKSW}	Maximum Skew for Global Clock		0.26		0.29		0.34		0.41	ns
F_{RMAX}	Maximum Frequency for Global Clock									MHz

Notes:

1. Value reflects minimum load. The delay is measured from the CCC output to the clock pin of a sequential element, located in a lightly loaded row (single element is connected to the global net).
2. Value reflects maximum load. The delay is measured on the clock pin of the farthest sequential element, located in a fully loaded row (all available flip-flops are connected to the global net in the row).
3. For specific junction temperature and voltage supply levels, refer to [Table 2-6 on page 2-6](#) for derating values.

Table 2-102 • A3P250 Global Resource
 Commercial-Case Conditions: $T_J = 70^\circ\text{C}$, $V_{CC} = 1.425\text{ V}$

Parameter	Description	-2		-1		Std.		-F		Units
		Min. ¹	Max. ²	Min. ¹	Max. ²	Min. ¹	Max. ²	Min. ¹	Max. ²	
t_{RCKL}	Input LOW Delay for Global Clock	0.80	1.01	0.91	1.15	1.07	1.36	1.28	1.63	ns
t_{RCKH}	Input HIGH Delay for Global Clock	0.78	1.04	0.89	1.18	1.04	1.39	1.25	1.66	ns
$t_{RCKMPWH}$	Minimum Pulse Width HIGH for Global Clock									ns
$t_{RCKMPWL}$	Minimum Pulse Width LOW for Global Clock									ns
t_{RCKSW}	Maximum Skew for Global Clock		0.26		0.29		0.34		0.41	ns
F_{RMAX}	Maximum Frequency for Global Clock									MHz

Notes:

1. Value reflects minimum load. The delay is measured from the CCC output to the clock pin of a sequential element, located in a lightly loaded row (single element is connected to the global net).
2. Value reflects maximum load. The delay is measured on the clock pin of the farthest sequential element, located in a fully loaded row (all available flip-flops are connected to the global net in the row).
3. For specific junction temperature and voltage supply levels, refer to [Table 2-6 on page 2-6](#) for derating values.

Table 2-103 • A3P400 Global Resource
 Commercial-Case Conditions: $T_J = 70^\circ\text{C}$, $V_{CC} = 1.425\text{ V}$

Parameter	Description	-2		-1		Std.		-F		Units
		Min. ¹	Max. ²	Min. ¹	Max. ²	Min. ¹	Max. ²	Min. ¹	Max. ²	
t_{RCKL}	Input LOW Delay for Global Clock	0.87	1.09	0.99	1.24	1.17	1.46	1.40	1.75	ns
t_{RCKH}	Input HIGH Delay for Global Clock	0.86	1.11	0.98	1.27	1.15	1.49	1.38	1.79	ns
$t_{RCKMPWH}$	Minimum Pulse Width HIGH for Global Clock									ns
$t_{RCKMPWL}$	Minimum Pulse Width LOW for Global Clock									ns
t_{RCKSW}	Maximum Skew for Global Clock		0.26		0.29		0.34		0.41	ns
F_{RMAX}	Maximum Frequency for Global Clock									Mhz

Notes:

1. Value reflects minimum load. The delay is measured from the CCC output to the clock pin of a sequential element, located in a lightly loaded row (single element is connected to the global net).
2. Value reflects maximum load. The delay is measured on the clock pin of the farthest sequential element, located in a fully loaded row (all available flip-flops are connected to the global net in the row).
3. For specific junction temperature and voltage supply levels, refer to [Table 2-6 on page 2-6](#) for derating values.

Table 2-104 • A3P600 Global Resource
 Commercial-Case Conditions: $T_J = 70^\circ\text{C}$, $V_{CC} = 1.425\text{ V}$

Parameter	Description	-2		-1		Std.		-F		Units
		Min. ¹	Max. ²	Min. ¹	Max. ²	Min. ¹	Max. ²	Min. ¹	Max. ²	
t_{RCKL}	Input LOW Delay for Global Clock	0.87	1.09	0.99	1.24	1.17	1.46	1.40	1.75	ns
t_{RCKH}	Input HIGH Delay for Global Clock	0.86	1.11	0.98	1.27	1.15	1.49	1.38	1.79	ns
$t_{RCKMPWH}$	Minimum Pulse Width HIGH for Global Clock									ns
$t_{RCKMPWL}$	Minimum Pulse Width LOW for Global Clock									ns
t_{RCKSW}	Maximum Skew for Global Clock		0.26		0.29		0.34		0.41	ns
F_{RMAX}	Maximum Frequency for Global Clock									MHz

Notes:

1. Value reflects minimum load. The delay is measured from the CCC output to the clock pin of a sequential element, located in a lightly loaded row (single element is connected to the global net).
2. Value reflects maximum load. The delay is measured on the clock pin of the farthest sequential element, located in a fully loaded row (all available flip-flops are connected to the global net in the row).
3. For specific junction temperature and voltage supply levels, refer to [Table 2-6 on page 2-6](#) for derating values.

Table 2-105 • A3P1000 Global Resource
 Commercial-Case Conditions: $T_J = 70^\circ\text{C}$, $V_{CC} = 1.425\text{ V}$

Parameter	Description	-2		-1		Std.		-F		Units
		Min. ¹	Max. ²	Min. ¹	Max. ²	Min. ¹	Max. ²	Min. ¹	Max. ²	
t_{RCKL}	Input LOW Delay for Global Clock	0.94	1.16	1.07	1.32	1.26	1.55	1.51	1.86	ns
t_{RCKH}	Input HIGH Delay for Global Clock	0.93	1.19	1.06	1.35	1.24	1.59	1.49	1.91	ns
$t_{RCKMPWH}$	Minimum Pulse Width HIGH for Global Clock									ns
$t_{RCKMPWL}$	Minimum Pulse Width LOW for Global Clock									ns
t_{RCKSW}	Maximum Skew for Global Clock		0.26		0.29		0.35		0.41	ns
F_{RMAX}	Maximum Frequency for Global Clock									MHz

Notes:

1. Value reflects minimum load. The delay is measured from the CCC output to the clock pin of a sequential element, located in a lightly loaded row (single element is connected to the global net).
2. Value reflects maximum load. The delay is measured on the clock pin of the farthest sequential element, located in a fully loaded row (all available flip-flops are connected to the global net in the row).
3. For specific junction temperature and voltage supply levels, refer to [Table 2-6 on page 2-6](#) for derating values.

Clock Conditioning Circuits

CCC Electrical Specifications

Timing Characteristics

Table 2-106 • ProASIC3 CCC/PLL Specification

Parameter	Minimum	Typical	Maximum	Units
Clock Conditioning Circuitry Input Frequency f_{IN_CCC}	1.5		350	MHz
Clock Conditioning Circuitry Output Frequency f_{OUT_CCC}	0.75		350	MHz
Serial Clock (SCLK) for Dynamic PLL ¹			125	MHz
Delay Increments in Programmable Delay Blocks ^{2, 3}		200		ps
Number of Programmable Values in Each Programmable Delay Block			32	
Input Period Jitter			1.5	ns
CCC Output Peak-to-Peak Period Jitter F_{CCC_OUT}	Max Peak-to-Peak Period Jitter			
	1 Global Network Used		3 Global Networks Used	
0.75 MHz to 24 MHz	0.50%		0.70%	
24 MHz to 100 MHz	1.00%		1.20%	
100 MHz to 250 MHz	1.75%		2.00%	
250 MHz to 350 MHz	2.50%		5.60%	
Acquisition Time				
(A3P250 and A3P1000 only) LockControl = 0			300	μs
LockControl = 1			300	μs
(all other dies) LockControl = 0			300	μs
LockControl = 1			6.0	ms
Tracking Jitter ⁵				
(A3P250 and A3P1000 only) LockControl = 0			1.6	ns
LockControl = 1			1.6	ns
(all other dies) LockControl = 0			1.6	ns
LockControl = 1			0.8	ns
Output Duty Cycle	48.5		51.5	%
Delay Range in Block: Programmable Delay ^{1, 3}	0.6		5.56	ns
Delay Range in Block: Programmable Delay ^{2, 3}	0.025		5.56	ns
Delay Range in Block: Fixed Delay ^{2, 3}		2.2		ns

Notes:

1. Maximum value obtained for a -2 speed-grade device in worst-case commercial conditions. For specific junction temperature and voltage supply levels, refer to [Table 2-6 on page 2-6](#) for derating values.
2. This delay is a function of voltage and temperature. See [Table 2-6 on page 2-6](#) for deratings.
3. $T_J = 25^\circ\text{C}$, $V_{CC} = 1.5\text{ V}$
4. The A3P030 device does not contain a PLL.
5. Tracking jitter is defined as the variation in clock edge position of PLL outputs with reference to the PLL input clock edge. Tracking jitter does not measure the variation in PLL output period, which is covered by the period jitter parameter.

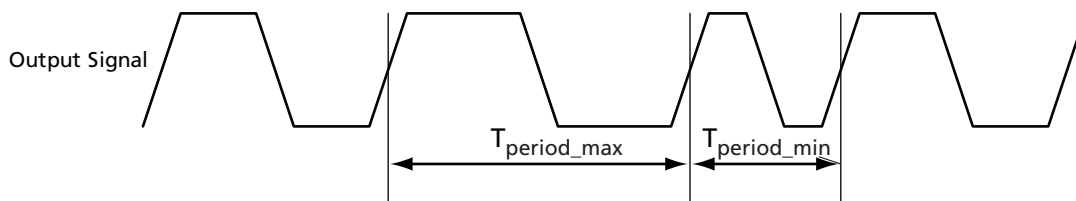

Note: Peak-to-peak jitter measurements are defined by $T_{\text{peak-to-peak}} = T_{\text{period_max}} - T_{\text{period_min}}$.

Figure 2-28 • Peak-to-Peak Jitter Definition

Embedded SRAM and FIFO Characteristics

SRAM

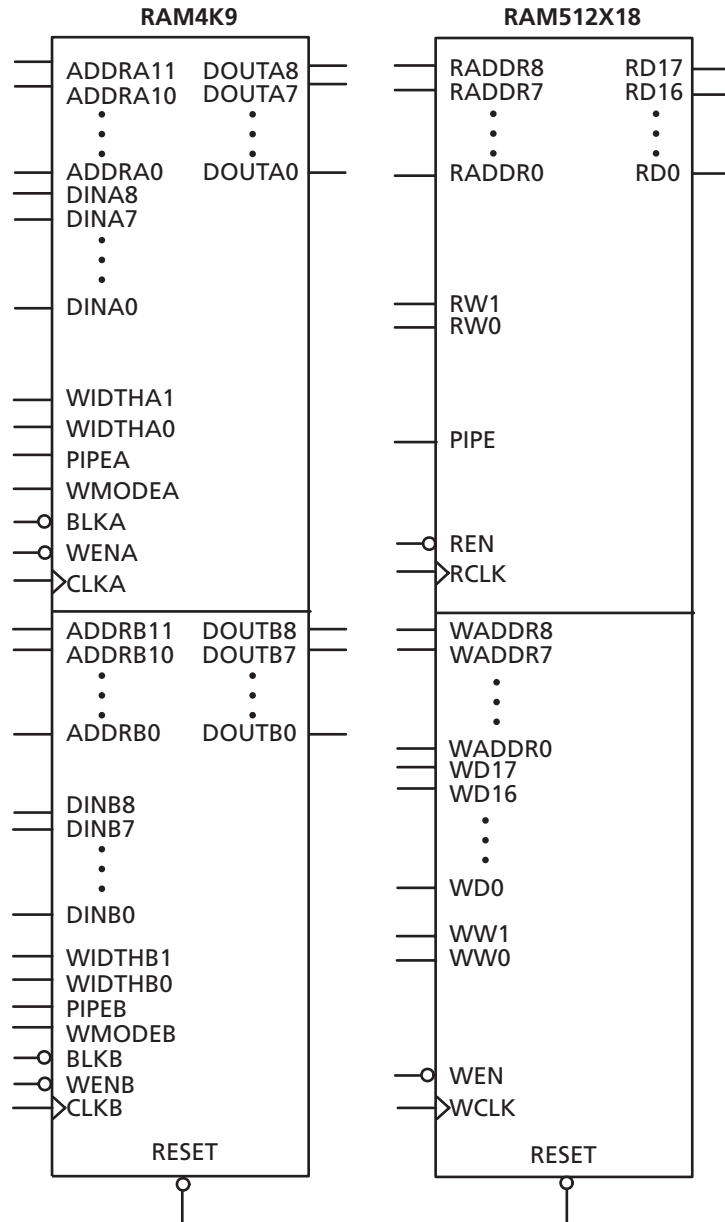

Figure 2-29 • RAM Models

Timing Waveforms

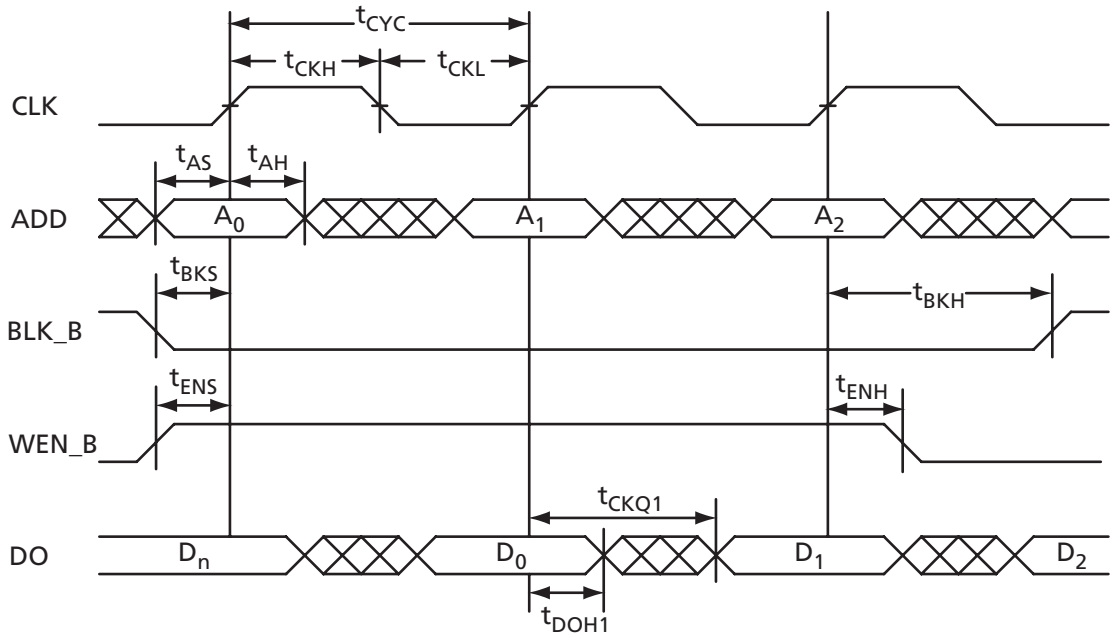

Figure 2-30 • RAM Read for Pass-Through Output

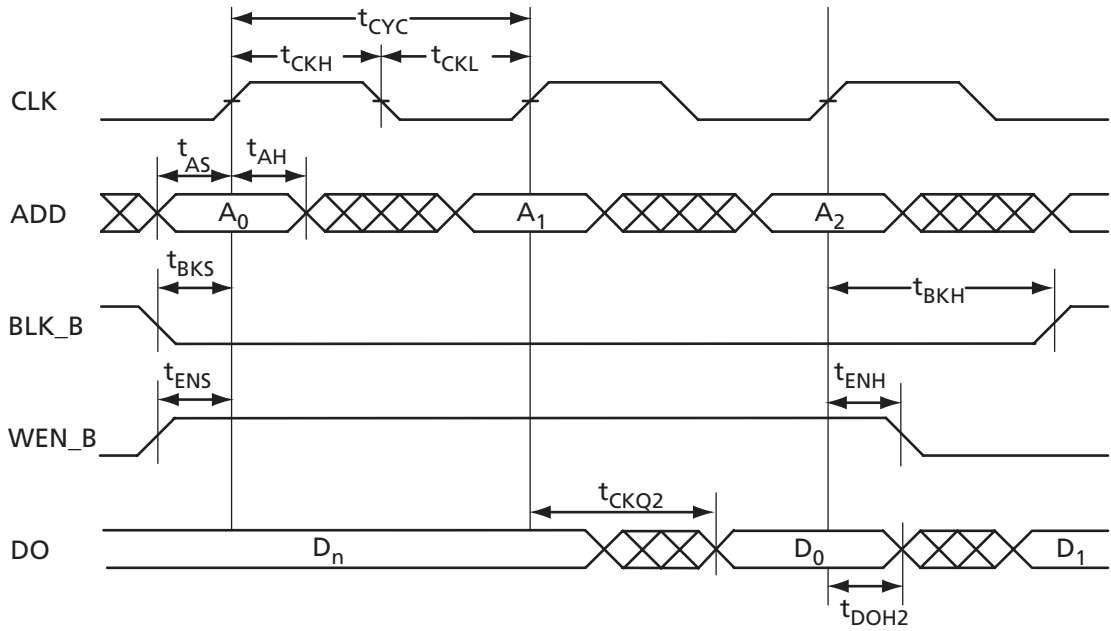

Figure 2-31 • RAM Read for Pipelined Output

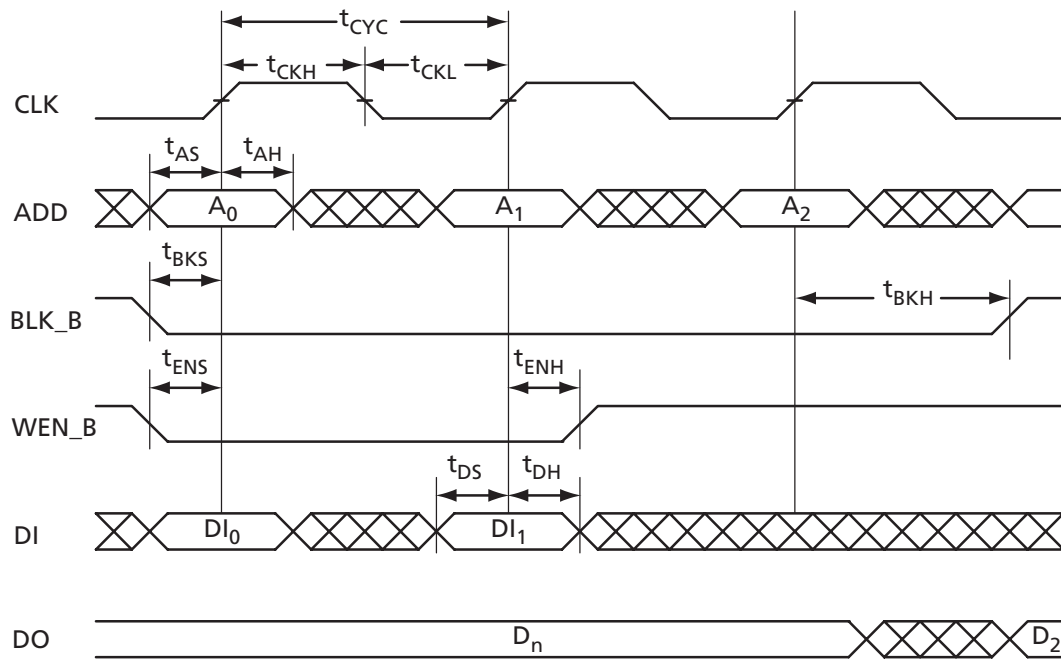

Figure 2-32 • RAM Write, Output Retained (WMODE = 0)

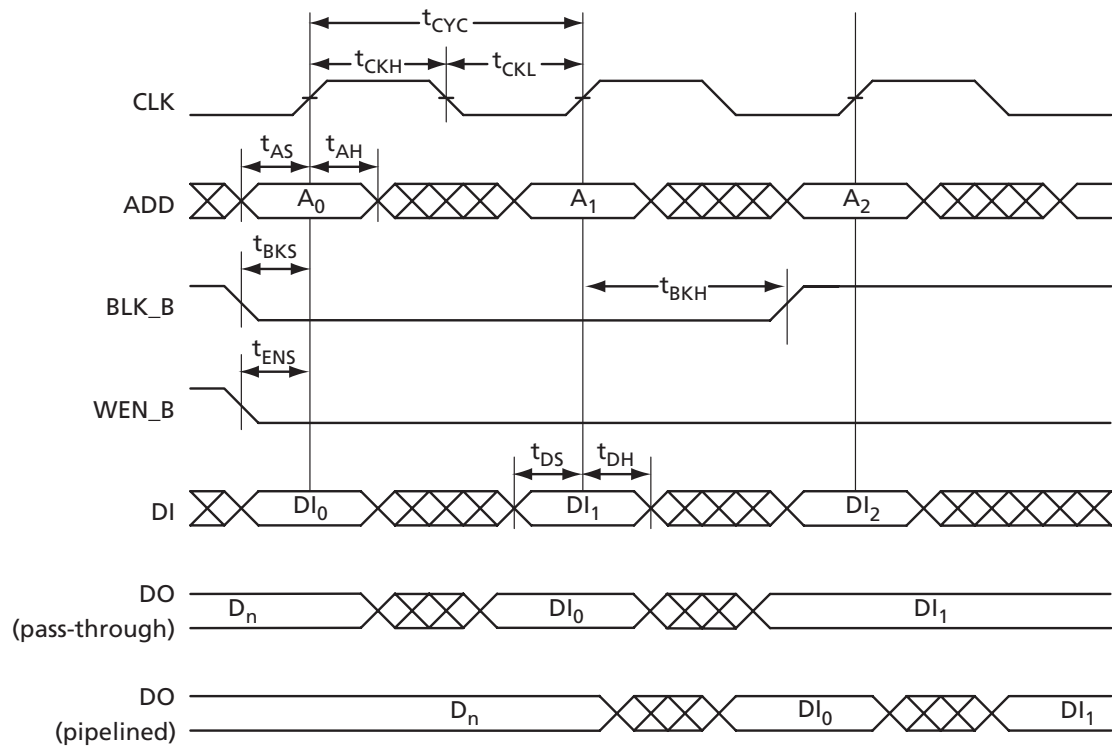

Figure 2-33 • RAM Write, Output as Write Data (WMODE = 1)

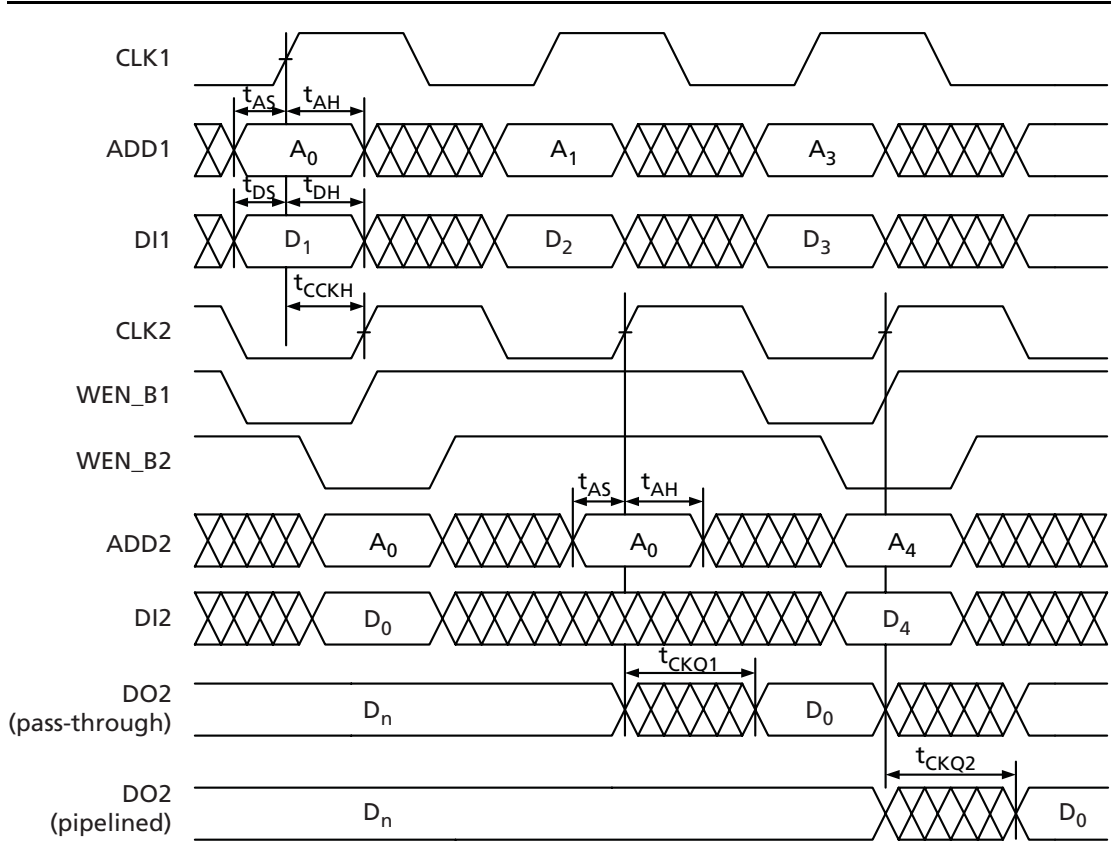

Figure 2-34 • Write Access after Write onto Same Address

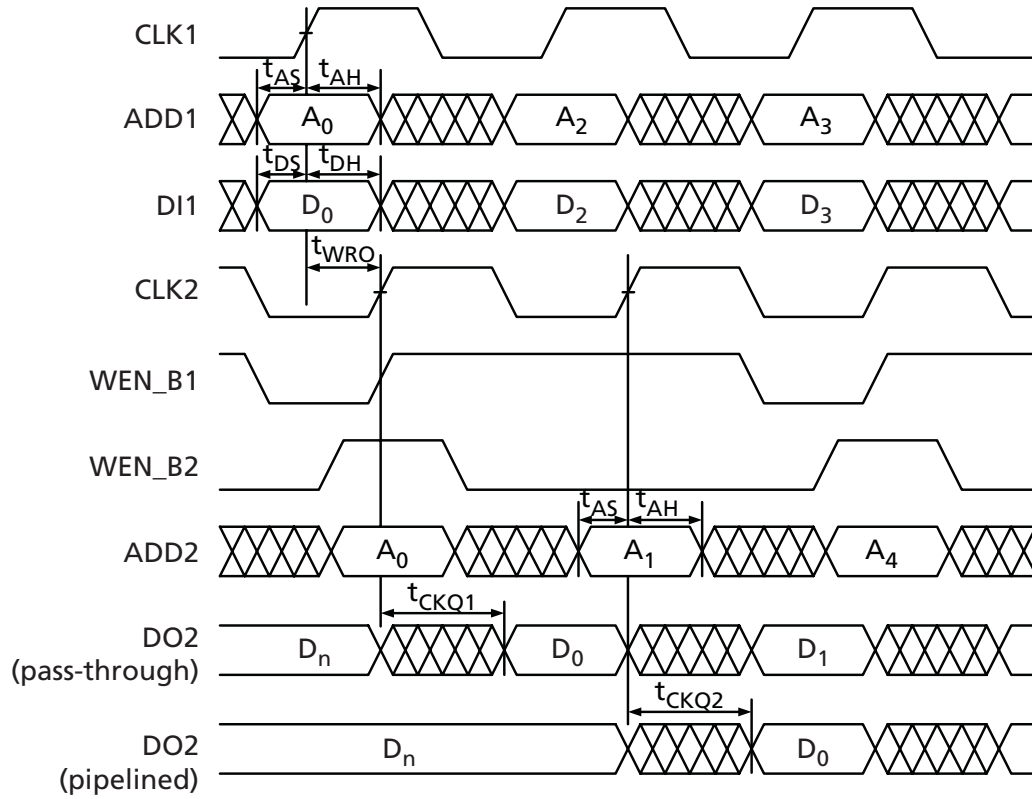

Figure 2-35 • Read Access after Write onto Same Address

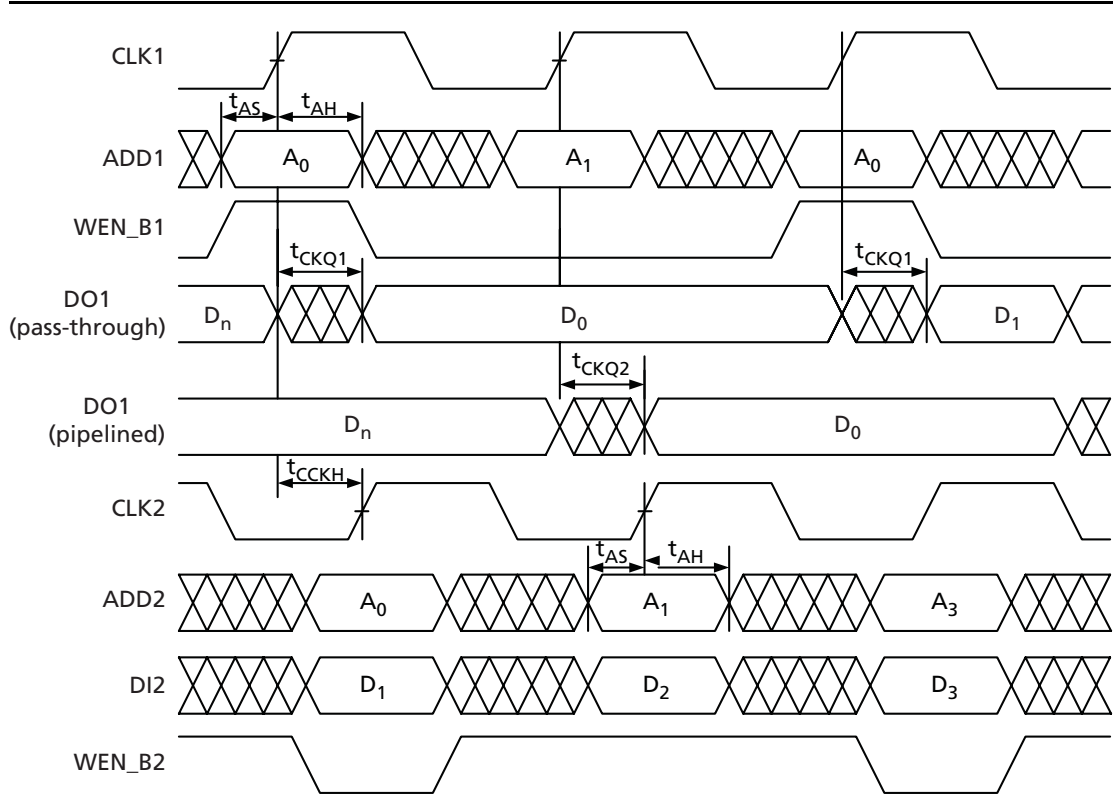

Figure 2-36 • Write Access after Read onto Same Address

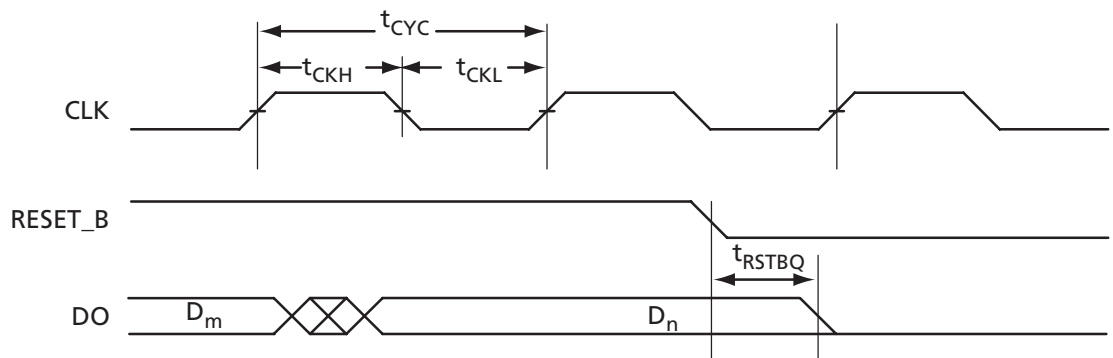

Figure 2-37 • RAM Reset

Timing Characteristics

Table 2-107 • RAM4K9

Commercial-Case Conditions: $T_J = 70^\circ\text{C}$, Worst-Case $V_{CC} = 1.425\text{ V}$

Parameter	Description	-2	-1	Std.	-F	Units
t_{AS}	Address setup time	0.25	0.28	0.33	0.40	ns
t_{AH}	Address hold time	0.00	0.00	0.00	0.00	ns
t_{ENS}	REN_B, WEN_B setup time	0.14	0.16	0.19	0.23	ns
t_{ENH}	REN_B, WEN_B hold time	0.10	0.11	0.13	0.16	ns
t_{BKS}	BLK_B setup time	0.23	0.27	0.31	0.37	ns
t_{BKH}	BLK_B hold time	0.02	0.02	0.02	0.03	ns
t_{DS}	Input data (DI) setup time	0.18	0.21	0.25	0.29	ns
t_{DH}	Input data (DI) hold time	0.00	0.00	0.00	0.00	ns
t_{CKQ1}	Clock HIGH to new data valid on DO (output retained, WMODE = 0)	2.36	2.68	3.15	3.79	ns
	Clock HIGH to new data valid on DO (flow-through, WMODE = 1)	1.79	2.03	2.39	2.87	ns
t_{CKQ2}	Clock HIGH to new data valid on DO (pipelined)	0.89	1.02	1.20	1.44	ns
t_{WRO}	Address collision clk-to-clk delay for reliable read access after write on same address	TBD	TBD	TBD	TBD	ns
t_{CCKH}	Address collision clk-to-clk delay for reliable write access after write/read on same address	TBD	TBD	TBD	TBD	ns
t_{RSTBQ}	RESET_B LOW to data out LOW on DO (flow-through)	0.92	1.05	1.23	1.48	ns
	RESET_B LOW to Data Out LOW on DO (pipelined)	0.92	1.05	1.23	1.48	ns
$t_{REMRSTB}$	RESET_B removal	0.29	0.33	0.38	0.46	ns
$t_{RECRSTB}$	RESET_B recovery	1.50	1.71	2.01	2.41	ns
$t_{MPWRSTB}$	RESET_B minimum pulse width	0.21	0.24	0.29	0.34	ns
t_{CYC}	Clock cycle time	3.23	3.68	4.32	5.19	ns
F_{MAX}	Maximum frequency	310	272	231	193	MHz

Note: For specific junction temperature and voltage supply levels, refer to [Table 2-6 on page 2-6](#) for derating values.

Table 2-108 • RAM512X18
Commercial-Case Conditions: $T_J = 70^\circ\text{C}$, Worst-Case $V_{CC} = 1.425\text{ V}$

Parameter	Description	-2	-1	Std.	-F	Units
t_{AS}	Address setup time	0.25	0.28	0.33	0.40	ns
t_{AH}	Address hold time	0.00	0.00	0.00	0.00	ns
t_{ENS}	REN_B, WEN_B setup time	0.13	0.15	0.17	0.21	ns
t_{ENH}	REN_B, WEN_B hold time	0.10	0.11	0.13	0.16	ns
t_{DS}	Input data (DI) setup time	0.18	0.21	0.25	0.29	ns
t_{DH}	Input data (DI) hold time	0.00	0.00	0.00	0.00	ns
t_{CKQ1}	Clock HIGH to new data valid on DO (output retained, WMODE = 0)	2.16	2.46	2.89	3.47	ns
t_{CKQ2}	Clock HIGH to new data valid on DO (pipelined)	0.90	1.02	1.20	1.44	ns
t_{WRO}	Address collision clk-to-clk delay for reliable read access after write on same address	TBD	TBD	TBD	TBD	ns
t_{CCKH}	Address collision clk-to-clk delay for reliable write access after write/read on same address	TBD	TBD	TBD	TBD	ns
t_{RSTBQ}	RESET_B LOW to data out LOW on DO (flow-through)	0.92	1.05	1.23	1.48	ns
	RESET_B LOW to data out LOW on DO (pipelined)	0.92	1.05	1.23	1.48	ns
$t_{REMRSTB}$	RESET_B removal	0.29	0.33	0.38	0.46	ns
$t_{RECRSTB}$	RESET_B recovery	1.50	1.71	2.01	2.41	ns
$t_{MPWRSTB}$	RESET_B minimum pulse width	0.21	0.24	0.29	0.34	ns
t_{CYC}	Clock cycle time	3.23	3.68	4.32	5.19	ns
F_{MAX}	Maximum frequency	310	272	231	193	MHz

Note: For specific junction temperature and voltage supply levels, refer to [Table 2-6 on page 2-6](#) for derating values.

FIFO

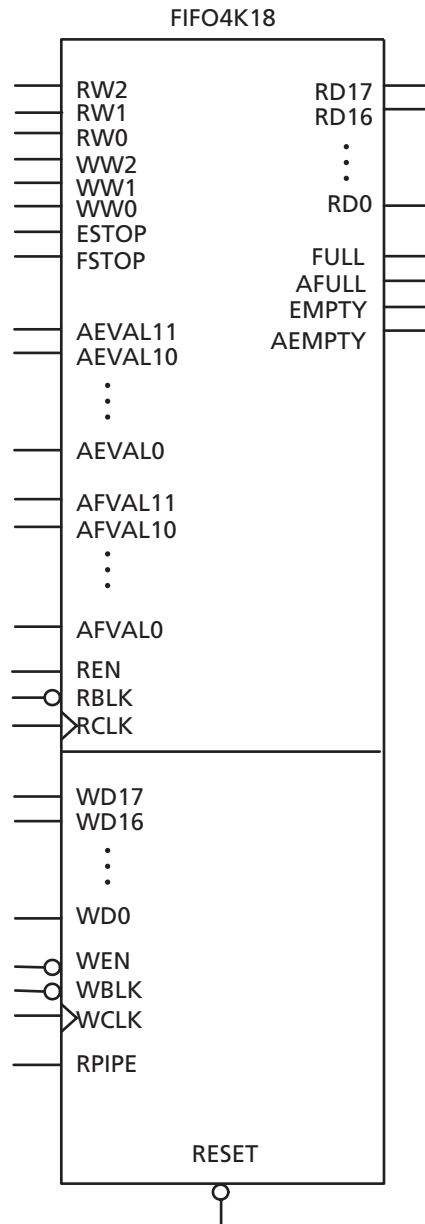

Figure 2-38 • FIFO Model

Timing Waveforms

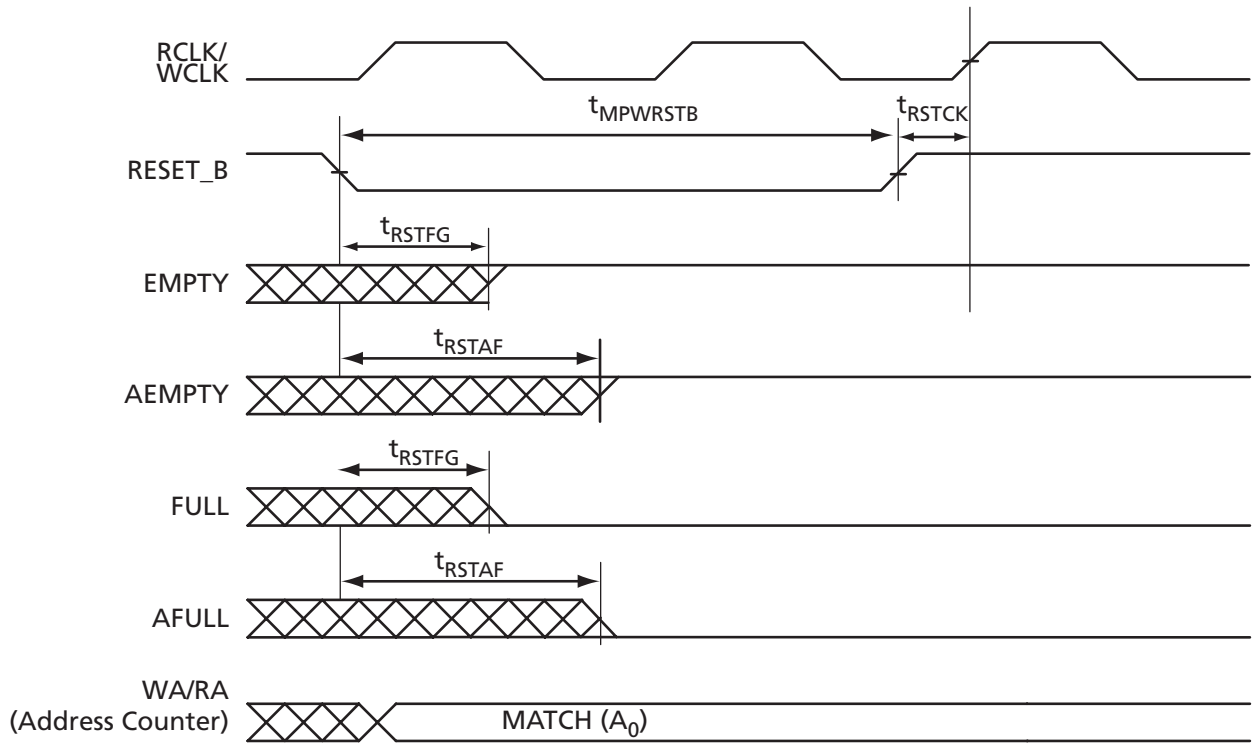

Figure 2-39 • FIFO Reset

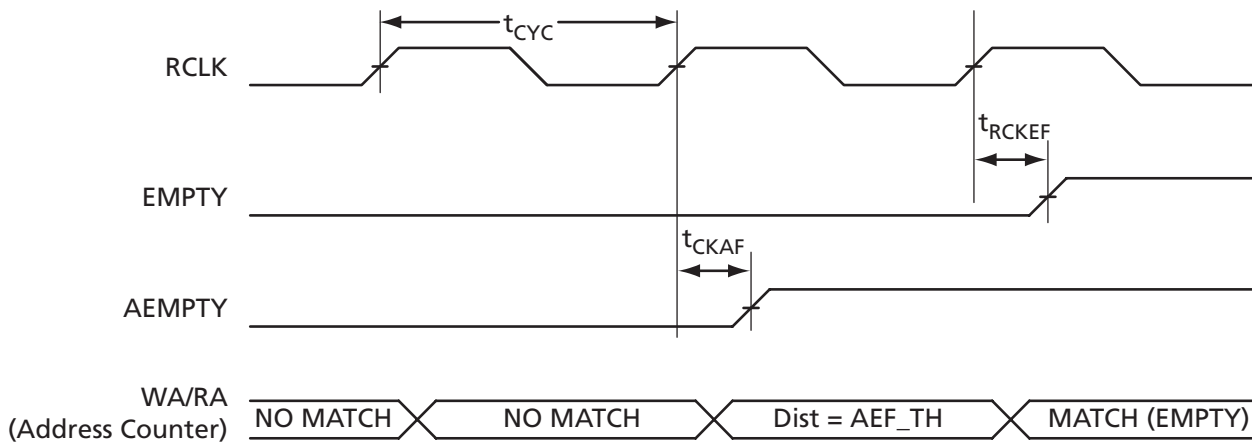
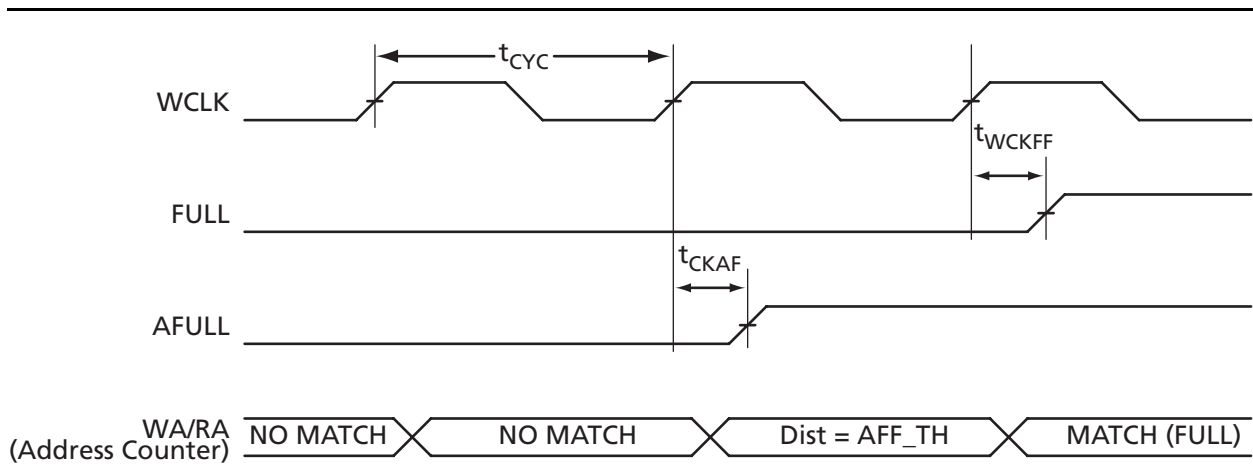
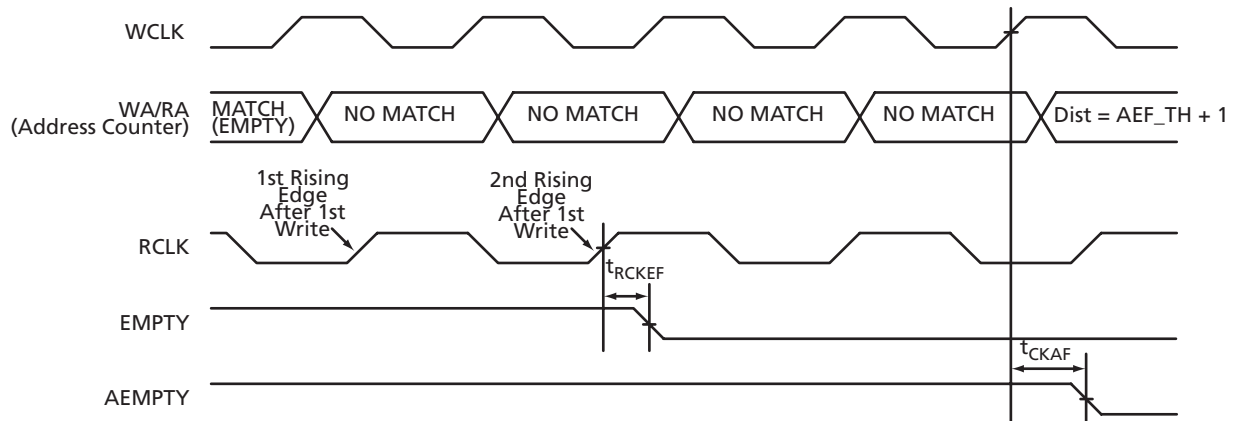
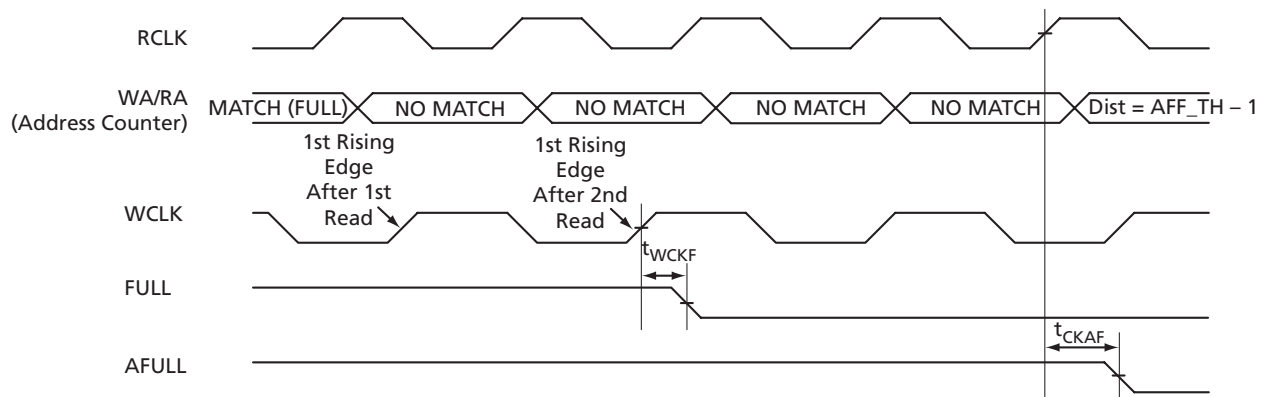

Figure 2-40 • FIFO EMPTY Flag and AEMPTY Flag Assertion

Figure 2-41 • FIFO FULL Flag and AFULL Flag Assertion

Figure 2-42 • FIFO EMPTY Flag and AEMPTY Flag Deassertion

Figure 2-43 • FIFO FULL Flag and AFULL Flag Deassertion

Timing Characteristics

Table 2-109 • FIFO (for all dies except A3P250)
Worst Commercial-Case Conditions: $T_j = 70^\circ\text{C}$, $V_{CC} = 1.425\text{ V}$

Parameter	Description	-2	-1	Std.	-F	Units
t_{ENS}	REN_B, WEN_B Setup Time	1.34	1.52	1.79	2.15	ns
t_{ENH}	REN_B, WEN_B Hold Time	0.00	0.00	0.00	0.00	ns
t_{BKS}	BLK_B Setup Time	0.19	0.22	0.26	0.31	ns
t_{BKH}	BLK_B Hold Time	0.00	0.00	0.00	0.00	ns
t_{DS}	Input Data (DI) Setup Time	0.18	0.21	0.25	0.29	ns
t_{DH}	Input Data (DI) Hold Time	0.00	0.00	0.00	0.00	ns
t_{CKQ1}	Clock HIGH to New Data Valid on DO (flow-through)	2.17	2.47	2.90	3.48	ns
t_{CKQ2}	Clock HIGH to New Data Valid on DO (pipelined)	0.94	1.07	1.26	1.52	ns
t_{RCKEF}	RCLK HIGH to Empty Flag Valid	1.72	1.96	2.30	2.76	ns
t_{WCKFF}	WCLK HIGH to Full Flag Valid	1.63	1.86	2.18	2.62	ns
t_{CKAF}	Clock HIGH to Almost Empty/Full Flag Valid	6.19	7.05	8.29	9.96	ns
t_{RSTFG}	RESET_B LOW to Empty/Full Flag Valid	1.69	1.93	2.27	2.72	ns
t_{RSTAF}	RESET_B LOW to Almost Empty/Full Flag Valid	6.13	6.98	8.20	9.85	ns
t_{RSTBQ}	RESET_B LOW to Data Out LOW on DO (flow-through)	0.92	1.05	1.23	1.48	ns
	RESET_B LOW to Data Out LOW on DO (pipelined)	0.92	1.05	1.23	1.48	ns
$t_{REMRSTB}$	RESET_B Removal	0.29	0.33	0.38	0.46	ns
$t_{RECRSTB}$	RESET_B Recovery	1.50	1.71	2.01	2.41	ns
$t_{MPWRSTB}$	RESET_B Minimum Pulse Width	0.21	0.24	0.29	0.34	ns
t_{CYC}	Clock Cycle Time	3.23	3.68	4.32	5.19	ns
F_{MAX}	Maximum Frequency for FIFO	310	272	231	193	MHz

Note: For specific junction temperature and voltage supply levels, refer to [Table 2-6 on page 2-6](#) for derating values.

Table 2-110 • FIFO (for A3P250 only, aspect-ratio-dependent)
Worst Commercial-Case Conditions: $T_J = 70^\circ\text{C}$, $V_{CC} = 1.425\text{ V}$

Parameter	Description	-2	-1	Std.	-F	Units
t_{ENS}	REN_B, WEN_B Setup Time	3.26	3.71	4.36	5.24	ns
t_{ENH}	REN_B, WEN_B Hold Time	0.00	0.00	0.00	0.00	ns
t_{BKS}	BLK_B Setup Time	0.19	0.22	0.26	0.31	ns
t_{BKH}	BLK_B Hold Time	0.00	0.00	0.00	0.00	ns
t_{DS}	Input Data (DI) Setup Time	0.18	0.21	0.25	0.29	ns
t_{DH}	Input Data (DI) Hold Time	0.00	0.00	0.00	0.00	ns
t_{CKQ1}	Clock HIGH to New Data Valid on DO (flow-through)	2.17	2.47	2.90	3.48	ns
t_{CKQ2}	Clock HIGH to New Data Valid on DO (pipelined)	0.94	1.07	1.26	1.52	ns
t_{RCKEF}	RCLK HIGH to Empty Flag Valid	1.72	1.96	2.30	2.76	ns
t_{WCKFF}	WCLK HIGH to Full Flag Valid	1.63	1.86	2.18	2.62	ns
t_{CKAF}	Clock HIGH to Almost Empty/Full Flag Valid	6.19	7.05	8.29	9.96	ns
t_{RSTFG}	RESET_B LOW to Empty/Full Flag Valid	1.69	1.93	2.27	2.72	ns
t_{RSTAF}	RESET_B LOW to Almost Empty/Full Flag Valid	6.13	6.98	8.20	9.85	ns
t_{RSTBQ}	RESET_B LOW to Data Out LOW on DO (flow-through)	0.92	1.05	1.23	1.48	ns
	RESET_B LOW to Data Out LOW on DO (pipelined)	0.92	1.05	1.23	1.48	ns
$t_{REMRSTB}$	RESET_B Removal	0.29	0.33	0.38	0.46	ns
$t_{RECRSTB}$	RESET_B Recovery	1.50	1.71	2.01	2.41	ns
$t_{MPWRSTB}$	RESET_B Minimum Pulse Width	0.21	0.24	0.29	0.34	ns
t_{CYC}	Clock Cycle Time	3.23	3.68	4.32	5.19	ns
F_{MAX}	Maximum Frequency for FIFO	310	272	231	193	MHz

Table 2-111 • A3P250 FIFO 512x8
Worst Commercial-Case Conditions: $T_J = 70^\circ\text{C}$, $V_{CC} = 1.425\text{ V}$

Parameter	Description	-2	-1	Std.	-F	Units
t_{ENS}	REN_B, WEN_B Setup Time	3.75	4.27	5.02	6.04	ns
t_{ENH}	REN_B, WEN_B Hold Time	0.00	0.00	0.00	0.00	ns
t_{BKS}	BLK_B Setup Time	0.19	0.22	0.26	0.31	ns
t_{BKH}	BLK_B Hold Time	0.00	0.00	0.00	0.00	ns
t_{DS}	Input Data (DI) Setup Time	0.18	0.21	0.25	0.29	ns
t_{DH}	Input Data (DI) Hold Time	0.00	0.00	0.00	0.00	ns
t_{CKQ1}	Clock HIGH to New Data Valid on DO (flow-through)	2.17	2.47	2.90	3.48	ns
t_{CKQ2}	Clock HIGH to New Data Valid on DO (pipelined)	0.94	1.07	1.26	1.52	ns
t_{RCKEF}	RCLK HIGH to Empty Flag Valid	1.72	1.96	2.30	2.76	ns
t_{WCKFF}	WCLK HIGH to Full Flag Valid	1.63	1.86	2.18	2.62	ns
t_{CKAF}	Clock HIGH to Almost Empty/Full Flag Valid	6.19	7.05	8.29	9.96	ns
t_{RSTFG}	RESET_B LOW to Empty/Full Flag Valid	1.69	1.93	2.27	2.72	ns
t_{RSTAF}	RESET_B LOW to Almost Empty/Full Flag Valid	6.13	6.98	8.20	9.85	ns
t_{RSTBQ}	RESET_B LOW to Data Out LOW on DO (flow-through)	0.92	1.05	1.23	1.48	ns
	RESET_B LOW to Data Out LOW on DO (pipelined)	0.92	1.05	1.23	1.48	ns
$t_{REMRSTB}$	RESET_B Removal	0.29	0.33	0.38	0.46	ns
$t_{RECRSTB}$	RESET_B Recovery	1.50	1.71	2.01	2.41	ns
$t_{MPWRSTB}$	RESET_B Minimum Pulse Width	0.21	0.24	0.29	0.34	ns
t_{CYC}	Clock Cycle Time	3.23	3.68	4.32	5.19	ns
F_{MAX}	Maximum Frequency for FIFO	310	272	231	193	MHz

Table 2-112 • A3P250 FIFO 1kx4
Worst Commercial-Case Conditions: $T_J = 70^\circ\text{C}$, $V_{CC} = 1.425\text{ V}$

Parameter	Description	-2	-1	Std.	-F	Units
t_{ENS}	REN_B, WEN_B Setup Time	4.05	4.61	5.42	6.52	ns
t_{ENH}	REN_B, WEN_B Hold Time	0.00	0.00	0.00	0.00	ns
t_{BKS}	BLK_B Setup Time	0.19	0.22	0.26	0.31	ns
t_{BKH}	BLK_B Hold Time	0.00	0.00	0.00	0.00	ns
t_{DS}	Input Data (DI) Setup Time	0.18	0.21	0.25	0.29	ns
t_{DH}	Input Data (DI) Hold Time	0.00	0.00	0.00	0.00	ns
t_{CKQ1}	Clock HIGH to New Data Valid on DO (flow-through)	2.36	2.68	3.15	3.79	ns
t_{CKQ2}	Clock HIGH to New Data Valid on DO (pipelined)	0.89	1.02	1.20	1.44	ns
t_{RCKEF}	RCLK HIGH to Empty Flag Valid	1.72	1.96	2.30	2.76	ns
t_{WCKFF}	WCLK HIGH to Full Flag Valid	1.63	1.86	2.18	2.62	ns
t_{CKAF}	Clock HIGH to Almost Empty/Full Flag Valid	6.19	7.05	8.29	9.96	ns
t_{RSTFG}	RESET_B LOW to Empty/Full Flag Valid	1.69	1.93	2.27	2.72	ns
t_{RSTAF}	RESET_B LOW to Almost Empty/Full Flag Valid	6.13	6.98	8.20	9.85	ns
t_{RSTBQ}	RESET_B LOW to Data Out LOW on DO (flow-through)	0.92	1.05	1.23	1.48	ns
	RESET_B LOW to Data Out LOW on DO (pipelined)	0.92	1.05	1.23	1.48	ns
$t_{REMRSTB}$	RESET_B Removal	0.29	0.33	0.38	0.46	ns
$t_{RECRSTB}$	RESET_B Recovery	1.50	1.71	2.01	2.41	ns
$t_{MPWRSTB}$	RESET_B Minimum Pulse Width	0.21	0.24	0.29	0.34	ns
t_{CYC}	Clock Cycle Time	3.23	3.68	4.32	5.19	ns
F_{MAX}	Maximum Frequency for FIFO	310	272	231	193	MHz

Table 2-113 • A3P250 FIFO 2kx2
Worst Commercial-Case Conditions: $T_J = 70^\circ\text{C}$, $V_{CC} = 1.425\text{ V}$

Parameter	Description	-2	-1	Std.	-F	Units
t_{ENS}	REN_B, WEN_B Setup Time	4.39	5.00	5.88	7.06	ns
t_{ENH}	REN_B, WEN_B Hold Time	0.00	0.00	0.00	0.00	ns
t_{BKS}	BLK_B Setup Time	0.19	0.22	0.26	0.31	ns
t_{BKH}	BLK_B Hold Time	0.00	0.00	0.00	0.00	ns
t_{DS}	Input Data (DI) Setup Time	0.18	0.21	0.25	0.29	ns
t_{DH}	Input Data (DI) Hold Time	0.00	0.00	0.00	0.00	ns
t_{CKQ1}	Clock HIGH to New Data Valid on DO (flow-through)	2.36	2.68	3.15	3.79	ns
t_{CKQ2}	Clock HIGH to New Data Valid on DO (pipelined)	0.89	1.02	1.20	1.44	ns
t_{RCKEF}	RCLK HIGH to Empty Flag Valid	1.72	1.96	2.30	2.76	ns
t_{WCKFF}	WCLK HIGH to Full Flag Valid	1.63	1.86	2.18	2.62	ns
t_{CKAF}	Clock HIGH to Almost Empty/Full Flag Valid	6.19	7.05	8.29	9.96	ns
t_{RSTFG}	RESET_B LOW to Empty/Full Flag Valid	1.69	1.93	2.27	2.72	ns
t_{RSTAF}	RESET_B LOW to Almost Empty/Full Flag Valid	6.13	6.98	8.20	9.85	ns
t_{RSTBQ}	RESET_B LOW to Data Out LOW on DO (flow-through)	0.92	1.05	1.23	1.48	ns
	RESET_B LOW to Data Out LOW on DO (pipelined)	0.92	1.05	1.23	1.48	ns
$t_{REMRSTB}$	RESET_B Removal	0.29	0.33	0.38	0.46	ns
$t_{RECRSTB}$	RESET_B Recovery	1.50	1.71	2.01	2.41	ns
$t_{MPWRSTB}$	RESET_B Minimum Pulse Width	0.21	0.24	0.29	0.34	ns
t_{CYC}	Clock Cycle Time	3.23	3.68	4.32	5.19	ns
F_{MAX}	Maximum Frequency for FIFO	310	272	231	193	MHz

Table 2-114 • A3P250 FIFO 4kx1

Worst Commercial-Case Conditions: $T_J = 70^\circ\text{C}$, $V_{CC} = 1.425\text{ V}$

Parameter	Description	-2	-1	Std.	-F	Units
t_{ENS}	REN_B, WEN_B Setup Time	4.86	5.53	6.50	7.81	ns
t_{ENH}	REN_B, WEN_B Hold Time	0.00	0.00	0.00	0.00	ns
t_{BKS}	BLK_B Setup Time	0.19	0.22	0.26	0.31	ns
t_{BKH}	BLK_B Hold Time	0.00	0.00	0.00	0.00	ns
t_{DS}	Input Data (DI) Setup Time	0.18	0.21	0.25	0.29	ns
t_{DH}	Input Data (DI) Hold Time	0.00	0.00	0.00	0.00	ns
t_{CKQ1}	Clock HIGH to New Data Valid on DO (flow-through)	2.36	2.68	3.15	3.79	ns
t_{CKQ2}	Clock HIGH to New Data Valid on DO (pipelined)	0.89	1.02	1.20	1.44	ns
t_{RCKEF}	RCLK HIGH to Empty Flag Valid	1.72	1.96	2.30	2.76	ns
t_{WCKFF}	WCLK HIGH to Full Flag Valid	1.63	1.86	2.18	2.62	ns
t_{CKAF}	Clock HIGH to Almost Empty/Full Flag Valid	6.19	7.05	8.29	9.96	ns
t_{RSTFG}	RESET_B LOW to Empty/Full Flag Valid	1.69	1.93	2.27	2.72	ns
t_{RSTAF}	RESET_B LOW to Almost Empty/Full Flag Valid	6.13	6.98	8.20	9.85	ns
t_{RSTBQ}	RESET_B LOW to Data Out LOW on DO (pass-through)	0.92	1.05	1.23	1.48	ns
	RESET_B LOW to Data Out LOW on DO (pipelined)	0.92	1.05	1.23	1.48	ns
$t_{REMRSTB}$	RESET_B Removal	0.29	0.33	0.38	0.46	ns
$t_{RECRSTB}$	RESET_B Recovery	1.50	1.71	2.01	2.41	ns
$t_{MPWRSTB}$	RESET_B Minimum Pulse Width	0.21	0.24	0.29	0.34	ns
t_{CYC}	Clock Cycle Time	3.23	3.68	4.32	5.19	ns
F_{MAX}	Maximum Frequency	310	272	231	193	MHz

Embedded FlashROM Characteristics

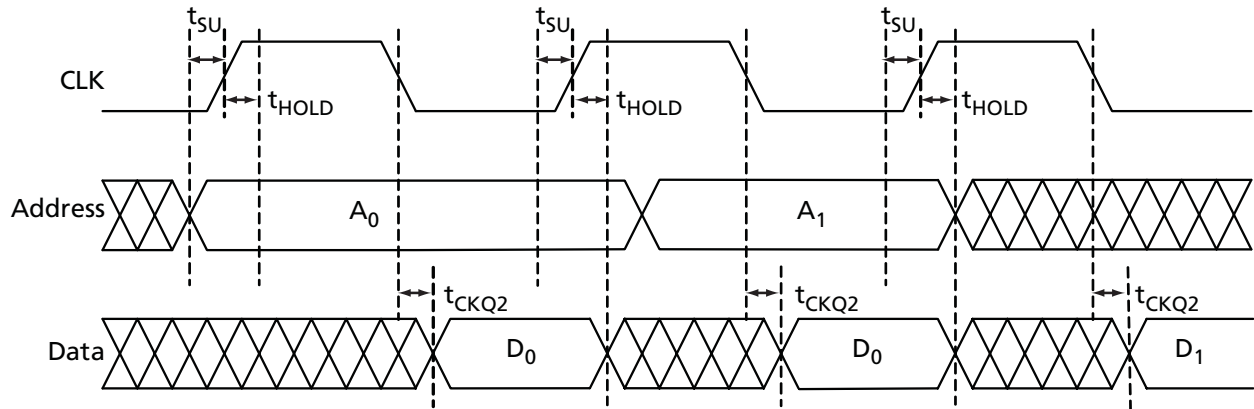

Figure 2-44 • Timing Diagram

Timing Characteristics

Table 2-115 • Embedded FlashROM Access Time

Parameter	Description	-2	-1	Std.	Units
t_{SU}	Address Setup Time	0.53	0.61	0.71	ns
t_{HOLD}	Address Hold Time	0.00	0.00	0.00	ns
t_{CKQ2}	Clock to Out	21.42	24.40	28.68	ns
F_{MAX}	Maximum Clock Frequency	15	15	15	MHz

JTAG 1532 Characteristics

JTAG timing delays do not include JTAG I/Os. To obtain complete JTAG timing, add I/O buffer delays to the corresponding standard selected; refer to the I/O timing characteristics in the "User I/O Characteristics" section on page 2-15 for more details.

Timing Characteristics

Table 2-116 • JTAG 1532

Commercial-Case Conditions: $T_J = 70^\circ\text{C}$, Worst-Case $V_{CC} = 1.425\text{ V}$

Parameter	Description	-2	-1	Std.	Units
t_{DISU}	Test Data Input Setup Time	0.50	0.57	0.67	ns
t_{DIHD}	Test Data Input Hold Time	1.00	1.13	1.33	ns
t_{TMSSU}	Test Mode Select Setup Time	0.50	0.57	0.67	ns
t_{TMDHD}	Test Mode Select Hold Time	1.00	1.13	1.33	ns
t_{TCK2Q}	Clock to Q (data out)	6.00	6.80	8.00	ns
t_{RSTB2Q}	Reset to Q (data out)	20.00	22.67	26.67	ns
F_{TCKMAX}	TCK Maximum Frequency	25.00	22.00	19.00	MHz
$t_{TRSTREM}$	ResetB Removal Time	0.00	0.00	0.00	ns
$t_{TRSTREC}$	ResetB Recovery Time	0.20	0.23	0.27	ns
$t_{TRSTMPW}$	ResetB Minimum Pulse	TBD	TBD	TBD	ns

Note: For specific junction temperature and voltage supply levels, refer to Table 2-6 on page 2-6 for derating values.

Part Number and Revision Date

Part Number 51700097-002-3
Revised August 2008

List of Changes

The following table lists critical changes that were made in the current version of the chapter.

Previous Version	Changes in Current Version (v1.3)	Page
v1.2 (June 2008)	T _J , Maximum Junction Temperature, was changed to 100° from 110° in the "Thermal Characteristics" section and EQ 2-2. The calculated result of Maximum Power Allowed has thus changed to 1.463 W from 1.951 W.	2-5
	Values for the A3P015 device were added to Table 2-7 · Quiescent Supply Current Characteristics.	2-6
	Values for the A3P015 device were added to Table 2-14 · Different Components Contributing to Dynamic Power Consumption in ProASIC3 Devices. P _{AC14} was removed. Table 2-15 · Different Components Contributing to the Static Power Consumption in ProASIC3 Devices is new.	2-10, 2-11
	The "PLL Contribution—PPLL" section was updated to change the P _{PLL} formula from P _{AC13} + P _{AC14} * F _{CLKOUT} to P _{DC4} + P _{AC13} * F _{CLKOUT} .	2-13
	Both fall and rise values were included for t _{DDRISUD} and t _{DDRIHD} in Table 2-93 · Input DDR Propagation Delays.	2-71
	Table 2-98 · A3P015 Global Resource is new.	2-79
	The typical value for Delay Increments in Programmable Delay Blocks was changed from 160 to 200 in Table 2-106 · ProASIC3 CCC/PLL Specification.	2-83
v1.1 (January 2008)	Table note references were added to Table 2-2 · Recommended Operating Conditions ¹ , and the order of the table notes was changed.	2-2
	The title for Table 2-4 · Overshoot and Undershoot Limits 1 was modified to remove "as measured on quiet I/Os." Table note 1 was revised to remove "estimated SSO density over cycles." Table note 2 was revised to remove "refers only to overshoot/undershoot limits for simultaneous switching I/Os."	2-3
	The "Power per I/O Pin" section was updated to include 3 additional tables pertaining to input buffer power and output buffer power.	2-6
	Table 2-29 · I/O Output Buffer Maximum Resistances ¹ was revised to include values for 3.3 V PCI/PCI-X.	2-24
	Table 2-81 · LVDS Minimum and Maximum DC Input and Output Levels was updated.	2-59
v1.0 (January 2008)	In Table 2-2 · Recommended Operating Conditions ¹ , T _J was listed in the symbol column and was incorrect. It was corrected and changed to T _A .	2-2
	In Table 2-3 · Flash Programming Limits – Retention, Storage and Operating Temperature ¹ , Maximum Operating Junction Temperature was changed from 110°C to 100°C for both commercial and industrial grades.	2-2
	The "PLL Behavior at Brownout Condition" section is new.	2-3
	In the "PLL Contribution—PPLL" section, the following was deleted: FCLKIN is the input clock frequency.	2-13
	In Table 2-21 · Summary of Maximum and Minimum DC Input Levels, the note was incorrect. It previously said T _J and it was corrected and changed to T _A .	2-20

Previous Version	Changes in Current Version (v1.3)	Page
v1.0 (continued)	In Table 2-106 · ProASIC3 CCC/PLL Specification , the SCLK parameter and note 1 are new.	2-83
	Table 2-116 · JTAG 1532 was populated with the parameter data, which was not in the previous version of the document.	2-103
v2.2 (July 2007)	This document was previously in datasheet v2.2. As a result of moving to the handbook format, Actel restarted the version numbers so the new version number is v1.0.	N/A
v2.1 (May 2007)	The T_J parameter in Table 3-2 · Recommended Operating Conditions was changed to T_A , ambient temperature, and table notes 4–6 were added.	3-2
v2.0 (April 2007)	Table 3-5 · Package Thermal Resistivities was updated with A3P1000 information. The note below the table is also new.	3-5
Advance v0.7 (January 2007)	The timing characteristics tables were updated.	N/A
	The "PLL Macro" section was updated to add information on the VCO and PLL outputs during power-up.	2-15
	The "PLL Macro" section was updated to include power-up information.	2-15
	Table 2-11 · ProASIC3 CCC/PLL Specification was updated.	2-29
	Figure 2-19 · Peak-to-Peak Jitter Definition is new.	2-18
	The "SRAM and FIFO" section was updated with operation and timing requirement information.	2-21
	The "RESET" section was updated with read and write information.	2-25
	The "RESET" section was updated with read and write information.	2-25
	The "Introduction" in the "Advanced I/Os" section was updated to include information on input and output buffers being disabled.	2-28
	PCI-X 3.3 V was added to Table 2-11 · VCCI Voltages and Compatible Standards .	2-29
	In the Table 2-15 · Levels of Hot-Swap Support , the ProASIC3 compliance descriptions were updated for levels 3 and 4.	2-34
	Table 2-43 · I/O Hot-Swap and 5 V Input Tolerance Capabilities in ProASIC3 Devices was updated.	2-64
	Notes 3, 4, and 5 were added to Table 2-17 · Comparison Table for 5 V–Compliant Receiver Scheme . 5 x 52.72 was changed to 52.7 and the Maximum current was updated from 4 x 52.7 to 5 x 52.7.	2-40
	The "VCCPLF PLL Supply Voltage" section was updated.	2-50
	The "VPUMP Programming Supply Voltage" section was updated.	2-50
	The "GL Globals" section was updated to include information about direct input into quadrant clocks.	2-51
	V_{JTAG} was deleted from the "TCK Test Clock" section.	2-51
In Table 2-22 · Recommended Tie-Off Values for the TCK and TRST Pins , TSK was changed to TCK in note 2. Note 3 was also updated.	2-51	
Ambient was deleted from Table 3-2 · Recommended Operating Conditions . VPUMP programming mode was changed from "3.0 to 3.6" to "3.15 to 3.45".	3-2	
Note 3 is new in Table 3-4 · Overshoot and Undershoot Limits (as measured on quiet I/Os) ¹ .	3-2	

Previous Version	Changes in Current Version (v1.3)	Page
Advance v0.7 (continued)	In EQ 3-2, 150 was changed to 110 and the result changed from 3.9 to 1.951.	3-5
	Table 3-6 • Temperature and Voltage Derating Factors for Timing Delays was updated.	3-6
	Table 3-5 • Package Thermal Resistivities was updated.	3-5
	Table 3-14 • Summary of Maximum and Minimum DC Input and Output Levels Applicable to Commercial and Industrial Conditions—Software Default Settings (Advanced) and Table 3-17 • Summary of Maximum and Minimum DC Input Levels Applicable to Commercial and Industrial Conditions (Standard Plus) were updated.	3-17 to 3-17
	Table 3-20 • Summary of I/O Timing Characteristics—Software Default Settings (Advanced) and Table 3-21 • Summary of I/O Timing Characteristics—Software Default Settings (Standard Plus) were updated.	3-20 to 3-20
	Table 3-11 • Different Components Contributing to Dynamic Power Consumption in ProASIC3 Devices was updated.	3-9
	Table 3-24 • I/O Output Buffer Maximum Resistances1 (Advanced) and Table 3-25 • I/O Output Buffer Maximum Resistances1 (Standard Plus) were updated.	3-22 to 3-22
	Table 3-17 • Summary of Maximum and Minimum DC Input Levels Applicable to Commercial and Industrial Conditions was updated.	3-18
	Table 3-28 • I/O Short Currents IOSH/IOSL (Advanced) and Table 3-29 • I/O Short Currents IOSH/IOSL (Standard Plus) were updated.	3-24 to 3-26
	The note in Table 3-32 • I/O Input Rise Time, Fall Time, and Related I/O Reliability was updated.	3-27
	Figure 3-33 • Write Access After Write onto Same Address, Figure 3-34 • Read Access After Write onto Same Address, and Figure 3-35 • Write Access After Read onto Same Address are new.	3-82 to 3-84
	Figure 3-43 • Timing Diagram was updated.	3-96
Advance v0.5 (January 2006)	B-LVDS and M-LDVS are new I/O standards added to the datasheet.	N/A
	The term flow-through was changed to pass-through.	N/A
	Figure 2-7 • Efficient Long-Line Resources was updated.	2-7
	The footnotes in Figure 2-15 • Clock Input Sources Including CLKBUF, CLKBUF_LVDS/LVPECL, and CLKINT were updated.	2-16
	The Delay Increments in the Programmable Delay Blocks specification in Figure 2-24 • ProASIC3E CCC Options.	2-24
	The "SRAM and FIFO" section was updated.	2-21
	The "RESET" section was updated.	2-25
	The "WCLK and RCLK" section was updated.	2-25
	The "RESET" section was updated.	2-25
	The "RESET" section was updated.	2-27
The "Introduction" of the "Advanced I/Os" section was updated.	2-28	



Previous Version	Changes in Current Version (v1.3)	Page
Advance v0.5 (continued)	The "I/O Banks" section is new. This section explains the following types of I/Os: Advanced Standard+ Standard Table 2-12 • Automotive ProASIC3 Bank Types Definition and Differences is new. This table describes the standards listed above.	2-29
	PCI-X 3.3 V was added to the Compatible Standards for 3.3 V in Table 2-11 • VCCI Voltages and Compatible Standards	2-29
	Table 2-13 • ProASIC3 I/O Features was updated.	2-30
	The "Double Data Rate (DDR) Support" section was updated to include information concerning implementation of the feature.	2-32
	The "Electrostatic Discharge (ESD) Protection" section was updated to include testing information.	2-35
	Level 3 and 4 descriptions were updated in Table 2-43 • I/O Hot-Swap and 5 V Input Tolerance Capabilities in ProASIC3 Devices.	2-64
	The notes in Table 2-43 • I/O Hot-Swap and 5 V Input Tolerance Capabilities in ProASIC3 Devices were updated.	2-64
	The "Simultaneous Switching Outputs (SSOs) and Printed Circuit Board Layout" section is new.	2-41
	A footnote was added to Table 2-14 • Maximum I/O Frequency for Single-Ended and Differential I/Os in All Banks in Automotive ProASIC3 Devices (maximum drive strength and high slew selected).	2-30
	Table 2-18 • Automotive ProASIC3 I/O Attributes vs. I/O Standard Applications	2-45
	Table 2-50 • ProASIC3 Output Drive (OUT_DRIVE) for Standard I/O Bank Type (A3P030 device)	2-83
	Table 2-51 • ProASIC3 Output Drive for Standard+ I/O Bank Type was updated.	2-84
	Table 2-54 • ProASIC3 Output Drive for Advanced I/O Bank Type was updated.	2-84
	The "x" was updated in the "User I/O Naming Convention" section.	2-48
	The "V _{CC} Core Supply Voltage" pin description was updated.	2-50
	The "VMVx I/O Supply Voltage (quiet)" pin description was updated to include information concerning leaving the pin unconnected.	2-50
	The "V _{JTAG} JTAG Supply Voltage" pin description was updated.	2-50
	The "V _{PUMP} Programming Supply Voltage" pin description was updated to include information on what happens when the pin is tied to ground.	2-50
	The "I/O User Input/Output" pin description was updated to include information on what happens when the pin is unused.	2-50
	The "JTAG Pins" section was updated to include information on what happens when the pin is unused.	2-51
The "Programming" section was updated to include information concerning serialization.	2-53	
The "JTAG 1532" section was updated to include SAMPLE/PRELOAD information.	2-54	
"DC and Switching Characteristics" chapter was updated with new information.	3-1	

Previous Version	Changes in Current Version (v1.3)	Page
Advance v0.3	M7 device information is new.	N/A
	Table 2-4 • ProASIC3 Globals/Spines/Rows by Device was updated to include the number or rows in each top or bottom spine.	2-16
	EXTFB was removed from Figure 2-24 • ProASIC3E CCC Options.	2-24
	The "PLL Macro" section was updated. EXTFB information was removed from this section.	2-15
	The CCC Output Peak-to-Peak Period Jitter F_{CCC_OUT} was updated in Table 2-11 • ProASIC3 CCC/PLL Specification	2-29
	EXTFB was removed from Figure 2-27 • CCC/PLL Macro.	2-28
	Table 2-13 • ProASIC3 I/O Features was updated.	2-30
	The "Hot-Swap Support" section was updated.	2-33
	The "Cold-Sparing Support" section was updated.	2-34
	"Electrostatic Discharge (ESD) Protection" section was updated.	2-35
	The LVPECL specification in Table 2-43 • I/O Hot-Swap and 5 V Input Tolerance Capabilities in ProASIC3 Devices was updated.	2-64
	In the Bank 1 area of Figure 2-72, VMV2 was changed to VMV1 and V_{CC1B2} was changed to V_{CC1B1} .	2-97
	The VJTAG and I/O pin descriptions were updated in the "Pin Descriptions" section.	2-50
	The "JTAG Pins" section was updated.	2-51
	"128-Bit AES Decryption" section was updated to include M7 device information.	2-53
	Table 3-6 was updated.	3-6
	Table 3-7 was updated.	3-6
	In Table 3-11, PAC4 was updated.	3-93-8
	Table 3-20 was updated.	3-20
	The note in Table 3-32 was updated.	3-27
All Timing Characteristics tables were updated from LVTTTL to Register Delays	3-31 to 3-73	
The Timing Characteristics for RAM4K9, RAM512X18, and FIFO were updated.	3-85 to 3-90	
F_{TCKMAX} was updated in Table 3-110.	3-97	
Advance v0.2	Figure 2-11 was updated.	2-9
	The "Clock Resources (VersaNets)" section was updated.	2-9
	The "VersaNet Global Networks and Spine Access" section was updated.	2-9
	The "PLL Macro" section was updated.	2-15
	Figure 2-27 was updated.	2-28
	Figure 2-20 was updated.	2-19
	Table 2-5 was updated.	2-25
	Table 2-6 was updated.	2-25

Previous Version	Changes in Current Version (v1.3)	Page
Advance v0.2 (continued)	The "FIFO Flag Usage Considerations" section was updated.	2-27
	Table 2-13 was updated.	2-30
	Figure 2-24 was updated.	2-31
	The "Cold-Sparing Support" section is new.	2-34
	Table 2-43 was updated.	2-64
	Table 2-18 was updated.	2-45
	Pin descriptions in the "JTAG Pins" section were updated.	2-51
	The "User I/O Naming Convention" section was updated.	2-48
	Table 3-7 was updated.	3-6
	The "Methodology" section was updated.	3-10
	Table 3-40 and Table 3-39 were updated.	3-33, 3-32

Actel Safety Critical, Life Support, and High-Reliability Applications Policy

The Actel products described in this advance status datasheet may not have completed Actel's qualification process. Actel may amend or enhance products during the product introduction and qualification process, resulting in changes in device functionality or performance. It is the responsibility of each customer to ensure the fitness of any Actel product (but especially a new product) for a particular purpose, including appropriateness for safety-critical, life-support, and other high-reliability applications. Consult Actel's Terms and Conditions for specific liability exclusions relating to life-support applications. A reliability report covering all of Actel's products is available on the Actel website at http://www.actel.com/documents/ORT_Report.pdf. Actel also offers a variety of enhanced qualification and lot acceptance screening procedures. Contact your local Actel sales office for additional reliability information.





3 – Package Pin Assignments

68-Pin QFN

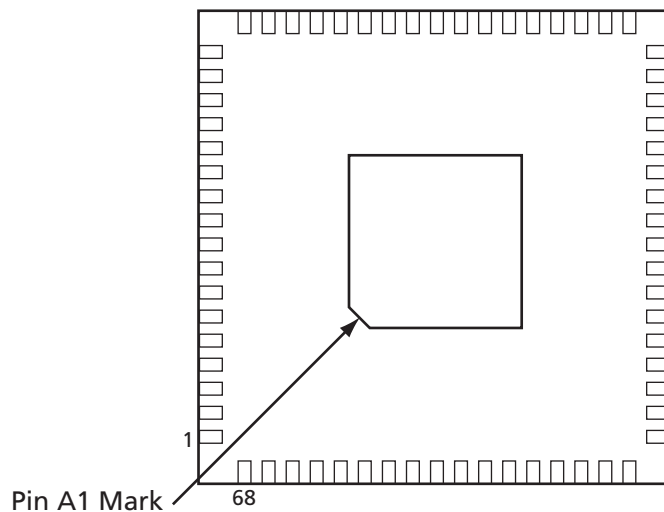

Notes:

1. This is the bottom view of the package.
2. The die attach paddle center of the package is tied to ground (GND).

Note

For Package Manufacturing and Environmental information, visit the Resource Center at <http://www.actel.com/products/solutions/package/docs.aspx>.

68-Pin QFN	
Pin Number	A3P015 Function
1	IO82RSB1
2	IO80RSB1
3	IO78RSB1
4	IO76RSB1
5	GEC0/IO73RSB1
6	GEA0/IO72RSB1
7	GEB0/IO71RSB1
8	V _{CC}
9	GND
10	V _{CC} B1
11	IO68RSB1
12	IO67RSB1
13	IO66RSB1
14	IO65RSB1
15	IO64RSB1
16	IO63RSB1
17	IO62RSB1
18	IO60RSB1
19	IO58RSB1
20	IO56RSB1
21	IO54RSB1
22	IO52RSB1
23	IO51RSB1
24	V _{CC}
25	GND
26	V _{CC} B1
27	IO50RSB1
28	IO48RSB1
29	IO46RSB1
30	IO44RSB1
31	IO42RSB1
32	TCK
33	TDI
34	TMS
35	V _{PUMP}
36	TDO

68-Pin QFN	
Pin Number	A3P015 Function
37	TRST
38	V _{JTAG}
39	IO40RSB0
40	IO37RSB0
41	GDB0/IO34RSB0
42	GDA0/IO33RSB0
43	GDC0/IO32RSB0
44	V _{CC} B0
45	GND
46	V _{CC}
47	IO31RSB0
48	IO29RSB0
49	IO28RSB0
50	IO27RSB0
51	IO25RSB0
52	IO24RSB0
53	IO22RSB0
54	IO21RSB0
55	IO19RSB0
56	IO17RSB0
57	IO15RSB0
58	IO14RSB0
59	V _{CC} B0
60	GND
61	V _{CC}
62	IO12RSB0
63	IO10RSB0
64	IO08RSB0
65	IO06RSB0
66	IO04RSB0
67	IO02RSB0
68	IO00RSB0

132-Pin QFN

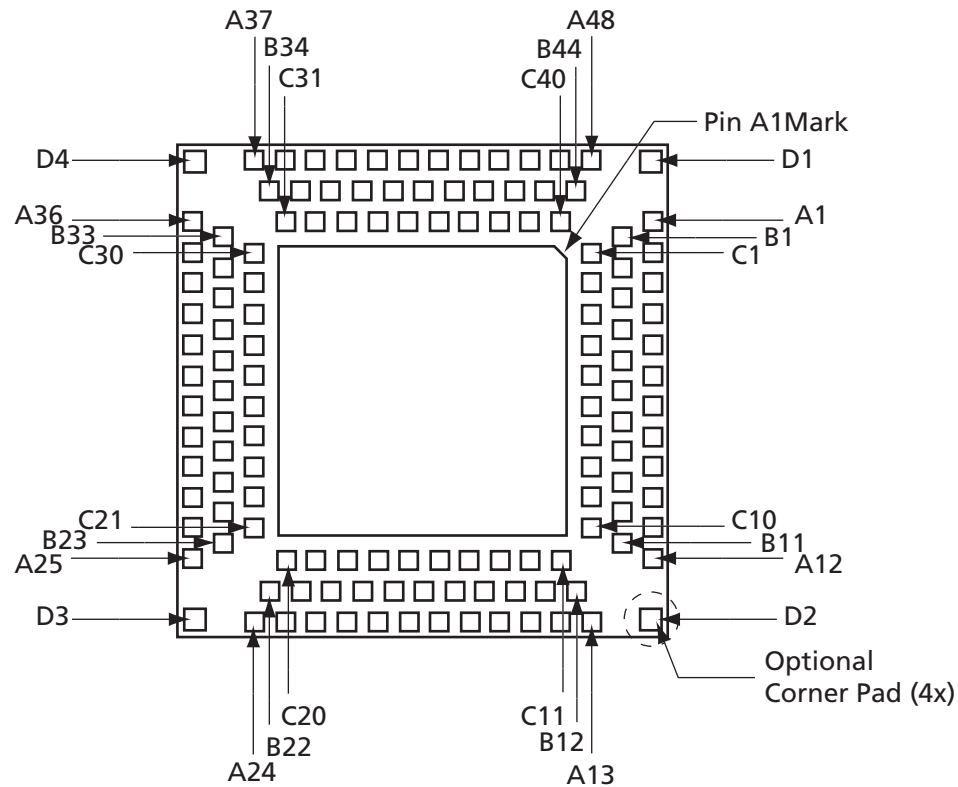

Notes:

1. This is the bottom view of the package.
2. The die attach paddle center of the package is tied to ground (GND).

Note

For Package Manufacturing and Environmental information, visit the Resource Center at <http://www.actel.com/products/solutions/package/docs.aspx>.

132-Pin QFN	
Pin Number	A3P030 Function
A1	IO1RSB1
A2	IO81RSB1
A3	NC
A4	IO80RSB1
A5	GEC0/IO77RSB1
A6	NC
A7	GEB0/IO75RSB1
A8	IO73RSB1
A9	NC
A10	V _{CC}
A11	IO71RSB1
A12	IO68RSB1
A13	IO63RSB1
A14	IO60RSB1
A15	NC
A16	IO59RSB1
A17	IO57RSB1
A18	V _{CC}
A19	IO54RSB1
A20	IO52RSB1
A21	IO49RSB1
A22	IO48RSB1
A23	IO47RSB1
A24	TDI
A25	TRST
A26	IO44RSB0
A27	NC
A28	IO43RSB0
A29	IO42RSB0
A30	IO40RSB0
A31	IO39RSB0
A32	GDC0/IO36RSB0
A33	NC
A34	V _{CC}
A35	IO34RSB0
A36	IO31RSB0

132-Pin QFN	
Pin Number	A3P030 Function
A37	IO26RSB0
A38	IO23RSB0
A39	NC
A40	IO22RSB0
A41	IO20RSB0
A42	IO18RSB0
A43	V _{CC}
A44	IO15RSB0
A45	IO12RSB0
A46	IO10RSB0
A47	IO09RSB0
A48	IO06RSB0
B1	IO02RSB1
B2	IO82RSB1
B3	GND
B4	IO79RSB1
B5	NC
B6	GND
B7	IO74RSB1
B8	NC
B9	GND
B10	IO70RSB1
B11	IO67RSB1
B12	IO64RSB1
B13	IO61RSB1
B14	GND
B15	IO58RSB1
B16	IO56RSB1
B17	GND
B18	IO53RSB1
B19	IO50RSB1
B20	GND
B21	IO46RSB1
B22	TMS
B23	TDO
B24	IO45RSB0

132-Pin QFN	
Pin Number	A3P030 Function
B25	GND
B26	NC
B27	IO41RSB0
B28	GND
B29	GDA0/IO37RSB0
B30	NC
B31	GND
B32	IO33RSB0
B33	IO30RSB0
B34	IO27RSB0
B35	IO24RSB0
B36	GND
B37	IO21RSB0
B38	IO19RSB0
B39	GND
B40	IO16RSB0
B41	IO13RSB0
B42	GND
B43	IO08RSB0
B44	IO05RSB0
C1	IO03RSB1
C2	IO00RSB1
C3	NC
C4	IO78RSB1
C5	GEA0/IO76RSB1
C6	NC
C7	NC
C8	V _{CC1} B1
C9	IO69RSB1
C10	IO66RSB1
C11	IO65RSB1
C12	IO62RSB1
C13	NC
C14	NC
C15	IO55RSB1
C16	V _{CC1} B1

132-Pin QFN	
Pin Number	A3P030 Function
C17	IO51RSB1
C18	NC
C19	TCK
C20	NC
C21	V _{PUMP}
C22	V _{JTAG}
C23	NC
C24	NC
C25	NC
C26	GDB0/IO38RSB0
C27	NC
C28	V _{CCIB0}
C29	IO32RSB0
C30	IO29RSB0
C31	IO28RSB0
C32	IO25RSB0
C33	NC
C34	NC
C35	V _{CCIB0}
C36	IO17RSB0
C37	IO14RSB0
C38	IO11RSB0
C39	IO07RSB0
C40	IO04RSB0
D1	GND
D2	GND
D3	GND
D4	GND

132-Pin QFN	
Pin Number	A3P060 Function
A1	GAB2/IO00RSB1
A2	IO93RSB1
A3	V _{CC} B1
A4	GFC1/IO89RSB1
A5	GFB0/IO86RSB1
A6	V _{CC} PLF
A7	GFA1/IO84RSB1
A8	GFC2/IO81RSB1
A9	IO78RSB1
A10	V _{CC}
A11	GEB1/IO75RSB1
A12	GEA0/IO72RSB1
A13	GEC2/IO69RSB1
A14	IO65RSB1
A15	V _{CC}
A16	IO64RSB1
A17	IO63RSB1
A18	IO62RSB1
A19	IO61RSB1
A20	IO58RSB1
A21	GDB2/IO55RSB1
A22	NC
A23	GDA2/IO54RSB1
A24	TDI
A25	TRST
A26	GDC1/IO48RSB0
A27	V _{CC}
A28	IO47RSB0
A29	GCC2/IO46RSB0
A30	GCA2/IO44RSB0
A31	GCA0/IO43RSB0
A32	GCB1/IO40RSB0
A33	IO36RSB0
A34	V _{CC}
A35	IO31RSB0
A36	GBA2/IO28RSB0

132-Pin QFN	
Pin Number	A3P060 Function
A37	GBB1/IO25RSB0
A38	GBC0/IO22RSB0
A39	V _{CC} B0
A40	IO21RSB0
A41	IO18RSB0
A42	IO15RSB0
A43	IO14RSB0
A44	IO11RSB0
A45	GAB1/IO08RSB0
A46	NC
A47	GAB0/IO07RSB0
A48	IO04RSB0
B1	IO01RSB1
B2	GAC2/IO94RSB1
B3	GND
B4	GFC0/IO88RSB1
B5	V _{COM} PLF
B6	GND
B7	GFB2/IO82RSB1
B8	IO79RSB1
B9	GND
B10	GEB0/IO74RSB1
B11	VMV1
B12	GEB2/IO70RSB1
B13	IO67RSB1
B14	GND
B15	NC
B16	NC
B17	GND
B18	IO59RSB1
B19	GDC2/IO56RSB1
B20	GND
B21	GNDQ
B22	TMS
B23	TDO
B24	GDC0/IO49RSB0

132-Pin QFN	
Pin Number	A3P060 Function
B25	GND
B26	NC
B27	GCB2/IO45RSB0
B28	GND
B29	GCB0/IO41RSB0
B30	GCC1/IO38RSB0
B31	GND
B32	GBB2/IO30RSB0
B33	VMV0
B34	GBA0/IO26RSB0
B35	GBC1/IO23RSB0
B36	GND
B37	IO20RSB0
B38	IO17RSB0
B39	GND
B40	IO12RSB0
B41	GAC0/IO09RSB0
B42	GND
B43	GAA1/IO06RSB0
B44	GNDQ
C1	GAA2/IO02RSB1
C2	IO95RSB1
C3	V _{CC}
C4	GFB1/IO87RSB1
C5	GFA0/IO85RSB1
C6	GFA2/IO83RSB1
C7	IO80RSB1
C8	V _{CC} B1
C9	GEA1/IO73RSB1
C10	GNDQ
C11	GEA2/IO71RSB1
C12	IO68RSB1
C13	V _{CC} B1
C14	NC
C15	NC
C16	IO60RSB1

132-Pin QFN	
Pin Number	A3P060 Function
C17	IO57RSB1
C18	NC
C19	TCK
C20	VMV1
C21	V _{PUMP}
C22	V _{JTAG}
C23	V _{CC} I _{B0}
C24	NC
C25	NC
C26	GCA1/IO42RSB0
C27	GCC0/IO39RSB0
C28	V _{CC} I _{B0}
C29	IO29RSB0
C30	GNDQ
C31	GBA1/IO27RSB0
C32	GBB0/IO24RSB0
C33	V _{CC}
C34	IO19RSB0
C35	IO16RSB0
C36	IO13RSB0
C37	GAC1/IO10RSB0
C38	NC
C39	GAA0/IO05RSB0
C40	VMV0
D1	GND
D2	GND
D3	GND
D4	GND

132-Pin QFN	
Pin Number	A3P125 Function
A1	GAB2/IO69RSB1
A2	IO130RSB1
A3	V _{CC} B1
A4	GFC1/IO126RSB1
A5	GFB0/IO123RSB1
A6	V _{CC} PLF
A7	GFA1/IO121RSB1
A8	GFC2/IO118RSB1
A9	IO115RSB1
A10	V _{CC}
A11	GEB1/IO110RSB1
A12	GEA0/IO107RSB1
A13	GEC2/IO104RSB1
A14	IO100RSB1
A15	V _{CC}
A16	IO99RSB1
A17	IO96RSB1
A18	IO94RSB1
A19	IO91RSB1
A20	IO85RSB1
A21	IO79RSB1
A22	V _{CC}
A23	GDB2/IO71RSB1
A24	TDI
A25	TRST
A26	GDC1/IO61RSB0
A27	V _{CC}
A28	IO60RSB0
A29	GCC2/IO59RSB0
A30	GCA2/IO57RSB0
A31	GCA0/IO56RSB0
A32	GCB1/IO53RSB0
A33	IO49RSB0
A34	V _{CC}
A35	IO44RSB0
A36	GBA2/IO41RSB0

132-Pin QFN	
Pin Number	A3P125 Function
A37	GBB1/IO38RSB0
A38	GBC0/IO35RSB0
A39	V _{CC} B0
A40	IO28RSB0
A41	IO22RSB0
A42	IO18RSB0
A43	IO14RSB0
A44	IO11RSB0
A45	IO07RSB0
A46	V _{CC}
A47	GAC1/IO05RSB0
A48	GAB0/IO02RSB0
B1	IO68RSB1
B2	GAC2/IO131RSB1
B3	GND
B4	GFC0/IO125RSB1
B5	V _{COMPLF}
B6	GND
B7	GFB2/IO119RSB1
B8	IO116RSB1
B9	GND
B10	GEB0/IO109RSB1
B11	VMV1
B12	GEB2/IO105RSB1
B13	IO101RSB1
B14	GND
B15	IO98RSB1
B16	IO95RSB1
B17	GND
B18	IO87RSB1
B19	IO81RSB1
B20	GND
B21	GNDQ
B22	TMS
B23	TDO
B24	GDC0/IO62RSB0

132-Pin QFN	
Pin Number	A3P125 Function
B25	GND
B26	NC
B27	GCB2/IO58RSB0
B28	GND
B29	GCB0/IO54RSB0
B30	GCC1/IO51RSB0
B31	GND
B32	GBB2/IO43RSB0
B33	VMV0
B34	GBA0/IO39RSB0
B35	GBC1/IO36RSB0
B36	GND
B37	IO26RSB0
B38	IO21RSB0
B39	GND
B40	IO13RSB0
B41	IO08RSB0
B42	GND
B43	GAC0/IO04RSB0
B44	GNDQ
C1	GAA2/IO67RSB1
C2	IO132RSB1
C3	V _{CC}
C4	GFB1/IO124RSB1
C5	GFA0/IO122RSB1
C6	GFA2/IO120RSB1
C7	IO117RSB1
C8	V _{CC} B1
C9	GEA1/IO108RSB1
C10	GNDQ
C11	GEA2/IO106RSB1
C12	IO103RSB1
C13	V _{CC} B1
C14	IO97RSB1
C15	IO93RSB1
C16	IO89RSB1

132-Pin QFN	
Pin Number	A3P125 Function
C17	IO83RSB1
C18	V _{CC} B1
C19	TCK
C20	VMV1
C21	V _{PUMP}
C22	V _{JTAG}
C23	V _{CC} B0
C24	NC
C25	NC
C26	GCA1/IO55RSB0
C27	GCC0/IO52RSB0
C28	V _{CC} B0
C29	IO42RSB0
C30	GNDQ
C31	GBA1/IO40RSB0
C32	GBB0/IO37RSB0
C33	V _{CC}
C34	IO24RSB0
C35	IO19RSB0
C36	IO16RSB0
C37	IO10RSB0
C38	V _{CC} B0
C39	GAB1/IO03RSB0
C40	VMV0
D1	GND
D2	GND
D3	GND
D4	GND

132-Pin QFN	
Pin Number	A3P250 Function
A1	GAB2/IO117UPB3
A2	IO117VPB3
A3	V _{CC} B3
A4	GFC1/IO110PDB3
A5	GFB0/IO109NPB3
A6	V _{CC} PLF
A7	GFA1/IO108PPB3
A8	GFC2/IO105PPB3
A9	IO103NDB3
A10	V _{CC}
A11	GEA1/IO98PPB3
A12	GEA0/IO98NPB3
A13	GEC2/IO95RSB2
A14	IO91RSB2
A15	V _{CC}
A16	IO90RSB2
A17	IO87RSB2
A18	IO85RSB2
A19	IO82RSB2
A20	IO76RSB2
A21	IO70RSB2
A22	V _{CC}
A23	GDB2/IO62RSB2
A24	TDI
A25	TRST
A26	GDC1/IO58UDB1
A27	V _{CC}
A28	IO54NDB1
A29	IO52NDB1
A30	GCA2/IO51PPB1
A31	GCA0/IO50NPB1
A32	GCB1/IO49PDB1
A33	IO47NSB1
A34	V _{CC}
A35	IO41NPB1
A36	GBA2/IO41PPB1

132-Pin QFN	
Pin Number	A3P250 Function
A37	GBB1/IO38RSB0
A38	GBC0/IO35RSB0
A39	V _{CC} B0
A40	IO28RSB0
A41	IO22RSB0
A42	IO18RSB0
A43	IO14RSB0
A44	IO11RSB0
A45	IO07RSB0
A46	V _{CC}
A47	GAC1/IO05RSB0
A48	GAB0/IO02RSB0
B1	IO118VDB3
B2	GAC2/IO116UDB3
B3	GND
B4	GFC0/IO110NDB3
B5	V _{COMPLF}
B6	GND
B7	GFB2/IO106PSB3
B8	IO103PDB3
B9	GND
B10	GEB0/IO99NDB3
B11	VMV3
B12	GEB2/IO96RSB2
B13	IO92RSB2
B14	GND
B15	IO89RSB2
B16	IO86RSB2
B17	GND
B18	IO78RSB2
B19	IO72RSB2
B20	GND
B21	GNDQ
B22	TMS
B23	TDO
B24	GDC0/IO58VDB1

132-Pin QFN	
Pin Number	A3P250 Function
B25	GND
B26	IO54PDB1
B27	GCB2/IO52PDB1
B28	GND
B29	GCB0/IO49NDB1
B30	GCC1/IO48PDB1
B31	GND
B32	GBB2/IO42PDB1
B33	VMV1
B34	GBA0/IO39RSB0
B35	GBC1/IO36RSB0
B36	GND
B37	IO26RSB0
B38	IO21RSB0
B39	GND
B40	IO13RSB0
B41	IO08RSB0
B42	GND
B43	GAC0/IO04RSB0
B44	GNDQ
C1	GAA2/IO118UDB3
C2	IO116VDB3
C3	V _{CC}
C4	GFB1/IO109PPB3
C5	GFA0/IO108NPB3
C6	GFA2/IO107PSB3
C7	IO105NPB3
C8	V _{CC} B3
C9	GEB1/IO99PDB3
C10	GNDQ
C11	GEA2/IO97RSB2
C12	IO94RSB2
C13	V _{CC} B2
C14	IO88RSB2
C15	IO84RSB2
C16	IO80RSB2

132-Pin QFN	
Pin Number	A3P250 Function
C17	IO74RSB2
C18	V _{CC} B2
C19	TCK
C20	VMV2
C21	V _{PUMP}
C22	V _{JTAG}
C23	V _{CC} B1
C24	IO53NSB1
C25	IO51NPB1
C26	GCA1/IO50PPB1
C27	GCC0/IO48NDB1
C28	V _{CC} B1
C29	IO42NDB1
C30	GNDQ
C31	GBA1/IO40RSB0
C32	GBB0/IO37RSB0
C33	V _{CC}
C34	IO24RSB0
C35	IO19RSB0
C36	IO16RSB0
C37	IO10RSB0
C38	V _{CC} B0
C39	GAB1/IO03RSB0
C40	VMV0
D1	GND
D2	GND
D3	GND
D4	GND

100-Pin VQFP

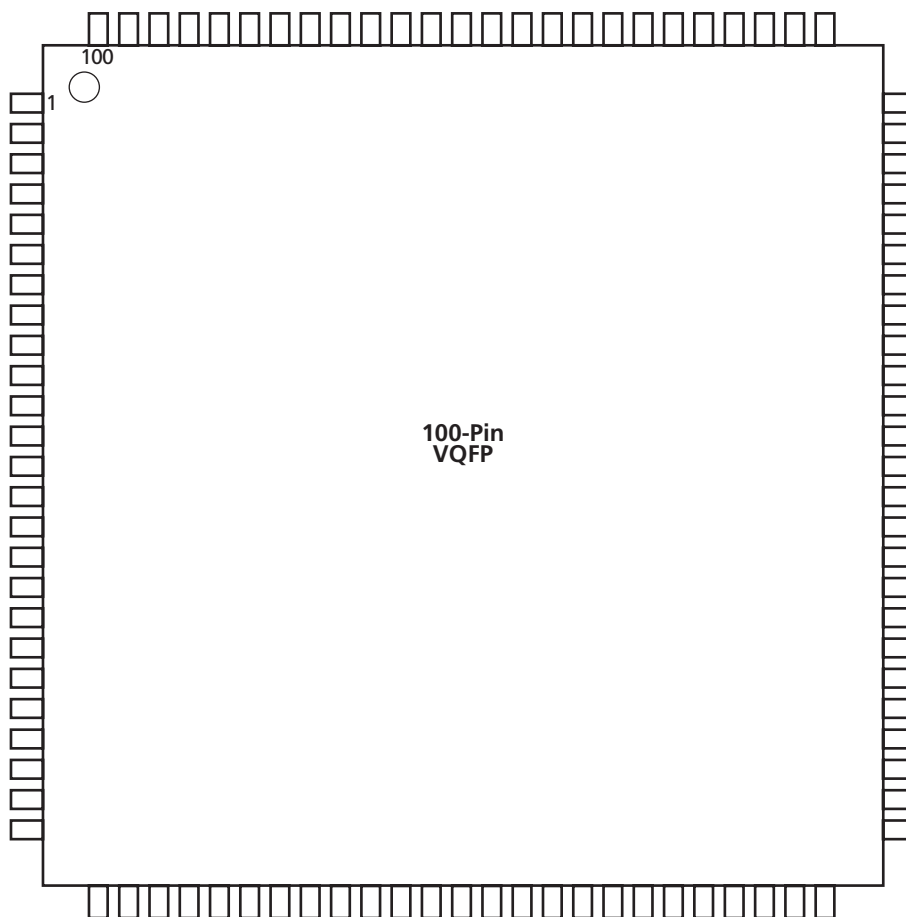

Note: This is the top view of the package.

Note

For Package Manufacturing and Environmental information, visit the Resource Center at <http://www.actel.com/products/solutions/package/docs.aspx>.

100-Pin VQFP		100-Pin VQFP		100-Pin VQFP	
Pin Number	A3P030 Function	Pin Number	A3P030 Function	Pin Number	A3P030 Function
1	GND	37	V _{CC}	73	IO27RSB0
2	IO82RSB1	38	GND	74	IO26RSB0
3	IO81RSB1	39	V _{CC} B1	75	IO25RSB0
4	IO80RSB1	40	IO49RSB1	76	IO24RSB0
5	IO79RSB1	41	IO47RSB1	77	IO23RSB0
6	IO78RSB1	42	IO46RSB1	78	IO22RSB0
7	IO77RSB1	43	IO45RSB1	79	IO21RSB0
8	IO76RSB1	44	IO44RSB1	80	IO20RSB0
9	GND	45	IO43RSB1	81	IO19RSB0
10	IO75RSB1	46	IO42RSB1	82	IO18RSB0
11	IO74RSB1	47	TCK	83	IO17RSB0
12	GECO/IO73RSB1	48	TDI	84	IO16RSB0
13	GEAO/IO72RSB1	49	TMS	85	IO15RSB0
14	GEBO/IO71RSB1	50	NC	86	IO14RSB0
15	IO70RSB1	51	GND	87	V _{CC} B0
16	IO69RSB1	52	V _{PUMP}	88	GND
17	V _{CC}	53	NC	89	V _{CC}
18	V _{CC} B1	54	TDO	90	IO12RSB0
19	IO68RSB1	55	TRST	91	IO10RSB0
20	IO67RSB1	56	V _{JTAG}	92	IO08RSB0
21	IO66RSB1	57	IO41RSB0	93	IO07RSB0
22	IO65RSB1	58	IO40RSB0	94	IO06RSB0
23	IO64RSB1	59	IO39RSB0	95	IO05RSB0
24	IO63RSB1	60	IO38RSB0	96	IO04RSB0
25	IO62RSB1	61	IO37RSB0	97	IO03RSB0
26	IO61RSB1	62	IO36RSB0	98	IO02RSB0
27	IO60RSB1	63	GDB0/IO34RSB0	99	IO01RSB0
28	IO59RSB1	64	GDA0/IO33RSB0	100	IO00RSB0
29	IO58RSB1	65	GDC0/IO32RSB0		
30	IO57RSB1	66	V _{CC} B0		
31	IO56RSB1	67	GND		
32	IO55RSB1	68	V _{CC}		
33	IO54RSB1	69	IO31RSB0		
34	IO53RSB1	70	IO30RSB0		
35	IO52RSB1	71	IO29RSB0		
36	IO51RSB1	72	IO28RSB0		

100-Pin VQFP	
Pin Number	A3P060 Function
1	GND
2	GAA2/IO51RSB1
3	IO52RSB1
4	GAB2/IO53RSB1
5	IO95RSB1
6	GAC2/IO94RSB1
7	IO93RSB1
8	IO92RSB1
9	GND
10	GFB1/IO87RSB1
11	GFB0/IO86RSB1
12	V _{COMPLF}
13	GFA0/IO85RSB1
14	V _{CCPLF}
15	GFA1/IO84RSB1
16	GFA2/IO83RSB1
17	V _{CC}
18	V _{CCIB1}
19	GEC1/IO77RSB1
20	GEB1/IO75RSB1
21	GEB0/IO74RSB1
22	GEA1/IO73RSB1
23	GEA0/IO72RSB1
24	VMV1
25	GNDQ
26	GEA2/IO71RSB1
27	GEB2/IO70RSB1
28	GEC2/IO69RSB1
29	IO68RSB1
30	IO67RSB1
31	IO66RSB1
32	IO65RSB1
33	IO64RSB1
34	IO63RSB1
35	IO62RSB1
36	IO61RSB1

100-Pin VQFP	
Pin Number	A3P060 Function
37	V _{CC}
38	GND
39	V _{CCIB1}
40	IO60RSB1
41	IO59RSB1
42	IO58RSB1
43	IO57RSB1
44	GDC2/IO56RSB1
45	GDB2/IO55RSB1
46	GDA2/IO54RSB1
47	TCK
48	TDI
49	TMS
50	VMV1
51	GND
52	V _{PUMP}
53	NC
54	TDO
55	TRST
56	V _{JTAG}
57	GDA1/IO49RSB0
58	GDC0/IO46RSB0
59	GDC1/IO45RSB0
60	GCC2/IO43RSB0
61	GCB2/IO42RSB0
62	GCA0/IO40RSB0
63	GCA1/IO39RSB0
64	GCC0/IO36RSB0
65	GCC1/IO35RSB0
66	V _{CCIB0}
67	GND
68	V _{CC}
69	IO31RSB0
70	GBC2/IO29RSB0
71	GBB2/IO27RSB0
72	IO26RSB0

100-Pin VQFP	
Pin Number	A3P060 Function
73	GBA2/IO25RSB0
74	VMV0
75	GNDQ
76	GBA1/IO24RSB0
77	GBA0/IO23RSB0
78	GBB1/IO22RSB0
79	GBB0/IO21RSB0
80	GBC1/IO20RSB0
81	GBC0/IO19RSB0
82	IO18RSB0
83	IO17RSB0
84	IO15RSB0
85	IO13RSB0
86	IO11RSB0
87	V _{CCIB0}
88	GND
89	V _{CC}
90	IO10RSB0
91	IO09RSB0
92	IO08RSB0
93	GAC1/IO07RSB0
94	GAC0/IO06RSB0
95	GAB1/IO05RSB0
96	GAB0/IO04RSB0
97	GAA1/IO03RSB0
98	GAA0/IO02RSB0
99	IO01RSB0
100	IO00RSB0

100-Pin VQFP	
Pin Number	A3P125 Function
1	GND
2	GAA2/IO67RSB1
3	IO68RSB1
4	GAB2/IO69RSB1
5	IO132RSB1
6	GAC2/IO131RSB1
7	IO130RSB1
8	IO129RSB1
9	GND
10	GFB1/IO124RSB1
11	GFB0/IO123RSB1
12	V _{COMPLF}
13	GFA0/IO122RSB1
14	V _{CCPLF}
15	GFA1/IO121RSB1
16	GFA2/IO120RSB1
17	V _{CC}
18	V _{CCIB1}
19	GEC0/IO111RSB1
20	GEB1/IO110RSB1
21	GEB0/IO109RSB1
22	GEA1/IO108RSB1
23	GEA0/IO107RSB1
24	VMV1
25	GNDQ
26	GEA2/IO106RSB1
27	GEB2/IO105RSB1
28	GEC2/IO104RSB1
29	IO102RSB1
30	IO100RSB1
31	IO99RSB1
32	IO97RSB1
33	IO96RSB1
34	IO95RSB1
35	IO94RSB1
36	IO93RSB1

100-Pin VQFP	
Pin Number	A3P125 Function
37	V _{CC}
38	GND
39	V _{CCIB1}
40	IO87RSB1
41	IO84RSB1
42	IO81RSB1
43	IO75RSB1
44	GDC2/IO72RSB1
45	GDB2/IO71RSB1
46	GDA2/IO70RSB1
47	TCK
48	TDI
49	TMS
50	VMV1
51	GND
52	V _{PUMP}
53	NC
54	TDO
55	TRST
56	V _{JTAG}
57	GDA1/IO65RSB0
58	GDC0/IO62RSB0
59	GDC1/IO61RSB0
60	GCC2/IO59RSB0
61	GCB2/IO58RSB0
62	GCA0/IO56RSB0
63	GCA1/IO55RSB0
64	GCC0/IO52RSB0
65	GCC1/IO51RSB0
66	V _{CCIB0}
67	GND
68	V _{CC}
69	IO47RSB0
70	GBC2/IO45RSB0
71	GGB2/IO43RSB0
72	IO42RSB0

100-Pin VQFP	
Pin Number	A3P125 Function
73	GBA2/IO41RSB0
74	VMV0
75	GNDQ
76	GBA1/IO40RSB0
77	GBA0/IO39RSB0
78	GGB1/IO38RSB0
79	GGB0/IO37RSB0
80	GBC1/IO36RSB0
81	GBC0/IO35RSB0
82	IO32RSB0
83	IO28RSB0
84	IO25RSB0
85	IO22RSB0
86	IO19RSB0
87	V _{CCIB0}
88	GND
89	V _{CC}
90	IO15RSB0
91	IO13RSB0
92	IO11RSB0
93	IO09RSB0
94	IO07RSB0
95	GAC1/IO05RSB0
96	GAC0/IO04RSB0
97	GAB1/IO03RSB0
98	GAB0/IO02RSB0
99	GAA1/IO01RSB0
100	GAA0/IO00RSB0

100-Pin VQFP	
Pin Number	A3P250 Function
1	GND
2	GAA2/IO118UDB3
3	IO118VDB3
4	GAB2/IO117UDB3
5	IO117VDB3
6	GAC2/IO116UDB3
7	IO116VDB3
8	IO112PSB3
9	GND
10	GFB1/IO109PDB3
11	GFB0/IO109NDB3
12	V _{COMPLF}
13	GFA0/IO108NPB3
14	V _{CCPLF}
15	GFA1/IO108PPB3
16	GFA2/IO107PSB3
17	V _{CC}
18	V _{CCIB3}
19	GFC2/IO105PSB3
20	GEC1/IO100PDB3
21	GEC0/IO100NDB3
22	GEA1/IO98PDB3
23	GEA0/IO98NDB3
24	VMV3
25	GNDQ
26	GEA2/IO97RSB2
27	GEB2/IO96RSB2
28	GEC2/IO95RSB2
29	IO93RSB2
30	IO92RSB2
31	IO91RSB2
32	IO90RSB2
33	IO88RSB2
34	IO86RSB2
35	IO85RSB2
36	IO84RSB2

100-Pin VQFP	
Pin Number	A3P250 Function
37	V _{CC}
38	GND
39	V _{CCIB2}
40	IO77RSB2
41	IO74RSB2
42	IO71RSB2
43	GDC2/IO63RSB2
44	GDB2/IO62RSB2
45	GDA2/IO61RSB2
46	GNDQ
47	TCK
48	TDI
49	TMS
50	VMV2
51	GND
52	V _{PUMP}
53	NC
54	TDO
55	TRST
56	V _{JTAG}
57	GDA1/IO60USB1
58	GDC0/IO58VDB1
59	GDC1/IO58UDB1
60	IO52NDB1
61	GCB2/IO52PDB1
62	GCA1/IO50PDB1
63	GCA0/IO50NDB1
64	GCC0/IO48NDB1
65	GCC1/IO48PDB1
66	V _{CCIB1}
67	GND
68	V _{CC}
69	IO43NDB1
70	GBC2/IO43PDB1
71	GBB2/IO42PSB1
72	IO41NDB1

100-Pin VQFP	
Pin Number	A3P250 Function
73	GBA2/IO41PDB1
74	VMV1
75	GNDQ
76	GBA1/IO40RSB0
77	GBA0/IO39RSB0
78	GBB1/IO38RSB0
79	GBB0/IO37RSB0
80	GBC1/IO36RSB0
81	GBC0/IO35RSB0
82	IO29RSB0
83	IO27RSB0
84	IO25RSB0
85	IO23RSB0
86	IO21RSB0
87	V _{CCIB0}
88	GND
89	V _{CC}
90	IO15RSB0
91	IO13RSB0
92	IO11RSB0
93	GAC1/IO05RSB0
94	GAC0/IO04RSB0
95	GAB1/IO03RSB0
96	GAB0/IO02RSB0
97	GAA1/IO01RSB0
98	GAA0/IO00RSB0
99	GNDQ
100	VMV0

144-Pin TQFP

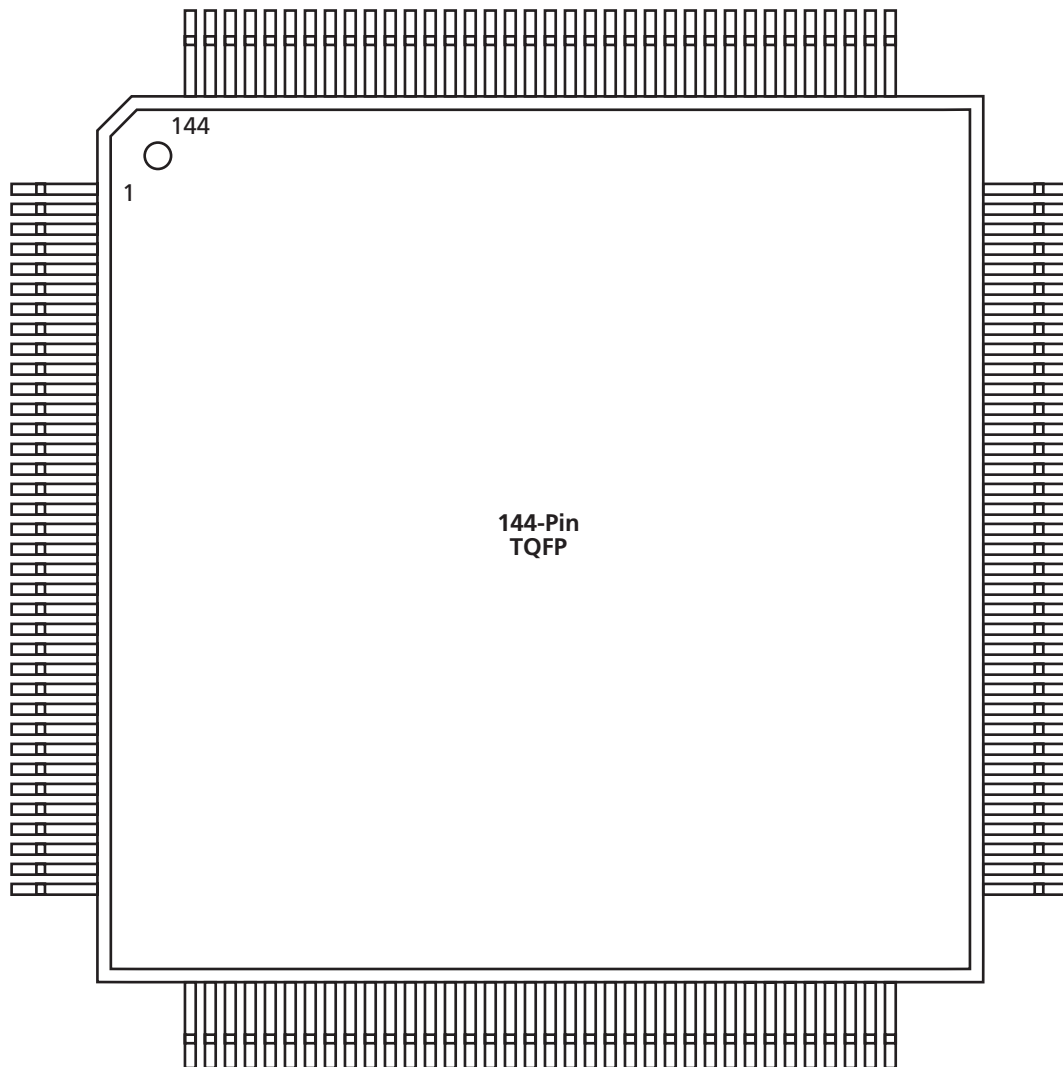

Note: This is the top view of the package.

Note

For Package Manufacturing and Environmental information, visit the Resource Center at <http://www.actel.com/products/solutions/package/docs.aspx>.

144-Pin TQFP	
Pin Number	A3P060 Function
1	GAA2/IO51RSB1
2	IO52RSB1
3	GAB2/IO53RSB1
4	IO95RSB1
5	GAC2/IO94RSB1
6	IO93RSB1
7	IO92RSB1
8	IO91RSB1
9	V _{CC}
10	GND
11	V _{CC} B1
12	IO90RSB1
13	GFC1/IO89RSB1
14	GFC0/IO88RSB1
15	GFB1/IO87RSB1
16	GFB0/IO86RSB1
17	V _{COMPLF}
18	GFA0/IO85RSB1
19	V _{CC} PLF
20	GFA1/IO84RSB1
21	GFA2/IO83RSB1
22	GFB2/IO82RSB1
23	GFC2/IO81RSB1
24	IO80RSB1
25	IO79RSB1
26	IO78RSB1
27	GND
28	V _{CC} B1
29	GEC1/IO77RSB1
30	GEC0/IO76RSB1
31	GEB1/IO75RSB1
32	GEB0/IO74RSB1
33	GEA1/IO73RSB1
34	GEA0/IO72RSB1
35	VMV1
36	GNDQ

144-Pin TQFP	
Pin Number	A3P060 Function
37	NC
38	GEA2/IO71RSB1
39	GEB2/IO70RSB1
40	GEC2/IO69RSB1
41	IO68RSB1
42	IO67RSB1
43	IO66RSB1
44	IO65RSB1
45	V _{CC}
46	GND
47	V _{CC} B1
48	NC
49	IO64RSB1
50	NC
51	IO63RSB1
52	NC
53	IO62RSB1
54	NC
55	IO61RSB1
56	NC
57	NC
58	IO60RSB1
59	IO59RSB1
60	IO58RSB1
61	IO57RSB1
62	NC
63	GND
64	NC
65	GDC2/IO56RSB1
66	GDB2/IO55RSB1
67	GDA2/IO54RSB1
68	GNDQ
69	TCK
70	TDI
71	TMS
72	VMV1

144-Pin TQFP	
Pin Number	A3P060 Function
73	V _{PUMP}
74	NC
75	TDO
76	TRST
77	V _{JTAG}
78	GDA0/IO50RSB0
79	GDB0/IO48RSB0
80	GDB1/IO47RSB0
81	V _{CC} B0
82	GND
83	IO44RSB0
84	GCC2/IO43RSB0
85	GCB2/IO42RSB0
86	GCA2/IO41RSB0
87	GCA0/IO40RSB0
88	GCA1/IO39RSB0
89	GCB0/IO38RSB0
90	GCB1/IO37RSB0
91	GCC0/IO36RSB0
92	GCC1/IO35RSB0
93	IO34RSB0
94	IO33RSB0
95	NC
96	NC
97	NC
98	V _{CC} B0
99	GND
100	V _{CC}
101	IO30RSB0
102	GBC2/IO29RSB0
103	IO28RSB0
104	GBB2/IO27RSB0
105	IO26RSB0
106	GBA2/IO25RSB0
107	VMV0
108	GNDQ

144-Pin TQFP	
Pin Number	A3P060 Function
109	NC
110	NC
111	GBA1/IO24RSB0
112	GBA0/IO23RSB0
113	GBB1/IO22RSB0
114	GBB0/IO21RSB0
115	GBC1/IO20RSB0
116	GBC0/IO19RSB0
117	V _{CCI} B0
118	GND
119	V _{CC}
120	IO18RSB0
121	IO17RSB0
122	IO16RSB0
123	IO15RSB0
124	IO14RSB0
125	IO13RSB0
126	IO12RSB0
127	IO11RSB0
128	NC
129	IO10RSB0
130	IO09RSB0
131	IO08RSB0
132	GAC1/IO07RSB0
133	GAC0/IO06RSB0
134	NC
135	GND
136	NC
137	GAB1/IO05RSB0
138	GAB0/IO04RSB0
139	GAA1/IO03RSB0
140	GAA0/IO02RSB0
141	IO01RSB0
142	IO00RSB0
143	GNDQ
144	VMV0

144-Pin TQFP	
Pin Number	A3P125 Function
1	GAA2/IO67RSB1
2	IO68RSB1
3	GAB2/IO69RSB1
4	IO132RSB1
5	GAC2/IO131RSB1
6	IO130RSB1
7	IO129RSB1
8	IO128RSB1
9	V _{CC}
10	GND
11	V _{CC1} B1
12	IO127RSB1
13	GFC1/IO126RSB1
14	GFC0/IO125RSB1
15	GFB1/IO124RSB1
16	GFB0/IO123RSB1
17	V _{COMPLF}
18	GFA0/IO122RSB1
19	V _{CCPLF}
20	GFA1/IO121RSB1
21	GFA2/IO120RSB1
22	GFB2/IO119RSB1
23	GFC2/IO118RSB1
24	IO117RSB1
25	IO116RSB1
26	IO115RSB1
27	GND
28	V _{CC1} B1
29	GEC1/IO112RSB1
30	GEC0/IO111RSB1
31	GEB1/IO110RSB1
32	GEB0/IO109RSB1
33	GEA1/IO108RSB1
34	GEA0/IO107RSB1
35	VMV1
36	GNDQ

144-Pin TQFP	
Pin Number	A3P125 Function
37	NC
38	GEA2/IO106RSB1
39	GEB2/IO105RSB1
40	GEC2/IO104RSB1
41	IO103RSB1
42	IO102RSB1
43	IO101RSB1
44	IO100RSB1
45	V _{CC}
46	GND
47	V _{CC1} B1
48	IO99RSB1
49	IO97RSB1
50	IO95RSB1
51	IO93RSB1
52	IO92RSB1
53	IO90RSB1
54	IO88RSB1
55	IO86RSB1
56	IO84RSB1
57	IO83RSB1
58	IO82RSB1
59	IO81RSB1
60	IO80RSB1
61	IO79RSB1
62	V _{CC}
63	GND
64	V _{CC1} B1
65	GDC2/IO72RSB1
66	GDB2/IO71RSB1
67	GDA2/IO70RSB1
68	GNDQ
69	TCK
70	TDI
71	TMS
72	VMV1

144-Pin TQFP	
Pin Number	A3P125 Function
73	V _{PUMP}
74	NC
75	TDO
76	TRST
77	V _{JTAG}
78	GDA0/IO66RSB0
79	GDB0/IO64RSB0
80	GDB1/IO63RSB0
81	V _{CC1} B0
82	GND
83	IO60RSB0
84	GCC2/IO59RSB0
85	GCB2/IO58RSB0
86	GCA2/IO57RSB0
87	GCA0/IO56RSB0
88	GCA1/IO55RSB0
89	GCB0/IO54RSB0
90	GCB1/IO53RSB0
91	GCC0/IO52RSB0
92	GCC1/IO51RSB0
93	IO50RSB0
94	IO49RSB0
95	NC
96	NC
97	NC
98	V _{CC1} B0
99	GND
100	V _{CC}
101	IO47RSB0
102	GBC2/IO45RSB0
103	IO44RSB0
104	GBB2/IO43RSB0
105	IO42RSB0
106	GBA2/IO41RSB0
107	VMV0
108	GNDQ

144-Pin TQFP	
Pin Number	A3P125 Function
109	GBA1/IO40RSB0
110	GBA0/IO39RSB0
111	GBB1/IO38RSB0
112	GBB0/IO37RSB0
113	GBC1/IO36RSB0
114	GBC0/IO35RSB0
115	IO34RSB0
116	IO33RSB0
117	V _{CCI} B0
118	GND
119	V _{CC}
120	IO29RSB0
121	IO28RSB0
122	IO27RSB0
123	IO25RSB0
124	IO23RSB0
125	IO21RSB0
126	IO19RSB0
127	IO17RSB0
128	IO16RSB0
129	IO14RSB0
130	IO12RSB0
131	IO10RSB0
132	IO08RSB0
133	IO06RSB0
134	V _{CCI} B0
135	GND
136	V _{CC}
137	GAC1/IO05RSB0
138	GAC0/IO04RSB0
139	GAB1/IO03RSB0
140	GAB0/IO02RSB0
141	GAA1/IO01RSB0
142	GAA0/IO00RSB0
143	GNDQ
144	VMV0

208-Pin PQFP

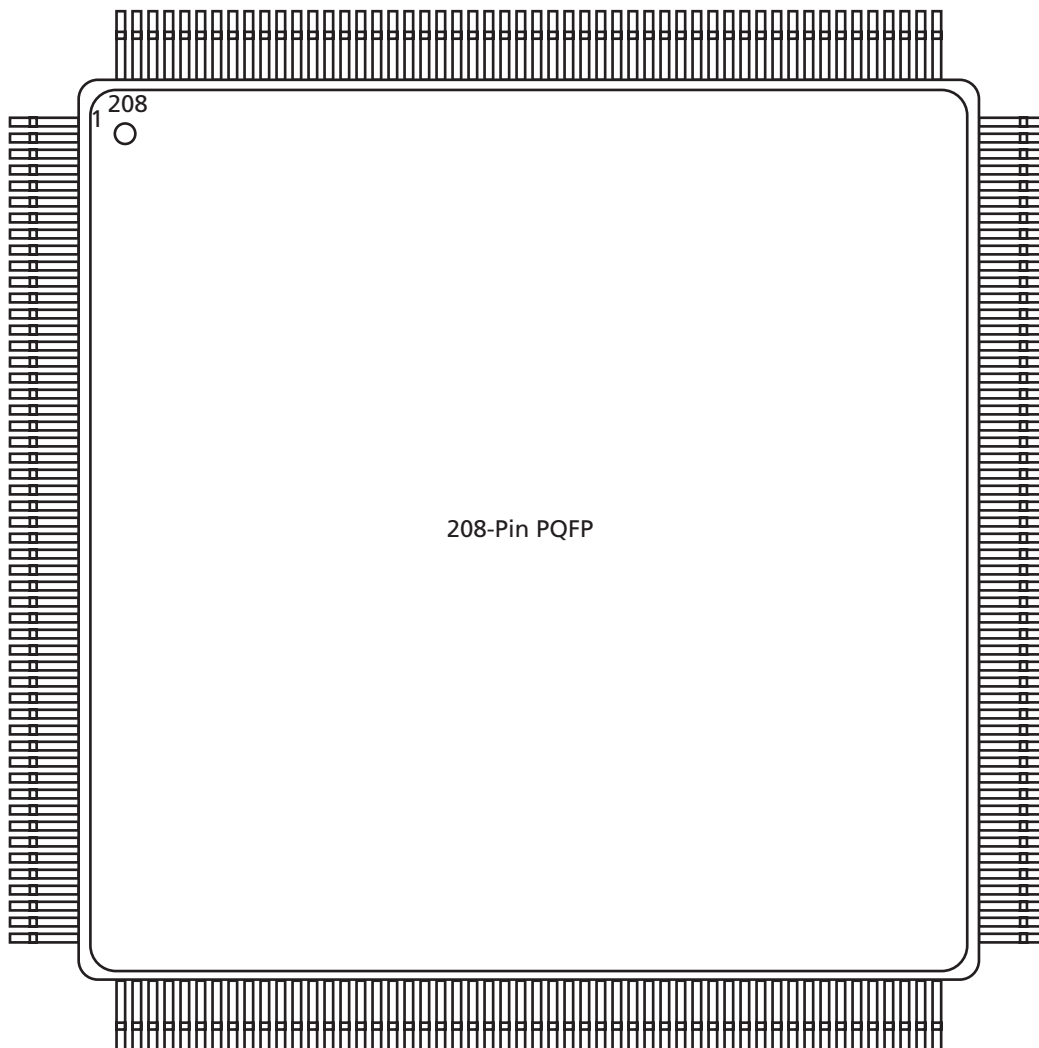

Note: This is the top view of the package.

Note

For Package Manufacturing and Environmental information, visit the Resource Center at <http://www.actel.com/products/solutions/package/docs.aspx>.

208-Pin PQFP		208-Pin PQFP		208-Pin PQFP	
Pin Number	A3P125 Function	Pin Number	A3P125 Function	Pin Number	A3P125 Function
1	GND	37	IO116RSB1	73	IO92RSB1
2	GAA2/IO67RSB1	38	IO115RSB1	74	IO91RSB1
3	IO68RSB1	39	NC	75	IO90RSB1
4	GAB2/IO69RSB1	40	V _{CC} B1	76	IO89RSB1
5	IO132RSB1	41	GND	77	IO88RSB1
6	GAC2/IO131RSB1	42	IO114RSB1	78	IO87RSB1
7	NC	43	IO113RSB1	79	IO86RSB1
8	NC	44	GEC1/IO112RSB1	80	IO85RSB1
9	IO130RSB1	45	GEC0/IO111RSB1	81	GND
10	IO129RSB1	46	GEB1/IO110RSB1	82	IO84RSB1
11	NC	47	GEB0/IO109RSB1	83	IO83RSB1
12	IO128RSB1	48	GEA1/IO108RSB1	84	IO82RSB1
13	NC	49	GEA0/IO107RSB1	85	IO81RSB1
14	NC	50	VMV1	86	IO80RSB1
15	NC	51	GNDQ	87	IO79RSB1
16	V _{CC}	52	GND	88	V _{CC}
17	GND	53	NC	89	V _{CC} B1
18	V _{CC} B1	54	NC	90	IO78RSB1
19	IO127RSB1	55	GEA2/IO106RSB1	91	IO77RSB1
20	NC	56	GEB2/IO105RSB1	92	IO76RSB1
21	GFC1/IO126RSB1	57	GEC2/IO104RSB1	93	IO75RSB1
22	GFC0/IO125RSB1	58	IO103RSB1	94	IO74RSB1
23	GFB1/IO124RSB1	59	IO102RSB1	95	IO73RSB1
24	GFB0/IO123RSB1	60	IO101RSB1	96	GDC2/IO72RSB1
25	V _{CC} PLF	61	IO100RSB1	97	GND
26	GFA0/IO122RSB1	62	V _{CC} B1	98	GDB2/IO71RSB1
27	V _{CC} PLF	63	IO99RSB1	99	GDA2/IO70RSB1
28	GFA1/IO121RSB1	64	IO98RSB1	100	GNDQ
29	GND	65	GND	101	TCK
30	GFA2/IO120RSB1	66	IO97RSB1	102	TDI
31	NC	67	IO96RSB1	103	TMS
32	GFB2/IO119RSB1	68	IO95RSB1	104	VMV1
33	NC	69	IO94RSB1	105	GND
34	GFC2/IO118RSB1	70	IO93RSB1	106	V _{PUMP}
35	IO117RSB1	71	V _{CC}	107	NC
36	NC	72	V _{CC} B1	108	TDO

208-Pin PQFP	
Pin Number	A3P125 Function
109	TRST
110	V _{JTAG}
111	GDA0/IO66RSB0
112	GDA1/IO65RSB0
113	GDB0/IO64RSB0
114	GDB1/IO63RSB0
115	GDC0/IO62RSB0
116	GDC1/IO61RSB0
117	NC
118	NC
119	NC
120	NC
121	NC
122	GND
123	V _{CC1} B0
124	NC
125	NC
126	V _{CC}
127	IO60RSB0
128	GCC2/IO59RSB0
129	GCB2/IO58RSB0
130	GND
131	GCA2/IO57RSB0
132	GCA0/IO56RSB0
133	GCA1/IO55RSB0
134	GCB0/IO54RSB0
135	GCB1/IO53RSB0
136	GCC0/IO52RSB0
137	GCC1/IO51RSB0
138	IO50RSB0
139	IO49RSB0
140	V _{CC1} B0
141	GND
142	V _{CC}
143	IO48RSB0
144	IO47RSB0

208-Pin PQFP	
Pin Number	A3P125 Function
145	IO46RSB0
146	NC
147	NC
148	NC
149	GBC2/IO45RSB0
150	IO44RSB0
151	GBB2/IO43RSB0
152	IO42RSB0
153	GBA2/IO41RSB0
154	VMV0
155	GNDQ
156	GND
157	NC
158	GBA1/IO40RSB0
159	GBA0/IO39RSB0
160	GBB1/IO38RSB0
161	GBB0/IO37RSB0
162	GND
163	GBC1/IO36RSB0
164	GBC0/IO35RSB0
165	IO34RSB0
166	IO33RSB0
167	IO32RSB0
168	IO31RSB0
169	IO30RSB0
170	V _{CC1} B0
171	V _{CC}
172	IO29RSB0
173	IO28RSB0
174	IO27RSB0
175	IO26RSB0
176	IO25RSB0
177	IO24RSB0
178	GND
179	IO23RSB0
180	IO22RSB0

208-Pin PQFP	
Pin Number	A3P125 Function
181	IO21RSB0
182	IO20RSB0
183	IO19RSB0
184	IO18RSB0
185	IO17RSB0
186	V _{CC1} B0
187	V _{CC}
188	IO16RSB0
189	IO15RSB0
190	IO14RSB0
191	IO13RSB0
192	IO12RSB0
193	IO11RSB0
194	IO10RSB0
195	GND
196	IO09RSB0
197	IO08RSB0
198	IO07RSB0
199	IO06RSB0
200	V _{CC1} B0
201	GAC1/IO05RSB0
202	GAC0/IO04RSB0
203	GAB1/IO03RSB0
204	GAB0/IO02RSB0
205	GAA1/IO01RSB0
206	GAA0/IO00RSB0
207	GNDQ
208	VMV0

208-Pin PQFP		208-Pin PQFP		208-Pin PQFP	
Pin Number	A3P250 Function	Pin Number	A3P250 Function	Pin Number	A3P250 Function
1	GND	37	IO104PDB3	73	IO83RSB2
2	GAA2/IO118UDB3	38	IO104NDB3	74	IO82RSB2
3	IO118VDB3	39	IO103PSB3	75	IO81RSB2
4	GAB2/IO117UDB3	40	V _{CC} B3	76	IO80RSB2
5	IO117VDB3	41	GND	77	IO79RSB2
6	GAC2/IO116UDB3	42	IO101PDB3	78	IO78RSB2
7	IO116VDB3	43	IO101NDB3	79	IO77RSB2
8	IO115UDB3	44	GEC1/IO100PDB3	80	IO76RSB2
9	IO115VDB3	45	GEC0/IO100NDB3	81	GND
10	IO114UDB3	46	GEB1/IO99PDB3	82	IO75RSB2
11	IO114VDB3	47	GEB0/IO99NDB3	83	IO74RSB2
12	IO113PDB3	48	GEA1/IO98PDB3	84	IO73RSB2
13	IO113NDB3	49	GEA0/IO98NDB3	85	IO72RSB2
14	IO112PDB3	50	VMV3	86	IO71RSB2
15	IO112NDB3	51	GNDQ	87	IO70RSB2
16	V _{CC}	52	GND	88	V _{CC}
17	GND	53	NC	89	V _{CC} B2
18	V _{CC} B3	54	NC	90	IO69RSB2
19	IO111PDB3	55	GEA2/IO97RSB2	91	IO68RSB2
20	IO111NDB3	56	GEB2/IO96RSB2	92	IO67RSB2
21	GFC1/IO110PDB3	57	GEC2/IO95RSB2	93	IO66RSB2
22	GFC0/IO110NDB3	58	IO94RSB2	94	IO65RSB2
23	GFB1/IO109PDB3	59	IO93RSB2	95	IO64RSB2
24	GFB0/IO109NDB3	60	IO92RSB2	96	GDC2/IO63RSB2
25	V _{COMPLF}	61	IO91RSB2	97	GND
26	GFA0/IO108NPB3	62	V _{CC} B2	98	GDB2/IO62RSB2
27	V _{CC} PLF	63	IO90RSB2	99	GDA2/IO61RSB2
28	GFA1/IO108PPB3	64	IO89RSB2	100	GNDQ
29	GND	65	GND	101	TCK
30	GFA2/IO107PDB3	66	IO88RSB2	102	TDI
31	IO107NDB3	67	IO87RSB2	103	TMS
32	GFB2/IO106PDB3	68	IO86RSB2	104	VMV2
33	IO106NDB3	69	IO85RSB2	105	GND
34	GFC2/IO105PDB3	70	IO84RSB2	106	V _{PUMP}
35	IO105NDB3	71	V _{CC}	107	NC
36	NC	72	V _{CC} B2	108	TDO

208-Pin PQFP	
Pin Number	A3P250 Function
109	TRST
110	V _{JTAG}
111	GDA0/IO60VDB1
112	GDA1/IO60UDB1
113	GDB0/IO59VDB1
114	GDB1/IO59UDB1
115	GDC0/IO58VDB1
116	GDC1/IO58UDB1
117	IO57VDB1
118	IO57UDB1
119	IO56NDB1
120	IO56PDB1
121	IO55RSB1
122	GND
123	V _{CC1} B1
124	NC
125	NC
126	V _{CC}
127	IO53NDB1
128	GCC2/IO53PDB1
129	GCB2/IO52PSB1
130	GND
131	GCA2/IO51PSB1
132	GCA1/IO50PDB1
133	GCA0/IO50NDB1
134	GCB0/IO49NDB1
135	GCB1/IO49PDB1
136	GCC0/IO48NDB1
137	GCC1/IO48PDB1
138	IO47NDB1
139	IO47PDB1
140	V _{CC1} B1
141	GND
142	V _{CC}
143	IO46RSB1
144	IO45NDB1

208-Pin PQFP	
Pin Number	A3P250 Function
145	IO45PDB1
146	IO44NDB1
147	IO44PDB1
148	IO43NDB1
149	GBC2/IO43PDB1
150	IO42NDB1
151	GBB2/IO42PDB1
152	IO41NDB1
153	GBA2/IO41PDB1
154	VMV1
155	GNDQ
156	GND
157	NC
158	GBA1/IO40RSB0
159	GBA0/IO39RSB0
160	GBB1/IO38RSB0
161	GBB0/IO37RSB0
162	GND
163	GBC1/IO36RSB0
164	GBC0/IO35RSB0
165	IO34RSB0
166	IO33RSB0
167	IO32RSB0
168	IO31RSB0
169	IO30RSB0
170	V _{CC1} B0
171	V _{CC}
172	IO29RSB0
173	IO28RSB0
174	IO27RSB0
175	IO26RSB0
176	IO25RSB0
177	IO24RSB0
178	GND
179	IO23RSB0
180	IO22RSB0

208-Pin PQFP	
Pin Number	A3P250 Function
181	IO21RSB0
182	IO20RSB0
183	IO19RSB0
184	IO18RSB0
185	IO17RSB0
186	V _{CC1} B0
187	V _{CC}
188	IO16RSB0
189	IO15RSB0
190	IO14RSB0
191	IO13RSB0
192	IO12RSB0
193	IO11RSB0
194	IO10RSB0
195	GND
196	IO09RSB0
197	IO08RSB0
198	IO07RSB0
199	IO06RSB0
200	V _{CC1} B0
201	GAC1/IO05RSB0
202	GAC0/IO04RSB0
203	GAB1/IO03RSB0
204	GAB0/IO02RSB0
205	GAA1/IO01RSB0
206	GAA0/IO00RSB0
207	GNDQ
208	VMV0

208-Pin PQFP		208-Pin PQFP		208-Pin PQFP	
Pin Number	A3P400 Function	Pin Number	A3P400 Function	Pin Number	A3P400 Function
1	GND	37	IO141PSB3	73	IO112RSB2
2	GAA2/IO155UDB3	38	IO140PDB3	74	IO111RSB2
3	IO155VDB3	39	IO140NDB3	75	IO110RSB2
4	GAB2/IO154UDB3	40	V _{CC} B3	76	IO109RSB2
5	IO154VDB3	41	GND	77	IO108RSB2
6	GAC2/IO153UDB3	42	IO138PDB3	78	IO107RSB2
7	IO153VDB3	43	IO138NDB3	79	IO106RSB2
8	IO152UDB3	44	GEC1/IO137PDB3	80	IO104RSB2
9	IO152VDB3	45	GEC0/IO137NDB3	81	GND
10	IO151UDB3	46	GEB1/IO136PDB3	82	IO102RSB2
11	IO151VDB3	47	GEB0/IO136NDB3	83	IO101RSB2
12	IO150PDB3	48	GEA1/IO135PDB3	84	IO100RSB2
13	IO150NDB3	49	GEA0/IO135NDB3	85	IO99RSB2
14	IO149PDB3	50	VMV3	86	IO98RSB2
15	IO149NDB3	51	GNDQ	87	IO97RSB2
16	V _{CC}	52	GND	88	V _{CC}
17	GND	53	VMV2	89	V _{CC} B2
18	V _{CC} B3	54	NC	90	IO94RSB2
19	IO148PDB3	55	GEA2/IO134RSB2	91	IO92RSB2
20	IO148NDB3	56	GEB2/IO133RSB2	92	IO90RSB2
21	GFC1/IO147PDB3	57	GEC2/IO132RSB2	93	IO88RSB2
22	GFC0/IO147NDB3	58	IO131RSB2	94	IO86RSB2
23	GFB1/IO146PDB3	59	IO130RSB2	95	IO84RSB2
24	GFB0/IO146NDB3	60	IO129RSB2	96	GDC2/IO82RSB2
25	V _{CC} COMPLF	61	IO128RSB2	97	GND
26	GFA0/IO145NPB3	62	V _{CC} B2	98	GDB2/IO81RSB2
27	V _{CC} PLF	63	IO125RSB2	99	GDA2/IO80RSB2
28	GFA1/IO145PPB3	64	IO123RSB2	100	GNDQ
29	GND	65	GND	101	TCK
30	GFA2/IO144PDB3	66	IO121RSB2	102	TDI
31	IO144NDB3	67	IO119RSB2	103	TMS
32	GFB2/IO143PDB3	68	IO117RSB2	104	VMV2
33	IO143NDB3	69	IO115RSB2	105	GND
34	GFC2/IO142PDB3	70	IO113RSB2	106	V _{PUMP}
35	IO142NDB3	71	V _{CC}	107	NC
36	NC	72	V _{CC} B2	108	TDO

208-Pin PQFP	
Pin Number	A3P400 Function
109	TRST
110	V _{JTAG}
111	GDA0/IO79VDB1
112	GDA1/IO79UDB1
113	GDB0/IO78VDB1
114	GDB1/IO78UDB1
115	GDC0/IO77VDB1
116	GDC1/IO77UDB1
117	IO76VDB1
118	IO76UDB1
119	IO75NDB1
120	IO75PDB1
121	IO74RSB1
122	GND
123	V _{CC1} B1
124	NC
125	NC
126	V _{CC}
127	IO72NDB1
128	GCC2/IO72PDB1
129	GCB2/IO71PSB1
130	GND
131	GCA2/IO70PSB1
132	GCA1/IO69PDB1
133	GCA0/IO69NDB1
134	GCB0/IO68NDB1
135	GCB1/IO68PDB1
136	GCC0/IO67NDB1
137	GCC1/IO67PDB1
138	IO66NDB1
139	IO66PDB1
140	V _{CC1} B1
141	GND
142	V _{CC}
143	IO65RSB1
144	IO64NDB1

208-Pin PQFP	
Pin Number	A3P400 Function
145	IO64PDB1
146	IO63NDB1
147	IO63PDB1
148	IO62NDB1
149	GBC2/IO62PDB1
150	IO61NDB1
151	GBB2/IO61PDB1
152	IO60NDB1
153	GBA2/IO60PDB1
154	VMV1
155	GNDQ
156	GND
157	VMV0
158	GBA1/IO59RSB0
159	GBA0/IO58RSB0
160	GBB1/IO57RSB0
161	GBB0/IO56RSB0
162	GND
163	GBC1/IO55RSB0
164	GBC0/IO54RSB0
165	IO52RSB0
166	IO49RSB0
167	IO46RSB0
168	IO43RSB0
169	IO40RSB0
170	V _{CC1} B0
171	V _{CC}
172	IO36RSB0
173	IO35RSB0
174	IO34RSB0
175	IO33RSB0
176	IO32RSB0
177	IO31RSB0
178	GND
179	IO29RSB0
180	IO28RSB0

208-Pin PQFP	
Pin Number	A3P400 Function
181	IO27RSB0
182	IO26RSB0
183	IO25RSB0
184	IO24RSB0
185	IO23RSB0
186	V _{CC1} B0
187	V _{CC}
188	IO21RSB0
189	IO20RSB0
190	IO19RSB0
191	IO18RSB0
192	IO17RSB0
193	IO16RSB0
194	IO15RSB0
195	GND
196	IO13RSB0
197	IO11RSB0
198	IO09RSB0
199	IO07RSB0
200	V _{CC1} B0
201	GAC1/IO05RSB0
202	GAC0/IO04RSB0
203	GAB1/IO03RSB0
204	GAB0/IO02RSB0
205	GAA1/IO01RSB0
206	GAA0/IO00RSB0
207	GNDQ
208	VMV0

208-Pin PQFP		208-Pin PQFP		208-Pin PQFP	
Pin Number	A3P600 Function	Pin Number	A3P600 Function	Pin Number	A3P600 Function
1	GND	37	IO152PDB3	73	IO120RSB2
2	GAA2/IO174PDB3	38	IO152NDB3	74	IO119RSB2
3	IO174NDB3	39	IO150PSB3	75	IO118RSB2
4	GAB2/IO173PDB3	40	V _{CC} B3	76	IO117RSB2
5	IO173NDB3	41	GND	77	IO116RSB2
6	GAC2/IO172PDB3	42	IO147PDB3	78	IO115RSB2
7	IO172NDB3	43	IO147NDB3	79	IO114RSB2
8	IO171PDB3	44	GEC1/IO146PDB3	80	IO112RSB2
9	IO171NDB3	45	GEC0/IO146NDB3	81	GND
10	IO170PDB3	46	GEB1/IO145PDB3	82	IO111RSB2
11	IO170NDB3	47	GEB0/IO145NDB3	83	IO110RSB2
12	IO169PDB3	48	GEA1/IO144PDB3	84	IO109RSB2
13	IO169NDB3	49	GEA0/IO144NDB3	85	IO108RSB2
14	IO168PDB3	50	VMV3	86	IO107RSB2
15	IO168NDB3	51	GNDQ	87	IO106RSB2
16	V _{CC}	52	GND	88	V _{CC}
17	GND	53	VMV2	89	V _{CC} B2
18	V _{CC} B3	54	GEA2/IO143RSB2	90	IO104RSB2
19	IO166PDB3	55	GEB2/IO142RSB2	91	IO102RSB2
20	IO166NDB3	56	GEC2/IO141RSB2	92	IO100RSB2
21	GFC1/IO164PDB3	57	IO140RSB2	93	IO98RSB2
22	GFC0/IO164NDB3	58	IO139RSB2	94	IO96RSB2
23	GFB1/IO163PDB3	59	IO138RSB2	95	IO92RSB2
24	GFB0/IO163NDB3	60	IO137RSB2	96	GDC2/IO91RSB2
25	V _{COMPLF}	61	IO136RSB2	97	GND
26	GFA0/IO162NPB3	62	V _{CC} B2	98	GDB2/IO90RSB2
27	V _{CC} PLF	63	IO135RSB2	99	GDA2/IO89RSB2
28	GFA1/IO162PPB3	64	IO133RSB2	100	GNDQ
29	GND	65	GND	101	TCK
30	GFA2/IO161PDB3	66	IO131RSB2	102	TDI
31	IO161NDB3	67	IO129RSB2	103	TMS
32	GFB2/IO160PDB3	68	IO127RSB2	104	VMV2
33	IO160NDB3	69	IO125RSB2	105	GND
34	GFC2/IO159PDB3	70	IO123RSB2	106	V _{PUMP}
35	IO159NDB3	71	V _{CC}	107	GNDQ
36	V _{CC}	72	V _{CC} B2	108	TDO

208-Pin PQFP		208-Pin PQFP		208-Pin PQFP	
Pin Number	A3P600 Function	Pin Number	A3P600 Function	Pin Number	A3P600 Function
109	TRST	145	IO64PDB1	181	IO27RSB0
110	V _{JTAG}	146	IO63NDB1	182	IO26RSB0
111	GDA0/IO88NDB1	147	IO63PDB1	183	IO25RSB0
112	GDA1/IO88PDB1	148	IO62NDB1	184	IO24RSB0
113	GDB0/IO87NDB1	149	GBC2/IO62PDB1	185	IO23RSB0
114	GDB1/IO87PDB1	150	IO61NDB1	186	V _{CCi} B0
115	GDC0/IO86NDB1	151	GBB2/IO61PDB1	187	V _{CC}
116	GDC1/IO86PDB1	152	IO60NDB1	188	IO20RSB0
117	IO84NDB1	153	GBA2/IO60PDB1	189	IO19RSB0
118	IO84PDB1	154	VMV1	190	IO18RSB0
119	IO82NDB1	155	GNDQ	191	IO17RSB0
120	IO82PDB1	156	GND	192	IO16RSB0
121	IO81PSB1	157	VMV0	193	IO14RSB0
122	GND	158	GBA1/IO59RSB0	194	IO12RSB0
123	V _{CCi} B1	159	GBA0/IO58RSB0	195	GND
124	IO77NDB1	160	GBB1/IO57RSB0	196	IO10RSB0
125	IO77PDB1	161	GBB0/IO56RSB0	197	IO09RSB0
126	NC	162	GND	198	IO08RSB0
127	IO74NDB1	163	GBC1/IO55RSB0	199	IO07RSB0
128	GCC2/IO74PDB1	164	GBC0/IO54RSB0	200	V _{CCi} B0
129	GCB2/IO73PSB1	165	IO52RSB0	201	GAC1/IO05RSB0
130	GND	166	IO50RSB0	202	GAC0/IO04RSB0
131	GCA2/IO72PSB1	167	IO48RSB0	203	GAB1/IO03RSB0
132	GCA1/IO71PDB1	168	IO46RSB0	204	GAB0/IO02RSB0
133	GCA0/IO71NDB1	169	IO44RSB0	205	GAA1/IO01RSB0
134	GCB0/IO70NDB1	170	V _{CCi} B0	206	GAA0/IO00RSB0
135	GCB1/IO70PDB1	171	V _{CC}	207	GNDQ
136	GCC0/IO69NDB1	172	IO36RSB0	208	VMV0
137	GCC1/IO69PDB1	173	IO35RSB0		
138	IO67NDB1	174	IO34RSB0		
139	IO67PDB1	175	IO33RSB0		
140	V _{CCi} B1	176	IO32RSB0		
141	GND	177	IO31RSB0		
142	V _{CC}	178	GND		
143	IO65PSB1	179	IO29RSB0		
144	IO64NDB1	180	IO28RSB0		

208-Pin PQFP		208-Pin PQFP		208-Pin PQFP	
Pin Number	A3P1000 Function	Pin Number	A3P1000 Function	Pin Number	A3P1000 Function
1	GND	37	IO199PDB3	73	IO162RSB2
2	GAA2/IO225PDB3	38	IO199NDB3	74	IO160RSB2
3	IO225NDB3	39	IO197PSB3	75	IO158RSB2
4	GAB2/IO224PDB3	40	V _{CC} B3	76	IO156RSB2
5	IO224NDB3	41	GND	77	IO154RSB2
6	GAC2/IO223PDB3	42	IO191PDB3	78	IO152RSB2
7	IO223NDB3	43	IO191NDB3	79	IO150RSB2
8	IO222PDB3	44	GEC1/IO190PDB3	80	IO148RSB2
9	IO222NDB3	45	GEC0/IO190NDB3	81	GND
10	IO220PDB3	46	GEB1/IO189PDB3	82	IO143RSB2
11	IO220NDB3	47	GEB0/IO189NDB3	83	IO141RSB2
12	IO218PDB3	48	GEA1/IO188PDB3	84	IO139RSB2
13	IO218NDB3	49	GEA0/IO188NDB3	85	IO137RSB2
14	IO216PDB3	50	VMV3	86	IO135RSB2
15	IO216NDB3	51	GNDQ	87	IO133RSB2
16	V _{CC}	52	GND	88	V _{CC}
17	GND	53	VMV2	89	V _{CC} B2
18	V _{CC} B3	54	GEA2/IO187RSB2	90	IO128RSB2
19	IO212PDB3	55	GEB2/IO186RSB2	91	IO126RSB2
20	IO212NDB3	56	GEC2/IO185RSB2	92	IO124RSB2
21	GFC1/IO209PDB3	57	IO184RSB2	93	IO122RSB2
22	GFC0/IO209NDB3	58	IO183RSB2	94	IO120RSB2
23	GFB1/IO208PDB3	59	IO182RSB2	95	IO118RSB2
24	GFB0/IO208NDB3	60	IO181RSB2	96	GDC2/IO116RSB2
25	V _{CC} PLF	61	IO180RSB2	97	GND
26	GFA0/IO207NPB3	62	V _{CC} B2	98	GDB2/IO115RSB2
27	V _{CC} PLF	63	IO178RSB2	99	GDA2/IO114RSB2
28	GFA1/IO207PPB3	64	IO176RSB2	100	GNDQ
29	GND	65	GND	101	TCK
30	GFA2/IO206PDB3	66	IO174RSB2	102	TDI
31	IO206NDB3	67	IO172RSB2	103	TMS
32	GFB2/IO205PDB3	68	IO170RSB2	104	VMV2
33	IO205NDB3	69	IO168RSB2	105	GND
34	GFC2/IO204PDB3	70	IO166RSB2	106	V _{PUMP}
35	IO204NDB3	71	V _{CC}	107	GNDQ
36	V _{CC}	72	V _{CC} B2	108	TDO

208-Pin PQFP	
Pin Number	A3P1000 Function
109	TRST
110	V _{JTAG}
111	GDA0/IO113NDB1
112	GDA1/IO113PDB1
113	GDB0/IO112NDB1
114	GDB1/IO112PDB1
115	GDC0/IO111NDB1
116	GDC1/IO111PDB1
117	IO109NDB1
118	IO109PDB1
119	IO106NDB1
120	IO106PDB1
121	IO104PSB1
122	GND
123	V _{CC1} B1
124	IO99NDB1
125	IO99PDB1
126	NC
127	IO96NDB1
128	GCC2/IO96PDB1
129	GCB2/IO95PSB1
130	GND
131	GCA2/IO94PSB1
132	GCA1/IO93PDB1
133	GCA0/IO93NDB1
134	GCB0/IO92NDB1
135	GCB1/IO92PDB1
136	GCC0/IO91NDB1
137	GCC1/IO91PDB1
138	IO88NDB1
139	IO88PDB1
140	V _{CC1} B1
141	GND
142	V _{CC}
143	IO86PSB1
144	IO84NDB1

208-Pin PQFP	
Pin Number	A3P1000 Function
145	IO84PDB1
146	IO82NDB1
147	IO82PDB1
148	IO80NDB1
149	GBC2/IO80PDB1
150	IO79NDB1
151	GBB2/IO79PDB1
152	IO78NDB1
153	GBA2/IO78PDB1
154	VMV1
155	GNDQ
156	GND
157	VMV0
158	GBA1/IO77RSB0
159	GBA0/IO76RSB0
160	GBB1/IO75RSB0
161	GBB0/IO74RSB0
162	GND
163	GBC1/IO73RSB0
164	GBC0/IO72RSB0
165	IO70RSB0
166	IO67RSB0
167	IO63RSB0
168	IO60RSB0
169	IO57RSB0
170	V _{CC1} B0
171	V _{CC}
172	IO54RSB0
173	IO51RSB0
174	IO48RSB0
175	IO45RSB0
176	IO42RSB0
177	IO40RSB0
178	GND
179	IO38RSB0
180	IO35RSB0

208-Pin PQFP	
Pin Number	A3P1000 Function
181	IO33RSB0
182	IO31RSB0
183	IO29RSB0
184	IO27RSB0
185	IO25RSB0
186	V _{CC1} B0
187	V _{CC}
188	IO22RSB0
189	IO20RSB0
190	IO18RSB0
191	IO16RSB0
192	IO15RSB0
193	IO14RSB0
194	IO13RSB0
195	GND
196	IO12RSB0
197	IO11RSB0
198	IO10RSB0
199	IO09RSB0
200	V _{CC1} B0
201	GAC1/IO05RSB0
202	GAC0/IO04RSB0
203	GAB1/IO03RSB0
204	GAB0/IO02RSB0
205	GAA1/IO01RSB0
206	GAA0/IO00RSB0
207	GNDQ
208	VMV0

144-Pin FBGA

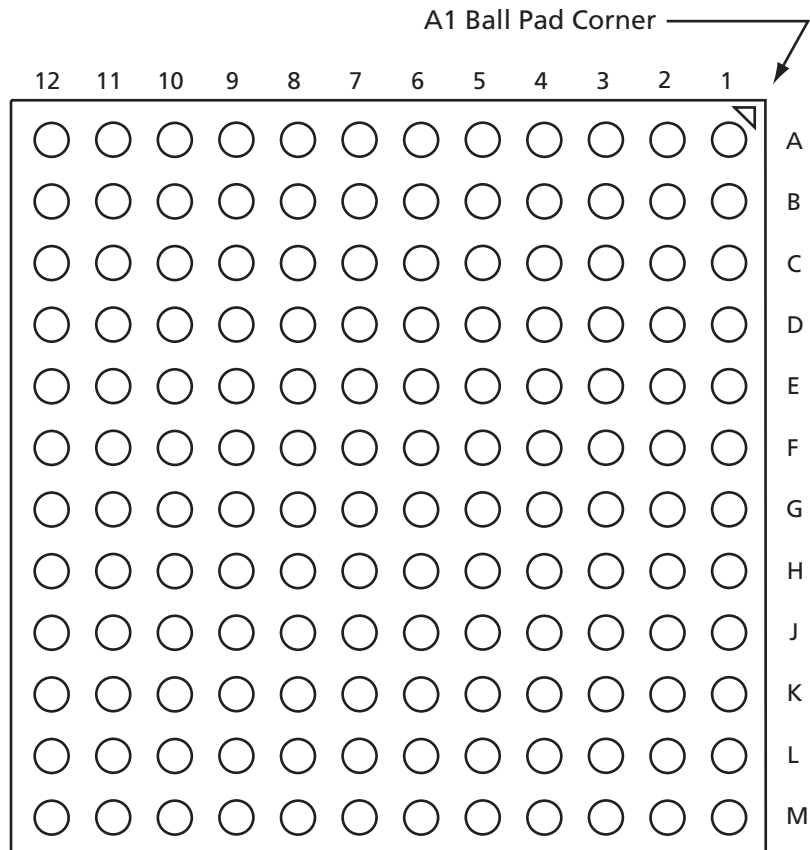

Note: This is the bottom view of the package.

Note

For Package Manufacturing and Environmental information, visit the Resource Center at <http://www.actel.com/products/solutions/package/docs.aspx>.

144-Pin FBGA	
Pin Number	A3P060 Function
A1	GNDQ
A2	VMV0
A3	GAB0/IO04RSB0
A4	GAB1/IO05RSB0
A5	IO08RSB0
A6	GND
A7	IO11RSB0
A8	V _{CC}
A9	IO16RSB0
A10	GBA0/IO23RSB0
A11	GBA1/IO24RSB0
A12	GNDQ
B1	GAB2/IO53RSB1
B2	GND
B3	GAA0/IO02RSB0
B4	GAA1/IO03RSB0
B5	IO00RSB0
B6	IO10RSB0
B7	IO12RSB0
B8	IO14RSB0
B9	GBB0/IO21RSB0
B10	GBB1/IO22RSB0
B11	GND
B12	VMV0
C1	IO95RSB1
C2	GFA2/IO83RSB1
C3	GAC2/IO94RSB1
C4	V _{CC}
C5	IO01RSB0
C6	IO09RSB0
C7	IO13RSB0
C8	IO15RSB0
C9	IO17RSB0
C10	GBA2/IO25RSB0
C11	IO26RSB0
C12	GBC2/IO29RSB0

144-Pin FBGA	
Pin Number	A3P060 Function
D1	IO91RSB1
D2	IO92RSB1
D3	IO93RSB1
D4	GAA2/IO51RSB1
D5	GAC0/IO06RSB0
D6	GAC1/IO07RSB0
D7	GBC0/IO19RSB0
D8	GBC1/IO20RSB0
D9	GBB2/IO27RSB0
D10	IO18RSB0
D11	IO28RSB0
D12	GCB1/IO37RSB0
E1	V _{CC}
E2	GFC0/IO88RSB1
E3	GFC1/IO89RSB1
E4	V _{CC} B1
E5	IO52RSB1
E6	V _{CC} B0
E7	V _{CC} B0
E8	GCC1/IO35RSB0
E9	V _{CC} B0
E10	V _{CC}
E11	GCA0/IO40RSB0
E12	IO30RSB0
F1	GFB0/IO86RSB1
F2	V _{COMPLF}
F3	GFB1/IO87RSB1
F4	IO90RSB1
F5	GND
F6	GND
F7	GND
F8	GCC0/IO36RSB0
F9	GCB0/IO38RSB0
F10	GND
F11	GCA1/IO39RSB0
F12	GCA2/IO41RSB0

144-Pin FBGA	
Pin Number	A3P060 Function
G1	GFA1/IO84RSB1
G2	GND
G3	V _{CC} PLF
G4	GFA0/IO85RSB1
G5	GND
G6	GND
G7	GND
G8	GDC1/IO45RSB0
G9	IO32RSB0
G10	GCC2/IO43RSB0
G11	IO31RSB0
G12	GCB2/IO42RSB0
H1	V _{CC}
H2	GFB2/IO82RSB1
H3	GFC2/IO81RSB1
H4	GEC1/IO77RSB1
H5	V _{CC}
H6	IO34RSB0
H7	IO44RSB0
H8	GDB2/IO55RSB1
H9	GDC0/IO46RSB0
H10	V _{CC} B0
H11	IO33RSB0
H12	V _{CC}
J1	GEB1/IO75RSB1
J2	IO78RSB1
J3	V _{CC} B1
J4	GEC0/IO76RSB1
J5	IO79RSB1
J6	IO80RSB1
J7	V _{CC}
J8	TCK
J9	GDA2/IO54RSB1
J10	TDO
J11	GDA1/IO49RSB0
J12	GDB1/IO47RSB0

144-Pin FBGA	
Pin Number	A3P060 Function
K1	GEB0/IO74RSB1
K2	GEA1/IO73RSB1
K3	GEA0/IO72RSB1
K4	GEA2/IO71RSB1
K5	IO65RSB1
K6	IO64RSB1
K7	GND
K8	IO57RSB1
K9	GDC2/IO56RSB1
K10	GND
K11	GDA0/IO50RSB0
K12	GDB0/IO48RSB0
L1	GND
L2	VMV1
L3	GEB2/IO70RSB1
L4	IO67RSB1
L5	V _{CC} B1
L6	IO62RSB1
L7	IO59RSB1
L8	IO58RSB1
L9	TMS
L10	V _{JTAG}
L11	VMV1
L12	TRST
M1	GNDQ
M2	GEC2/IO69RSB1
M3	IO68RSB1
M4	IO66RSB1
M5	IO63RSB1
M6	IO61RSB1
M7	IO60RSB1
M8	NC
M9	TDI
M10	V _{CC} B1
M11	V _{PUMP}
M12	GNDQ

144-Pin FBGA	
Pin Number	A3P125 Function
A1	GNDQ
A2	VMV0
A3	GAB0/IO02RSB0
A4	GAB1/IO03RSB0
A5	IO11RSB0
A6	GND
A7	IO18RSB0
A8	V _{CC}
A9	IO25RSB0
A10	GBA0/IO39RSB0
A11	GBA1/IO40RSB0
A12	GNDQ
B1	GAB2/IO69RSB1
B2	GND
B3	GAA0/IO00RSB0
B4	GAA1/IO01RSB0
B5	IO08RSB0
B6	IO14RSB0
B7	IO19RSB0
B8	IO22RSB0
B9	GBB0/IO37RSB0
B10	GBB1/IO38RSB0
B11	GND
B12	VMV0
C1	IO132RSB1
C2	GFA2/IO120RSB1
C3	GAC2/IO131RSB1
C4	V _{CC}
C5	IO10RSB0
C6	IO12RSB0
C7	IO21RSB0
C8	IO24RSB0
C9	IO27RSB0
C10	GBA2/IO41RSB0
C11	IO42RSB0
C12	GBC2/IO45RSB0

144-Pin FBGA	
Pin Number	A3P125 Function
D1	IO128RSB1
D2	IO129RSB1
D3	IO130RSB1
D4	GAA2/IO67RSB1
D5	GAC0/IO04RSB0
D6	GAC1/IO05RSB0
D7	GBC0/IO35RSB0
D8	GBC1/IO36RSB0
D9	GBB2/IO43RSB0
D10	IO28RSB0
D11	IO44RSB0
D12	GCB1/IO53RSB0
E1	V _{CC}
E2	GFC0/IO125RSB1
E3	GFC1/IO126RSB1
E4	V _{CC} B1
E5	IO68RSB1
E6	V _{CC} B0
E7	V _{CC} B0
E8	GCC1/IO51RSB0
E9	V _{CC} B0
E10	V _{CC}
E11	GCA0/IO56RSB0
E12	IO46RSB0
F1	GFB0/IO123RSB1
F2	V _{CC} COMPLF
F3	GFB1/IO124RSB1
F4	IO127RSB1
F5	GND
F6	GND
F7	GND
F8	GCC0/IO52RSB0
F9	GCB0/IO54RSB0
F10	GND
F11	GCA1/IO55RSB0
F12	GCA2/IO57RSB0

144-Pin FBGA	
Pin Number	A3P125 Function
G1	GFA1/IO121RSB1
G2	GND
G3	V _{CC} PLF
G4	GFA0/IO122RSB1
G5	GND
G6	GND
G7	GND
G8	GDC1/IO61RSB0
G9	IO48RSB0
G10	GCC2/IO59RSB0
G11	IO47RSB0
G12	GCB2/IO58RSB0
H1	V _{CC}
H2	GFB2/IO119RSB1
H3	GFC2/IO118RSB1
H4	GEC1/IO112RSB1
H5	V _{CC}
H6	IO50RSB0
H7	IO60RSB0
H8	GDB2/IO71RSB1
H9	GDC0/IO62RSB0
H10	V _{CC} B0
H11	IO49RSB0
H12	V _{CC}
J1	GEB1/IO110RSB1
J2	IO115RSB1
J3	V _{CC} B1
J4	GEC0/IO111RSB1
J5	IO116RSB1
J6	IO117RSB1
J7	V _{CC}
J8	TCK
J9	GDA2/IO70RSB1
J10	TDO
J11	GDA1/IO65RSB0
J12	GDB1/IO63RSB0

144-Pin FBGA	
Pin Number	A3P125 Function
K1	GEB0/IO109RSB1
K2	GEA1/IO108RSB1
K3	GEA0/IO107RSB1
K4	GEA2/IO106RSB1
K5	IO100RSB1
K6	IO98RSB1
K7	GND
K8	IO73RSB1
K9	GDC2/IO72RSB1
K10	GND
K11	GDA0/IO66RSB0
K12	GDB0/IO64RSB0
L1	GND
L2	VMV1
L3	GEB2/IO105RSB1
L4	IO102RSB1
L5	V _{CCI} B1
L6	IO95RSB1
L7	IO85RSB1
L8	IO74RSB1
L9	TMS
L10	V _{JTAG}
L11	VMV1
L12	TRST
M1	GNDQ
M2	GEC2/IO104RSB1
M3	IO103RSB1
M4	IO101RSB1
M5	IO97RSB1
M6	IO94RSB1
M7	IO86RSB1
M8	IO75RSB1
M9	TDI
M10	V _{CCI} B1
M11	V _{PUMP}
M12	GNDQ

144-Pin FBGA	
Pin Number	A3P250 Function
A1	GNDQ
A2	VMV0
A3	GAB0/IO02RSB0
A4	GAB1/IO03RSB0
A5	IO16RSB0
A6	GND
A7	IO29RSB0
A8	V _{CC}
A9	IO33RSB0
A10	GBA0/IO39RSB0
A11	GBA1/IO40RSB0
A12	GNDQ
B1	GAB2/IO117UDB3
B2	GND
B3	GAA0/IO00RSB0
B4	GAA1/IO01RSB0
B5	IO14RSB0
B6	IO19RSB0
B7	IO22RSB0
B8	IO30RSB0
B9	GBB0/IO37RSB0
B10	GBB1/IO38RSB0
B11	GND
B12	VMV1
C1	IO117VDB3
C2	GFA2/IO107PPB3
C3	GAC2/IO116UDB3
C4	V _{CC}
C5	IO12RSB0
C6	IO17RSB0
C7	IO24RSB0
C8	IO31RSB0
C9	IO34RSB0
C10	GBA2/IO41PDB1
C11	IO41NDB1
C12	GBC2/IO43PPB1

144-Pin FBGA	
Pin Number	A3P250 Function
D1	IO112NDB3
D2	IO112PDB3
D3	IO116VDB3
D4	GAA2/IO118UPB3
D5	GAC0/IO04RSB0
D6	GAC1/IO05RSB0
D7	GBC0/IO35RSB0
D8	GBC1/IO36RSB0
D9	GBB2/IO42PDB1
D10	IO42NDB1
D11	IO43NPB1
D12	GCB1/IO49PPB1
E1	V _{CC}
E2	GFC0/IO110NDB3
E3	GFC1/IO110PDB3
E4	V _{CC} B3
E5	IO118VPB3
E6	V _{CC} B0
E7	V _{CC} B0
E8	GCC1/IO48PDB1
E9	V _{CC} B1
E10	V _{CC}
E11	GCA0/IO50NDB1
E12	IO51NDB1
F1	GFB0/IO109NPB3
F2	V _{CC} COMPLF
F3	GFB1/IO109PPB3
F4	IO107NPB3
F5	GND
F6	GND
F7	GND
F8	GCC0/IO48NDB1
F9	GCB0/IO49NPB1
F10	GND
F11	GCA1/IO50PDB1
F12	GCA2/IO51PDB1

144-Pin FBGA	
Pin Number	A3P250 Function
G1	GFA1/IO108PPB3
G2	GND
G3	V _{CC} PLF
G4	GFA0/IO108NPB3
G5	GND
G6	GND
G7	GND
G8	GDC1/IO58UPB1
G9	IO53NDB1
G10	GCC2/IO53PDB1
G11	IO52NDB1
G12	GCB2/IO52PDB1
H1	V _{CC}
H2	GFB2/IO106PDB3
H3	GFC2/IO105PSB3
H4	GEC1/IO100PDB3
H5	V _{CC}
H6	IO79RSB2
H7	IO65RSB2
H8	GDB2/IO62RSB2
H9	GDC0/IO58VPB1
H10	V _{CC} B1
H11	IO54PSB1
H12	V _{CC}
J1	GEB1/IO99PDB3
J2	IO106NDB3
J3	V _{CC} B3
J4	GEC0/IO100NDB3
J5	IO88RSB2
J6	IO81RSB2
J7	V _{CC}
J8	TCK
J9	GDA2/IO61RSB2
J10	TDO
J11	GDA1/IO60UDB1
J12	GDB1/IO59UDB1

144-Pin FBGA	
Pin Number	A3P250 Function
K1	GEB0/IO99NDB3
K2	GEA1/IO98PDB3
K3	GEA0/IO98NDB3
K4	GEA2/IO97RSB2
K5	IO90RSB2
K6	IO84RSB2
K7	GND
K8	IO66RSB2
K9	GDC2/IO63RSB2
K10	GND
K11	GDA0/IO60VDB1
K12	GDB0/IO59VDB1
L1	GND
L2	VMV3
L3	GEB2/IO96RSB2
L4	IO91RSB2
L5	V _{CCI} B2
L6	IO82RSB2
L7	IO80RSB2
L8	IO72RSB2
L9	TMS
L10	V _{JTAG}
L11	VMV2
L12	TRST
M1	GNDQ
M2	GEC2/IO95RSB2
M3	IO92RSB2
M4	IO89RSB2
M5	IO87RSB2
M6	IO85RSB2
M7	IO78RSB2
M8	IO76RSB2
M9	TDI
M10	V _{CCI} B2
M11	V _{PUMP}
M12	GNDQ

144-Pin FBGA	
Pin Number	A3P400 Function
A1	GNDQ
A2	VMV0
A3	GAB0/IO02RSB0
A4	GAB1/IO03RSB0
A5	IO16RSB0
A6	GND
A7	IO30RSB0
A8	V _{CC}
A9	IO34RSB0
A10	GBA0/IO58RSB0
A11	GBA1/IO59RSB0
A12	GNDQ
B1	GAB2/IO154UDB3
B2	GND
B3	GAA0/IO00RSB0
B4	GAA1/IO01RSB0
B5	IO14RSB0
B6	IO19RSB0
B7	IO23RSB0
B8	IO31RSB0
B9	GBB0/IO56RSB0
B10	GBB1/IO57RSB0
B11	GND
B12	VMV1
C1	IO154VDB3
C2	GFA2/IO144PPB3
C3	GAC2/IO153UDB3
C4	V _{CC}
C5	IO12RSB0
C6	IO17RSB0
C7	IO25RSB0
C8	IO32RSB0
C9	IO53RSB0
C10	GBA2/IO60PDB1
C11	IO60NDB1
C12	GBC2/IO62PPB1

144-Pin FBGA	
Pin Number	A3P400 Function
D1	IO149NDB3
D2	IO149PDB3
D3	IO153VDB3
D4	GAA2/IO155UPB3
D5	GAC0/IO04RSB0
D6	GAC1/IO05RSB0
D7	GBC0/IO54RSB0
D8	GBC1/IO55RSB0
D9	GBB2/IO61PDB1
D10	IO61NDB1
D11	IO62NPB1
D12	GCB1/IO68PPB1
E1	V _{CC}
E2	GFC0/IO147NDB3
E3	GFC1/IO147PDB3
E4	V _{CC} B3
E5	IO155VPB3
E6	V _{CC} B0
E7	V _{CC} B0
E8	GCC1/IO67PDB1
E9	V _{CC} B1
E10	V _{CC}
E11	GCA0/IO69NDB1
E12	IO70NDB1
F1	GFB0/IO146NPB3
F2	V _{CC} OMPLF
F3	GFB1/IO146PPB3
F4	IO144NPB3
F5	GND
F6	GND
F7	GND
F8	GCC0/IO67NDB1
F9	GCB0/IO68NPB1
F10	GND
F11	GCA1/IO69PDB1
F12	GCA2/IO70PDB1

144-Pin FBGA	
Pin Number	A3P400 Function
G1	GFA1/IO145PPB3
G2	GND
G3	V _{CC} PLF
G4	GFA0/IO145NPB3
G5	GND
G6	GND
G7	GND
G8	GDC1/IO77UPB1
G9	IO72NDB1
G10	GCC2/IO72PDB1
G11	IO71NDB1
G12	GCB2/IO71PDB1
H1	V _{CC}
H2	GFB2/IO143PDB3
H3	GFC2/IO142PSB3
H4	GEC1/IO137PDB3
H5	V _{CC}
H6	IO75PDB1
H7	IO75NDB1
H8	GDB2/IO81RSB2
H9	GDC0/IO77VPB1
H10	V _{CC} B1
H11	IO73PSB1
H12	V _{CC}
J1	GEB1/IO136PDB3
J2	IO143NDB3
J3	V _{CC} B3
J4	GEC0/IO137NDB3
J5	IO125RSB2
J6	IO116RSB2
J7	V _{CC}
J8	TCK
J9	GDA2/IO80RSB2
J10	TDO
J11	GDA1/IO79UDB1
J12	GDB1/IO78UDB1

144-Pin FBGA	
Pin Number	A3P400 Function
K1	GEB0/IO136NDB3
K2	GEA1/IO135PDB3
K3	GEA0/IO135NDB3
K4	GEA2/IO134RSB2
K5	IO127RSB2
K6	IO121RSB2
K7	GND
K8	IO104RSB2
K9	GDC2/IO82RSB2
K10	GND
K11	GDA0/IO79VDB1
K12	GDB0/IO78VDB1
L1	GND
L2	VMV3
L3	GEB2/IO133RSB2
L4	IO128RSB2
L5	V _{CC} B2
L6	IO119RSB2
L7	IO114RSB2
L8	IO110RSB2
L9	TMS
L10	V _{JTAG}
L11	VMV2
L12	TRST
M1	GNDQ
M2	GEC2/IO132RSB2
M3	IO129RSB2
M4	IO126RSB2
M5	IO124RSB2
M6	IO122RSB2
M7	IO117RSB2
M8	IO115RSB2
M9	TDI
M10	V _{CC} B2
M11	V _{PUMP}
M12	GNDQ

144-Pin FBGA	
Pin Number	A3P600 Function
A1	GNDQ
A2	VMV0
A3	GAB0/IO02RSB0
A4	GAB1/IO03RSB0
A5	IO10RSB0
A6	GND
A7	IO34RSB0
A8	V _{CC}
A9	IO50RSB0
A10	GBA0/IO58RSB0
A11	GBA1/IO59RSB0
A12	GNDQ
B1	GAB2/IO173PDB3
B2	GND
B3	GAA0/IO00RSB0
B4	GAA1/IO01RSB0
B5	IO13RSB0
B6	IO19RSB0
B7	IO31RSB0
B8	IO39RSB0
B9	GBB0/IO56RSB0
B10	GBB1/IO57RSB0
B11	GND
B12	VMV1
C1	IO173NDB3
C2	GFA2/IO161PPB3
C3	GAC2/IO172PDB3
C4	V _{CC}
C5	IO16RSB0
C6	IO25RSB0
C7	IO28RSB0
C8	IO42RSB0
C9	IO45RSB0
C10	GBA2/IO60PDB1
C11	IO60NDB1
C12	GBC2/IO62PPB1

144-Pin FBGA	
Pin Number	A3P600 Function
D1	IO169PDB3
D2	IO169NDB3
D3	IO172NDB3
D4	GAA2/IO174PPB3
D5	GAC0/IO04RSB0
D6	GAC1/IO05RSB0
D7	GBC0/IO54RSB0
D8	GBC1/IO55RSB0
D9	GBB2/IO61PDB1
D10	IO61NDB1
D11	IO62NPB1
D12	GCB1/IO70PPB1
E1	V _{CC}
E2	GFC0/IO164NDB3
E3	GFC1/IO164PDB3
E4	V _{CC} B3
E5	IO174NPB3
E6	V _{CC} B0
E7	V _{CC} B0
E8	GCC1/IO69PDB1
E9	V _{CC} B1
E10	V _{CC}
E11	GCA0/IO71NDB1
E12	IO72NDB1
F1	GFB0/IO163NPB3
F2	V _{COMPLF}
F3	GFB1/IO163PPB3
F4	IO161NPB3
F5	GND
F6	GND
F7	GND
F8	GCC0/IO69NDB1
F9	GCB0/IO70NPB1
F10	GND
F11	GCA1/IO71PDB1
F12	GCA2/IO72PDB1

144-Pin FBGA	
Pin Number	A3P600 Function
G1	GFA1/IO162PPB3
G2	GND
G3	V _{CC} PLF
G4	GFA0/IO162NPB3
G5	GND
G6	GND
G7	GND
G8	GDC1/IO86PPB1
G9	IO74NDB1
G10	GCC2/IO74PDB1
G11	IO73NDB1
G12	GCB2/IO73PDB1
H1	V _{CC}
H2	GFB2/IO160PDB3
H3	GFC2/IO159PSB3
H4	GEC1/IO146PDB3
H5	V _{CC}
H6	IO80PDB1
H7	IO80NDB1
H8	GDB2/IO90RSB2
H9	GDC0/IO86NPB1
H10	V _{CC} B1
H11	IO84PSB1
H12	V _{CC}
J1	GEB1/IO145PDB3
J2	IO160NDB3
J3	V _{CC} B3
J4	GEC0/IO146NDB3
J5	IO129RSB2
J6	IO131RSB2
J7	V _{CC}
J8	TCK
J9	GDA2/IO89RSB2
J10	TDO
J11	GDA1/IO88PDB1
J12	GDB1/IO87PDB1

144-Pin FBGA	
Pin Number	A3P600 Function
K1	GEB0/IO145NDB3
K2	GEA1/IO144PDB3
K3	GEA0/IO144NDB3
K4	GEA2/IO143RSB2
K5	IO119RSB2
K6	IO111RSB2
K7	GND
K8	IO94RSB2
K9	GDC2/IO91RSB2
K10	GND
K11	GDA0/IO88NDB1
K12	GDB0/IO87NDB1
L1	GND
L2	VMV3
L3	GEB2/IO142RSB2
L4	IO136RSB2
L5	V _{CC} B2
L6	IO115RSB2
L7	IO103RSB2
L8	IO97RSB2
L9	TMS
L10	V _{JTAG}
L11	VMV2
L12	TRST
M1	GNDQ
M2	GEC2/IO141RSB2
M3	IO138RSB2
M4	IO123RSB2
M5	IO126RSB2
M6	IO134RSB2
M7	IO108RSB2
M8	IO99RSB2
M9	TDI
M10	V _{CC} B2
M11	V _{PUMP}
M12	GNDQ

144-Pin FBGA	
Pin Number	A3P1000 Function
A1	GNDQ
A2	VMV0
A3	GAB0/IO02RSB0
A4	GAB1/IO03RSB0
A5	IO10RSB0
A6	GND
A7	IO44RSB0
A8	V _{CC}
A9	IO69RSB0
A10	GBA0/IO76RSB0
A11	GBA1/IO77RSB0
A12	GNDQ
B1	GAB2/IO224PDB3
B2	GND
B3	GAA0/IO00RSB0
B4	GAA1/IO01RSB0
B5	IO13RSB0
B6	IO26RSB0
B7	IO35RSB0
B8	IO60RSB0
B9	GBB0/IO74RSB0
B10	GBB1/IO75RSB0
B11	GND
B12	VMV1
C1	IO224NDB3
C2	GFA2/IO206PPB3
C3	GAC2/IO223PDB3
C4	V _{CC}
C5	IO16RSB0
C6	IO29RSB0
C7	IO32RSB0
C8	IO63RSB0
C9	IO66RSB0
C10	GBA2/IO78PDB1
C11	IO78NDB1
C12	GBC2/IO80PPB1

144-Pin FBGA	
Pin Number	A3P1000 Function
D1	IO213PDB3
D2	IO213NDB3
D3	IO223NDB3
D4	GAA2/IO225PPB3
D5	GAC0/IO04RSB0
D6	GAC1/IO05RSB0
D7	GBC0/IO72RSB0
D8	GBC1/IO73RSB0
D9	GBB2/IO79PDB1
D10	IO79NDB1
D11	IO80NPB1
D12	GCB1/IO92PPB1
E1	V _{CC}
E2	GFC0/IO209NDB3
E3	GFC1/IO209PDB3
E4	VCCIB3
E5	IO225NPB3
E6	V _{CC} B0
E7	V _{CC} B0
E8	GCC1/IO91PDB1
E9	V _{CC} B1
E10	V _{CC}
E11	GCA0/IO93NDB1
E12	IO94NDB1
F1	GFB0/IO208NPB3
F2	V _{COMPLF}
F3	GFB1/IO208PPB3
F4	IO206NPB3
F5	GND
F6	GND
F7	GND
F8	GCC0/IO91NDB1
F9	GCB0/IO92NPB1
F10	GND
F11	GCA1/IO93PDB1
F12	GCA2/IO94PDB1

144-Pin FBGA	
Pin Number	A3P1000 Function
G1	GFA1/IO207PPB3
G2	GND
G3	V _{CC} PLF
G4	GFA0/IO207NPB3
G5	GND
G6	GND
G7	GND
G8	GDC1/IO111PPB1
G9	IO96NDB1
G10	GCC2/IO96PDB1
G11	IO95NDB1
G12	GCB2/IO95PDB1
H1	V _{CC}
H2	GFB2/IO205PDB3
H3	GFC2/IO204PSB3
H4	GEC1/IO190PDB3
H5	V _{CC}
H6	IO105PDB1
H7	IO105NDB1
H8	GDB2/IO115RSB2
H9	GDC0/IO111NPB1
H10	V _{CC} B1
H11	IO101PSB1
H12	V _{CC}
J1	GEB1/IO189PDB3
J2	IO205NDB3
J3	V _{CC} B3
J4	GEC0/IO190NDB3
J5	IO160RSB2
J6	IO157RSB2
J7	V _{CC}
J8	TCK
J9	GDA2/IO114RSB2
J10	TDO
J11	GDA1/IO113PDB1
J12	GDB1/IO112PDB1

144-Pin FBGA	
Pin Number	A3P1000 Function
K1	GEB0/IO189NDB3
K2	GEA1/IO188PDB3
K3	GEA0/IO188NDB3
K4	GEA2/IO187RSB2
K5	IO169RSB2
K6	IO152RSB2
K7	GND
K8	IO117RSB2
K9	GDC2/IO116RSB2
K10	GND
K11	GDA0/IO113NDB1
K12	GDB0/IO112NDB1
L1	GND
L2	VMV3
L3	GEB2/IO186RSB2
L4	IO172RSB2
L5	V _{CC} B2
L6	IO153RSB2
L7	IO144RSB2
L8	IO140RSB2
L9	TMS
L10	V _{JTAG}
L11	VMV2
L12	TRST
M1	GNDQ
M2	GEC2/IO185RSB2
M3	IO173RSB2
M4	IO168RSB2
M5	IO161RSB2
M6	IO156RSB2
M7	IO145RSB2
M8	IO141RSB2
M9	TDI
M10	V _{CC} B2
M11	V _{PUMP}
M12	GNDQ

256-Pin FBGA

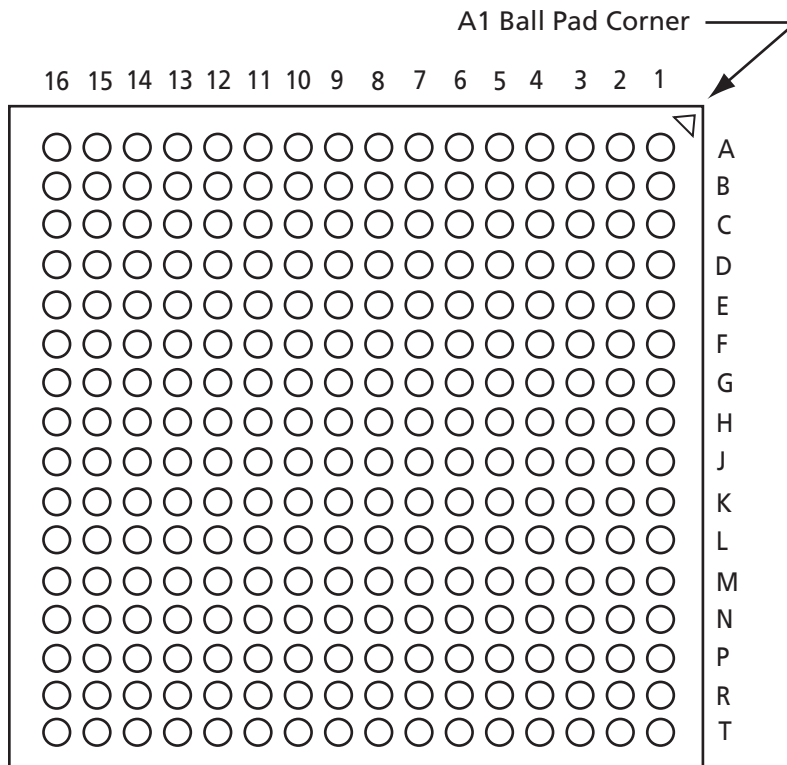

Note: This is the bottom view of the package.

Note

For Package Manufacturing and Environmental information, visit the Resource Center at <http://www.actel.com/products/solutions/package/docs.aspx>.

256-Pin FBGA		256-Pin FBGA		256-Pin FBGA	
Pin Number	A3P250 Function	Pin Number	A3P250 Function	Pin Number	A3P250 Function
A1	GND	C5	GAC0/IO04RSB0	E9	IO24RSB0
A2	GAA0/IO00RSB0	C6	GAC1/IO05RSB0	E10	V _{CC} B0
A3	GAA1/IO01RSB0	C7	IO13RSB0	E11	V _{CC} B0
A4	GAB0/IO02RSB0	C8	IO17RSB0	E12	VMV1
A5	IO07RSB0	C9	IO22RSB0	E13	GBC2/IO43PDB1
A6	IO10RSB0	C10	IO27RSB0	E14	IO46RSB1
A7	IO11RSB0	C11	IO31RSB0	E15	NC
A8	IO15RSB0	C12	GBC0/IO35RSB0	E16	IO45PDB1
A9	IO20RSB0	C13	IO34RSB0	F1	IO113NDB3
A10	IO25RSB0	C14	NC	F2	IO112PPB3
A11	IO29RSB0	C15	IO42NPB1	F3	NC
A12	IO33RSB0	C16	IO44PDB1	F4	IO115VDB3
A13	GBB1/IO38RSB0	D1	IO114VDB3	F5	V _{CC} B3
A14	GBA0/IO39RSB0	D2	IO114UDB3	F6	GND
A15	GBA1/IO40RSB0	D3	GAC2/IO116UDB3	F7	V _{CC}
A16	GND	D4	NC	F8	V _{CC}
B1	GAB2/IO117UDB3	D5	GNDQ	F9	V _{CC}
B2	GAA2/IO118UDB3	D6	IO08RSB0	F10	V _{CC}
B3	NC	D7	IO14RSB0	F11	GND
B4	GAB1/IO03RSB0	D8	IO18RSB0	F12	V _{CC} B1
B5	IO06RSB0	D9	IO23RSB0	F13	IO43NDB1
B6	IO09RSB0	D10	IO28RSB0	F14	NC
B7	IO12RSB0	D11	IO32RSB0	F15	IO47PPB1
B8	IO16RSB0	D12	GNDQ	F16	IO45NDB1
B9	IO21RSB0	D13	NC	G1	IO111NDB3
B10	IO26RSB0	D14	GBB2/IO42PPB1	G2	IO111PDB3
B11	IO30RSB0	D15	NC	G3	IO112NPB3
B12	GBC1/IO36RSB0	D16	IO44NDB1	G4	GFC1/IO110PPB3
B13	GBB0/IO37RSB0	E1	IO113PDB3	G5	V _{CC} B3
B14	NC	E2	NC	G6	V _{CC}
B15	GBA2/IO41PDB1	E3	IO116VDB3	G7	GND
B16	IO41NDB1	E4	IO115UDB3	G8	GND
C1	IO117VDB3	E5	VMV0	G9	GND
C2	IO118VDB3	E6	V _{CC} B0	G10	GND
C3	NC	E7	V _{CC} B0	G11	V _{CC}
C4	NC	E8	IO19RSB0	G12	V _{CC} B1

256-Pin FBGA	
Pin Number	A3P250 Function
G13	GCC1/IO48PPB1
G14	IO47NPB1
G15	IO54PDB1
G16	IO54NDB1
H1	GFB0/IO109NPB3
H2	GFA0/IO108NDB3
H3	GFB1/IO109PPB3
H4	V _{COMPLF}
H5	GFC0/IO110NPB3
H6	V _{CC}
H7	GND
H8	GND
H9	GND
H10	GND
H11	V _{CC}
H12	GCC0/IO48NPB1
H13	GCB1/IO49PPB1
H14	GCA0/IO50NPB1
H15	NC
H16	GCB0/IO49NPB1
J1	GFA2/IO107PPB3
J2	GFA1/IO108PDB3
J3	V _{CCPLF}
J4	IO106NDB3
J5	GFB2/IO106PDB3
J6	V _{CC}
J7	GND
J8	GND
J9	GND
J10	GND
J11	V _{CC}
J12	GCB2/IO52PPB1
J13	GCA1/IO50PPB1
J14	GCC2/IO53PPB1
J15	NC
J16	GCA2/IO51PDB1

256-Pin FBGA	
Pin Number	A3P250 Function
K1	GFC2/IO105PDB3
K2	IO107NPB3
K3	IO104PPB3
K4	NC
K5	V _{CC} B3
K6	V _{CC}
K7	GND
K8	GND
K9	GND
K10	GND
K11	V _{CC}
K12	V _{CC} B1
K13	IO52NPB1
K14	IO55RSB1
K15	IO53NPB1
K16	IO51NDB1
L1	IO105NDB3
L2	IO104NPB3
L3	NC
L4	IO102RSB3
L5	V _{CC} B3
L6	GND
L7	V _{CC}
L8	V _{CC}
L9	V _{CC}
L10	V _{CC}
L11	GND
L12	V _{CC} B1
L13	GDB0/IO59VPB1
L14	IO57VDB1
L15	IO57UDB1
L16	IO56PDB1
M1	IO103PDB3
M2	NC
M3	IO101NPB3
M4	GEC0/IO100NPB3

256-Pin FBGA	
Pin Number	A3P250 Function
M5	VMV3
M6	V _{CC} B2
M7	V _{CC} B2
M8	NC
M9	IO74RSB2
M10	V _{CC} B2
M11	V _{CC} B2
M12	VMV2
M13	NC
M14	GDB1/IO59UPB1
M15	GDC1/IO58UDB1
M16	IO56NDB1
N1	IO103NDB3
N2	IO101PPB3
N3	GEC1/IO100PPB3
N4	NC
N5	GNDQ
N6	GEA2/IO97RSB2
N7	IO86RSB2
N8	IO82RSB2
N9	IO75RSB2
N10	IO69RSB2
N11	IO64RSB2
N12	GNDQ
N13	NC
N14	V _{JTAG}
N15	GDC0/IO58VDB1
N16	GDA1/IO60UDB1
P1	GEB1/IO99PDB3
P2	GEB0/IO99NDB3
P3	NC
P4	NC
P5	IO92RSB2
P6	IO89RSB2
P7	IO85RSB2
P8	IO81RSB2

256-Pin FBGA	
Pin Number	A3P250 Function
P9	IO76RSB2
P10	IO71RSB2
P11	IO66RSB2
P12	NC
P13	TCK
P14	V _{PUMP}
P15	TRST
P16	GDA0/IO60VDB1
R1	GEA1/IO98PDB3
R2	GEA0/IO98NDB3
R3	NC
R4	GEC2/IO95RSB2
R5	IO91RSB2
R6	IO88RSB2
R7	IO84RSB2
R8	IO80RSB2
R9	IO77RSB2
R10	IO72RSB2
R11	IO68RSB2
R12	IO65RSB2
R13	GDB2/IO62RSB2
R14	TDI
R15	NC
R16	TDO
T1	GND
T2	IO94RSB2
T3	GEB2/IO96RSB2
T4	IO93RSB2
T5	IO90RSB2
T6	IO87RSB2
T7	IO83RSB2
T8	IO79RSB2
T9	IO78RSB2
T10	IO73RSB2
T11	IO70RSB2
T12	GDC2/IO63RSB2

256-Pin FBGA	
Pin Number	A3P250 Function
T13	IO67RSB2
T14	GDA2/IO61RSB2
T15	TMS
T16	GND

256-Pin FBGA	
Pin Number	A3P400 Function
A1	GND
A2	GAA0/IO00RSB0
A3	GAA1/IO01RSB0
A4	GAB0/IO02RSB0
A5	IO16RSB0
A6	IO17RSB0
A7	IO22RSB0
A8	IO28RSB0
A9	IO34RSB0
A10	IO37RSB0
A11	IO41RSB0
A12	IO43RSB0
A13	GBB1/IO57RSB0
A14	GBA0/IO58RSB0
A15	GBA1/IO59RSB0
A16	GND
B1	GAB2/IO154UDB3
B2	GAA2/IO155UDB3
B3	IO12RSB0
B4	GAB1/IO03RSB0
B5	IO13RSB0
B6	IO14RSB0
B7	IO21RSB0
B8	IO27RSB0
B9	IO32RSB0
B10	IO38RSB0
B11	IO42RSB0
B12	GBC1/IO55RSB0
B13	GBB0/IO56RSB0
B14	IO44RSB0
B15	GBA2/IO60PDB1
B16	IO60NDB1
C1	IO154VDB3
C2	IO155VDB3
C3	IO11RSB0
C4	IO07RSB0

256-Pin FBGA	
Pin Number	A3P400 Function
C5	GAC0/IO04RSB0
C6	GAC1/IO05RSB0
C7	IO20RSB0
C8	IO24RSB0
C9	IO33RSB0
C10	IO39RSB0
C11	IO45RSB0
C12	GBC0/IO54RSB0
C13	IO48RSB0
C14	VMV0
C15	IO61NPB1
C16	IO63PDB1
D1	IO151VDB3
D2	IO151UDB3
D3	GAC2/IO153UDB3
D4	IO06RSB0
D5	GNDQ
D6	IO10RSB0
D7	IO19RSB0
D8	IO26RSB0
D9	IO30RSB0
D10	IO40RSB0
D11	IO46RSB0
D12	GNDQ
D13	IO47RSB0
D14	GBB2/IO61PPB1
D15	IO53RSB0
D16	IO63NDB1
E1	IO150PDB3
E2	IO08RSB0
E3	IO153VDB3
E4	IO152VDB3
E5	VMV0
E6	V _{CC} B0
E7	V _{CC} B0
E8	IO25RSB0

256-Pin FBGA	
Pin Number	A3P400 Function
E9	IO31RSB0
E10	V _{CC} B0
E11	V _{CC} B0
E12	VMV1
E13	GBC2/IO62PDB1
E14	IO65RSB1
E15	IO52RSB0
E16	IO66PDB1
F1	IO150NDB3
F2	IO149NPB3
F3	IO09RSB0
F4	IO152UDB3
F5	V _{CC} B3
F6	GND
F7	V _{CC}
F8	V _{CC}
F9	V _{CC}
F10	V _{CC}
F11	GND
F12	V _{CC} B1
F13	IO62NDB1
F14	IO49RSB0
F15	IO64PPB1
F16	IO66NDB1
G1	IO148NDB3
G2	IO148PDB3
G3	IO149PPB3
G4	GFC1/IO147PPB3
G5	V _{CC} B3
G6	V _{CC}
G7	GND
G8	GND
G9	GND
G10	GND
G11	V _{CC}
G12	V _{CC} B1

256-Pin FBGA		256-Pin FBGA		256-Pin FBGA	
Pin Number	A3P400 Function	Pin Number	A3P400 Function	Pin Number	A3P400 Function
G13	GCC1/IO67PPB1	K1	GFC2/IO142PDB3	M5	VMV3
G14	IO64NPB1	K2	IO144NPB3	M6	V _{CC} B2
G15	IO73PDB1	K3	IO141PPB3	M7	V _{CC} B2
G16	IO73NDB1	K4	IO120RSB2	M8	IO108RSB2
H1	GFB0/IO146NPB3	K5	V _{CC} B3	M9	IO101RSB2
H2	GFA0/IO145NDB3	K6	V _{CC}	M10	V _{CC} B2
H3	GFB1/IO146PPB3	K7	GND	M11	V _{CC} B2
H4	V _{COMPLF}	K8	GND	M12	VMV2
H5	GFC0/IO147NPB3	K9	GND	M13	IO83RSB2
H6	V _{CC}	K10	GND	M14	GDB1/IO78UPB1
H7	GND	K11	V _{CC}	M15	GDC1/IO77UDB1
H8	GND	K12	V _{CC} B1	M16	IO75NDB1
H9	GND	K13	IO71NPB1	N1	IO140NDB3
H10	GND	K14	IO74RSB1	N2	IO138PPB3
H11	V _{CC}	K15	IO72NPB1	N3	GEC1/IO137PPB3
H12	GCC0/IO67NPB1	K16	IO70NDB1	N4	IO131RSB2
H13	GCB1/IO68PPB1	L1	IO142NDB3	N5	GNDQ
H14	GCA0/IO69NPB1	L2	IO141NPB3	N6	GEA2/IO134RSB2
H15	NC	L3	IO125RSB2	N7	IO117RSB2
H16	GCB0/IO68NPB1	L4	IO139RSB3	N8	IO111RSB2
J1	GFA2/IO144PPB3	L5	V _{CC} B3	N9	IO99RSB2
J2	GFA1/IO145PDB3	L6	GND	N10	IO94RSB2
J3	V _{CC} PLF	L7	V _{CC}	N11	IO87RSB2
J4	IO143NDB3	L8	V _{CC}	N12	GNDQ
J5	GFB2/IO143PDB3	L9	V _{CC}	N13	IO93RSB2
J6	V _{CC}	L10	V _{CC}	N14	V _{JTAG}
J7	GND	L11	GND	N15	GDC0/IO77VDB1
J8	GND	L12	V _{CC} B1	N16	GDA1/IO79UDB1
J9	GND	L13	GDB0/IO78VPB1	P1	GEB1/IO136PDB3
J10	GND	L14	IO76VDB1	P2	GEB0/IO136NDB3
J11	V _{CC}	L15	IO76UDB1	P3	VMV2
J12	GCB2/IO71PPB1	L16	IO75PDB1	P4	IO129RSB2
J13	GCA1/IO69PPB1	M1	IO140PDB3	P5	IO128RSB2
J14	GCC2/IO72PPB1	M2	IO130RSB2	P6	IO122RSB2
J15	NC	M3	IO138NPB3	P7	IO115RSB2
J16	GCA2/IO70PDB1	M4	GEC0/IO137NPB3	P8	IO110RSB2

256-Pin FBGA	
Pin Number	A3P400 Function
P9	IO98RSB2
P10	IO95RSB2
P11	IO88RSB2
P12	IO84RSB2
P13	TCK
P14	V _{PUMP}
P15	TRST
P16	GDA0/IO79VDB1
R1	GEA1/IO135PDB3
R2	GEA0/IO135NDB3
R3	IO127RSB2
R4	GEC2/IO132RSB2
R5	IO123RSB2
R6	IO118RSB2
R7	IO112RSB2
R8	IO106RSB2
R9	IO100RSB2
R10	IO96RSB2
R11	IO89RSB2
R12	IO85RSB2
R13	GDB2/IO81RSB2
R14	TDI
R15	NC
R16	TDO
T1	GND
T2	IO126RSB2
T3	GEB2/IO133RSB2
T4	IO124RSB2
T5	IO116RSB2
T6	IO113RSB2
T7	IO107RSB2
T8	IO105RSB2
T9	IO102RSB2
T10	IO97RSB2
T11	IO92RSB2
T12	GDC2/IO82RSB2

256-Pin FBGA	
Pin Number	A3P400 Function
T13	IO86RSB2
T14	GDA2/IO80RSB2
T15	TMS
T16	GND

256-Pin FBGA		256-Pin FBGA		256-Pin FBGA	
Pin Number	A3P600 Function	Pin Number	A3P600 Function	Pin Number	A3P600 Function
A1	GND	C5	GAC0/IO04RSB0	E9	IO31RSB0
A2	GAA0/IO00RSB0	C6	GAC1/IO05RSB0	E10	V _{CC} B0
A3	GAA1/IO01RSB0	C7	IO20RSB0	E11	V _{CC} B0
A4	GAB0/IO02RSB0	C8	IO24RSB0	E12	VMV1
A5	IO11RSB0	C9	IO33RSB0	E13	GBC2/IO62PDB1
A6	IO16RSB0	C10	IO39RSB0	E14	IO67PPB1
A7	IO18RSB0	C11	IO44RSB0	E15	IO64PPB1
A8	IO28RSB0	C12	GBC0/IO54RSB0	E16	IO66PDB1
A9	IO34RSB0	C13	IO51RSB0	F1	IO166NDB3
A10	IO37RSB0	C14	VMV0	F2	IO168NPB3
A11	IO41RSB0	C15	IO61NPB1	F3	IO167PPB3
A12	IO43RSB0	C16	IO63PDB1	F4	IO169PDB3
A13	GBB1/IO57RSB0	D1	IO171NDB3	F5	V _{CC} B3
A14	GBA0/IO58RSB0	D2	IO171PDB3	F6	GND
A15	GBA1/IO59RSB0	D3	GAC2/IO172PDB3	F7	V _{CC}
A16	GND	D4	IO06RSB0	F8	V _{CC}
B1	GAB2/IO173PDB3	D5	GNDQ	F9	V _{CC}
B2	GAA2/IO174PDB3	D6	IO10RSB0	F10	V _{CC}
B3	GNDQ	D7	IO19RSB0	F11	GND
B4	GAB1/IO03RSB0	D8	IO26RSB0	F12	V _{CC} B1
B5	IO13RSB0	D9	IO30RSB0	F13	IO62NDB1
B6	IO14RSB0	D10	IO40RSB0	F14	IO64NPB1
B7	IO21RSB0	D11	IO45RSB0	F15	IO65PPB1
B8	IO27RSB0	D12	GNDQ	F16	IO66NDB1
B9	IO32RSB0	D13	IO50RSB0	G1	IO165NDB3
B10	IO38RSB0	D14	GBB2/IO61PPB1	G2	IO165PDB3
B11	IO42RSB0	D15	IO53RSB0	G3	IO168PPB3
B12	GBC1/IO55RSB0	D16	IO63NDB1	G4	GFC1/IO164PPB3
B13	GBB0/IO56RSB0	E1	IO166PDB3	G5	V _{CC} B3
B14	IO52RSB0	E2	IO167NPB3	G6	V _{CC}
B15	GBA2/IO60PDB1	E3	IO172NDB3	G7	GND
B16	IO60NDB1	E4	IO169NDB3	G8	GND
C1	IO173NDB3	E5	VMV0	G9	GND
C2	IO174NDB3	E6	V _{CC} B0	G10	GND
C3	VMV3	E7	V _{CC} B0	G11	V _{CC}
C4	IO07RSB0	E8	IO25RSB0	G12	V _{CC} B1

256-Pin FBGA	
Pin Number	A3P600 Function
G13	GCC1/IO69PPB1
G14	IO65NPB1
G15	IO75PDB1
G16	IO75NDB1
H1	GFB0/IO163NPB3
H2	GFA0/IO162NDB3
H3	GFB1/IO163PPB3
H4	V _{COMPLF}
H5	GFC0/IO164NPB3
H6	V _{CC}
H7	GND
H8	GND
H9	GND
H10	GND
H11	V _{CC}
H12	GCC0/IO69NPB1
H13	GCB1/IO70PPB1
H14	GCA0/IO71NPB1
H15	IO67NPB1
H16	GCB0/IO70NPB1
J1	GFA2/IO161PPB3
J2	GFA1/IO162PDB3
J3	V _{CCPLF}
J4	IO160NDB3
J5	GFB2/IO160PDB3
J6	V _{CC}
J7	GND
J8	GND
J9	GND
J10	GND
J11	V _{CC}
J12	GCB2/IO73PPB1
J13	GCA1/IO71PPB1
J14	GCC2/IO74PPB1
J15	IO80PPB1
J16	GCA2/IO72PDB1

256-Pin FBGA	
Pin Number	A3P600 Function
K1	GFC2/IO159PDB3
K2	IO161NPB3
K3	IO156PPB3
K4	IO129RSB2
K5	V _{CC} B3
K6	V _{CC}
K7	GND
K8	GND
K9	GND
K10	GND
K11	V _{CC}
K12	V _{CC} B1
K13	IO73NPB1
K14	IO80NPB1
K15	IO74NPB1
K16	IO72NDB1
L1	IO159NDB3
L2	IO156NPB3
L3	IO151PPB3
L4	IO158PSB3
L5	V _{CC} B3
L6	GND
L7	V _{CC}
L8	V _{CC}
L9	V _{CC}
L10	V _{CC}
L11	GND
L12	V _{CC} B1
L13	GDB0/IO87NPB1
L14	IO85NDB1
L15	IO85PDB1
L16	IO84PDB1
M1	IO150PDB3
M2	IO151NPB3
M3	IO147NPB3
M4	GEC0/IO146NPB3

256-Pin FBGA	
Pin Number	A3P600 Function
M5	VMV3
M6	V _{CC} B2
M7	V _{CC} B2
M8	IO117RSB2
M9	IO110RSB2
M10	V _{CC} B2
M11	V _{CC} B2
M12	VMV2
M13	IO94RSB2
M14	GDB1/IO87PPB1
M15	GDC1/IO86PDB1
M16	IO84NDB1
N1	IO150NDB3
N2	IO147PPB3
N3	GEC1/IO146PPB3
N4	IO140RSB2
N5	GNDQ
N6	GEA2/IO143RSB2
N7	IO126RSB2
N8	IO120RSB2
N9	IO108RSB2
N10	IO103RSB2
N11	IO99RSB2
N12	GNDQ
N13	IO92RSB2
N14	V _{JTAG}
N15	GDC0/IO86NDB1
N16	GDA1/IO88PDB1
P1	GEB1/IO145PDB3
P2	GEB0/IO145NDB3
P3	VMV2
P4	IO138RSB2
P5	IO136RSB2
P6	IO131RSB2
P7	IO124RSB2
P8	IO119RSB2

256-Pin FBGA	
Pin Number	A3P600 Function
P9	IO107RSB2
P10	IO104RSB2
P11	IO97RSB2
P12	VMV1
P13	TCK
P14	V _{PUMP}
P15	TRST
P16	GDA0/IO88NDB1
R1	GEA1/IO144PDB3
R2	GEA0/IO144NDB3
R3	IO139RSB2
R4	GEC2/IO141RSB2
R5	IO132RSB2
R6	IO127RSB2
R7	IO121RSB2
R8	IO114RSB2
R9	IO109RSB2
R10	IO105RSB2
R11	IO98RSB2
R12	IO96RSB2
R13	GDB2/IO90RSB2
R14	TDI
R15	GNDQ
R16	TDO
T1	GND
T2	IO137RSB2
T3	GEB2/IO142RSB2
T4	IO134RSB2
T5	IO125RSB2
T6	IO123RSB2
T7	IO118RSB2
T8	IO115RSB2
T9	IO111RSB2
T10	IO106RSB2
T11	IO102RSB2
T12	GDC2/IO91RSB2

256-Pin FBGA	
Pin Number	A3P600 Function
T13	IO93RSB2
T14	GDA2/IO89RSB2
T15	TMS
T16	GND

256-Pin FBGA	
Pin Number	A3P1000 Function
A1	GND
A2	GAA0/IO00RSB0
A3	GAA1/IO01RSB0
A4	GAB0/IO02RSB0
A5	IO16RSB0
A6	IO22RSB0
A7	IO28RSB0
A8	IO35RSB0
A9	IO45RSB0
A10	IO50RSB0
A11	IO55RSB0
A12	IO61RSB0
A13	GBB1/IO75RSB0
A14	GBA0/IO76RSB0
A15	GBA1/IO77RSB0
A16	GND
B1	GAB2/IO224PDB3
B2	GAA2/IO225PDB3
B3	GNDQ
B4	GAB1/IO03RSB0
B5	IO17RSB0
B6	IO21RSB0
B7	IO27RSB0
B8	IO34RSB0
B9	IO44RSB0
B10	IO51RSB0
B11	IO57RSB0
B12	GBC1/IO73RSB0
B13	GBB0/IO74RSB0
B14	IO71RSB0
B15	GBA2/IO78PDB1
B16	IO81PDB1
C1	IO224NDB3
C2	IO225NDB3
C3	VMV3
C4	IO11RSB0
C5	GAC0/IO04RSB0
C6	GAC1/IO05RSB0

256-Pin FBGA	
Pin Number	A3P1000 Function
C7	IO25RSB0
C8	IO36RSB0
C9	IO42RSB0
C10	IO49RSB0
C11	IO56RSB0
C12	GBC0/IO72RSB0
C13	IO62RSB0
C14	VMV0
C15	IO78NDB1
C16	IO81NDB1
D1	IO222NDB3
D2	IO222PDB3
D3	GAC2/IO223PDB3
D4	IO223NDB3
D5	GNDQ
D6	IO23RSB0
D7	IO29RSB0
D8	IO33RSB0
D9	IO46RSB0
D10	IO52RSB0
D11	IO60RSB0
D12	GNDQ
D13	IO80NDB1
D14	GBB2/IO79PDB1
D15	IO79NDB1
D16	IO82NSB1
E1	IO217PDB3
E2	IO218PDB3
E3	IO221NDB3
E4	IO221PDB3
E5	VMV0
E6	V _{CC} B0
E7	V _{CC} B0
E8	IO38RSB0
E9	IO47RSB0
E10	V _{CC} B0
E11	V _{CC} B0
E12	VMV1

256-Pin FBGA	
Pin Number	A3P1000 Function
E13	GBC2/IO80PDB1
E14	IO83PPB1
E15	IO86PPB1
E16	IO87PDB1
F1	IO217NDB3
F2	IO218NDB3
F3	IO216PDB3
F4	IO216NDB3
F5	V _{CC} B3
F6	GND
F7	V _{CC}
F8	V _{CC}
F9	V _{CC}
F10	V _{CC}
F11	GND
F12	V _{CC} B1
F13	IO83NPB1
F14	IO86NPB1
F15	IO90PPB1
F16	IO87NDB1
G1	IO210PSB3
G2	IO213NDB3
G3	IO213PDB3
G4	GFC1/IO209PPB3
G5	V _{CC} B3
G6	V _{CC}
G7	GND
G8	GND
G9	GND
G10	GND
G11	V _{CC}
G12	V _{CC} B1
G13	GCC1/IO91PPB1
G14	IO90NPB1
G15	IO88PDB1
G16	IO88NDB1
H1	GFB0/IO208NPB3
H2	GFA0/IO207NDB3

256-Pin FBGA		256-Pin FBGA		256-Pin FBGA	
Pin Number	A3P1000 Function	Pin Number	A3P1000 Function	Pin Number	A3P1000 Function
H3	GFB1/IO208PPB3	K9	GND	M15	GDC1/IO111PDB1
H4	V _{COMPLF}	K10	GND	M16	IO107NDB1
H5	GFC0/IO209NPB3	K11	V _{CC}	N1	IO194PSB3
H6	V _{CC}	K12	V _{CC} B1	N2	IO192PPB3
H7	GND	K13	IO95NPB1	N3	GEC1/IO190PPB3
H8	GND	K14	IO100NPB1	N4	IO192NPB3
H9	GND	K15	IO102NDB1	N5	GNDQ
H10	GND	K16	IO102PDB1	N6	GEA2/IO187RSB2
H11	V _{CC}	L1	IO202NDB3	N7	IO161RSB2
H12	GCC0/IO91NPB1	L2	IO202PDB3	N8	IO155RSB2
H13	GCB1/IO92PPB1	L3	IO196PPB3	N9	IO141RSB2
H14	GCA0/IO93NPB1	L4	IO193PPB3	N10	IO129RSB2
H15	IO96NPB1	L5	V _{CC} B3	N11	IO124RSB2
H16	GCB0/IO92NPB1	L6	GND	N12	GNDQ
J1	GFA2/IO206PSB3	L7	V _{CC}	N13	IO110PDB1
J2	GFA1/IO207PDB3	L8	V _{CC}	N14	V _{JTAG}
J3	V _{CC} PLF	L9	V _{CC}	N15	GDC0/IO111NDB1
J4	IO205NDB3	L10	V _{CC}	N16	GDA1/IO113PDB1
J5	GFB2/IO205PDB3	L11	GND	P1	GEB1/IO189PDB3
J6	V _{CC}	L12	V _{CC} B1	P2	GEB0/IO189NDB3
J7	GND	L13	GDB0/IO112NPB1	P3	VMV2
J8	GND	L14	IO106NDB1	P4	IO179RSB2
J9	GND	L15	IO106PDB1	P5	IO171RSB2
J10	GND	L16	IO107PDB1	P6	IO165RSB2
J11	V _{CC}	M1	IO197NSB3	P7	IO159RSB2
J12	GCB2/IO95PPB1	M2	IO196NPB3	P8	IO151RSB2
J13	GCA1/IO93PPB1	M3	IO193NPB3	P9	IO137RSB2
J14	GCC2/IO96PPB1	M4	GEC0/IO190NPB3	P10	IO134RSB2
J15	IO100PPB1	M5	VMV3	P11	IO128RSB2
J16	GCA2/IO94PSB1	M6	V _{CC} B2	P12	VMV1
K1	GFC2/IO204PDB3	M7	V _{CC} B2	P13	TCK
K2	IO204NDB3	M8	IO147RSB2	P14	V _{PUMP}
K3	IO203NDB3	M9	IO136RSB2	P15	TRST
K4	IO203PDB3	M10	V _{CC} B2	P16	GDA0/IO113NDB1
K5	V _{CC} B3	M11	V _{CC} B2	R1	GEA1/IO188PDB3
K6	V _{CC}	M12	VMV2	R2	GEA0/IO188NDB3
K7	GND	M13	IO110NDB1	R3	IO184RSB2
K8	GND	M14	GDB1/IO112PPB1	R4	GEC2/IO185RSB2

256-Pin FBGA	
Pin Number	A3P1000 Function
R5	IO168RSB2
R6	IO163RSB2
R7	IO157RSB2
R8	IO149RSB2
R9	IO143RSB2
R10	IO138RSB2
R11	IO131RSB2
R12	IO125RSB2
R13	GDB2/IO115RSB2
R14	TDI
R15	GNDQ
R16	TDO
T1	GND
T2	IO183RSB2
T3	GEB2/IO186RSB2
T4	IO172RSB2
T5	IO170RSB2
T6	IO164RSB2
T7	IO158RSB2
T8	IO153RSB2
T9	IO142RSB2
T10	IO135RSB2
T11	IO130RSB2
T12	GDC2/IO116RSB2
T13	IO120RSB2
T14	GDA2/IO114RSB2
T15	TMS
T16	GND

484-Pin FBGA

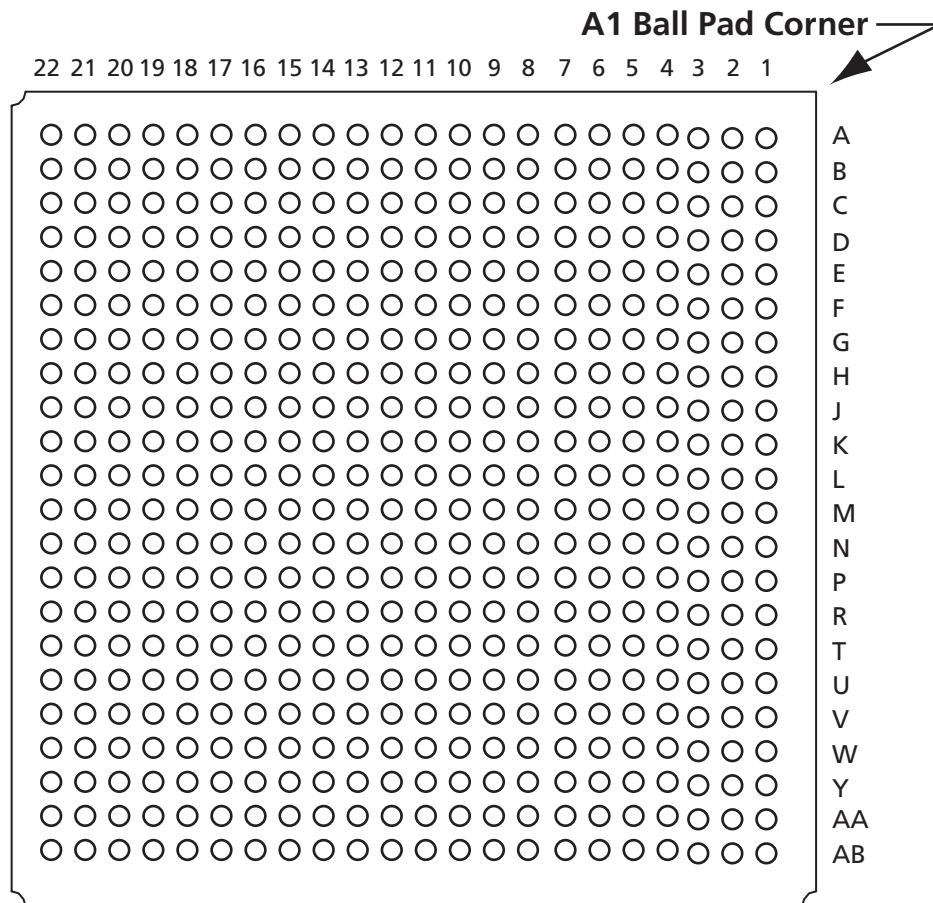

Note: This is the bottom view of the package.

Note

For Package Manufacturing and Environmental information, visit the Resource Center at <http://www.actel.com/products/solutions/package/docs.aspx>.

484-Pin FBGA	
Pin Number	A3P400 Function
A1	GND
A2	GND
A3	V _{CC} B0
A4	NC
A5	NC
A6	IO15RSB0
A7	IO18RSB0
A8	NC
A9	NC
A10	IO23RSB0
A11	IO29RSB0
A12	IO35RSB0
A13	IO36RSB0
A14	NC
A15	NC
A16	IO50RSB0
A17	IO51RSB0
A18	NC
A19	NC
A20	V _{CC} B0
A21	GND
A22	GND
B1	GND
B2	V _{CC} B3
B3	NC
B4	NC
B5	NC
B6	NC
B7	NC
B8	NC
B9	NC
B10	NC
B11	NC
B12	NC
B13	NC
B14	NC

484-Pin FBGA	
Pin Number	A3P400 Function
B15	NC
B16	NC
B17	NC
B18	NC
B19	NC
B20	NC
B21	V _{CC} B1
B22	GND
C1	V _{CC} B3
C2	NC
C3	NC
C4	NC
C5	GND
C6	NC
C7	NC
C8	V _{CC}
C9	V _{CC}
C10	NC
C11	NC
C12	NC
C13	NC
C14	V _{CC}
C15	V _{CC}
C16	NC
C17	NC
C18	GND
C19	NC
C20	NC
C21	NC
C22	V _{CC} B1
D1	NC
D2	NC
D3	NC
D4	GND
D5	GAA0/IO00RSB0
D6	GAA1/IO01RSB0

484-Pin FBGA	
Pin Number	A3P400 Function
D7	GAB0/IO02RSB0
D8	IO16RSB0
D9	IO17RSB0
D10	IO22RSB0
D11	IO28RSB0
D12	IO34RSB0
D13	IO37RSB0
D14	IO41RSB0
D15	IO43RSB0
D16	GBB1/IO57RSB0
D17	GBA0/IO58RSB0
D18	GBA1/IO59RSB0
D19	GND
D20	NC
D21	NC
D22	NC
E1	NC
E2	NC
E3	GND
E4	GAB2/IO154UDB3
E5	GAA2/IO155UDB3
E6	IO12RSB0
E7	GAB1/IO03RSB0
E8	IO13RSB0
E9	IO14RSB0
E10	IO21RSB0
E11	IO27RSB0
E12	IO32RSB0
E13	IO38RSB0
E14	IO42RSB0
E15	GBC1/IO55RSB0
E16	GBB0/IO56RSB0
E17	IO44RSB0
E18	GBA2/IO60PDB1
E19	IO60NDB1
E20	GND

484-Pin FBGA		484-Pin FBGA		484-Pin FBGA	
Pin Number	A3P400 Function	Pin Number	A3P400 Function	Pin Number	A3P400 Function
E21	NC	G13	IO40RSB0	J5	IO149NPB3
E22	NC	G14	IO46RSB0	J6	IO09RSB0
F1	NC	G15	GNDQ	J7	IO152UDB3
F2	NC	G16	IO47RSB0	J8	V _{CC} B3
F3	NC	G17	GBB2/IO61PPB1	J9	GND
F4	IO154VDB3	G18	IO53RSB0	J10	V _{CC}
F5	IO155VDB3	G19	IO63NDB1	J11	V _{CC}
F6	IO11RSB0	G20	NC	J12	V _{CC}
F7	IO07RSB0	G21	NC	J13	V _{CC}
F8	GAC0/IO04RSB0	G22	NC	J14	GND
F9	GAC1/IO05RSB0	H1	NC	J15	V _{CC} B1
F10	IO20RSB0	H2	NC	J16	IO62NDB1
F11	IO24RSB0	H3	V _{CC}	J17	IO49RSB0
F12	IO33RSB0	H4	IO150PDB3	J18	IO64PPB1
F13	IO39RSB0	H5	IO08RSB0	J19	IO66NDB1
F14	IO45RSB0	H6	IO153VDB3	J20	NC
F15	GBC0/IO54RSB0	H7	IO152VDB3	J21	NC
F16	IO48RSB0	H8	VMV0	J22	NC
F17	VMV0	H9	V _{CC} B0	K1	NC
F18	IO61NPB1	H10	V _{CC} B0	K2	NC
F19	IO63PDB1	H11	IO25RSB0	K3	NC
F20	NC	H12	IO31RSB0	K4	IO148NDB3
F21	NC	H13	V _{CC} B0	K5	IO148PDB3
F22	NC	H14	V _{CC} B0	K6	IO149PPB3
G1	NC	H15	VMV1	K7	GFC1/IO147PPB3
G2	NC	H16	GBC2/IO62PDB1	K8	V _{CC} B3
G3	NC	H17	IO65RSB1	K9	V _{CC}
G4	IO151VDB3	H18	IO52RSB0	K10	GND
G5	IO151UDB3	H19	IO66PDB1	K11	GND
G6	GAC2/IO153UDB3	H20	V _{CC}	K12	GND
G7	IO06RSB0	H21	NC	K13	GND
G8	GNDQ	H22	NC	K14	V _{CC}
G9	IO10RSB0	J1	NC	K15	V _{CC} B1
G10	IO19RSB0	J2	NC	K16	GCC1/IO67PPB1
G11	IO26RSB0	J3	NC	K17	IO64NPB1
G12	IO30RSB0	J4	IO150NDB3	K18	IO73PDB1

484-Pin FBGA	
Pin Number	A3P400 Function
K19	IO73NDB1
K20	NC
K21	NC
K22	NC
L1	NC
L2	NC
L3	NC
L4	GFB0/IO146NPB3
L5	GFA0/IO145NDB3
L6	GFB1/IO146PPB3
L7	V _{COMPLF}
L8	GFC0/IO147NPB3
L9	V _{CC}
L10	GND
L11	GND
L12	GND
L13	GND
L14	V _{CC}
L15	GCC0/IO67NPB1
L16	GCB1/IO68PPB1
L17	GCA0/IO69NPB1
L18	NC
L19	GCB0/IO68NPB1
L20	NC
L21	NC
L22	NC
M1	NC
M2	NC
M3	NC
M4	GFA2/IO144PPB3
M5	GFA1/IO145PDB3
M6	V _{CCPLF}
M7	IO143NDB3
M8	GFB2/IO143PDB3
M9	V _{CC}
M10	GND

484-Pin FBGA	
Pin Number	A3P400 Function
M11	GND
M12	GND
M13	GND
M14	V _{CC}
M15	GCB2/IO71PPB1
M16	GCA1/IO69PPB1
M17	GCC2/IO72PPB1
M18	NC
M19	GCA2/IO70PDB1
M20	NC
M21	NC
M22	NC
N1	NC
N2	NC
N3	NC
N4	GFC2/IO142PDB3
N5	IO144NPB3
N6	IO141PPB3
N7	IO120RSB2
N8	V _{CC} B3
N9	V _{CC}
N10	GND
N11	GND
N12	GND
N13	GND
N14	V _{CC}
N15	V _{CC} B1
N16	IO71NPB1
N17	IO74RSB1
N18	IO72NPB1
N19	IO70NDB1
N20	NC
N21	NC
N22	NC
P1	NC
P2	NC

484-Pin FBGA	
Pin Number	A3P400 Function
P3	NC
P4	IO142NDB3
P5	IO141NPB3
P6	IO125RSB2
P7	IO139RSB3
P8	V _{CC} B3
P9	GND
P10	V _{CC}
P11	V _{CC}
P12	V _{CC}
P13	V _{CC}
P14	GND
P15	V _{CC} B1
P16	GDB0/IO78VPB1
P17	IO76VDB1
P18	IO76UDB1
P19	IO75PDB1
P20	NC
P21	NC
P22	NC
R1	NC
R2	NC
R3	V _{CC}
R4	IO140PDB3
R5	IO130RSB2
R6	IO138NPB3
R7	GEC0/IO137NPB3
R8	VMV3
R9	V _{CC} B2
R10	V _{CC} B2
R11	IO108RSB2
R12	IO101RSB2
R13	V _{CC} B2
R14	V _{CC} B2
R15	VMV2
R16	IO83RSB2

484-Pin FBGA		484-Pin FBGA		484-Pin FBGA	
Pin Number	A3P400 Function	Pin Number	A3P400 Function	Pin Number	A3P400 Function
R17	GDB1/IO78UPB1	U9	IO122RSB2	W1	NC
R18	GDC1/IO77UDB1	U10	IO115RSB2	W2	NC
R19	IO75NDB1	U11	IO110RSB2	W3	NC
R20	V _{CC}	U12	IO98RSB2	W4	GND
R21	NC	U13	IO95RSB2	W5	IO126RSB2
R22	NC	U14	IO88RSB2	W6	GEB2/IO133RSB2
T1	NC	U15	IO84RSB2	W7	IO124RSB2
T2	NC	U16	TCK	W8	IO116RSB2
T3	NC	U17	V _{PUMP}	W9	IO113RSB2
T4	IO140NDB3	U18	TRST	W10	IO107RSB2
T5	IO138PPB3	U19	GDA0/IO79VDB1	W11	IO105RSB2
T6	GEC1/IO137PPB3	U20	NC	W12	IO102RSB2
T7	IO131RSB2	U21	NC	W13	IO97RSB2
T8	GNDQ	U22	NC	W14	IO92RSB2
T9	GEA2/IO134RSB2	V1	NC	W15	GDC2/IO82RSB2
T10	IO117RSB2	V2	NC	W16	IO86RSB2
T11	IO111RSB2	V3	GND	W17	GDA2/IO80RSB2
T12	IO99RSB2	V4	GEA1/IO135PDB3	W18	TMS
T13	IO94RSB2	V5	GEA0/IO135NDB3	W19	GND
T14	IO87RSB2	V6	IO127RSB2	W20	NC
T15	GNDQ	V7	GEC2/IO132RSB2	W21	NC
T16	IO93RSB2	V8	IO123RSB2	W22	NC
T17	V _{JTAG}	V9	IO118RSB2	Y1	V _{CC} B3
T18	GDC0/IO77VDB1	V10	IO112RSB2	Y2	NC
T19	GDA1/IO79UDB1	V11	IO106RSB2	Y3	NC
T20	NC	V12	IO100RSB2	Y4	NC
T21	NC	V13	IO96RSB2	Y5	GND
T22	NC	V14	IO89RSB2	Y6	NC
U1	NC	V15	IO85RSB2	Y7	NC
U2	NC	V16	GDB2/IO81RSB2	Y8	V _{CC}
U3	NC	V17	TDI	Y9	V _{CC}
U4	GEB1/IO136PDB3	V18	NC	Y10	NC
U5	GEB0/IO136NDB3	V19	TDO	Y11	NC
U6	VMV2	V20	GND	Y12	NC
U7	IO129RSB2	V21	NC	Y13	NC
U8	IO128RSB2	V22	NC	Y14	V _{CC}

484-Pin FBGA	
Pin Number	A3P400 Function
Y15	V _{CC}
Y16	NC
Y17	NC
Y18	GND
Y19	NC
Y20	NC
Y21	NC
Y22	V _{CC} B1
AA1	GND
AA2	V _{CC} B3
AA3	NC
AA4	NC
AA5	NC
AA6	NC
AA7	NC
AA8	NC
AA9	NC
AA10	NC
AA11	NC
AA12	NC
AA13	NC
AA14	NC
AA15	NC
AA16	NC
AA17	NC
AA18	NC
AA19	NC
AA20	NC
AA21	V _{CC} B1
AA22	GND
AB1	GND
AB2	GND
AB3	V _{CC} B2
AB4	NC
AB5	NC
AB6	IO121RSB2

484-Pin FBGA	
Pin Number	A3P400 Function
AB7	IO119RSB2
AB8	IO114RSB2
AB9	IO109RSB2
AB10	NC
AB11	NC
AB12	IO104RSB2
AB13	IO103RSB2
AB14	NC
AB15	NC
AB16	IO91RSB2
AB17	IO90RSB2
AB18	NC
AB19	NC
AB20	V _{CC} B2
AB21	GND
AB22	GND

484-Pin FBGA		484-Pin FBGA		484-Pin FBGA	
Pin Number	A3P600 Function	Pin Number	A3P600 Function	Pin Number	A3P600 Function
A1	GND	B15	NC	D7	GAB0/IO02RSB0
A2	GND	B16	IO47RSB0	D8	IO11RSB0
A3	VCCIB0	B17	IO49RSB0	D9	IO16RSB0
A4	NC	B18	NC	D10	IO18RSB0
A5	NC	B19	NC	D11	IO28RSB0
A6	IO09RSB0	B20	NC	D12	IO34RSB0
A7	IO15RSB0	B21	V _{CCI} B1	D13	IO37RSB0
A8	NC	B22	GND	D14	IO41RSB0
A9	NC	C1	V _{CCI} B3	D15	IO43RSB0
A10	IO22RSB0	C2	NC	D16	GBB1/IO57RSB0
A11	IO23RSB0	C3	NC	D17	GBA0/IO58RSB0
A12	IO29RSB0	C4	NC	D18	GBA1/IO59RSB0
A13	IO35RSB0	C5	GND	D19	GND
A14	NC	C6	NC	D20	NC
A15	NC	C7	NC	D21	NC
A16	IO46RSB0	C8	V _{CC}	D22	NC
A17	IO48RSB0	C9	V _{CC}	E1	NC
A18	NC	C10	NC	E2	NC
A19	NC	C11	NC	E3	GND
A20	V _{CCI} B0	C12	NC	E4	GAB2/IO173PDB3
A21	GND	C13	NC	E5	GAA2/IO174PDB3
A22	GND	C14	V _{CC}	E6	GNDQ
B1	GND	C15	V _{CC}	E7	GAB1/IO03RSB0
B2	V _{CCI} B3	C16	NC	E8	IO13RSB0
B3	NC	C17	NC	E9	IO14RSB0
B4	NC	C18	GND	E10	IO21RSB0
B5	NC	C19	NC	E11	IO27RSB0
B6	IO08RSB0	C20	NC	E12	IO32RSB0
B7	IO12RSB0	C21	NC	E13	IO38RSB0
B8	NC	C22	V _{CCI} B1	E14	IO42RSB0
B9	NC	D1	NC	E15	GBC1/IO55RSB0
B10	IO17RSB0	D2	NC	E16	GBB0/IO56RSB0
B11	NC	D3	NC	E17	IO52RSB0
B12	NC	D4	GND	E18	GBA2/IO60PDB1
B13	IO36RSB0	D5	GAA0/IO00RSB0	E19	IO60NDB1
B14	NC	D6	GAA1/IO01RSB0	E20	GND

484-Pin FBGA	
Pin Number	A3P600 Function
E21	NC
E22	NC
F1	NC
F2	NC
F3	NC
F4	IO173NDB3
F5	IO174NDB3
F6	VMV3
F7	IO07RSB0
F8	GAC0/IO04RSB0
F9	GAC1/IO05RSB0
F10	IO20RSB0
F11	IO24RSB0
F12	IO33RSB0
F13	IO39RSB0
F14	IO44RSB0
F15	GBC0/IO54RSB0
F16	IO51RSB0
F17	VMV0
F18	IO61NPB1
F19	IO63PDB1
F20	NC
F21	NC
F22	NC
G1	IO170NDB3
G2	IO170PDB3
G3	NC
G4	IO171NDB3
G5	IO171PDB3
G6	GAC2/IO172PDB3
G7	IO06RSB0
G8	GNDQ
G9	IO10RSB0
G10	IO19RSB0
G11	IO26RSB0
G12	IO30RSB0

484-Pin FBGA	
Pin Number	A3P600 Function
G13	IO40RSB0
G14	IO45RSB0
G15	GNDQ
G16	IO50RSB0
G17	GBB2/IO61PPB1
G18	IO53RSB0
G19	IO63NDB1
G20	NC
G21	NC
G22	NC
H1	NC
H2	NC
H3	V _{CC}
H4	IO166PDB3
H5	IO167NPB3
H6	IO172NDB3
H7	IO169NDB3
H8	VMV0
H9	V _{CC} B0
H10	V _{CC} B0
H11	IO25RSB0
H12	IO31RSB0
H13	V _{CC} B0
H14	V _{CC} B0
H15	VMV1
H16	GBC2/IO62PDB1
H17	IO67PPB1
H18	IO64PPB1
H19	IO66PDB1
H20	V _{CC}
H21	NC
H22	NC
J1	NC
J2	NC
J3	NC
J4	IO166NDB3

484-Pin FBGA	
Pin Number	A3P600 Function
J5	IO168NPB3
J6	IO167PPB3
J7	IO169PDB3
J8	V _{CC} B3
J9	GND
J10	V _{CC}
J11	V _{CC}
J12	V _{CC}
J13	V _{CC}
J14	GND
J15	V _{CC} B1
J16	IO62NDB1
J17	IO64NPB1
J18	IO65PPB1
J19	IO66NDB1
J20	NC
J21	IO68PDB1
J22	IO68NDB1
K1	IO157PDB3
K2	IO157NDB3
K3	NC
K4	IO165NDB3
K5	IO165PDB3
K6	IO168PPB3
K7	GFC1/IO164PPB3
K8	V _{CC} B3
K9	V _{CC}
K10	GND
K11	GND
K12	GND
K13	GND
K14	V _{CC}
K15	V _{CC} B1
K16	GCC1/IO69PPB1
K17	IO65NPB1
K18	IO75PDB1

484-Pin FBGA		484-Pin FBGA		484-Pin FBGA	
Pin Number	A3P600 Function	Pin Number	A3P600 Function	Pin Number	A3P600 Function
K19	IO75NDB1	M11	GND	P3	IO153NDB3
K20	NC	M12	GND	P4	IO159NDB3
K21	IO76NDB1	M13	GND	P5	IO156NPB3
K22	IO76PDB1	M14	V _{CC}	P6	IO151PPB3
L1	NC	M15	GCB2/IO73PPB1	P7	IO158PPB3
L2	IO155PDB3	M16	GCA1/IO71PPB1	P8	V _{CC} B3
L3	NC	M17	GCC2/IO74PPB1	P9	GND
L4	GFB0/IO163NPB3	M18	IO80PPB1	P10	V _{CC}
L5	GFA0/IO162NDB3	M19	GCA2/IO72PDB1	P11	V _{CC}
L6	GFB1/IO163PPB3	M20	IO79PPB1	P12	V _{CC}
L7	V _{CC} PLF	M21	IO78PPB1	P13	V _{CC}
L8	GFC0/IO164NPB3	M22	NC	P14	GND
L9	V _{CC}	N1	IO154NDB3	P15	V _{CC} B1
L10	GND	N2	IO154PDB3	P16	GDB0/IO87NPB1
L11	GND	N3	NC	P17	IO85NDB1
L12	GND	N4	GFC2/IO159PDB3	P18	IO85PDB1
L13	GND	N5	IO161NPB3	P19	IO84PDB1
L14	V _{CC}	N6	IO156PPB3	P20	NC
L15	GCC0/IO69NPB1	N7	IO129RSB2	P21	IO81PDB1
L16	GCB1/IO70PPB1	N8	V _{CC} B3	P22	NC
L17	GCA0/IO71NPB1	N9	V _{CC}	R1	NC
L18	IO67NPB1	N10	GND	R2	NC
L19	GCB0/IO70NPB1	N11	GND	R3	V _{CC}
L20	IO77PDB1	N12	GND	R4	IO150PDB3
L21	IO77NDB1	N13	GND	R5	IO151NPB3
L22	IO78NPB1	N14	V _{CC}	R6	IO147NPB3
M1	NC	N15	V _{CC} B1	R7	GEC0/IO146NPB3
M2	IO155NDB3	N16	IO73NPB1	R8	VMV3
M3	IO158NPB3	N17	IO80NPB1	R9	V _{CC} B2
M4	GFA2/IO161PPB3	N18	IO74NPB1	R10	V _{CC} B2
M5	GFA1/IO162PDB3	N19	IO72NDB1	R11	IO117RSB2
M6	V _{CC} PLF	N20	NC	R12	IO110RSB2
M7	IO160NDB3	N21	IO79NPB1	R13	V _{CC} B2
M8	GFB2/IO160PDB3	N22	NC	R14	V _{CC} B2
M9	V _{CC}	P1	NC	R15	VMV2
M10	GND	P2	IO153PDB3	R16	IO94RSB2

484-Pin FBGA		484-Pin FBGA		484-Pin FBGA	
Pin Number	A3P600 Function	Pin Number	A3P600 Function	Pin Number	A3P600 Function
R17	GDB1/IO87PPB1	U9	IO131RSB2	W1	NC
R18	GDC1/IO86PDB1	U10	IO124RSB2	W2	IO148PDB3
R19	IO84NDB1	U11	IO119RSB2	W3	NC
R20	V _{CC}	U12	IO107RSB2	W4	GND
R21	IO81NDB1	U13	IO104RSB2	W5	IO137RSB2
R22	IO82PDB1	U14	IO97RSB2	W6	GEB2/IO142RSB2
T1	IO152PDB3	U15	VMV1	W7	IO134RSB2
T2	IO152NDB3	U16	TCK	W8	IO125RSB2
T3	NC	U17	V _{PUMP}	W9	IO123RSB2
T4	IO150NDB3	U18	TRST	W10	IO118RSB2
T5	IO147PPB3	U19	GDA0/IO88NDB1	W11	IO115RSB2
T6	GEC1/IO146PPB3	U20	NC	W12	IO111RSB2
T7	IO140RSB2	U21	IO83NDB1	W13	IO106RSB2
T8	GNDQ	U22	NC	W14	IO102RSB2
T9	GEA2/IO143RSB2	V1	NC	W15	GDC2/IO91RSB2
T10	IO126RSB2	V2	NC	W16	IO93RSB2
T11	IO120RSB2	V3	GND	W17	GDA2/IO89RSB2
T12	IO108RSB2	V4	GEA1/IO144PDB3	W18	TMS
T13	IO103RSB2	V5	GEA0/IO144NDB3	W19	GND
T14	IO99RSB2	V6	IO139RSB2	W20	NC
T15	GNDQ	V7	GEC2/IO141RSB2	W21	NC
T16	IO92RSB2	V8	IO132RSB2	W22	NC
T17	V _{JTAG}	V9	IO127RSB2	Y1	V _{CC} B3
T18	GDC0/IO86NDB1	V10	IO121RSB2	Y2	IO148NDB3
T19	GDA1/IO88PDB1	V11	IO114RSB2	Y3	NC
T20	NC	V12	IO109RSB2	Y4	NC
T21	IO83PDB1	V13	IO105RSB2	Y5	GND
T22	IO82NDB1	V14	IO98RSB2	Y6	NC
U1	IO149PDB3	V15	IO96RSB2	Y7	NC
U2	IO149NDB3	V16	GDB2/IO90RSB2	Y8	V _{CC}
U3	NC	V17	TDI	Y9	V _{CC}
U4	GEB1/IO145PDB3	V18	GNDQ	Y10	NC
U5	GEB0/IO145NDB3	V19	TDO	Y11	NC
U6	VMV2	V20	GND	Y12	NC
U7	IO138RSB2	V21	NC	Y13	NC
U8	IO136RSB2	V22	NC	Y14	V _{CC}

484-Pin FBGA		484-Pin FBGA	
Pin Number	A3P600 Function	Pin Number	A3P600 Function
Y15	V _{CC}	AB7	IO128RSB2
Y16	NC	AB8	IO122RSB2
Y17	NC	AB9	IO116RSB2
Y18	GND	AB10	NC
Y19	NC	AB11	NC
Y20	NC	AB12	IO113RSB2
Y21	NC	AB13	IO112RSB2
Y22	V _{CC} B1	AB14	NC
AA1	GND	AB15	NC
AA2	V _{CC} B3	AB16	IO100RSB2
AA3	NC	AB17	IO95RSB2
AA4	NC	AB18	NC
AA5	NC	AB19	NC
AA6	IO135RSB2	AB20	V _{CC} B2
AA7	IO133RSB2	AB21	GND
AA8	NC	AB22	GND
AA9	NC		
AA10	NC		
AA11	NC		
AA12	NC		
AA13	NC		
AA14	NC		
AA15	NC		
AA16	IO101RSB2		
AA17	NC		
AA18	NC		
AA19	NC		
AA20	NC		
AA21	V _{CC} B1		
AA22	GND		
AB1	GND		
AB2	GND		
AB3	V _{CC} B2		
AB4	NC		
AB5	NC		
AB6	IO130RSB2		

484-Pin FBGA	
Pin Number	A3P1000 Function
A1	GND
A2	GND
A3	V _{CC} B0
A4	IO07RSB0
A5	IO09RSB0
A6	IO13RSB0
A7	IO18RSB0
A8	IO20RSB0
A9	IO26RSB0
A10	IO32RSB0
A11	IO40RSB0
A12	IO41RSB0
A13	IO53RSB0
A14	IO59RSB0
A15	IO64RSB0
A16	IO65RSB0
A17	IO67RSB0
A18	IO69RSB0
A19	NC
A20	V _{CC} B0
A21	GND
A22	GND
B1	GND
B2	V _{CC} B3
B3	NC
B4	IO06RSB0
B5	IO08RSB0
B6	IO12RSB0
B7	IO15RSB0
B8	IO19RSB0
B9	IO24RSB0
B10	IO31RSB0
B11	IO39RSB0
B12	IO48RSB0
B13	IO54RSB0
B14	IO58RSB0

484-Pin FBGA	
Pin Number	A3P1000 Function
B15	IO63RSB0
B16	IO66RSB0
B17	IO68RSB0
B18	IO70RSB0
B19	NC
B20	NC
B21	V _{CC} B1
B22	GND
C1	V _{CC} B3
C2	IO220PDB3
C3	NC
C4	NC
C5	GND
C6	IO10RSB0
C7	IO14RSB0
C8	V _{CC}
C9	V _{CC}
C10	IO30RSB0
C11	IO37RSB0
C12	IO43RSB0
C13	NC
C14	V _{CC}
C15	V _{CC}
C16	NC
C17	NC
C18	GND
C19	NC
C20	NC
C21	NC
C22	V _{CC} B1
D1	IO219PDB3
D2	IO220NDB3
D3	NC
D4	GND
D5	GAA0/IO00RSB0
D6	GAA1/IO01RSB0

484-Pin FBGA	
Pin Number	A3P1000 Function
D7	GAB0/IO02RSB0
D8	IO16RSB0
D9	IO22RSB0
D10	IO28RSB0
D11	IO35RSB0
D12	IO45RSB0
D13	IO50RSB0
D14	IO55RSB0
D15	IO61RSB0
D16	GBB1/IO75RSB0
D17	GBA0/IO76RSB0
D18	GBA1/IO77RSB0
D19	GND
D20	NC
D21	NC
D22	NC
E1	IO219NDB3
E2	NC
E3	GND
E4	GAB2/IO224PDB3
E5	GAA2/IO225PDB3
E6	GNDQ
E7	GAB1/IO03RSB0
E8	IO17RSB0
E9	IO21RSB0
E10	IO27RSB0
E11	IO34RSB0
E12	IO44RSB0
E13	IO51RSB0
E14	IO57RSB0
E15	GBC1/IO73RSB0
E16	GBB0/IO74RSB0
E17	IO71RSB0
E18	GBA2/IO78PDB1
E19	IO81PDB1
E20	GND

484-Pin FBGA		484-Pin FBGA		484-Pin FBGA	
Pin Number	A3P1000 Function	Pin Number	A3P1000 Function	Pin Number	A3P1000 Function
E21	NC	G13	IO52RSB0	J5	IO218NDB3
E22	IO84PDB1	G14	IO60RSB0	J6	IO216PDB3
F1	NC	G15	GNDQ	J7	IO216NDB3
F2	IO215PDB3	G16	IO80NDB1	J8	V _{CC} B3
F3	IO215NDB3	G17	GBB2/IO79PDB1	J9	GND
F4	IO224NDB3	G18	IO79NDB1	J10	V _{CC}
F5	IO225NDB3	G19	IO82NPB1	J11	V _{CC}
F6	VMV3	G20	IO85PDB1	J12	V _{CC}
F7	IO11RSB0	G21	IO85NDB1	J13	V _{CC}
F8	GAC0/IO04RSB0	G22	NC	J14	GND
F9	GAC1/IO05RSB0	H1	NC	J15	V _{CC} B1
F10	IO25RSB0	H2	NC	J16	IO83NPB1
F11	IO36RSB0	H3	V _{CC}	J17	IO86NPB1
F12	IO42RSB0	H4	IO217PDB3	J18	IO90PPB1
F13	IO49RSB0	H5	IO218PDB3	J19	IO87NDB1
F14	IO56RSB0	H6	IO221NDB3	J20	NC
F15	GBC0/IO72RSB0	H7	IO221PDB3	J21	IO89PDB1
F16	IO62RSB0	H8	VMV0	J22	IO89NDB1
F17	VMV0	H9	V _{CC} B0	K1	IO211PDB3
F18	IO78NDB1	H10	V _{CC} B0	K2	IO211NDB3
F19	IO81NDB1	H11	IO38RSB0	K3	NC
F20	IO82PPB1	H12	IO47RSB0	K4	IO210PPB3
F21	NC	H13	V _{CC} B0	K5	IO213NDB3
F22	IO84NDB1	H14	V _{CC} B0	K6	IO213PDB3
G1	IO214NDB3	H15	VMV1	K7	GFC1/IO209PPB3
G2	IO214PDB3	H16	GBC2/IO80PDB1	K8	V _{CC} B3
G3	NC	H17	IO83PPB1	K9	V _{CC}
G4	IO222NDB3	H18	IO86PPB1	K10	GND
G5	IO222PDB3	H19	IO87PDB1	K11	GND
G6	GAC2/IO223PDB3	H20	V _{CC}	K12	GND
G7	IO223NDB3	H21	NC	K13	GND
G8	GNDQ	H22	NC	K14	V _{CC}
G9	IO23RSB0	J1	IO212NDB3	K15	V _{CC} B1
G10	IO29RSB0	J2	IO212PDB3	K16	GCC1/IO91PPB1
G11	IO33RSB0	J3	NC	K17	IO90NPB1
G12	IO46RSB0	J4	IO217NDB3	K18	IO88PDB1

484-Pin FBGA	
Pin Number	A3P1000 Function
K19	IO88NDB1
K20	IO94NPB1
K21	IO98NDB1
K22	IO98PDB1
L1	NC
L2	IO200PDB3
L3	IO210NPB3
L4	GFB0/IO208NPB3
L5	GFA0/IO207NDB3
L6	GFB1/IO208PPB3
L7	V _{CCOMPLF}
L8	GFC0/IO209NPB3
L9	V _{CC}
L10	GND
L11	GND
L12	GND
L13	GND
L14	V _{CC}
L15	GCC0/IO91NPB1
L16	GCB1/IO92PPB1
L17	GCA0/IO93NPB1
L18	IO96NPB1
L19	GCB0/IO92NPB1
L20	IO97PDB1
L21	IO97NDB1
L22	IO99NPB1
M1	NC
M2	IO200NDB3
M3	IO206NDB3
M4	GFA2/IO206PDB3
M5	GFA1/IO207PDB3
M6	V _{CCPLF}
M7	IO205NDB3
M8	GFB2/IO205PDB3
M9	V _{CC}
M10	GND

484-Pin FBGA	
Pin Number	A3P1000 Function
M11	GND
M12	GND
M13	GND
M14	V _{CC}
M15	GCB2/IO95PPB1
M16	GCA1/IO93PPB1
M17	GCC2/IO96PPB1
M18	IO100PPB1
M19	GCA2/IO94PPB1
M20	IO101PPB1
M21	IO99PPB1
M22	NC
N1	IO201NDB3
N2	IO201PDB3
N3	NC
N4	GFC2/IO204PDB3
N5	IO204NDB3
N6	IO203NDB3
N7	IO203PDB3
N8	V _{CCB3}
N9	V _{CC}
N10	GND
N11	GND
N12	GND
N13	GND
N14	V _{CC}
N15	V _{CCB1}
N16	IO95NPB1
N17	IO100NPB1
N18	IO102NDB1
N19	IO102PDB1
N20	NC
N21	IO101NPB1
N22	IO103PDB1
P1	NC
P2	IO199PDB3

484-Pin FBGA	
Pin Number	A3P1000 Function
P3	IO199NDB3
P4	IO202NDB3
P5	IO202PDB3
P6	IO196PPB3
P7	IO193PPB3
P8	V _{CCB3}
P9	GND
P10	V _{CC}
P11	V _{CC}
P12	V _{CC}
P13	V _{CC}
P14	GND
P15	V _{CCB1}
P16	GDB0/IO112NPB1
P17	IO106NDB1
P18	IO106PDB1
P19	IO107PDB1
P20	NC
P21	IO104PDB1
P22	IO103NDB1
R1	NC
R2	IO197PPB3
R3	V _{CC}
R4	IO197NPB3
R5	IO196NPB3
R6	IO193NPB3
R7	GEC0/IO190NPB3
R8	VMV3
R9	V _{CCB2}
R10	V _{CCB2}
R11	IO147RSB2
R12	IO136RSB2
R13	V _{CCB2}
R14	V _{CCB2}
R15	VMV2
R16	IO110NDB1

484-Pin FBGA		484-Pin FBGA		484-Pin FBGA	
Pin Number	A3P1000 Function	Pin Number	A3P1000 Function	Pin Number	A3P1000 Function
R17	GDB1/IO112PPB1	U9	IO165RSB2	W1	NC
R18	GDC1/IO111PDB1	U10	IO159RSB2	W2	IO191PDB3
R19	IO107NDB1	U11	IO151RSB2	W3	NC
R20	V _{CC}	U12	IO137RSB2	W4	GND
R21	IO104NDB1	U13	IO134RSB2	W5	IO183RSB2
R22	IO105PDB1	U14	IO128RSB2	W6	GEB2/IO186RSB2
T1	IO198PDB3	U15	VMV1	W7	IO172RSB2
T2	IO198NDB3	U16	TCK	W8	IO170RSB2
T3	NC	U17	V _{PUMP}	W9	IO164RSB2
T4	IO194PPB3	U18	TRST	W10	IO158RSB2
T5	IO192PPB3	U19	GDA0/IO113NDB1	W11	IO153RSB2
T6	GEC1/IO190PPB3	U20	NC	W12	IO142RSB2
T7	IO192NPB3	U21	IO108NDB1	W13	IO135RSB2
T8	GNDQ	U22	IO109PDB1	W14	IO130RSB2
T9	GEA2/IO187RSB2	V1	NC	W15	GDC2/IO116RSB2
T10	IO161RSB2	V2	NC	W16	IO120RSB2
T11	IO155RSB2	V3	GND	W17	GDA2/IO114RSB2
T12	IO141RSB2	V4	GEA1/IO188PDB3	W18	TMS
T13	IO129RSB2	V5	GEA0/IO188NDB3	W19	GND
T14	IO124RSB2	V6	IO184RSB2	W20	NC
T15	GNDQ	V7	GEC2/IO185RSB2	W21	NC
T16	IO110PDB1	V8	IO168RSB2	W22	NC
T17	V _{JTAG}	V9	IO163RSB2	Y1	V _{CC} B3
T18	GDC0/IO111NDB1	V10	IO157RSB2	Y2	IO191NDB3
T19	GDA1/IO113PDB1	V11	IO149RSB2	Y3	NC
T20	NC	V12	IO143RSB2	Y4	IO182RSB2
T21	IO108PDB1	V13	IO138RSB2	Y5	GND
T22	IO105NDB1	V14	IO131RSB2	Y6	IO177RSB2
U1	IO195PDB3	V15	IO125RSB2	Y7	IO174RSB2
U2	IO195NDB3	V16	GDB2/IO115RSB2	Y8	V _{CC}
U3	IO194NPB3	V17	TDI	Y9	V _{CC}
U4	GEB1/IO189PDB3	V18	GNDQ	Y10	IO154RSB2
U5	GEB0/IO189NDB3	V19	TDO	Y11	IO148RSB2
U6	VMV2	V20	GND	Y12	IO140RSB2
U7	IO179RSB2	V21	NC	Y13	NC
U8	IO171RSB2	V22	IO109NDB1	Y14	V _{CC}

484-Pin FBGA	
Pin Number	A3P1000 Function
Y15	V _{CC}
Y16	NC
Y17	NC
Y18	GND
Y19	NC
Y20	NC
Y21	NC
Y22	V _{CC} B1
AA1	GND
AA2	V _{CC} B3
AA3	NC
AA4	IO181RSB2
AA5	IO178RSB2
AA6	IO175RSB2
AA7	IO169RSB2
AA8	IO166RSB2
AA9	IO160RSB2
AA10	IO152RSB2
AA11	IO146RSB2
AA12	IO139RSB2
AA13	IO133RSB2
AA14	NC
AA15	NC
AA16	IO122RSB2
AA17	IO119RSB2
AA18	IO117RSB2
AA19	NC
AA20	NC
AA21	V _{CC} B1
AA22	GND
AB1	GND
AB2	GND
AB3	V _{CC} B2
AB4	IO180RSB2
AB5	IO176RSB2
AB6	IO173RSB2

484-Pin FBGA	
Pin Number	A3P1000 Function
AB7	IO167RSB2
AB8	IO162RSB2
AB9	IO156RSB2
AB10	IO150RSB2
AB11	IO145RSB2
AB12	IO144RSB2
AB13	IO132RSB2
AB14	IO127RSB2
AB15	IO126RSB2
AB16	IO123RSB2
AB17	IO121RSB2
AB18	IO118RSB2
AB19	NC
AB20	V _{CC} B2
AB21	GND
AB22	GND

Part Number and Revision Date

Part Number 51700097-003-4

Revised August 2008

List of Changes

The following table lists critical changes that were made in the current version of the document.

Previous Version	Changes in Current Version (v1.3)	Page
v1.2 (February 2008)	Pin numbers were added to the "68-Pin QFN" package diagram. Note 2 was added below the diagram.	3-1
	The "132-Pin QFN" package diagram was updated to include D1 to D4. In addition, note 1 was changed from top view to bottom view, and note 2 is new.	3-3
v1.1 (January 2008)	The "68-Pin QFN" section is new.	3-1
v1.0 (January 2008)	In the "100-Pin VQFP" A3P030 pin table, the function of pin 63 was incorrect and changed from IO39RSB0 to GDB0/IO38RSB0.	3-12
v2.2 (July 2007)	This document was previously in datasheet v2.2. As a result of moving to the handbook format, Actel has restarted the version numbers. The new version number is v1.0.	N/A
v2.0 (April 2007)	The following pin tables were updated for A3P600: "208-Pin PQFP", "256-Pin FBGA", and "484-Pin FBGA". The "144-Pin FBGA" table for A3P600 is new.	4-27 – 4-63
Advance v0.7 (January 2007)	Notes were added to the package diagrams identifying if they were top or bottom view.	N/A
	The A3P030 "132-Pin QFN" table is new.	4-2
	The A3P060 "132-Pin QFN" table is new.	4-4
	The A3P125 "132-Pin QFN" table is new.	4-6
	The A3P250 "132-Pin QFN" table is new.	4-8
Advance v0.5 (January 2006)	The A3P030 "100-Pin VQFP" table is new.	4-11
	The A3P060 "100-Pin VQFP" pin table was updated.	4-13
	The A3P125 "100-Pin VQFP" pin table was updated.	4-13
	The A3P060 "144-Pin TQFP" pin table was updated.	4-16
	The A3P125 "144-Pin TQFP" pin table was updated.	4-18
	The A3P125 "208-Pin PQFP" pin table was updated.	4-21
	The A3P400 "208-Pin PQFP" pin table was updated.	4-25
	The A3P060 "144-Pin FBGA" pin table was updated.	4-32
	The A3P125 "144-Pin FBGA" pin table is new.	4-34
	The A3P400 "144-Pin FBGA" is new.	4-38
	The A3P400 "256-Pin FBGA" was updated.	4-48
	The A3P1000 "256-Pin FBGA" was updated.	4-54
	The A3P400 "484-Pin FBGA" was updated.	4-58
The A3P1000 "484-Pin FBGA" was updated.	4-68	

Previous Version	Changes in Current Version (v1.3)	Page
Advance v0.2 (continued)	The A3P250 "100-Pin VQFP*" pin table was updated.	4-14
	The A3P250 "208-Pin PQFP*" pin table was updated.	4-23
	The A3P1000 "208-Pin PQFP*" pin table was updated.	4-29
	The A3P250 "144-Pin FBGA*" pin table was updated.	4-36
	The A3P1000 "144-Pin FBGA*" pin table was updated.	4-32
	The A3P250 "256-Pin FBGA*" pin table was updated.	4-45
	The A3P1000 "256-Pin FBGA*" pin table was updated.	4-54
	The A3P1000 "484-Pin FBGA*" pin table was updated.	4-68

Datasheet Categories

Categories

In order to provide the latest information to designers, some datasheets are published before data has been fully characterized. Datasheets are designated as "Product Brief," "Advance," "Preliminary," and "Production." The definition of these categories are as follows:

Product Brief

The product brief is a summarized version of a datasheet (advance or production) and contains general product information. This document gives an overview of specific device and family information.

Advance

This version contains initial estimated information based on simulation, other products, devices, or speed grades. This information can be used as estimates, but not for production. This label only applies to the DC and Switching Characteristics chapter of the datasheet and will only be used when the data has not been fully characterized.

Preliminary

The datasheet contains information based on simulation and/or initial characterization. The information is believed to be correct, but changes are possible.

Unmarked (production)

This version contains information that is considered to be final.

Export Administration Regulations (EAR)

The products described in this document are subject to the Export Administration Regulations (EAR). They could require an approved export license prior to export from the United States. An export includes release of product or disclosure of technology to a foreign national inside or outside the United States.

Actel Safety Critical, Life Support, and High-Reliability Applications Policy

The Actel products described in this advance status document may not have completed Actel's qualification process. Actel may amend or enhance products during the product introduction and qualification process, resulting in changes in device functionality or performance. It is the responsibility of each customer to ensure the fitness of any Actel product (but especially a new product) for a particular purpose, including appropriateness for safety-critical, life-support, and other high-reliability applications. Consult Actel's Terms and Conditions for specific liability exclusions relating to life-support applications. A reliability report covering all of Actel's products is available on the Actel website at http://www.actel.com/documents/ORT_Report.pdf. Actel also offers a variety of enhanced qualification and lot acceptance screening procedures. Contact your local Actel sales office for additional reliability information.

Actel and the Actel logo are registered trademarks of Actel Corporation.
All other trademarks are the property of their owners.



www.actel.com

Actel Corporation

2061 Stierlin Court
Mountain View, CA
94043-4655 USA

Phone 650.318.4200

Fax 650.318.4600

Actel Europe Ltd.

River Court, Meadows Business Park
Station Approach, Blackwater
Camberley Surrey GU17 9AB
United Kingdom

Phone +44 (0) 1276 609 300

Fax +44 (0) 1276 607 540

Actel Japan

EXOS Ebisu Building 4F
1-24-14 Ebisu Shibuya-ku
Tokyo 150 Japan

Phone +81.03.3445.7671

Fax +81.03.3445.7668

<http://jp.actel.com>

Actel Hong Kong

Room 2107, China Resources Building
26 Harbour Road
Wanchai, Hong Kong

Phone +852 2185 6460

Fax +852 2185 6488

www.actel.com.cn

51700097-005-5/8.08

