

524,288 WORD×8 BIT CMOS UV ERASABLE AND ELECTRICALLY PROGRAMMABLE READ ONLY MEMORY

DESCRIPTION

The TC544000P/F is a 524,288 word × 8 bit one time programmable read only memory, and molded in a 32 pin plastic package. The access time of TC544000P/F is 120ns/150ns and has low power standby mode which reduces the power dissipation without increasing access time.

The electrical characteristics and programming method are the same as U.V. EPROM TC574000D's once programmed, the TC544000P/F can not be erased because of using plastic DIP without transparent window.

FEATURES

- Peripheral circuit : CMOS
- Memory cell : N-MOS
- Access time

	- 12	- 150
V _{CC}	5V ± 5%	5V ± 10%
Temp	0°C~70°C	
t _{ACC}	120ns	150ns
- Low power dissipation
 - Active : 60mA/8.3MHz
 - Standby: 100µA (Ta=70°C)
- High speed programming operation
- Single 5V power supply
- Full static operation
- Input and output TTL compatible
- JEDEC standard 32 pin
- TC544000P : DIP32-P-600
- TC544000F : SOP32-P-525

-12 are satisfied with the specification of -150.

PIN CONNECTION (TOP VIEW)

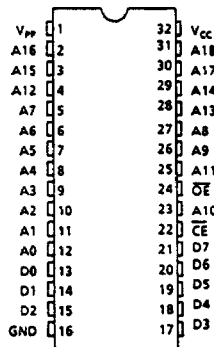

TC544000P/F

PIN NAMES

A0~A18	Address Inputs
D0~D7	Outputs (inputs)
CE	Chip Enable Input
OE	Output Enable Input
V _{CC}	V _{CC} Supply Voltage
V _{PP}	Program Supply Voltage
GND	Ground

BLOCK DIAGRAM

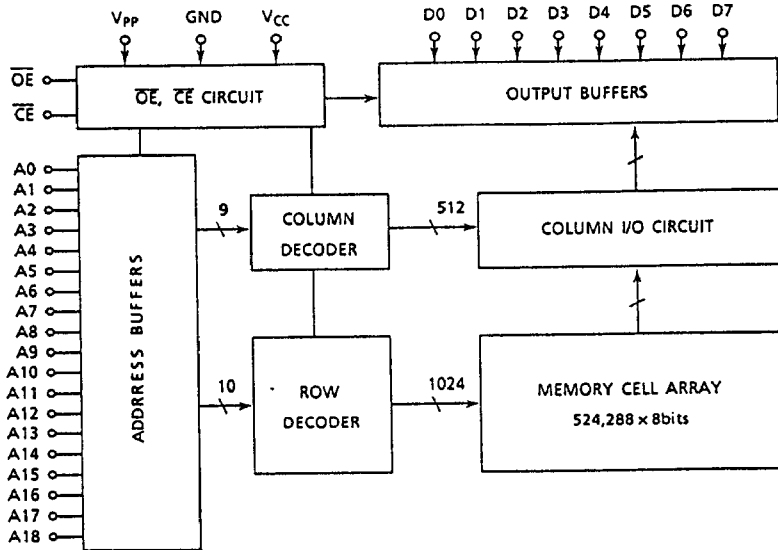

MODE SELECTION

MODE \ PIN	\overline{CE}	\overline{OE}	V_{PP}	V_{CC}	D0~D7	Power
Read	L	L	5V	5V	Data Out	Active
Output Deselect	*	H			High Impedance	
Standby	H	*			High Impedance	Standby
Program	L	H	12.50V	6.25V	Data In	Active
Program Inhibit	H	H			High Impedance	
Program Verify	*	L			Data Out	

* : H or L

MAXIMUM RATINGS

SYMBOL	ITEM	RATING	UNIT
V_{CC}	V_{CC} Power Supply Voltage	-0.6~7.0	V
V_{PP}	Program Supply Voltage	-0.6~14.0	V
V_{IN}	Input Voltage	-0.6~7.0	V
$V_{IN}(A9)$	Input Voltage (A9)	-0.6~13.5	V
V_{IO}	Input/Output Voltage	-0.6~ $V_{CC} + 0.5$	V
P_D	Power Dissipation	1.5	W
T_{SOLDER}	Soldering Temperature · Time	260 · 10	°C · sec
T_{strg}	Storage Temperature	-65~125	°C
T_{opr}	Operating Temperature	0~70	°C

READ OPERATION

DC RECOMMENDED OPERATING CONDITIONS

SYMBOL	PARAMETER	TC544000P/F-12	TC544000P/F-150
V_{IH}	Input High Voltage	$2.2V \sim V_{CC} + 0.3V$	$2.2V \sim V_{CC} + 0.3V$
V_{IL}	Input Low Voltage	$-0.3V \sim 0.8V$	$0.3V \sim 0.8V$
V_{CC}	V_{CC} Power Supply Voltage	$5V \pm 5\%$	$5V \pm 10\%$
V_{PP}	V_{PP} Power Supply Voltage	$V_{CC} - 0.6V \sim V_{CC} + 0.6V$	$V_{CC} - 0.6V \sim V_{CC} + 0.6V$

DC AND OPERATING CHARACTERISTICS ($T_a = 0 \sim 70^\circ\text{C}$)

SIMBOL	PARAMETER	TEST CONDITION	MIN.	TYP.	MAX.	UNIT	
I_{LI}	Input Current	$V_{IN} = 0 \sim V_{CC}$	-	-	± 10	μA	
I_{CCO1}	Operating Current	$\overline{CE} = V_{IL}$ $I_{OUT} = 0\text{mA}$	$f = 8.3\text{MHz}$	-	-	60	mA
			$f = 6.7\text{MHz}$	-	-	50	
I_{CCO2}			$f = 1\text{MHz}$	-	-	15	
I_{CCS1}	Standby Current	$\overline{CE} = V_{IH}$	-	-	1	mA	
I_{CCS2}		$\overline{CE} = V_{CC} - 0.2V$	-	-	100	μA	
V_{OH}	Output High Voltage	$I_{OH} = -400\mu\text{A}$	2.4	-	-	V	
V_{OL}	Output Low Voltage	$I_{OL} = 2.1\text{mA}$	-	-	0.4	V	
I_{PP1}	V_{PP} Current	$V_{PP} = V_{CC} \pm 0.6V$	-	-	± 10	μA	
I_{LO}	Output Leakage Current	$V_{OUT} = 0.4V \sim V_{CC}$	-	-	± 10	μA	

AC CHARACTERISTICS ($T_a = 0 \sim 70^\circ\text{C}$, $V_{PP} = V_{CC} \pm 0.6V$)

SIMBOL	PARAMETER	TEST CONDITION	TC544000P/F-12		TC544000P/F-150		UNIT
			MIN.	MAX.	MIN.	MAX.	
t_{ACC}	Address Access Time	$\overline{CE} = \overline{OE} = V_{IL}$	-	120	-	150	ns
t_{CE}	\overline{CE} to Output Valid	$\overline{OE} = V_{IL}$	-	120	-	150	ns
t_{OE}	\overline{OE} to Output Valid	$\overline{CE} = V_{IL}$	-	60	-	70	ns
t_{DF1}	\overline{CE} to Output in High-Z	$\overline{OE} = V_{IL}$	0	50	0	60	ns
t_{DF2}	\overline{OE} to Output in High-Z	$\overline{CE} = V_{IL}$	0	50	0	60	ns
t_{OH}	Output Data Hold Time	$\overline{CE} = \overline{OE} = V_{IL}$	0	-	0	-	ns

TC544000P/F-12 are satisfied with the specification of TC544000P/F-150

AC TEST CONDITIONS

- Output Load : 1 TTL Gate and $C_L = 100\text{pF}$
- Input Pulse Rise and Fall Times : 10ns Max.
- Input Pulse Levels : 0.45V~2.4V
- Timing Measurement Reference Level : Inputs 0.8V and 2.2V, Outputs 0.8V and 2.0V

CAPACITANCE* ($T_a = 25^\circ\text{C}$, $f = 1\text{MHz}$)

SYMBOL	PARAMETER	TEST CONDITION	MIN.	MAX.	UNIT
C_{IN}	Input Capacitance	$V_{IN} = 0V$	-	9	PF
C_{OUT}	Output Capacitance	$V_{OUT} = 0V$	-	13	

* This parameter is periodically sampled is not 100% tested.

TIMING WAVEFORMS (READ)

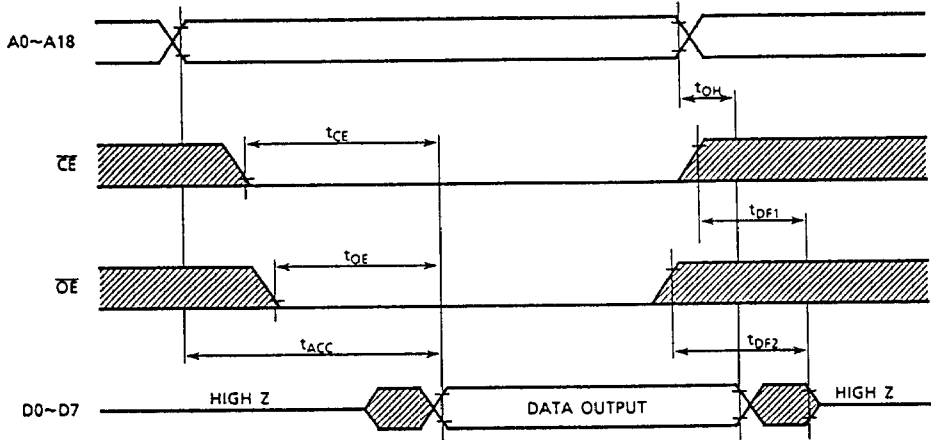

HIGH SPEED PROGRAM OPERATION

DC RECOMMENDED OPERATING CONDITIONS

SYMBOL	PARAMETER	MIN.	TYP.	MAX.	UNIT
V_{IH}	Input High Voltage	2.2	-	$V_{CC} + 1.0$	V
V_{IL}	Input Low Voltage	-0.3	-	0.8	V
V_{CC}	V_{CC} Power Supply Voltage	6.00	6.25	6.50	V
V_{PP}	V_{PP} Power Supply Voltage	12.20	12.50	12.80	V

DC AND OPERATING CHARACTERISTICS ($T_a = 25 \pm 5^\circ\text{C}$, $V_{CC} = 6.25\text{V} \pm 0.25\text{V}$, $V_{PP} = 12.50\text{V} \pm 0.30\text{V}$)

SYMBOL	PARAMETER	TEST CONDITION	MIN.	TYP.	MAX.	UNIT
I_{LI}	Input Current	$V_{IN} = 0 - V_{CC}$	-	-	± 10	μA
V_{OH}	Output High Voltage	$I_{OH} = -400\mu\text{A}$	2.4	-	-	V
V_{OL}	Output Low Voltage	$I_{OL} = 2.1\text{mA}$	-	-	0.4	V
I_{CC}	V_{CC} Supply Current	-	-	-	30	mA
I_{PP2}	V_{PP} Supply Current	$V_{PP} = 12.8\text{V}$	-	-	50	mA

AC PROGRAMMING CHARACTERISTICS ($T_a = 25 \pm 5^\circ\text{C}$, $V_{CC} = 6.25\text{V} \pm 0.25\text{V}$, $V_{PP} = 12.50\text{V} \pm 0.30\text{V}$)

SYMBOL	PARAMETER	TEST CONDITION	MIN.	TYP.	MAX.	UNIT
t_{AS}	Address Setup Time	-	2	-	-	μs
t_{AH}	Address Hold Time	-	2	-	-	μs
t_{CES}	\overline{CE} Setup Time	-	0	-	-	μs
t_{CEH}	\overline{CE} Hold Time	-	0	-	-	μs
t_{OES}	\overline{OE} Set up Time	-	2	-	-	μs
t_{OS}	Data Set up Time	-	2	-	-	μs
t_{OH}	Data Hold Time	-	2	-	-	μs
t_{VPS}	V_{PP} Set up Time	-	2	-	-	μs
t_{VCS}	V_{CC} Set up Time	-	2	-	-	μs
t_{PW}	Program Pulse Width	$\overline{CE} = V_{IL}$, $\overline{OE} = V_{IH}$	45	50	55	μs
t_{OE}	\overline{OE} to Output Valid	$\overline{CE} = V_{IH}$	-	-	100	ns
t_{DFP}	\overline{OE} to Output in High-Z	$\overline{CE} = V_{IH}$	-	-	90	ns

AC TEST CONDITIONS

- Output Load : 1 TTL Gate and C_L (100pF)
- Input Pulse Rise and Fall Time : 10ns Max.
- Input Pulse Levels : 0.45V~2.4V
- Timing Measurement Reference Level : Input 0.8V and 2.2V, Output 0.8V and 2.0V

TIMING WAVEFORMS (PROGRAM)

HIGH SPEED PROGRAM OPERATION

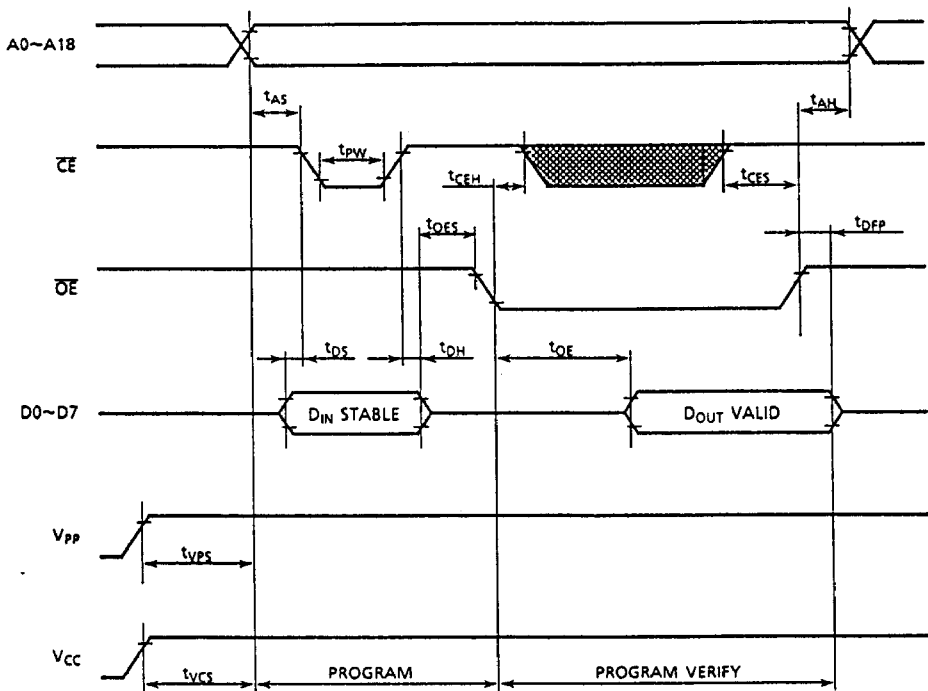

- Note 1. VCC must be applied simultaneously or before Vpp and cut off simultaneously or after Vpp.
2. Removing the device from socket and setting the device in socket with VPP=12.50V may cause permanent damage to the device.
3. The VPP supply voltage is permitted up to 14V for program operation. So the voltage over 14V should not be applied to the VPP terminal. When the switching pulse voltage is applied to the VPP terminal, the overshoot voltage of its pulse should not be exceeded 14V.

OPERATION INFORMATION

The TC544000P/F's six operation modes are listed in the following table.
Mode selection can be achieved by applying TTL level signal to all inputs.

MODE		PIN NAMES (NUMBER)		\overline{CE} (22)	\overline{OE} (24)	V_{PP} (1)	V_{CC} (32)	D0-D7 (13-15, 17-21)	POWER
Read Operation ($T_a = 0 \sim 70^\circ\text{C}$)	Read	L	L	5V	5V	Data Out	Active		
	Output Deselet	*	H			High Impedance			
	Standby	H	*			High Impedance		Standby	
Program Operation ($T_a = 25 \pm 5^\circ\text{C}$)	Program	L	H	12.50V	6.25V	Data In	Active		
	Program Inhibit	H	H			High Impedance			
	Program Verify	*	L			Data Out			

Note : H ; V_{IH} , L : V_{IL} , * : V_{IH} or V_{IL}

READ MODE

The TC544000P/F has two control functions. The chip enable (\overline{CE}) controls the operation power and should be used for device selection. The output enable (\overline{OE}) controls the output buffers, independent of device selection. Assuming that $\overline{CE} = \overline{OE} = V_{IL}$, the output data is valid at the outputs after address access time from stabilizing of all addresses. The \overline{CE} to output valid (t_{CE}) is equal to the address access time (t_{ACC}).

Assuming that $\overline{CE} = V_{IL}$ and all addresses are valid, the output data is valid at the outputs after t_{OE} from the falling edge of \overline{OE} .

OUTPUT DESELECT MODE

Assuming that $\overline{CE} = V_{IH}$ or $\overline{OE} = V_{IH}$, the outputs will be in a high impedance state. So two or more TC544000P/F's can be connected together on a common bus line. When \overline{CE} is decoded for device selection, all deselected devices are in low power standby mode.

STANDBY MODE

The TC544000P/F has a low power standby mode controlled by the \overline{CE} signal. By applying a high level to the \overline{CE} input, the TC544000P/F is placed in the standby mode which reduce the operating current to 100 μA by applying MOS-high level (V_{CC}) and then the outputs are in a high impedance state, independent of the \overline{OE} inputs.

PROGRAM MODE

Initially, when received by customers, all bits of the TC544000P/F are in the "1" state which is erased state. Therefore the program operation is to introduce "0's" data into the desired bit locations by electrically programming. The TC544000P/F is in the programming mode when the V_{pp} input is at 12.50V and \overline{CE} is at Low under $\overline{OE}=V_{IH}$.

The TC544000P/F can be programmed any location at any time either individually, sequentially, or at random.

PROGRAM VERIFY MODE

The verify mode is to check that desired data is correctly programmed on the programmed bits. The verify is accomplished with \overline{OE} at V_{IL} .

PROGRAM INHIBIT MODE

Under the condition that the program voltage (+12.50V) is applied to V_{pp} terminal, a high level \overline{CE} and \overline{OE} input inhibits the TC544000P/F from being programmed.

Programming of two or more TC544000P/F's in parallel with different data is easily accomplished. That is, all inputs except for \overline{CE} and \overline{OE} may be commonly connected, and a low level program pulse is applied to the \overline{CE} of the desired device only and high level signal is applied to the other devices.

HIGH SPEED PROGRAM MODE

The device is set up in the high speed programming mode when the programming voltage (+12.50V) is applied to the V_{pp} terminal with $V_{CC}=6.25V$.

The programming is achieved by applying a single low level 50 μ s pulse to the \overline{CE} input after addresses and data are stable. Then the programmed data is verified by using Program Verify Mode. If the programmed data is not correct, another program pulse of 50 μ s is applied and then the programmed data is verified. This should be repeated until the program operates correctly (max. 25 times).

After correctly programming the selected address, the additional program pulse with width of 1 time more than that needed for initial programming is applied.

When programming has been completed, the data in all addresses should be verified with $V_{CC}=V_{pp}=5V$.

HIGH SPEED PROGRAM MODE

FLOW CHART

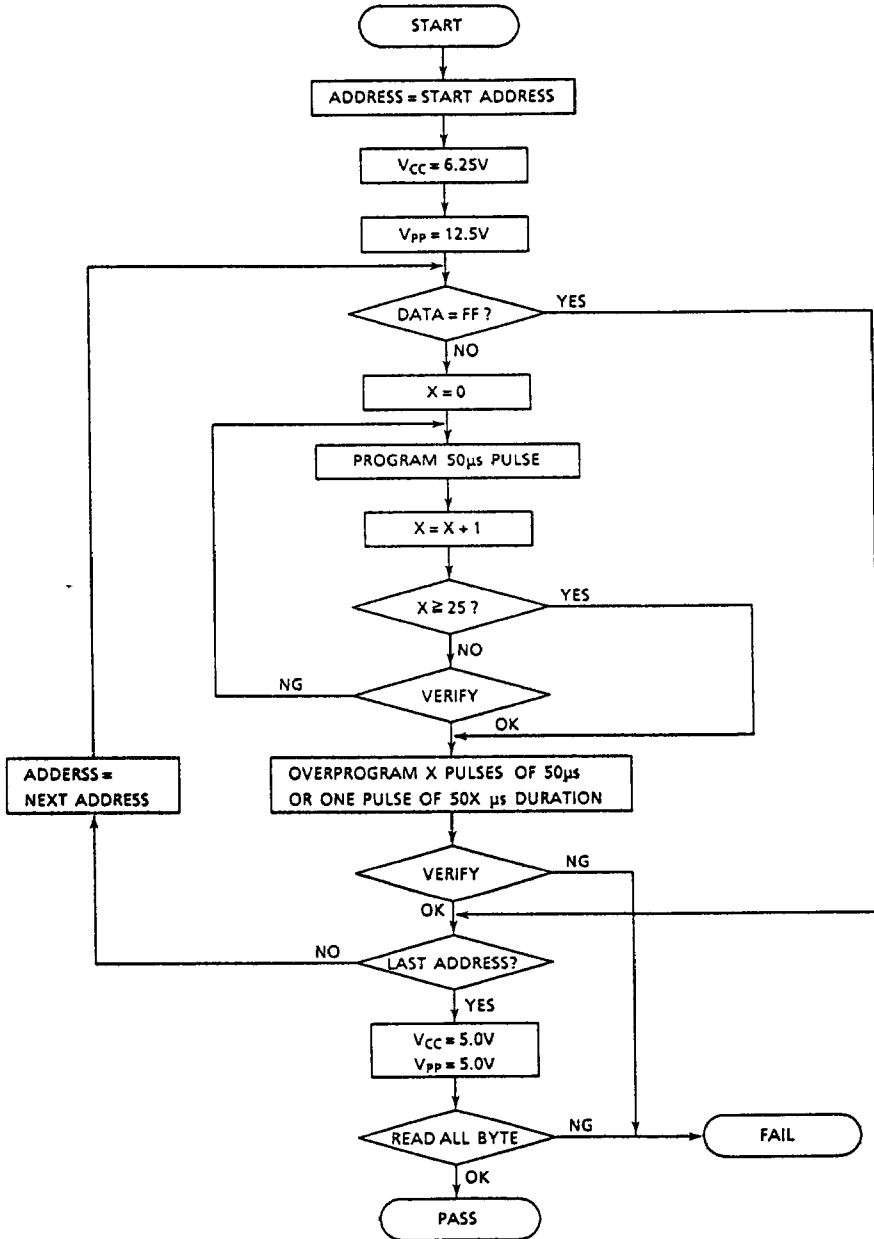

ELECTRIC SIGNATURE MODE

Electric signature mode allows to read out a code from TC544000P/F which identifies its manufacturer and device type.

The programming equipment may reads out manufacturer code and device code from TC544000P/F by using this mode before program operation and automatically set program voltage (V_{pp}) and algorithm.

Electric Signature mode is set up when 12V is applied to address line A9 and the rest of address lines is set to V_{IL} in read operation. Data output in this conditions is manufacturer code. Device code is identified when address A0 is set to V_{IH} .

These two codes possess an odd parity with the parity bit of MSB (D7).

The following table shows electric signature of TC544000P/F.

SIGNATURE \ PINS	A0	D7	D6	D5	D4	D3	D2	D1	D0	HEX. DATA
Manufacturer Code	V_{IL}	1	0	0	1	1	0	0	0	98
Device Code	V_{IH}	1	0	0	0	1	1	0	0	8C

Notes: A9=12V±0.5V

A1~A8, A10~A18, \overline{CE} , \overline{OE} = V_{IL} .

OUTLINE DRAWINGS

- Plastic DIP

DIP32-P-600

Unit : mm

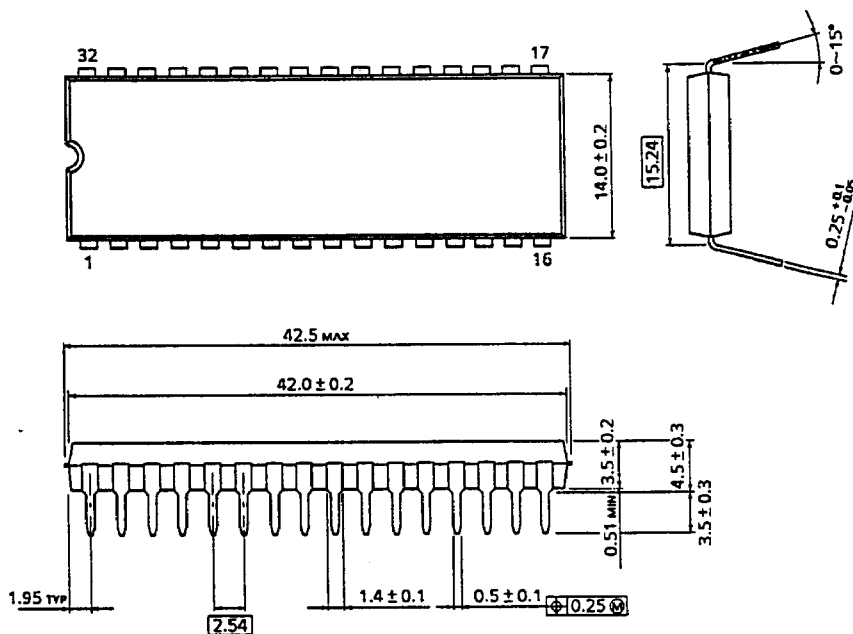

Weight : 4.25g (TYP.)

Note : Package width and length do not include mold protrusion, allowable mode protrusion is 0.15mm.

TC544000P/F-12, -150

OUTLINE DRAWINGS

- Plastic SOP

SOP32-P-525

Unit : mm

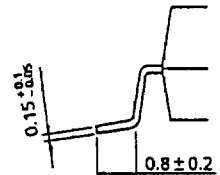
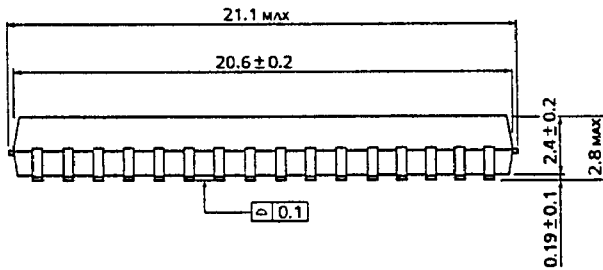
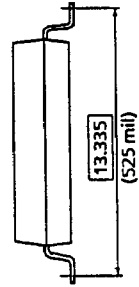
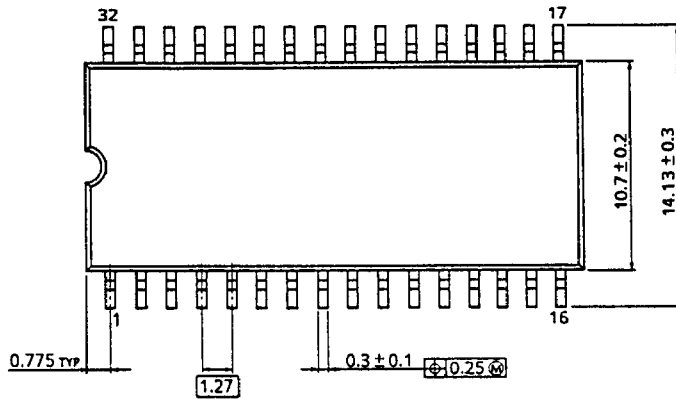

Weight : 1.10g (TYP.)

Note : Package width and length do not include mold protrusion, allowable mold protrusion is 0.15mm.