

# PTF 10159

## 120 Watts, 470–860 MHz

### GOLDMOS™ Field Effect Transistor

#### Description

The PTF 10159 is an internally matched, common source N-channel enhancement-mode lateral MOSFET intended for large signal television amplifier applications from 470 to 860 MHz. It is rated at 120 watts power output. Nitride surface passivation and full gold metallization ensure excellent device lifetime and reliability.

- **INTERNALLY MATCHED**
- **Performance at 860 MHz, 32 Volts**
  - Output Power = 120 Watts Typ
  - Power Gain = 14.0 dB Typ
  - Efficiency = 50% Typ
- **Performance at 860 MHz, 28 Volts**
  - Output Power = 100 Watts
  - Power Gain = 14.0 dB Typ
  - Efficiency = 50% Typ
- **Full Gold Metallization**
- **Silicon Nitride Passivated**
- **Back Side Common Source**
- **100% Lot Traceability**

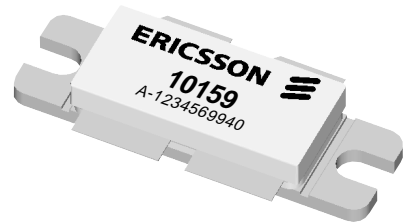
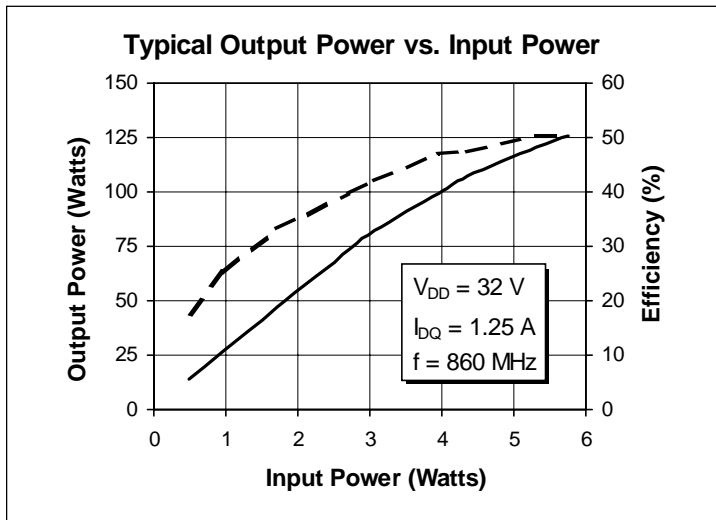

Package 20240

#### RF Specifications (100% Tested)

Characteristic	Symbol	Min	Typ	Max	Units
<b>Gain</b> ( $V_{DD} = 32\text{ V}$ , $P_{OUT} = 120\text{ W}$ , $I_{DQ} = 1.3\text{ A Total}$ , $f = 860\text{ MHz}$ )	$G_{ps}$	12.0	14.0	—	dB
<b>Drain Efficiency</b> ( $V_{DD} = 32\text{ V}$ , $P_{OUT} = 120\text{ W}$ , $I_{DQ} = 1.3\text{ A Total}$ , $f = 860\text{ MHz}$ )	$\eta$	45	50	—	%
<b>Power Output at 1 dB Compression</b> ( $V_{DD} = 32\text{ V}$ , $I_{DQ} = 1.3\text{ A Total}$ , $f = 860\text{ MHz}$ )	P-1dB	115	125	—	Watts
<b>Load Mismatch Tolerance</b> ( $V_{DD} = 32\text{ V}$ , $P_{OUT} = 120\text{ W}$ , $I_{DQ} = 1.3\text{ A Total}$ , $f = 860.0\text{ MHz}$ — all phase angles at frequency of test)	$\Psi$	—	—	5:1	—

All published data at  $T_{CASE} = 25^\circ\text{C}$  unless otherwise indicated.

## Electrical Characteristics (100% Tested)

Characteristic	Conditions	Symbol	Min	Typ	Max	Units
Drain-Source Breakdown Voltage	$V_{GS} = 0\text{ V}, I_D = 5\text{ mA}$	$V_{(BR)DSS}$	65	—	—	Volts
Drain-Source Leakage Current	$V_{DS} = 28\text{ V}, V_{GS} = 0\text{ V}$	$I_{DSS}$	—	—	1.0	mA
Gate Threshold Voltage	$V_{DS} = 10\text{ V}, I_D = 75\text{ mA}$	$V_{GS(th)}$	3.0	—	5.0	Volts
Forward Transconductance	$V_{DS} = 10\text{ V}, I_D = 3\text{ A}$	$g_{fs}$	—	2.5	—	Siemens

## Maximum Ratings

Parameter	Symbol	Value	Unit
Drain-Source Voltage <sup>(1)</sup>	$V_{DSS}$	65	Vdc
Gate-Source Voltage <sup>(1)</sup>	$V_{GS}$	$\pm 20$	Vdc
Operating Junction Temperature	$T_J$	200	$^{\circ}\text{C}$
Total Device Dissipation at Above 25 $^{\circ}\text{C}$ derate by	$P_D$	290 1.67	Watts $\text{W}/^{\circ}\text{C}$
Storage Range	$T_{STG}$	-40 to +150	$^{\circ}\text{C}$
Thermal Resistance ( $T_{CASE} = 70^{\circ}\text{C}$ )	$R_{\theta JC}$	0.6	$^{\circ}\text{C}/\text{W}$

<sup>(1)</sup> per side

## Typical Performance

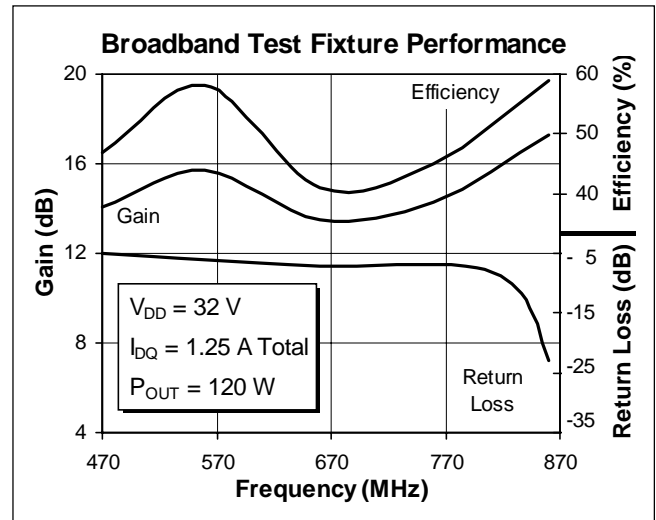
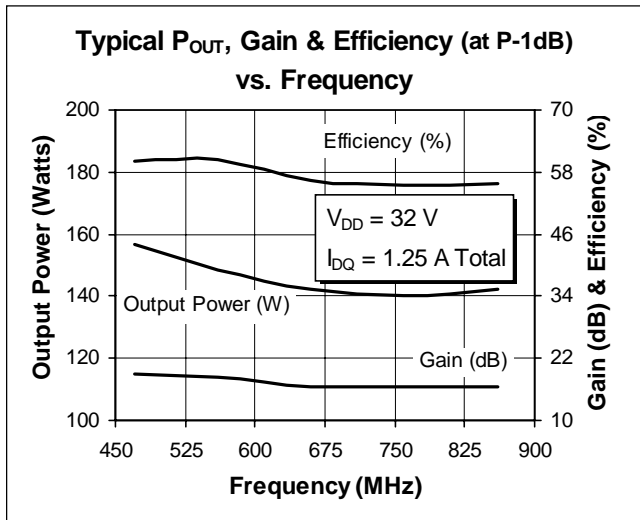

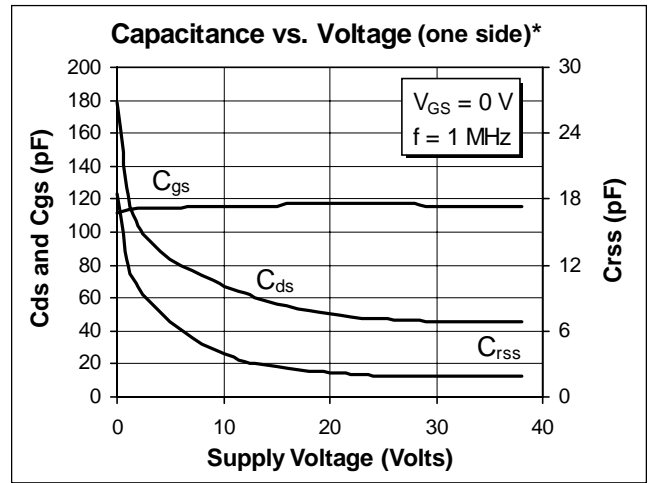
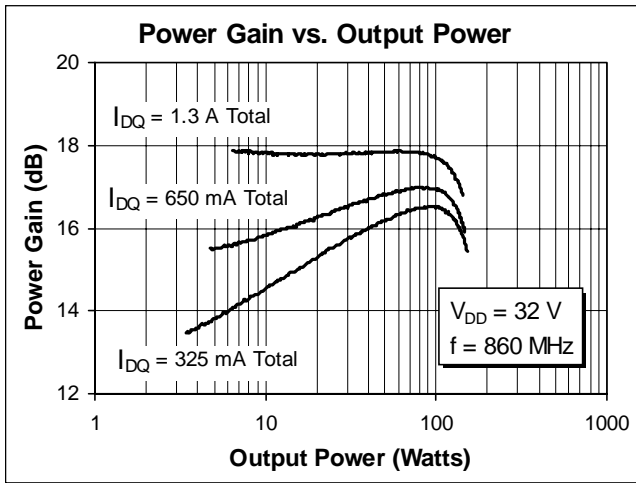
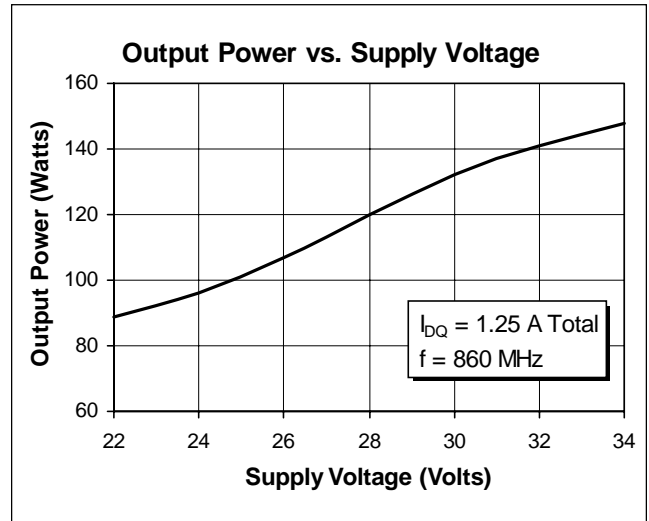
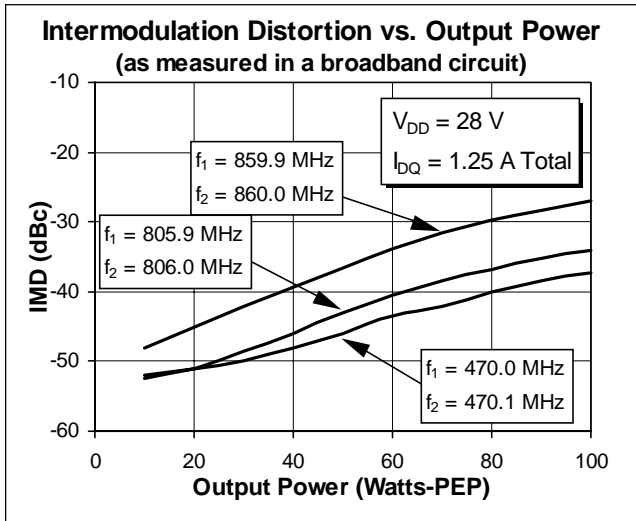

\*This part is internally matched. Measurements of the finished product will not yield these figures.

**Impedance Data**

$V_{DD} = 32\text{ V}$ ,  $P_{OUT} = 120\text{ W}$ ,  $I_{DQ} = 1.3\text{ A Total}$

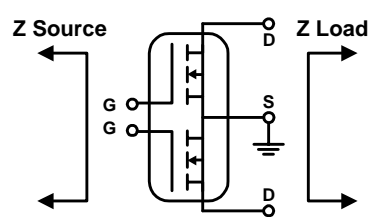

Frequency MHz	Z Source $\Omega$		Z Load $\Omega$	
	R	jX	R	jX
445	1.1	-3.3	5.5	2.3
470	1.2	-3.8	6.0	3.5
560	2.1	-6.3	5.4	3.7
660	4.0	-10.1	4.3	3.0
760	7.0	-5.8	3.5	0.4
860	3.9	-2.0	2.8	-1.4
885	1.3	-1.7	3.7	-1.0

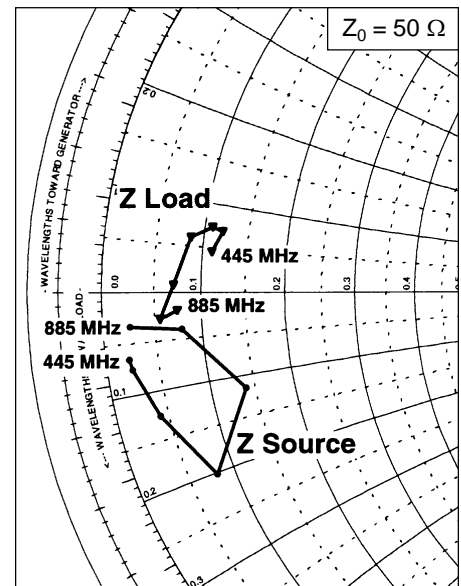

**Typical Scattering Parameters (one side)**

( $V_{DS} = 28\text{ V}$ ,  $I_D = 4\text{ A}$ )

f (MHz)	S11		S21		S12		S22	
	Mag	Ang	Mag	Ang	Mag	Ang	Mag	Ang
400	0.966	179	1.56	14	0.003	-46.5	0.919	-165
410	0.965	178	1.54	12.7	0.003	-47.5	0.922	-165
420	0.964	178	1.51	11.5	0.003	-49.2	0.925	-165
430	0.964	178	1.49	10.3	0.003	-50.4	0.929	-166
440	0.963	178	1.46	9	0.003	-50.8	0.933	-166
450	0.962	178	1.45	7.7	0.003	-49.9	0.937	-166
460	0.961	177	1.43	6.6	0.003	-51.7	0.941	-166
470	0.958	177	1.42	5.4	0.003	-50.9	0.944	-167
480	0.956	177	1.41	4.3	0.003	-51.4	0.946	-167
490	0.955	177	1.41	3.1	0.003	-52.8	0.948	-167
500	0.953	176	1.41	1.8	0.003	-54.9	0.951	-167
510	0.951	176	1.41	0.5	0.003	-53.1	0.955	-167
520	0.949	176	1.42	-1	0.003	-56.5	0.957	-167
530	0.947	176	1.43	-2.6	0.003	-55.8	0.959	-168
540	0.944	175	1.44	-4.2	0.003	-53.3	0.961	-168
550	0.942	175	1.46	-6	0.003	-57.1	0.963	-168
560	0.936	175	1.48	-8	0.003	-58.2	0.966	-168
570	0.931	174	1.50	-10	0.003	-59.6	0.967	-169
580	0.926	174	1.52	-12.2	0.003	-61.1	0.969	-169
590	0.918	174	1.55	-14.4	0.003	-64.9	0.973	-169
600	0.911	174	1.59	-16.7	0.003	-67.7	0.977	-169
610	0.904	173	1.63	-19.3	0.003	-74.1	0.98	-169
620	0.893	173	1.68	-22.2	0.003	-74	0.985	-170
630	0.882	173	1.74	-25.6	0.003	-78.8	0.986	-170
640	0.869	173	1.81	-29.4	0.003	-83.7	0.991	-170
650	0.854	173	1.88	-33.9	0.003	-87.4	0.993	-171
660	0.836	173	1.95	-38.9	0.004	-94.1	0.996	-171
670	0.817	173	2.02	-44.5	0.004	-101	0.997	-171
680	0.798	174	2.08	-51	0.004	-109	0.998	-172
690	0.781	175	2.12	-58.1	0.004	-116	0.998	-172
700	0.768	177	2.14	-66.1	0.004	-125	0.998	-173
710	0.764	179	2.11	-74.3	0.004	-135	0.995	-173
720	0.769	-179	2.05	-82.6	0.004	-146	0.991	-174
730	0.783	-177	1.95	-90.6	0.004	-156	0.986	-174
740	0.804	-175	1.83	-98.2	0.004	-165	0.98	-174
750	0.828	-175	1.69	-105	0.004	-173	0.975	-174
760	0.851	-174	1.55	-112	0.004	175	0.97	-174
770	0.871	-174	1.41	-117	0.004	169	0.967	-174
780	0.889	-174	1.29	-122	0.003	160	0.964	-174
790	0.906	-175	1.17	-127	0.003	155	0.963	-174
800	0.919	-175	1.06	-131	0.003	147	0.96	-174
810	0.93	-176	0.966	-134	0.003	142	0.96	-174
820	0.94	-176	0.88	-137	0.003	138	0.959	-174
830	0.948	-177	0.804	-140	0.003	135	0.958	-174
840	0.953	-177	0.734	-143	0.003	130	0.958	-174
850	0.96	-177	0.672	-145	0.003	127	0.958	-174
860	0.963	-178	0.616	-147	0.003	123	0.958	-174
870	0.966	-178	0.566	-148	0.003	120	0.958	-174
880	0.97	-179	0.523	-150	0.003	121	0.96	-174
890	0.972	-179	0.485	-151	0.003	116	0.961	-174
900	0.973	-179	0.452	-152	0.003	118	0.962	-174
910	0.976	-180	0.421	-154	0.003	114	0.962	-175
920	0.978	-180	0.394	-155	0.003	110	0.963	-175
930	0.979	180	0.368	-156	0.003	108	0.961	-175
940	0.982	180	0.346	-157	0.003	108	0.962	-175
950	0.983	179	0.325	-158	0.003	106	0.962	-175
960	0.983	179	0.305	-159	0.003	107	0.961	-175
970	0.985	179	0.287	-160	0.003	105	0.963	-175
980	0.985	179	0.269	-161	0.003	106	0.964	-175
990	0.984	178	0.254	-162	0.003	107	0.964	-175
1000	0.987	178	0.239	-162	0.003	105	0.965	-175

**Test Circuit**

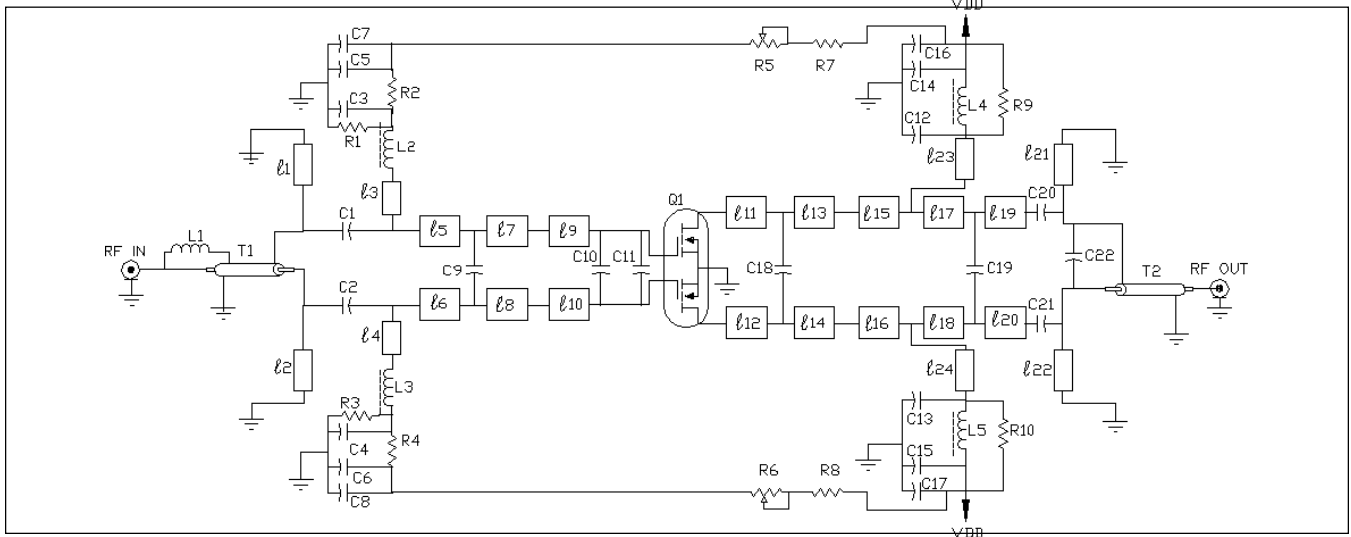

Block diagram for  $f = 470\text{--}860$  MHz broadband circuit

Q1	PTF 10159				
L1	1 Turn, #22 AWG, 0.12" I.D.				
L2, L3	10 nH	SMT Coil			
L4, L5	4x8 mm	Ferrite Bead			
l1, l2, l21, l22	$0.25 \lambda$ 680 MHz	Microstrip 25 $\Omega$			
l3, l4	$0.065 \lambda$ 800 MHz	Microstrip 70 $\Omega$			
l5, l6	$0.010 \lambda$ 800 MHz	Microstrip 18.5 $\Omega$			
l7, l8	$0.07 \lambda$ 800 MHz	Microstrip 18.5 $\Omega$			
l9, l10	$0.060 \lambda$ 800 MHz	Microstrip 10.2 $\Omega$			
l11, l12	$0.0525 \lambda$ 800 MHz	Microstrip 8.1 $\Omega$			
l13, l14	$0.061 \lambda$ 800 MHz	Microstrip 9.3 $\Omega$			
l15, l16	$0.032 \lambda$ 800 MHz	Microstrip 12.13 $\Omega$			
l17, l18	$0.021 \lambda$ 800 MHz	Microstrip 22.6 $\Omega$			
l19, l20	$0.01 \lambda$ 800 MHz	Microstrip 22.6 $\Omega$			
l23, l24	$0.25 \lambda$ 680 MHz	Microstrip 60 $\Omega$			
C1, C2, C20, C21	51 pF	Chip Cap ATC 100 B			
C3, C4, C12, C13	91 pF	Chip Cap ATC 100 B			
C5, C6, C14, C15	0.1 $\mu$ F	SMT K1206			
C7, C8, C16, C17	10 $\mu$ F	Electrolytic Capacitor			
C9	11 pF	Chip Cap ATC 100 B			
C10, C22	0.6–6.0 pF	Variable Capacitor, Johanson Trimmer			
C11	4.7 pF	Chip Cap ATC 100 A			
C18	13.0 pF	Chip Cap ATC 100 B			
C19	3.6 pF	Chip Cap ATC 100 B			
R1, R3	200 $\Omega$	1/8 W K 1206 SMT Resistor			
R2, R4	200 $\Omega$	1/8 W K 1206 SMT Resistor			
R5, R6	1 K $\Omega$	1/4 W Potentiometer			
R7, R8	500 $\Omega$	1/4 W Resistor			
R9, R10	1.8 $\Omega$	1/4 W Resistor			
T1, T2	UT-85-25 Balun Coaxial				
Circuit Board	0.028" G200, $\epsilon_r = 4.55$ @ 1 MHz, 2 oz. Copper, AlliedSignal				

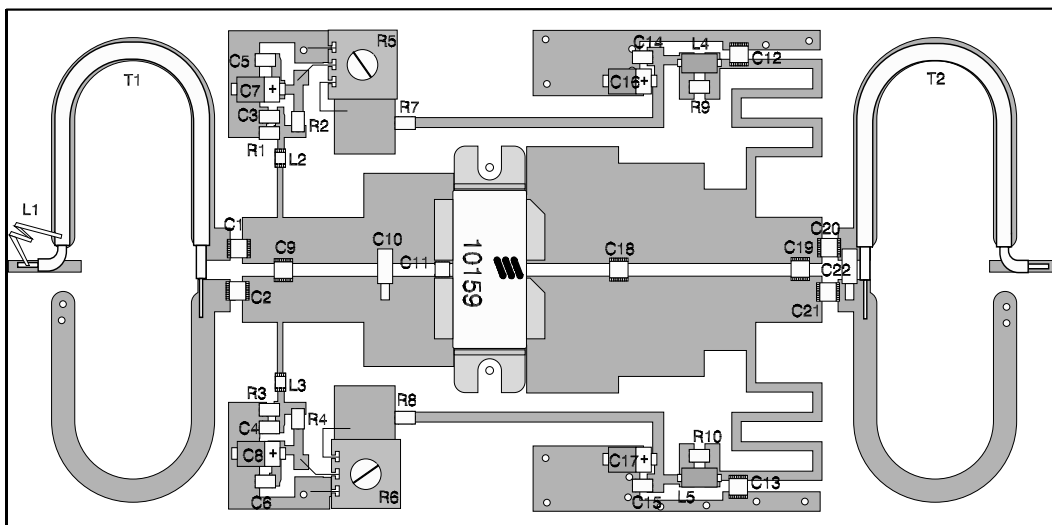

Components layout (not to scale)



Test circuit artwork (1 inch )