

973075

DISTINCTIVE CHARACTERISTICS

- Monolithic three-channel video DAC with color look-up table
- 64 x 13 color map
- 83 MHz maximum pixel data rate
- On-chip Address Multiplexer supports system addressing and graphics pixel data addressing
- Compatible with both 8- and 16-bit systems
- Overlay, blank, and composite sync capabilities
- Connects directly to 50- or 75-Ω monitors
- TTL-compatible inputs

GENERAL DESCRIPTION

The Am8159 Three-Gun Graphics Color Palette provides a color look-up table and three video DACs on a single chip for use in medium-resolution graphics systems. The palette contains all the necessary logic for sync, blank, and text overlay.

A 64 x 13 RAM acts as a look-up table and supplies color information to be decoded for the three 4-bit DACs. Blink capability is supported by the thirteenth bit in the RAM and a Blink clock input. The Am8159 provides Red, Green, and Blue outputs and allows simultaneous display of 64 colors from a palette of 4096.

An on-chip Address Multiplexer selects either the Video Address pins for the graphics mode, or the System Address pins for loading into or reading from the look-up table. Reading from and writing to the table is handled by two control pins, S₀ and S₁, and thirteen TTL bus-compatible bidirectional Color Data pins.

The video DACs are RS-343-compatible with sync on the Green channel, and connect directly to 50- or 75-Ω monitors.

BLOCK DIAGRAM

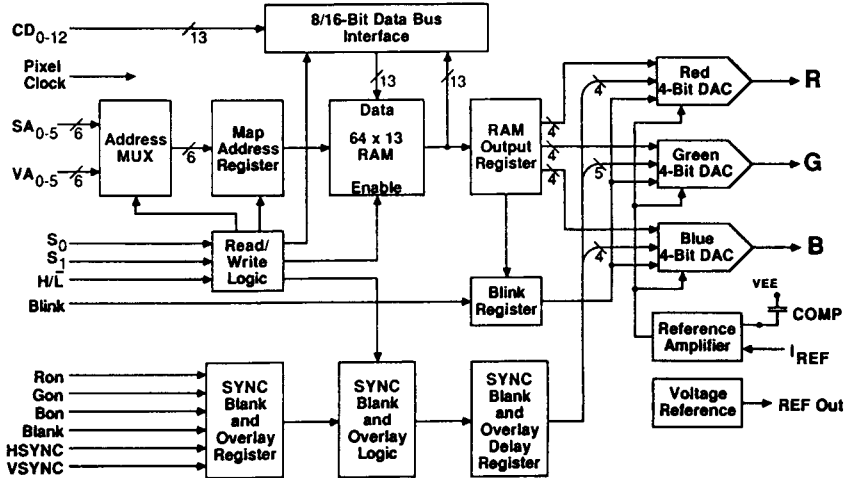

BD006170

S-3

Orig

001150

T 1150

AMD

CONNECTION DIAGRAMS Top View

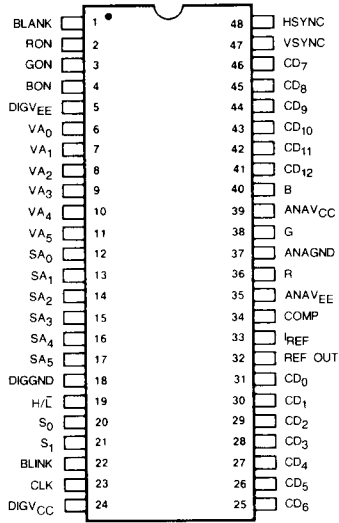

CD009080

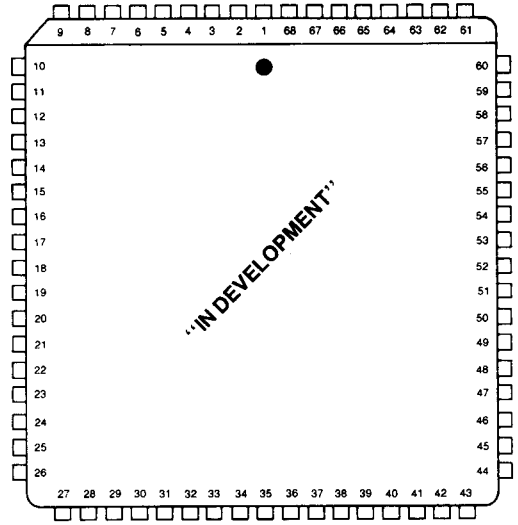

CD009960

Note: Pin 1 is marked for orientation.

LOGIC SYMBOL

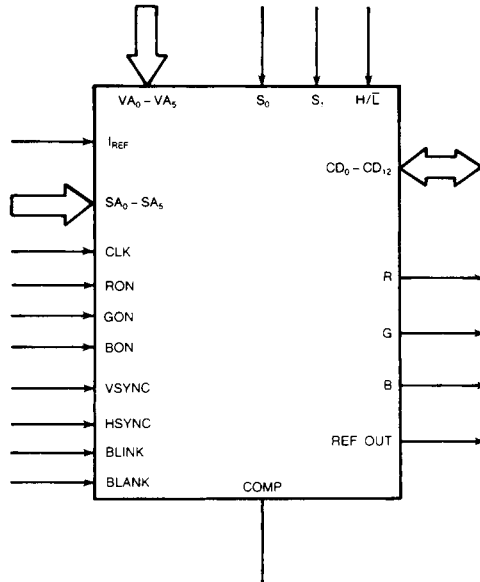

LS002070

ORDERING INFORMATION

Standard Products

AMD products are available in several packages and operating ranges. The order number (Valid Combination) is formed by a combination of:

- A. Device Number**
- B. Speed Option** (if applicable)
- C. Package Type**
- D. Temperature Range**
- E. Optional Processing**

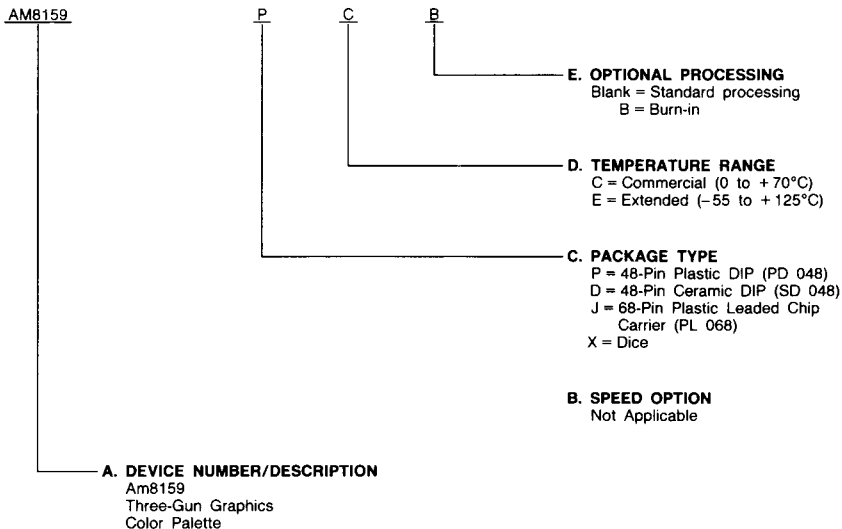

Valid Combinations

Valid Combinations	
AM8159	PC, PCB, DC, DCB, DE, DEB, JC, XC

Valid Combinations list configurations planned to be supported in volume for this device. Consult the local AMD sales office to confirm availability of specific valid combinations, to check on newly released valid combinations, and to obtain additional data on AMD's standard military grade products.

PIN DESCRIPTION

CD₀ - CD₁₂ Color Data (I/O, TTL, Three-State)

Color Data pins are used to write into or read back color information from the color map. The data is composed of four fields: three 4-bit, and one single-bit field. Data from each of the 4-bit fields is decoded and sent to the video DACs. The MSBs are CD₃, CD₇, and CD₁₁ for the Red, Green, and Blue DACs, respectively. The single-bit field, CD₁₂, is the Blink Attribute bit. A value of 1 on CD₁₂, along with the BLINK input being HIGH, results in the Color Data being inverted. The color data bits are assigned as shown:

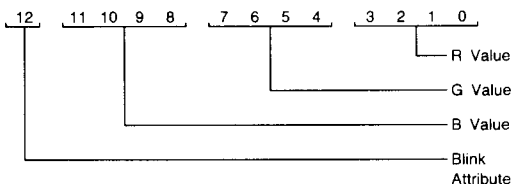

S₀, S₁ State Control (Inputs, TTL)

These pins control the operational state of the Am8159. S₁ enables the part for read/write functions and selects which set of address pins is active. S₀ controls the direction of the Color Data pins and is used for text overlay.

H/ \bar{L} High/Low Byte Control (Input, TTL)

The Am8159 supports both 8- and 16-bit systems. In 8-bit systems, this input maps the high-order color data bits onto the low-order data pins. With H/ \bar{L} LOW, the eight low-order bits are on pins CD₀ - CD₇. With H/ \bar{L} HIGH, the five high-order bits are mapped onto pins CD₀ - CD₄. With H/ \bar{L} HIGH, pins CD₅ - CD₇ are driven LOW during read operations, and ignored while writing. While writing in 8-bit systems, the eight low-order bits must be written before the five high-order bits. In 16-bit systems, H/ \bar{L} should be tied LOW. Note that the table below is used for both Update and Readback operations.

H/ \bar{L} = 0	RAM Data	12	11	10	9	8	7	6	5	4	3	2	1	0
	CD Pins	12	11	10	9	8	7	6	5	4	3	2	1	0
H/ \bar{L} = 1	RAM Data	12	11	10	9	8								
	CD Pins	4	3	2	1	0								

VA₀ - VA₅ Video Address (Input, TTL)

VA₀ - VA₅ are the registered Video Address inputs for the color map in the Display mode. These pins are selected when S₁ is HIGH.

SA₀ - SA₅ System Address (Input, TTL)

SA₀ - SA₅ pins are the non-registered System Address inputs for the color map during Update and Readback operations. They may be directly connected to the System Address bus, and are selected when S₁ is LOW.

CLK Clock (Input, TTL)

CLK is the pixel clock input which is used for all internal timing.

RON Red On (Input, TTL)

GON Green On (Input, TTL)

BON Blue On (Input, TTL)

These pins control the level of the Red, Green, and Blue outputs in the Overlay mode. When HIGH, the appropriate video DAC is driven to peak white (10% overbright). When LOW, the output is forced to reference black. These pins

enable the user to overlay text onto graphics in up to eight colors.

VSYNC Vertical Sync (Input, TTL)

HSYNC Horizontal Sync (Input, TTL)

The sync pins are internally XORed and connected to the DACs to generate a composite sync signal. Sync inputs override all other inputs and drive the Green output to 40 IRE units (286 mV) below the blanking level, and the Red and Blue outputs to the blanking level. When HSYNC and VSYNC are both active (HIGH), all outputs are driven to the blank level.

BLANK Blank (Input, TTL)

BLANK input is connected to the DAC Decoders to blank the screen during retrace intervals. A HIGH BLANK signal overrides the color data and overlay information and drives all DAC outputs to 10 IRE units (71 mV) below the reference black level.

BLINK Blink (Input, TTL)

This input controls the blinking of the video outputs. When BLINK and the displayed color's Blink Attribute bit, CD₁₂, are both active (HIGH), the color data bits will be inverted.

R Red Output (Output, Analog)

G Green Output (Output, Analog)

B Blue Output (Output, Analog)

R, G, and B are the three video DAC outputs, one for each color gun. These outputs will directly drive 50- or 75- Ω monitor inputs. 75- Ω lines may be doubly terminated with a 75- Ω resistor at the monitor and another 75- Ω resistor at the device output pin. The output voltages may range from ground to -1.4 V or from +1.4 V to ground.

REF OUT Reference Output (Output, Analog)

REF OUT is the output from the on-chip precision Voltage Reference. Typical output value is 2.286 V.

I_{REF} Reference Input (Input, Analog)

I_{REF} is the reference current input for the DACs. A reference resistor is connected from REF OUT to I_{REF} in order to set the full-scale output current of the DACs. A 1-k Ω resistor will result in a 1.071-V peak video signal across a doubly terminated 75- Ω line. Other full-scale currents can be found by the relationship:

$$I_{FS} = \frac{2.286 \text{ V}}{R_{REF}}$$

Typical R_{REF} values are shown in the following table.

Load Resistance (Ω)	Full-Scale Current (mA)	R _{REF} (k Ω)	Nearest 5% Standard Value (k Ω)
100.0	10.71	2.67	2.7
75.0	14.28	2.00	2.0
50.0	21.42	1.33	1.3
37.5	28.56	1.00	1.0

COMP Reference Compensation

A compensation capacitor for the Reference Amplifier must be connected to this pin. The suggested value is a 0.1 μ F paralleled by a 100-pF capacitor to the ANAV_{EE} pin.

DIGV_{CC} Digital Positive Power Supply

Digital, TTL, +5-V power supply.

ANAV_{CC} Analog Positive Power Supply

Analog +5-V power supply for the Voltage Reference and Reference Amplifier.

DIGV_{EE} Digital Negative Power Supply

Digital, ECL, -5.0-V or -5.2-V power supply.

ANAVEE Analog Negative Power Supply

Analog -5.0-V or -5.2-V power supply for the DACs and Reference Amplifier.

DIGGND Digital Ground

Ground for the digital portions of the chip.

ANAGND Analog Ground

Ground for the analog portions of the chip.

FUNCTIONAL DESCRIPTION

The Am8159 Three-Gun Graphics Color Palette has four modes of operation as selected by the State Control pins. These modes are Display, Overlay, Update, and Readback.

TABLE 1. MODES OF OPERATION

Inputs		Description	
S ₁	S ₀	Operational Mode	Active Address
0	0	Update (Write)	SA ₀ - SA ₅
0	1	Readback (Read)	SA ₀ - SA ₅
1	0	Overlay	N.A.
1	1	Display (Run)	VA ₀ - VA ₅

In Display or Overlay modes, the Am8159 has three levels of pipeline to allow a high pixel rate and ease system timing requirements. Address and associated sync, blank, and overlay information are latched into registers on one CLK rising edge, with the corresponding video information exiting three CLK cycles later.

In Update and Readback modes, the color look-up table may be loaded, and the stored information read back and verified.

Address Multiplexer and Decoder

The on-chip Address Multiplexer allows interfacing with both the System Address, as well as the Video Address bus. With S₁ HIGH, data on the Video Address pins (VA₀ - VA₅) is latched in the Map Address Register on the first rising edge of CLK . The Map Address Registers drive the RAM Decoders and select one of the 64 13-bit words stored in the color map. In Update or Readback mode S₁ LOW, System Address pins (SA₀ - SA₅) are active and the Map Address Registers are transparent.

Color Map and Registers

The color map consists of a 64 x 13 RAM, and is organized as 64 13-bit words. Each word is made up of four fields: three 4-bit fields for each of the decoders (Red, Green, and Blue), and one single-bit field for the Blink Attribute bit. In the Display and Overlay modes, color data from the RAM is latched into the RAM Output Registers on the second rising edge of the CLK . In Readback mode, RAM Output Registers are transparent, and outputs of the RAM connect to the Color Data pins (CD₀ - CD₁₂).

Sync, Blank, and Overlay

To ease system timing, HSYNC, VSYNC, BLANK, S₀, S₁, RON, GON, and BON signals are delayed the same number of CLK cycles as the corresponding video address. In the Overlay mode, the RON, GON, and BON pins are used to override the color data in the RAM, forcing the DAC outputs to peak white when HIGH, or reference black when LOW. Peak white is 10% brighter than reference white, such that light colored text may still be visible over a light background. The RON, GON, and BON pins allow text to be displayed over

graphics in eight colors. The BLANK signal overrides all color and overlay information and forces all video outputs to a blank level of 10 IRE units (71 mV) below reference black. The HSYNC and VSYNC inputs are internally XORed to create a composite sync signal. A HIGH composite sync signal overrides all color, overlay and blank signals, and forces the Green DAC to a sync level of 40 IRE units (286 mV) below blank. The Red and Blue DACs are forced to the blank level. When HSYNC and VSYNC are both active (HIGH), all video outputs are at the blank level.

DAC Decoder and DAC

Each of the DAC decoders (Red, Green, and Blue) receives one 4-bit word from the color data registers. Additionally, the Blink Attribute bit is ANDed with the Blink clock signal. When the result is active (HIGH), the 4-bit word from the color data registers is inverted in each of the decoders. The 4-bit word is fully decoded to drive fifteen gray-scale current switches. The DACs are fully decoded to ensure that all color transitions consist purely of current switches turning either off or on. This architecture leads to a DAC with less glitch energy than a standard R-2R construction, where transitions commonly have current switches turning off while others are turning on simultaneously. Additional input signals come from the Sync, Blank, and Overlay output registers. These signals override the color data information to switch the gray-scale as well as the larger current sources needed to force the DACs to the appropriate sync or blank output levels. All decoded signals are registered before driving the DAC switches to minimize timing skew that would result in the glitching of the output waveform. The Red and Blue DACs consist of fifteen gray-scale current sources, as well as current sources for 10% overbright and blanking. The Green DAC is similar, with the addition of a current source switch for sync level capabilities.

Voltage Reference

An on-chip precision Voltage Reference is included for setting the full-scale output current. A reference current is generated by placing a reference resistor between the REF OUT and I_{REF} pins. The relationship between the reference resistor and the full-scale current is:

$$I_{FS} = \frac{28.56 \text{ V}}{R_{REF}}$$

The Voltage Reference output has a typical value of 2.286 V.

Color Data Input/Output

The Am8159 supports both 8- and 16-bit systems. The Color Data pins are bidirectional and TTL bus-compatible where CD₁₂ is the MSB. In 8-bit systems the H/L input maps the high-order color data bits onto the low-order data pins. With H/L LOW, the eight low-order bits are placed on pins CD₀ - CD₇ . With H/L HIGH, the five high-order bits are mapped onto pins CD₀ - CD₄ . When H/L is HIGH, pins CD₅ - CD₇ are driven LOW during a Readback, and are ignored while writing. In 8-bit systems the eight low-order bits must be written into the RAM before the five high-order bits. In 16-bit systems, H/L should be tied LOW.

TABLE 2. FUNCTION TABLE

Inputs										Outputs		Description
R, G, BON	S ₁	S ₀	BLANK	HSYNC	VSYNC	BLINK	CD ₁₂	Color Data	Current	Voltage into 37.5 Ω		
H	H	L	L	L	L	X	X	X	0 mA	0 mV	Peak White	
X	H	H	L	L	L	L	X	15	1.892 mA	-71 mV	Reference White	
X	H	H	L	L	L	X	L	15	1.892 mA	-71 mV	Reference White	
.	15 Equal Steps	
X	H	H	L	L	L	X	L	0	19.040 mA	-714 mV	Reference Black	
X	H	H	L	L	L	L	X	0	19.040 mA	-714 mV	Reference Black	
X	H	H	L	L	L	H	H	0	1.892 mA	-71 mV	Reference White	
.	15 Equal Inverse Steps	
X	H	H	L	L	L	H	H	15	19.040 mA	-714 mV	Reference Black	
L	H	L	L	L	L	X	X	X	19.040 mA	-714 mV	Reference Black	
X	X	X	H	L	L	X	X	X	20.932 mA	-785 mV	Blanking	
X	X	X	X	H	H	X	X	X	20.932 mA	-785 mV	Blanking	
X	X	X	X	H	L	X	X	X	28.560 mA	-1071 mV	Composite Sync*	
X	X	X	X	L	H	X	X	X	28.560 mA	-1071 mV	Composite Sync*	

H = HIGH L = LOW X = Don't Care

*Green Only. Red and Blue are at Blanking Level.

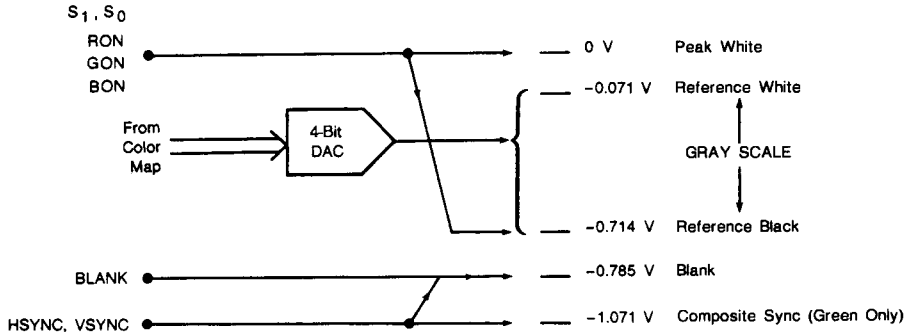

AF003662

Figure 1. Am8159 DAC Output Levels

APPLICATIONS

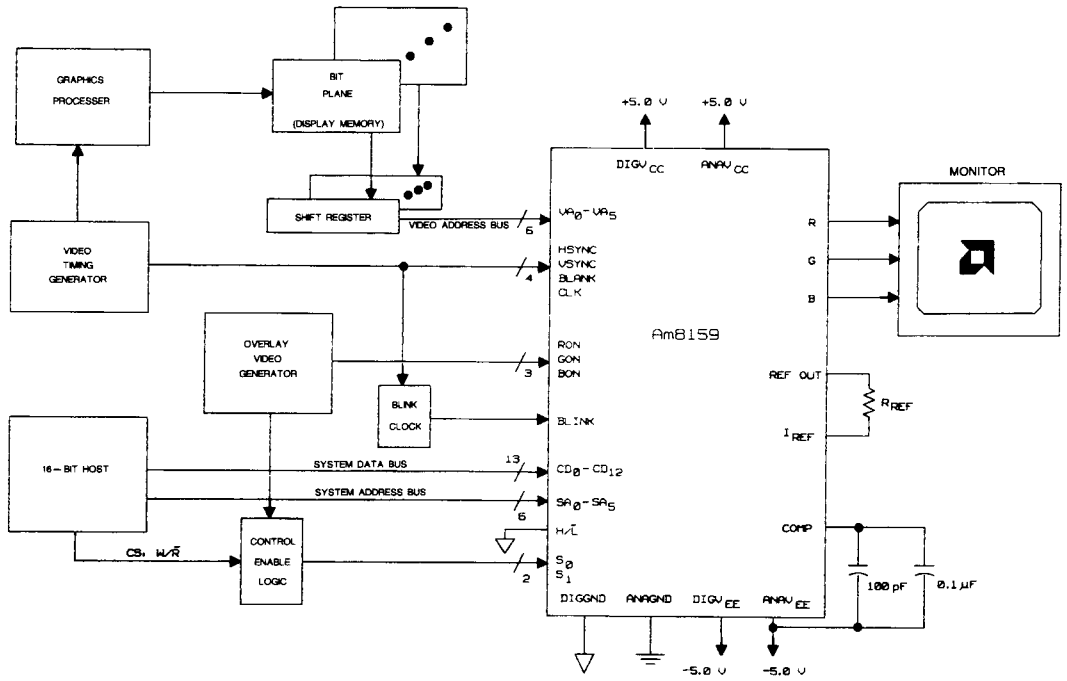

AF004121

Figure 2. Typical Application Diagram

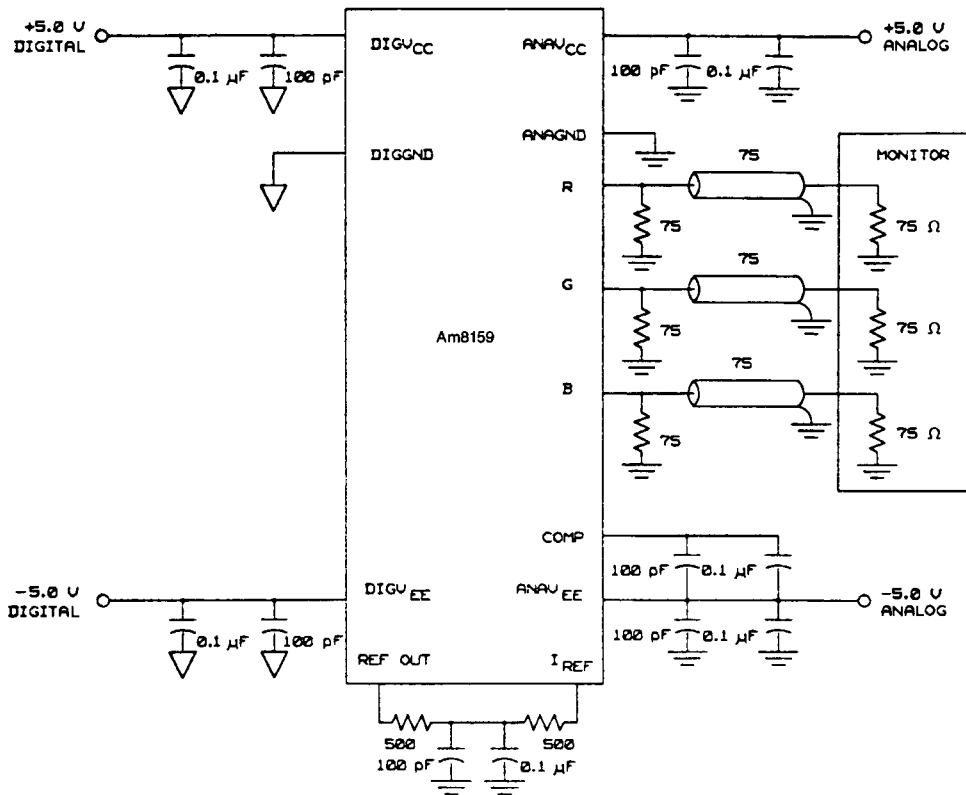

CD009101

Figure 3. Typical Connection Diagram

Key:

 = Digital Ground

 = Analog Ground

TB000210

ABSOLUTE MAXIMUM RATINGS

Storage Temperature	-65 to +150°C
Ambient Temperature Under Bias	-55 to +125°C
Positive Supply Voltage	-0.7 to +7.0 V
Negative Supply Voltage	+0.7 to -7.0 V
DC Input Voltage (TTL)	-0.5 to +7.0 V
DC Input Current (TTL)	-30 to +5.0 mA

Stresses above those listed under ABSOLUTE MAXIMUM RATINGS may cause permanent device failure. Functionality at or above these limits is not implied. Exposure to absolute maximum ratings for extended periods may affect device reliability.

OPERATING RANGES

Commercial (C) Devices	
Temperature (T _A)	0 to +70°C
Positive Supply Voltages	
Digital (DIGV _{CC}) and Analog (ANAV _{CC}) ...	+5 V ±5%
Negative Supply Voltages	
Digital (DIGV _{EE}) and Analog (ANAV _{EE}) ...	-5 V +5%, -5 V -9.2%

Extended Commercial (E) Devices	
Temperature (T _C)	-55 to +125°C
Positive Supply Voltages	
Digital (DIGV _{CC}) and Analog (ANAV _{CC})	(to come)
Negative Supply Voltages	
Digital (DIGV _{EE}) and Analog (ANAV _{EE})	(to come)

Operating ranges define those limits between which the functionality of the device is guaranteed.

DC CHARACTERISTICS over Commercial Operating Range unless otherwise specified

Parameter Symbol	Parameter Description	Test Conditions (Note 1)	Min.	Typ. (Note 3)	Max.	Units
V _{IH}	Input HIGH level	Guaranteed Input Logical HIGH Voltage for All Inputs (Note 2)	2.0			Volts
V _{IL}	Input LOW Level	Guaranteed Input Logical LOW Voltage for All Inputs (Note 2)			0.8	Volts
V _I	Input Clamp Voltage	V _{CC} = Min., I _{IN} = -18 mA			-1.2	Volts
I _{IL}	Input LOW Current	V _{CC} = Max., V _{IN} = 0.4 V			-0.4	mA
I _{IH}	Input HIGH Current	V _{CC} = Max., V _{IN} = 2.7 V			40	μA
I _I	Input HIGH Current	V _{IN} = V _{CC} = 5.25 V			0.1	mA
V _{OH}	Output HIGH Voltage	V _{CC} = Min., V _{IN} = V _{IH} or V _{IL} I _{OH} = -400 μA	2.4			Volts
V _{OL}	Output LOW Voltage	V _{CC} = Min., V _{IN} = V _{IH} or V _{IL} I _{OL} = 8 mA			0.5	Volts
I _{SC}	Output Short-Circuit Current (Note 4)	V _{CC} = Max.	10		50	mA
DIG _I CC	Power Supply Current	DIGV _{CC} = Max.		45	70	mA
ANA _I CC	Power Supply Current	ANAV _{CC} = Max.		5	12.5	mA
DIG _I EE	Power Supply Current	DIGV _{EE} = Max.		180	300 ¹	mA
ANA _I EE	Power Supply Current (Note 7)	ANAV _{EE} = Max.		75	100	mA

Notes: See notes following Reference Voltage Specifications table.

DAC SPECIFICATIONS over Commercial Operating Range unless otherwise specified

Parameter Symbol	Parameter Description	Test Conditions (Notes 1 & 5)	Min.	Typ.	Max.	Units
	Resolution	Gray Scale	4	4	4	Bits
	Nonlinearity	Gray Scale			±0.125	LSB
	Differential Nonlinearity	Gray Scale (Note 6)			±0.125	LSB
V _{OC}	Output Voltage Compliance			±1.4		Volts
I _{ZS}	Zero-Scale Current				10	μA
I _{MAX}	Maximum Output Current				28.56	mA
	Full-Scale Tracking				3	% Gray Scale
	Full-Scale Tempco			50		ppm/°C
PSSI	Power Supply Sensitivity	(Note 6)			0.4	% Gray Scale
I _{REF}	Reference Current				2.3	mA
C _{OUT}	Output Capacitance	(Note 6)		10		pF
	Glitch Energy	(Note 6)		50		pV-sec
t _R	Rise Time: 10 to 90%	(Note 8)				ns
t _F	Fall Time: 90 to 10%	(Note 8)				ns
t _S	Settling Time	±0.5 LSB (Note 6)		5		ns
f _{CLK}	Clock Frequency	(Note 8)	DC		83	MHz

Notes: See notes following Reference Voltage Specifications table.

REFERENCE VOLTAGE SPECIFICATIONS over Commercial Operating Range unless otherwise specified

Parameter Symbol	Parameter Description	Test Conditions (Note 1)	Min.	Typ.	Max.	Units
V _{REF}	Reference Voltage	I _{REF} = 1 to 2.3 mA	2.263	2.286	2.309	Volts
	Line Regulation				0.4	%V _{REF}
	Reference Voltage Tempco	T _A = 0 to +70°C (Note 6)		50		ppm/°C

- Notes*:
- For conditions shown as Min. or Max., use the appropriate values specified under recommended operating ranges.
 - V_{IH}, V_{IL} are tested for each input at least once. Thereafter, hard HIGH and LOW levels are used for all other tests.
 - All typical values are at V_{CC} = 5.0 V, V_{EE} = -5.0 V, and T_A = 25°C. The device may be operated with a V_{EE} of -5.2 V with no effect on performance.
 - Not more than one output should be shorted at a time. Duration of short not to exceed one second.
 - Gray Scale is defined as output levels between reference white and reference black. DAC nonlinearity and differential nonlinearity are measured at a frequency less than or equal to 10 MHz in production over operating temperature range at nominal supply voltages. DAC output terminated into 37.5-Ω load, with a full scale current of 28.56 mA.
 - This typical value is provided for design reference and will not be tested in production.
 - Power supply currents include load current through a 37.5-Ω load to ground on all three outputs. Reference equals 1.0 kΩ.
 - Not all tests are being performed in manufacturing. Tests are guaranteed by engineering characterization with periodic manufacturing sampling.

*Notes listed correspond to respective references made in DC Characteristics, DAC Specifications, and Reference Voltage Specification tables.

Explanation of DAC Specifications

Resolution

Resolution refers to the number of discrete steps or levels which the DAC can provide, and is expressed as a number of bits. A DAC having n bits of resolution provides 2^n discrete analog steps. Each of these analog steps is referred to as a least significant bit, or LSB.

Nonlinearity

Nonlinearity is the maximum deviation of an actual DAC output from an ideal output defined by a straight line drawn through the end points of the transfer function. A DAC must be linear to within $1/2$ a step to be accurate to its full resolution.

Differential Nonlinearity

Differential Nonlinearity (DNL), is the maximum deviation of any actual output step from an ideal step size. If the DNL is specified as $1/2$ LSB, or step, the step size from one step to the next may be from $1/2$ to $3/2$ of an ideal step.

Output Voltage Compliance

The Output Voltage Compliance is that voltage which may be impressed on the output current pins without degrading the specified accuracy of the DACs.

Zero-Scale Current

Zero-Scale Current is the current produced at the peak white output level.

Maximum Output Current

The Maximum Output Current is the maximum current at the sync level that the outputs may operate at without degrading the specified accuracy of the DACs.

Full-Scale Tracking

The Full-Scale Tracking is the maximum deviation in output current levels between the three DAC outputs when all DACs are at Reference Black.

Full-Scale Tempco

The Full-Scale Temperature Coefficient (Tempco) is the effect of temperature change, within the operating range, on the DAC output current. This is specified as the change in current per degree centigrade.

Power Supply Sensitivity

The effect of a power supply voltage change on the DAC current output is referred to as power supply sensitivity (PSSI). For the Am8159 the PSSI is expressed as a percentage change in any output current level while the supply voltage

varies over the recommended operating range. This specification assumes the internal voltage reference is used.

Reference Current

Reference Current is the range of acceptable reference current at the IREF pin.

Output Capacitance

Output Capacitance is the capacitance seen at any of the DAC output pins.

Glitch Energy

Glitch Energy is the product of voltage and time for any transient ringing around a final DAC transition output level.

Rise Time, Fall Time

The Rise or Fall Time is the time that any DAC transition takes to change from 10 to 90, or 90 to 10 percent of the transition voltage.

Settling Time

Settling Time is the time from when the output first changes until the output remains within a certain error band around the final output voltage level.

Clock Frequency

The Clock Frequency is that range of clock frequencies for which the device outputs remain 4-bit accurate.

Explanation of Reference Voltage Specifications

Reference Voltage

The Reference Voltage is the output voltage provided by the reference voltage source.

Line Regulation

The effect of a change in supply voltage on the reference voltage output is the Line Regulation. For the Am8159 this is given as a percent change of the reference voltage caused by supply voltage changes within the operating range.

Load Regulation

The change in the reference voltage caused by a change in the current sourced by the reference current output is the Load Regulation. For the Am8159 this is given as a percent change in reference voltage for changes in current as specified.

Reference Voltage Temperature Coefficient

The Reference Voltage Temperature Coefficient is the effect of temperature change on the reference voltage. This is shown as the change in voltage per degree centigrade.

KEY TO SWITCHING WAVEFORMS

WAVEFORM	INPUTS	OUTPUTS
	MUST BE STEADY	WILL BE STEADY
	MAY CHANGE FROM H TO L	WILL BE CHANGING FROM H TO L
	MAY CHANGE FROM L TO H	WILL BE CHANGING FROM L TO H
	DON'T CARE: ANY CHANGE PERMITTED	CHANGING: STATE UNKNOWN
	DOES NOT APPLY	CENTER LINE IS HIGH IMPEDANCE "OFF" STATE

KS000010

SWITCHING TEST CIRCUIT

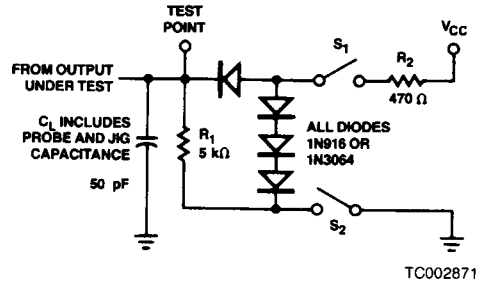

TC002871

SWITCHING CHARACTERISTICS over operating range unless otherwise specified

No.	Parameter Symbol	Parameter Description	Min.	Typ.	Max.	Units
1	t_{CLK}	Clock Period (Note 8)	12			ns
2	t_S	$VA_0 - VA_5$, S_0 , RON, GON, BON, HSYNC, VSYNC, BLANK Setup Before CLK \uparrow (Note 8)	5			ns
3	t_H	$VA_0 - VA_5$, S_0 , RON, GON, BON, HSYNC, VSYNC, BLANK Hold After CLK \uparrow (Note 8)	2			ns
4	t_{PD}	CLK \uparrow to 10% R, G, B Change			12	ns
5	Δt_{PD}	Skew in CLK \uparrow to 10% Change Between R, G, and B Outputs (Note 8)			1.2	ns
6	t_S	S_0 Setup Before $S_1 \downarrow$	0			ns
7	t_S	H/ \bar{L} Setup Before $S_1 \downarrow$	0			ns
8	t_{PD}	$S_1 \downarrow$ to Data Active	10			ns
9	t_{PD}	$S_1 \downarrow$ to Data Valid			30	ns
10	t_{PD}	Address Change to Data Change	10		30	ns
11	t_{PD}	H/ \bar{L} Change to Data Change	10		30	ns
12	t_H	S_0 Hold After $S_1 \uparrow$ (Note 8)	5			ns
13	t_{PD}	$S_1 \uparrow$ to High Z			30	ns
14	t_W	Write Pulse Width	70			ns
15	t_S	Address Setup Before $S_1 \downarrow$	0			ns
16	t_H	Address Hold After $S_1 \uparrow$ (Note 8)	5			ns
17	t_H	H/ \bar{L} Hold After $S_1 \uparrow$	5			ns
18	t_S	Data Setup Before $S_1 \uparrow$	30			ns
19	t_H	Data Hold After $S_1 \uparrow$	7			ns

Notes: See notes following Reference Voltage Specifications table.

SWITCHING WAVEFORMS

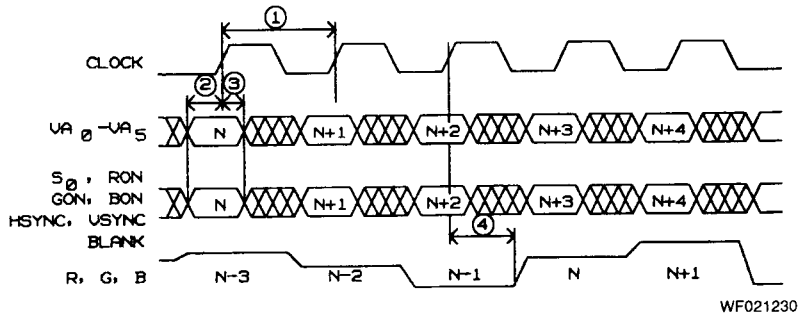

Run and Overlay Timing

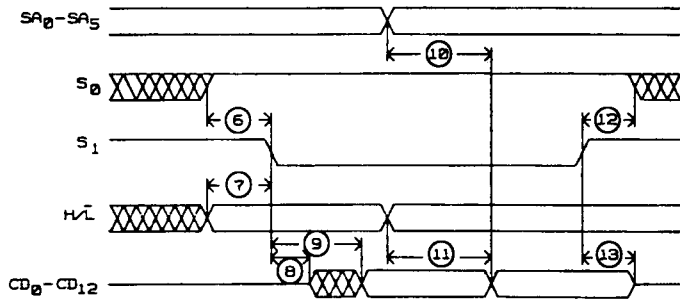

Read Timing

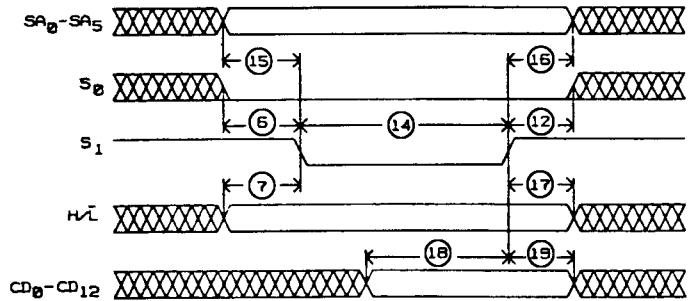

Write Timing

TYPICAL PERFORMANCE CURVES

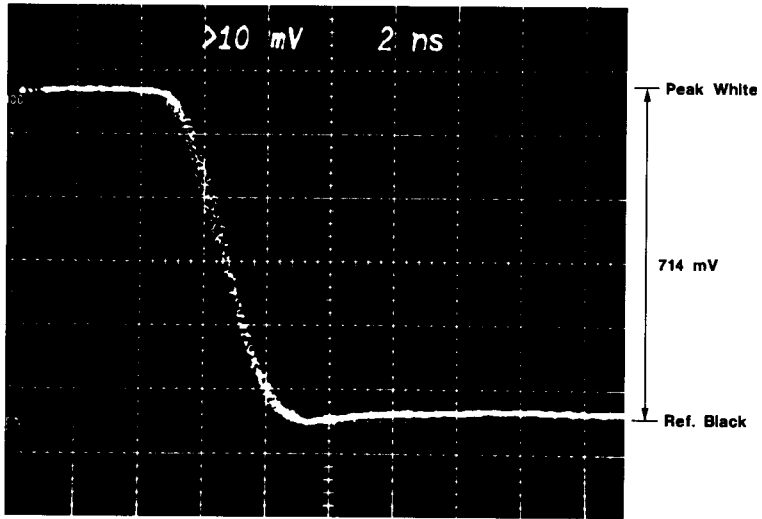

OP002200

G Output Falling Edge

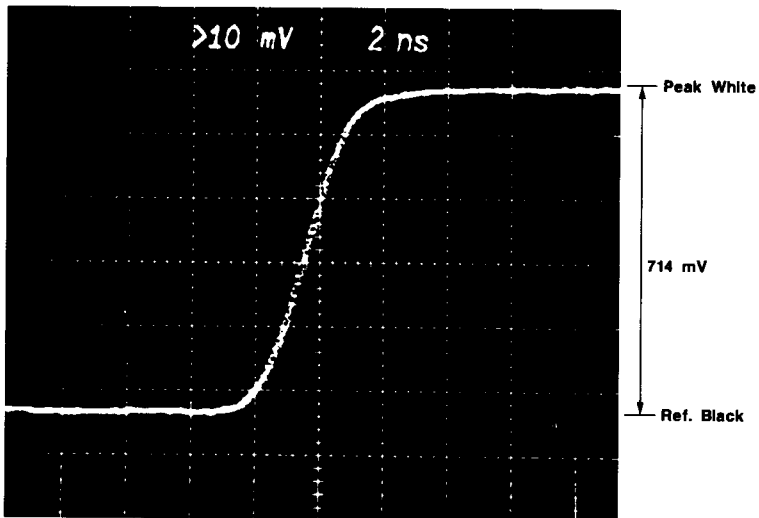

OP002190

G Output Rising Edge

PHYSICAL DIMENSIONS

PD 048

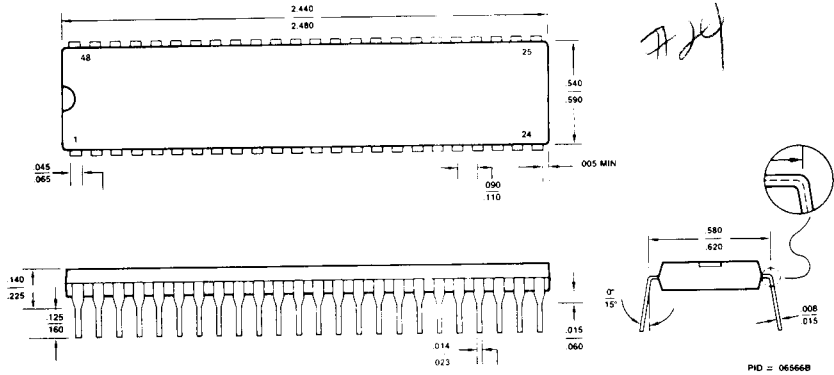

SD 048

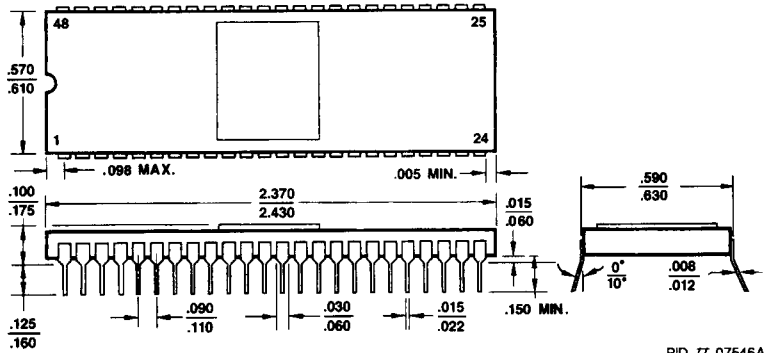

PL 068

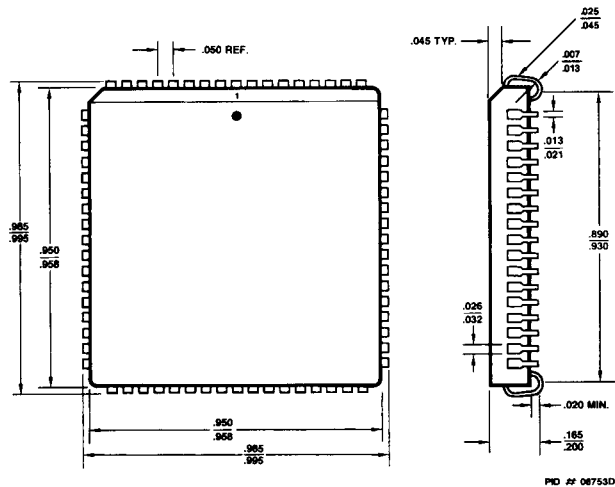

ADVANCED MICRO DEVICES DOMESTIC SALES OFFICES

ALABAMA	(205) 882-9122	MARYLAND	(301) 796-9310
ARIZONA,		MASSACHUSETTS	(617) 273-3970
Tempe	(602) 242-4400	MINNESOTA	(612) 938-0001
Tucson	(602) 792-1200	NEW JERSEY	(201) 299-0002
CALIFORNIA,		NEW YORK,	
El Segundo	(213) 640-3210	Liverpool	(315) 457-5400
Newport Beach	(714) 752-6262	Poughkeepsie (IBM only)	(914) 471-8180
San Diego	(619) 560-7030	Woodbury	(516) 368-0020
Sunnyvale	(408) 720-8811	NORTH CAROLINA,	(919) 847-8471
Woodland Hills	(818) 992-4155	OREGON	(503) 245-0080
COLORADO	(303) 741-2900	OHIO,	
CONNECTICUT,		Columbus	(614) 891-6455
	(203) 264-7800	PENNSYLVANIA,	
FLORIDA,		Allentown (AT&T only)	(215) 398-8006
Altamonte Springs	(305) 339-5022	Willow Grove	(215) 657-3101
Clearwater	(813) 530-9971	PUERTO RICO	(809) 764-4524
Ft. Lauderdale	(305) 484-8600	TEXAS,	
Melbourne	(305) 729-0496	Austin	(512) 346-7830
GEORGIA	(404) 449-7920	Dallas	(214) 934-9099
ILLINOIS	(312) 773-4422	Houston	(713) 785-9001
INDIANA	(317) 244-7207	WASHINGTON	(206) 455-3600
KANSAS	(913) 451-3115	WISCONSIN	(414) 782-7748

INTERNATIONAL SALES OFFICES

BELGIUM,		HONG KONG,	
Bruxelles	TEL: (02) 771 99 93	Kowloon	TEL: 3-695377
	FAX: (02) 762-3716		FAX: 1234276
	TLX: 61028		TLX: 50426
CANADA, Ontario,		ITALY, Milano	TEL: (02) 3390541
Kanata	TEL: (613) 592-0090		FAX: (02) 3498000
Willowdale	TEL: (416) 224-5193		TLX: 315286
	FAX: (416) 224-0056	JAPAN, Tokyo	TEL: (03) 345-8241
FRANCE,			FAX: 3425196
Paris	TEL: (01) 45 60 00 55		TLX: J24064 AMDTKOJ
	FAX: (01) 46 86 21 85	LATIN AMERICA,	
	TLX: 202053F	Ft. Lauderdale,	TEL: (305) 484-8600
GERMANY,			FAX: (305) 485-9736
Hannover area	TEL: (05143) 50 55		TLX: 5109554261 AMDFTL
	FAX: (05143) 55 53	SWEDEN, Stockholm	TEL: (08) 733 03 50
	TLX: 925287		FAX: (08) 733 22 85
München	TEL: (089) 41 14-0		TLX: 11602
	FAX: (089) 406490	UNITED KINGDOM,	
	TLX: 523883	Manchester area	TEL: (0925) 828008
Stuttgart	TEL: (0711) 62 33 77		FAX: (0925) 827693
	FAX: (0711) 625187		TLX: 628524
	TLX: 721882	London area	TEL: (04862) 22121
			FAX: (04862) 22179
			TLX: 859103

NORTH AMERICAN REPRESENTATIVES

CALIFORNIA		NEW MEXICO	
I ² INC.	OEM (408) 988-3400	THORSON DESERT STATES	(505) 293-8555
	DISTI (408) 496-6868	NEW YORK	
IDAHO		NYCOM, INC.	(315) 437-8343
INTERMOUNTAIN TECH MKGT	(208) 888-6071	OHIO	
INDIANA		Dayton	
SAI MARKETING CORP	(317) 241-9276	DOLFUSS ROOT & CO	(513) 433-6776
IOWA		Strongsville	
LORENZ SALES	(319) 377-4666	DOLFUSS ROOT & CO	(216) 238-0300
MICHIGAN		PENNSYLVANIA	
SAI MARKETING CORP	(313) 227-1786	DOLFUSS ROOT & CO	(412) 221-4420
NEBRASKA		UTAH	
LORENZ SALES	(402) 475-4660	R ² MARKETING	(801) 595-0631

Advanced Micro Devices reserves the right to make changes in its product without notice in order to improve design or performance characteristics. The performance characteristics listed in this document are guaranteed by specific tests, correlated testing, guard banding, design and other practices common to the industry. For specific testing details, contact your local AMD sales representative. The company assumes no responsibility for the use of any circuits described herein.

 **ADVANCED MICRO DEVICES** 901 Thompson Pl., P.O. Box 3453, Sunnyvale, CA 94088, USA © 1986 Advanced Micro Devices, Inc.
TEL: (408) 732-2400 • TWX: 910-339-9280 • TELEX: 34-6306 • TOLL FREE: (800) 538-8450 Printed in U.S.A. AIS-WCP-20M-07/86-0