

82S185/185A/185B 8K-Bit TTL Bipolar PROM (2048 × 4)

Military Bipolar Memory Products

Product Specification

DESCRIPTION

The 82S185 is field-programmable, which means that custom patterns are immediately available by following the Signetics Generic I fusing procedure. The standard 82S185 is supplied with all outputs at logical Low. Outputs are programmed to a logic High level at any specified address by fusing the Ni-Cr link matrix.

This device includes on-chip decoding and one chip enable input for memory expansion. It features 3-State outputs for optimization of word expansion in bused organizations.

FEATURES

- Address access time: 55ns max
- Input loading: -150µA max
- On-chip address decoding
- No separate fusing pins
- Unprogrammed outputs are Low level
- Fully TTL compatible
- One chip enable input
- Outputs: 3-State

APPLICATIONS

- Sequential controllers
- Control store
- Random logic
- Code conversion

ORDERING INFORMATION

DESCRIPTION	ORDER CODE
18-pin Ceramic Dual-In-Line 300mil-wide	82S185/BVA 82S185A/BVA 82S185B/BVA
18-pin Ceramic Flat Pack	82S185/BYA 82S185A/BYA 82S185B/BYA

ABSOLUTE MAXIMUM RATINGS

SYMBOL	PARAMETER	RATING	UNIT
V _{CC}	Supply voltage	+7	V _{DC}
V _I	Input voltage	+5.5	V _{DC}
V _O	Output voltage Off-State	+5.5	V _{DC}
T _A	Operating temperature range	-55 to +125	°C
T _{STG}	Storage temperature range	-65 to +150	°C

PIN CONFIGURATION

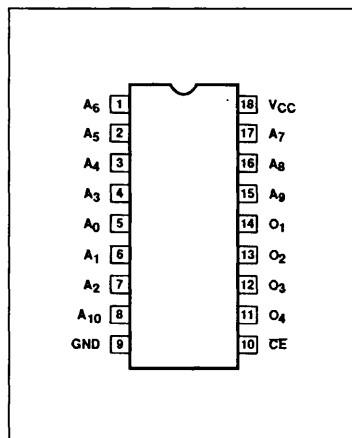

BLOCK DIAGRAM

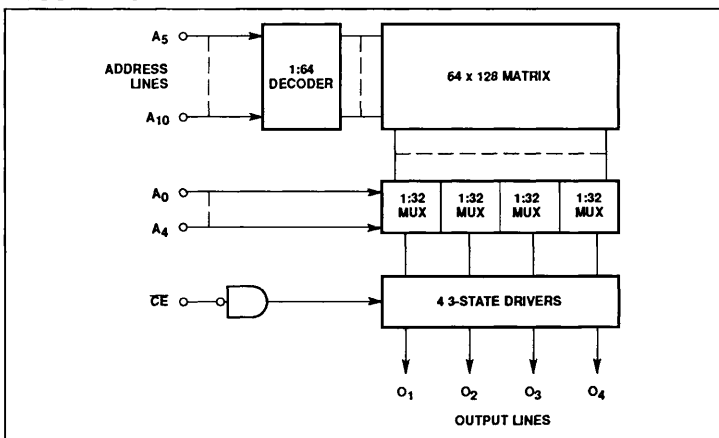

8K-Bit TTL Bipolar PROM (2048 × 4)

82S185/185A/185B

DC ELECTRICAL CHARACTERISTICS $-55^{\circ}\text{C} \leq T_A \leq +125^{\circ}\text{C}$, $4.5\text{V} \leq V_{\text{CC}} \leq 5.5\text{V}$

SYMBOL	PARAMETER	TEST CONDITIONS ^{1,2}	LIMITS			UNIT	
			Min	Typ ⁵	Max		
Input voltage							
V _{IL}	Low	V _{CC} = 4.5V, I _I = -18mA	2.0		0.8	V	
V _{IH}	High						
V _{IK}	Clamp						
Output voltage							
V _{OL}	Low	V _{CC} = 4.5V, CE = Low I _O = 16mA I _O = -2mA	2.4		0.5	V	
V _{OH}	High						
Input current							
I _{IL}	Low	V _{CC} = 5.5V V _I = 0.45V			-150	μA	
I _{IH}	High						V _I = 5.5V
Output current							
I _{OZ}	Hi-Z state	V _{CC} = 5.5V CE = High, V _O = 0.4V CE = High, V _O = 5.5V			-40	μA	
I _{OS}	Short circuit ³						CE = Low, V _O = 0V, High stored
Supply current							
I _{CC}		CE = High, V _{CC} = 5.5V			90	130	mA
Capacitance⁶							
C _{IN}	Input	CE = High, V _{CC} = 5.0V V _I = 2.0V V _O = 2.0V			5	10	pF
C _{OUT}	Output						

AC ELECTRICAL CHARACTERISTICS $-55^{\circ}\text{C} \leq T_A \leq +125^{\circ}\text{C}$, $4.5\text{V} \leq V_{\text{CC}} \leq 5.5\text{V}$

SYMBOL	PARAMETER	TO	FROM	LIMITS			UNIT					
				Min	Typ ⁵	Max						
t _{AA}	Access time ⁴	185	Output	Address		70	115	ns				
									185A	25	55	ns
									185B	40	90	ns
t _{CE}	Access time ⁴	185/185B	Output	Chip Enable		30	50	ns				
									185A	15	30	ns
t _{CD}	Disable time	185/185B	Output	Chip Disable		30	50	ns				
									185A	15	30	ns

NOTES:

- All voltages are with respect to network ground terminal.
- Positive current is defined as into the terminal referenced.
- Duration of short circuit should not exceed 1 second.
- Tested at an address cycle time of 1μs.
- Typical values are at V_{CC} = 5V, T_A = +25°C.
- Guaranteed, but not tested.

8K-Bit TTL Bipolar PROM (2048 × 4)

82S185/185A/185B

TEST LOAD CIRCUITS

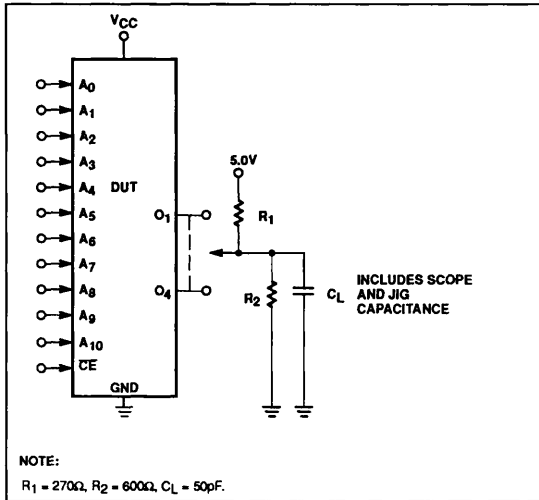

VOLTAGE WAVEFORMS

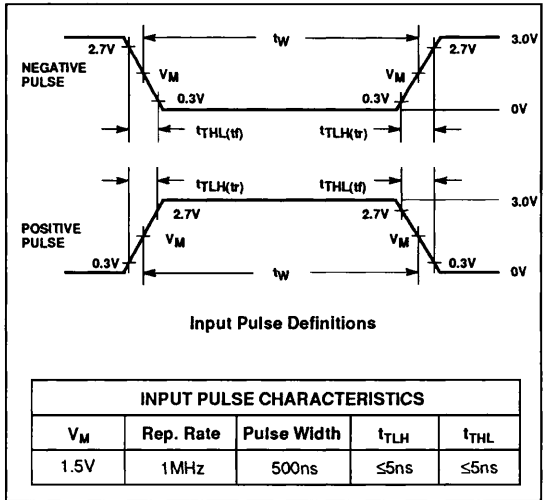

TIMING DIAGRAMS

