

# FAN7527

## Power Factor Correction Controller

### Features

- Internal Startup Timer
- Internal R/C filter which eliminates the Need for an External R/C filter
- Overvoltage Comparator eliminates Runaway Output Voltage
- Zero Current Detector
- One Quadrant Multiplier
- Trimmed 1.5% Internal Bandgap Reference
- Under Voltage Lock Out with 5V of Hysteresis
- Totem Pole Output with High State Clamp
- Low Startup and Operating Current
- 8-Pin DIP or 8-Pin SOP
- Over Voltage Protection Function ( Soft OVP, Dynamic OVP, Static OVP )

### Applications

- Electronic Ballast
- SMPS

### Description

The KA7527 provides simple and high performance active power factor correction. KA7527 is optimized for electronic ballast and low power, high density power supplies requiring a minimum board area, reduced component count and low power dissipation. Addition of internal R/C filter eliminates the need for an external R/C filter. Internal clamping of the error amplifier and multiplier outputs improves turn on overshoot characteristics and current limiting. Special circuitry has also been added to prevent no load runaway conditions. The output drive clamping circuit limits overshoot of the power MOSFET gate drive Independent of supply voltage, so that it greatly enhance the system reliability.

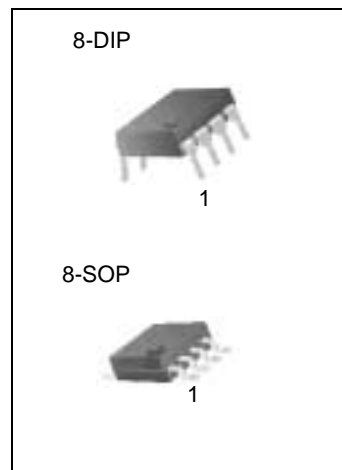

Internal Block Diagram

Preliminary Specification

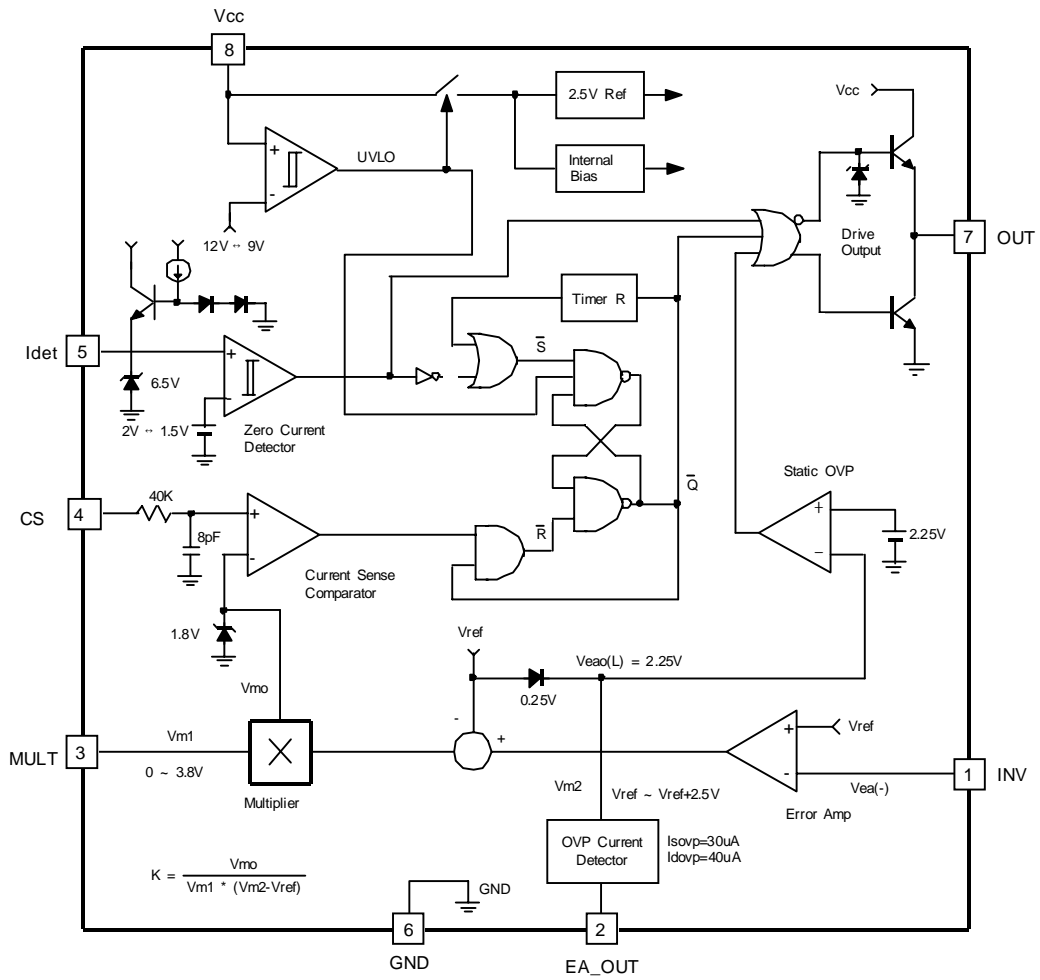

## PIN Description

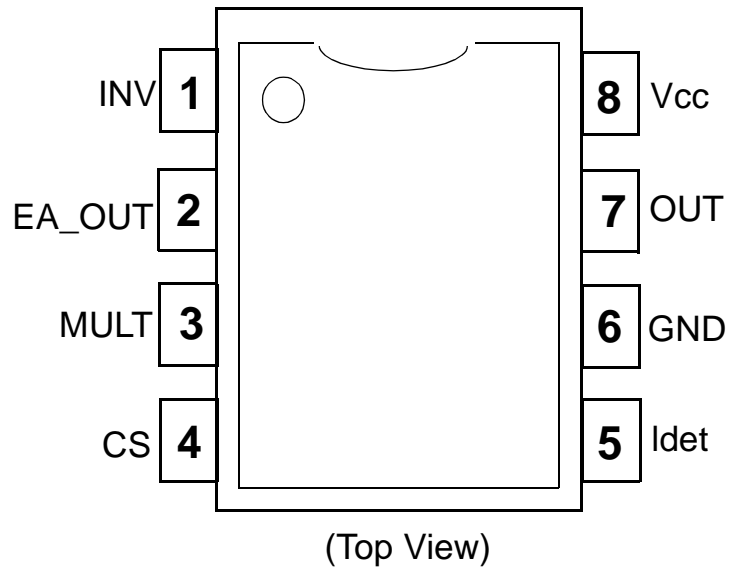

Pin Number	Pin Name	Pin Function Description
1	INV	Voltage Feedback Negative Input
2	EA_OUT	Error Amp Output
3	MULT	Multiplier Input
4	CS	Current Sense Input
5	Idet	Zero Current Detect Input
6	GND	Ground
7	OUT	Drive Output
8	Vcc	Supply Voltage Input

**Absolute Maximum Ratings (Ta=25°C)**

Characteristics	Symbol	Value	Unit
Supply Voltage	V <sub>CC</sub>	30	V
Peak Drive Output Current	I <sub>OH</sub> , I <sub>OL</sub>	±500	mA
Driver Output Clamping Diodes V <sub>o</sub> > V <sub>CC</sub> or V <sub>o</sub> < -0.3V	I <sub>clamp</sub>	±10	mA
Detector Clamping Diodes	I <sub>det</sub>	±10	mA
Error Amp, Multiplier And Comparator Input Voltages	V <sub>in</sub>	-0.3 to 6	V
Operating Junction Temperature	T <sub>j</sub>	150	°C
Operating Temperature Range	T <sub>opr</sub>	-25 to 125	°C
Storage Temperature Range	T <sub>stg</sub>	-65 to 150	°C
Power Dissipation	P <sub>d</sub>	0.8	W

**Temperature Characteristics (-25°C ≤ Ta ≤ 125°C)**

Characteristics	Symbol	Min.	Typ.	Max.	Unit
Temperature Stability for Reference Voltage (V <sub>ref</sub> )	Δ V <sub>ref</sub>	-	20	-	mV
Temperature Stability for Multiplier Gain (K)	Δ K/ΔT	-	0.2	-	%/°C

## Electronic Characteristics

( $V_{CC}=14V$ ,  $-25^{\circ}C \leq T_a \leq 125^{\circ}C$ , unless otherwise stated.)

Characteristics	Symbol	Test Condition	Min.	Typ.	Max.	Unit
<b>&lt; UNDER VOLTAGE LOCK OUT SECTION &gt;</b>						
Start Threshold Voltage	$V_{th(st)}$	$V_{CC}$ Increasing	11	12	13	V
UVLO Hysteresis	$HY(st)$	-	2.5	3	3.5	V
<b>&lt; SUPPLY CURRENT SECTION &gt;</b>						
Start-up Supply Current	$I_{st}$	$V_{CC} = V_{th(st)} - 0.2V$	20	60	100	$\mu A$
Operating Supply Current	$I_{CC}$	Output not switching	-	3	6	mA
Operating Current at OVP	$I_{CC(ovp)}$	$V_{inv} = 3V$	-	1.7	4	mA
Dynamic Operating Supply Current	$I_{dCC}$	50KHz, $C_I = 1nF$	-	4	8	mA
<b>&lt; ERROR AMPLIFIER SECTION &gt;</b>						
Voltage Feedback Input Threshold	$V_{ref}$	$I_{ref} = 0mA$ , $T_a = 25^{\circ}C$	2.465	2.5	2.535	V
		$0 \leq T_a \leq 125^{\circ}C$	2.44	2.5	2.56	V
Line Regulation	$\Delta V_{ref1}$	$14V \leq V_{CC} \leq 25V$	-	0.1	10	mV
Temperature Stability Of $V_{ref}$ (Note1)	$\Delta V_{ref3}$	$-25 \leq T_a \leq 125^{\circ}C$	-	20	-	mV
Input Bias Current	$I_{b(ea)}$	-	-0.5	-	0.5	$\mu A$
Output Source Current	$I_{source}$	$V_{m2} = 4V$	-2	-4.5	-	mA
Output Sink Current	$I_{sink}$	$V_{m2} = 4V$	2	4.5	-	mA
Output Upper Clamp Voltage	$V_{eao(H)}$	$I_{source} = 0.1mA$	-	6	-	V
Output Lower Clamp Voltage	$V_{eao(L)}$	$I_{sink} = 0.1mA$	-	2.25	-	V
Large Signal Open Loop Gain (Note2)	$G_v$	-	60	80	-	dB
Power Supply Rejection Ratio (Note3)	PSRR	$14V \leq V_{CC} \leq 25V$	60	80	-	dB
Unity Gain Bandwidth (Note4)	GBW	-	-	1	-	MHz
Slew Rate (Note5)	SR	-	-	0.6	-	V/ $\mu s$
<b>&lt; MULTIPLIER SECTION &gt;</b>						
Input Bias Current (Pin3)	$I_{b(m)}$	-	-0.5	-	0.5	$\mu A$
M1 Input Voltage Range (Pin3)	$\Delta V_{m1}$	-	0	-	3.8	V
M2 Input Voltage Range (Pin2)	$\Delta V_{m2}$	-	$V_{ref}$	-	$V_{ref} + 2.5$	V
Multiplier Gain (Note6)	K	$V_{m1} = 1V$ , $V_{m2} = 3.5V$	0.36	0.44	0.52	1/V
Maximum Multiplier Output Voltage	$V_{omax(m)}$	$V_{inv} = 0V$ , $V_{m1} = 4V$	1.65	1.8	1.95	V
Temperature Stability Of K (Note7)	$\Delta K/\Delta T$	$-25 \leq T_a \leq 125^{\circ}C$	-	0.2	-	%/ $^{\circ}C$

## Electrical Characteristics

( $V_{CC} = 14V$ ,  $-25^{\circ}C \leq T_a \leq 125^{\circ}C$ , unless otherwise stated.)

Characteristics	Symbol	Test Condition	Min.	Typ.	Max.	Unit
<b>&lt; CURRENT SENSE SECTION &gt;</b>						
Input Offset Voltage (Note8)	$V_{io(cs)}$	$V_{m1}=0V$ , $V_{m2} = 2.2V$	-10	3	10	mV
Input Bias Current	$I_{b(cs)}$	$0V \leq V_{cs} \leq 1.7V$	-1	-0.1	1	$\mu A$
Current Sense Delay To Output (Note9)	$t_{b(cs)}$	-	-	200	500	ns
<b>&lt; DETECT SECTION &gt;</b>						
Input Voltage Threshold	$V_{th(det)}$	$V_{det}$ Increasing	1.7	2	2.3	V
Detect Hysteresis	$H_{Y(det)}$	-	0.2	0.5	0.8	V
Input Low Clamp Voltage	$V_{clamp(l)}$	$I_{det} = -100\mu A$	0.45	0.75	1	V
Input High Clamp Voltage	$V_{clamp(h)}$	$I_{det} = 3mA$	7	7.5	8	V
Input Bias Current	$I_{b(det)}$	$1V \leq V_{det} \leq 5V$	-1	-0.1	1	$\mu A$
Input High/low Clamp Diode Current	$I_{clamp(d)}$	-	-	-	$\pm 3$	mA
<b>&lt; OUTPUT SECTION &gt;</b>						
Output Voltage High	$V_{oh}$	$I_o = -10mA$	10.5	11	-	V
Output Voltage Low	$V_{ol}$	$I_o = 10mA$	-	0.8	1	V
Rising Time (Note11)	$t_r$	$C_I = 1nF$	-	130	200	ns
Falling Time (Note12)	$t_f$	$C_I = 1nF$	-	50	120	ns
Maximum Output Voltage	$V_{omax(o)}$	$V_{CC} = 20V$	12	14	16	V
Output Voltage With $U_{vlo}$ Activated	$V_{omax(o)}$	$V_{CC} = 5V$ , $I_o = 100\mu A$	-	-	1	V
<b>&lt; RESTART TIMER SECTION &gt;</b>						
Restart Time Delay	$t_{d(rst)}$	$V_{m1} = 1V$ , $V_{m2} = 3.5V$	-	500	-	$\mu s$
<b>&lt; OVER VOLTAGE PROTECTION SECTION &gt;</b>						
Soft OVP Detecting Current	$I_{sovp}$	-	25	30	35	$\mu A$
Dynamic OVP Detecting Current	$I_{dovp}$	-	35	40	45	$\mu A$
Static OVP Threshold Voltage	$V_{ovp}$	$V_{inv} = 2.7V$	2.1	2.25	2.4	V

## Typical Performance Characteristics

Preliminary Specification

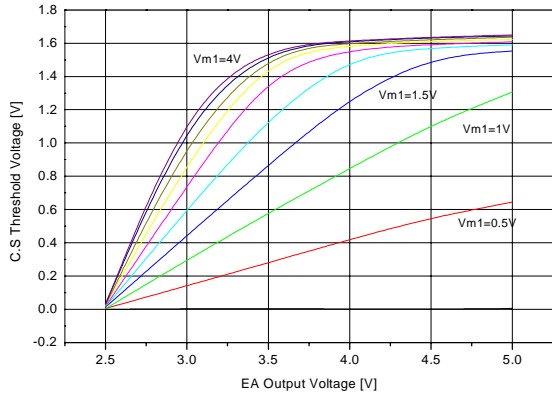

Figure 1. EA Output Voltage vs C.S. Threshold

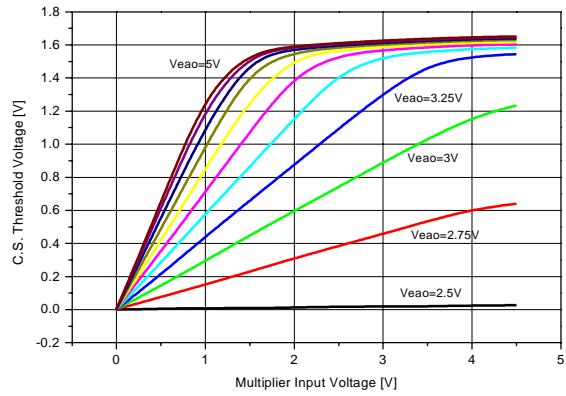

Figure 2. Multiplier Input Voltage vs C.S. Threshold

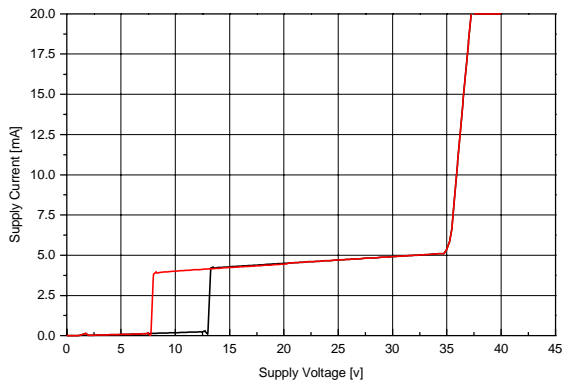

Figure 3. Supply Current vs Supply Voltage

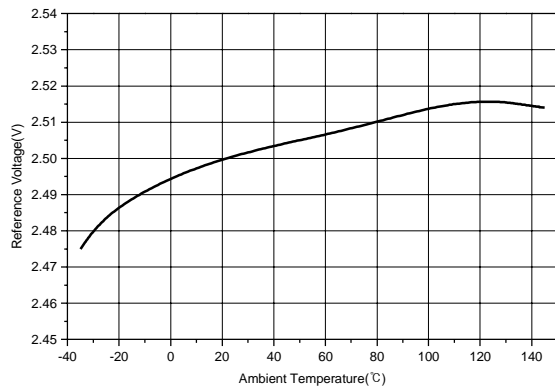

Figure 4. Reference Voltage vs Temperature

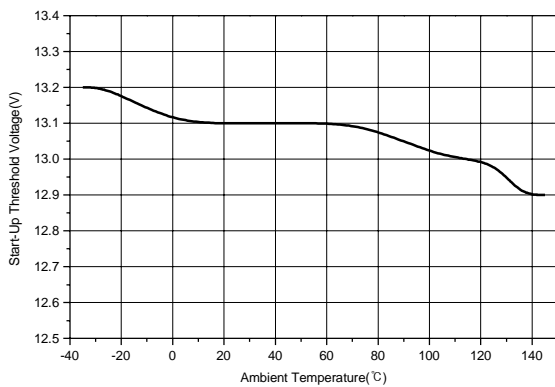

Figure 5. Start-Up Threshold vs Temperature

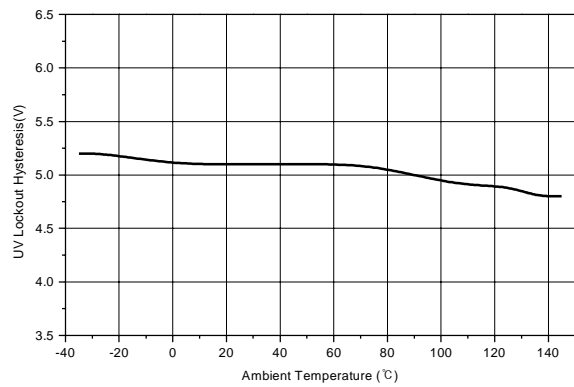

Figure 6. UV Lockout Hysteresis vs Temperature

Typical Performance Characteristics (continued)

Preliminary Specification

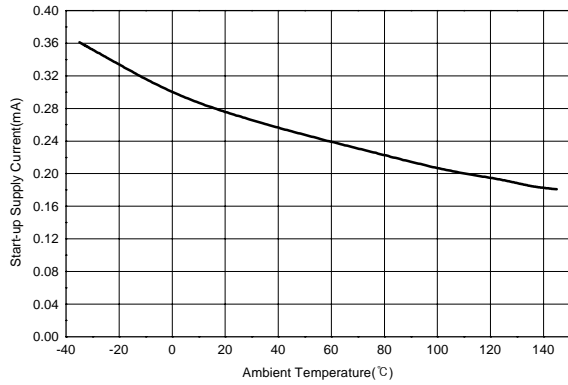

Figure 7. Start-Up Supply Current vs Temperature

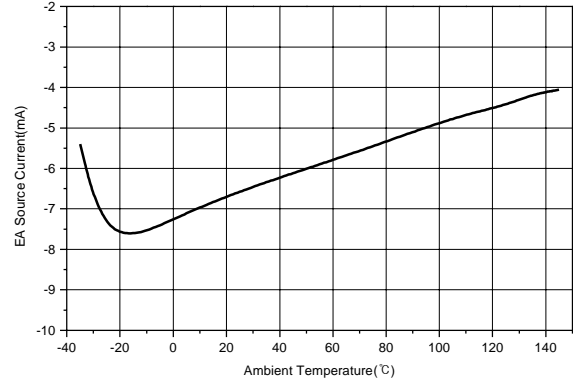

Figure 8. EA Source Current vs Temperature

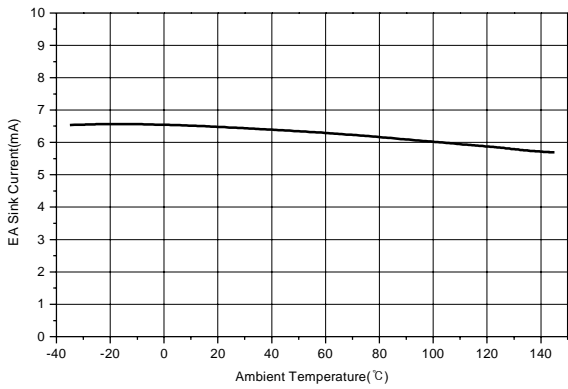

Figure 9. EA Sink Current vs Temperature

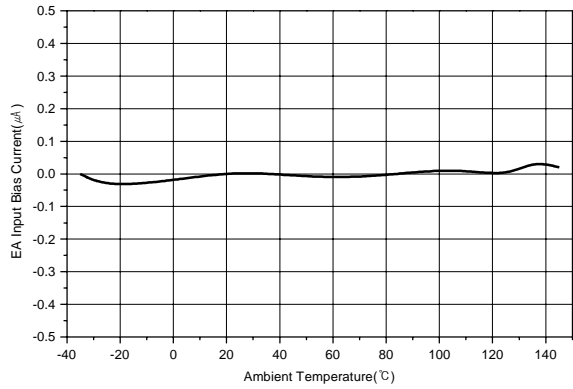

Figure 10. EA Input Bias Current vs Temperature

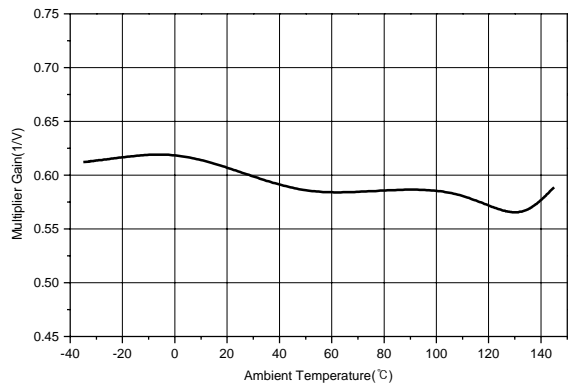

Figure 11. Multiplier Gain vs Temperature

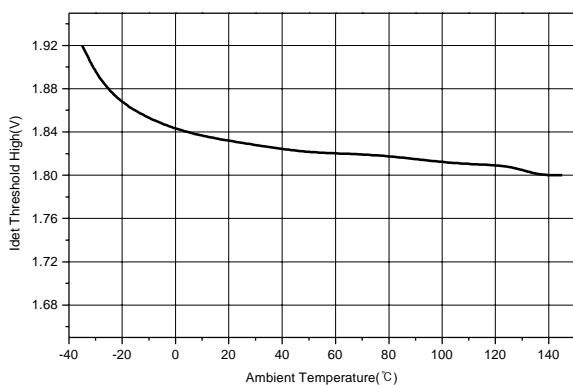

Figure 12. Idet Threshold Voltage vs Temperature



Typical Performance Characteristics (continued)

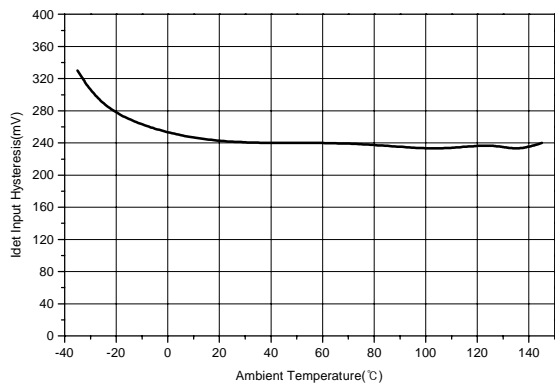

Figure 13. Idet Input Hysteresis vs Temperature

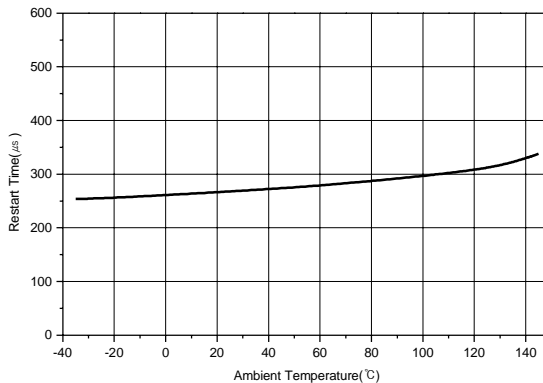

Figure 14. Restart Time vs Temperature

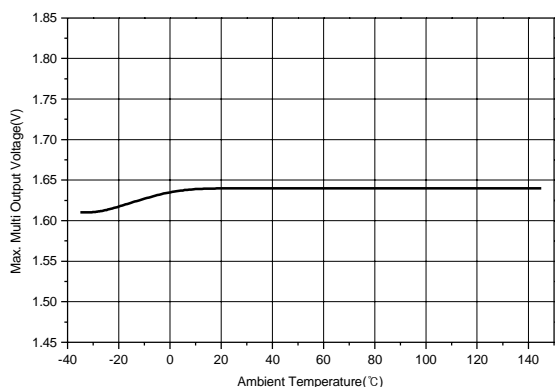

Figure 15. Max. Mult. Output Voltage vs Temperature

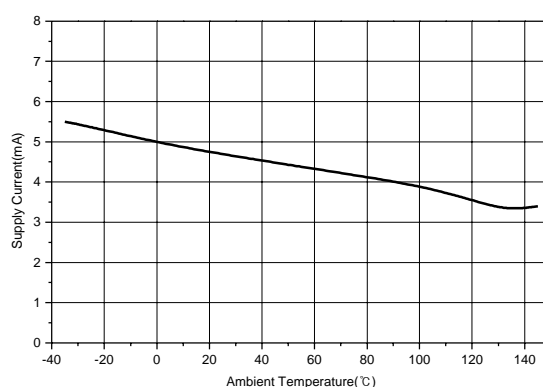

Figure 16. Supply Current vs Temperature

Preliminary Specification

## Operating Description

KA7527 is high performance, critical conduction, current-mode power factor controller specifically designed for use in off-line active preconverters with minimal external components. This device provides the necessary features which are required to significantly enhance poor power factor loads by keeping the ac line current sinusoidal and in phase with the line voltage.

KA7527 contains many of the building blocks and protection features that are employed in modern high performance current mode power supply controllers. A description of each of the function blocks is given below.

### START-UP

An Undervoltage Lockout comparator has been incorporated to guarantee that IC is fully functional before enabling the output stage. The positive power supply terminal (Vcc) is monitored by the UVLO comparator with the upper threshold set at 13V and the lower threshold at 8V. In the stand-by mode, with Vcc at 12.5V, the required supply current is less than 0.3mA. This large hysteresis and low start-up current allow the implementation of efficient bootstrap start-up techniques, making this device ideally suited for wide range off-line preconverter applications.

Fig.1.1 shows the start-up circuit. Circuit operation is as follows:

The start-up capacitor (Cst) is charged by current through start-up resistor (Rst) minus the start-up current drawn by the IC. Once the capacitor voltage reaches the start-up threshold, the IC turns on, starting the switching of the MOSFET. The operation of the IC demands an increase in operating current which results in discharging the capacitor. Before the start-up capacitor voltage is discharged below hysteresis voltage, the auxiliary winding voltage takes over as the supply voltage as shown in Fig. 1.2.

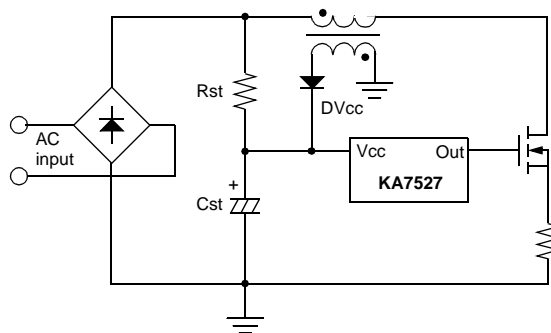

Fig.1.1 Start-up Circuit

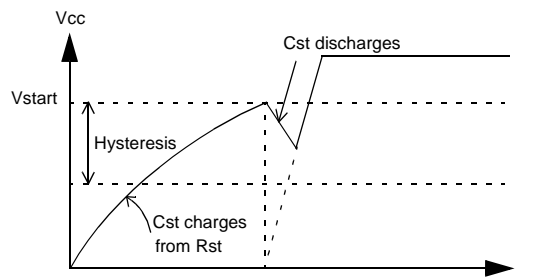

Fig.1.2 Start-up Capacitor Voltage

## Error Amplifier

An Error Amplifier with access to the inverting input and output is provided. The noninverting input is internally biased at 2.5V and is not pinned out. The output voltage of the power factor converter is typically divided down and monitored by the inverting input. The error amp output is internally connected to the multiplier and is pinned out for external loop compensation. Typically, the loopbandwidth is set below 20Hz, so that the amplifier's output voltage is relatively constant over a given ac line cycle. In effect, the error amp monitors the average output voltage of the converter over several line cycles. Input bias current (0.5uA, max) can cause an output voltage error that is equal to the product of the input bias current and the value of the upper divider resistor, R1 in Fig. 2.1.

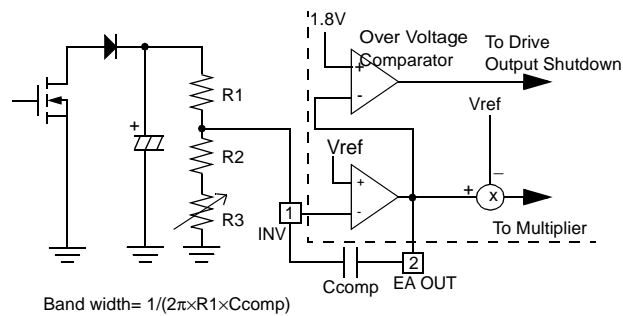

Fig.2.1 Error Amp and Over Voltage Comparator

## Over Voltage Protection

The low bandwidth (typically below 20Hz) characteristic of Error Amplifier control loop results in output voltage runaway condition. This condition can occur during initial start-up, sudden load removal, or during output arcing. The over voltage comparator monitors the output voltage of the error amplifier. When load is removed, error amp output swings lower than 1.8V, comparator is triggered high and output driver is turned off till the error amp inverting input voltage drops below 2.5V. At this point, the error amp output swings positive, turns the output driver back on. .

## Multiplier

A single quadrant, two input multiplier is the critical element that enables this device to get power factor correction. One input of multiplier (Pin 3) is connected to an external resistor divider which monitors the rectified ac line. The other input is internally driven by a DC voltage which is the difference of error amplifier output (Pin 2) and reference voltage, Vref. The multiplier is designed to have an extremely linear transfer curve over a wide dynamic range, 0V to 3.8V for Pin 3, and 2.5V to 4.5V for error amplifier output under all line and load conditions.

The multiplier output controls the current sense comparator threshold as the ac voltage traverses sinusoidally from zero to peak line. This allows the inductor peak current to follow the ac line thus forcing the average input current to be sinusoidal. In other words, this has the effect of forcing the MOSFET on-time to track the input line voltage, resulting in a fixed drive output on-time, thus making the preconverter load appear to be resistive to the ac line.

The equation below describes the relationship between multiplier output and inputs.

$$V_{mo} = K \times V_{m1} \times (V_{m2} - V_{ref})$$

K : Multiplier gain

V<sub>m1</sub>: Voltage at Pin 3

V<sub>m2</sub>: Error amp output voltage

V<sub>mo</sub>: Multiplier output voltage

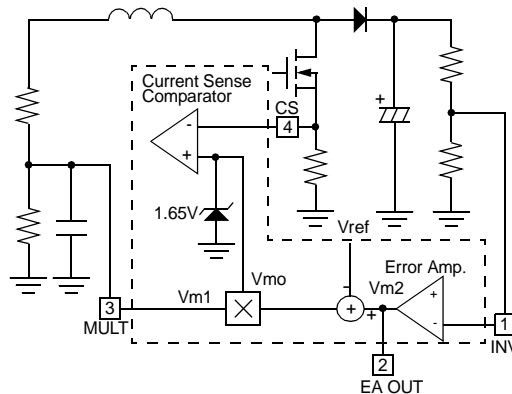

Fig.3.1 Multiplier Block

### Current Sense Comparator

The current sense comparator adopt the RS latch configuration to ensure that only a single pulse appears at the drive output during a given cycle. MOSFET drain current is converted to voltage using an external sense resistor in series with the external power MOSFET. When sense voltage exceeds the threshold set by the multiplier output, the current sense comparator terminates the gate drive to the MOSFET and resets the PWM latch. The latch insures that the output remains in a low state after the MOSFET drain current falls back to zero.

The peak inductor current under normal operating conditions is controlled by the multiplier output, Vmo. Abnormal operating conditions occur during preconverter start-up at extremely high line or as output voltage sensing is lost.

Under these conditions, the multiplier output and current sense threshold will be internally clamped to 1.65V. Therefore, the maximum peak switch current is limited to:

$$I_{pk(max)} = 1.65V / R_{sense}$$

An internal R/C filter has been included to attenuate any high frequency noise that may be present on the current waveform. This circuit block eliminates the need for an external R/C filter otherwise required for proper operation of the circuit.

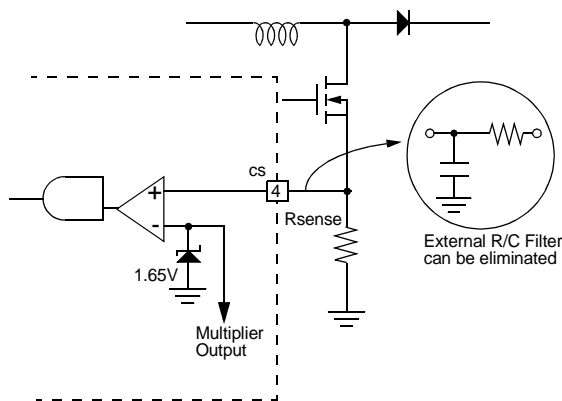

Fig. 4.1 Current Sense Circuit

### Zero Current Detector

KA7527 operates as a critical conduction current mode controller. The power MOSFET is turned on by the zero current detector and turned off when the peak inductor current reaches the threshold level established by the multiplier output. The slope of the inductor current is indirectly detected by monitoring the voltage across a separate winding and connecting it to the zero current detector Pin 5.

Once the inductor current reaches ground level, the voltage across the winding reverses polarity. When the Idet input falls below 1.8V, the comparator output is triggered to the low state.

To prevent false tripping, 240mV of hysteresis is provided. The zero current detector input is internally protected by two clamps.

The upper 7.5V clamp prevents input over voltage breakdown while the lower 0.75V clamp prevents substrate injection. An internal current limit resistor protects the lower clamp transistor in case the Idet pin is accidentally shorted to ground.

A watchdog timer function was added to the IC to eliminate the need for an external oscillator when used in stand-alone applications. The timer provides a means to automatically start or restart the preconverter if the drive output has been off for more than 300us after the inductor current reaches zero.

### Drive Output

The KA7527 contains a single totem-pole output stage specifically designed for direct drive of power MOSFET. The drive output is capable of up to 500mA peak current with a typical rise and fall time of 130ns, 50ns each with a 1.0nF load. Additional internal circuitry has been added to keep the drive output in a sinking mode whenever the UVLO is active. This characteristic eliminates the need for an external gate pull-down resistor. Internal voltage clamping ensures that output driver is always lower than 13V when supply voltage variation exceeds more than rated Vgs threshold (typ 20V) of the external MOSFET. This eliminates an external zener diode and extra power dissipation associated with it that otherwise is required for reliable circuit operation.

## APPLICATION CIRCUIT #1

< 90 ~ 265VAC Input, 400VDC, 32W×2 Lamps Self-oscillating Ballast >

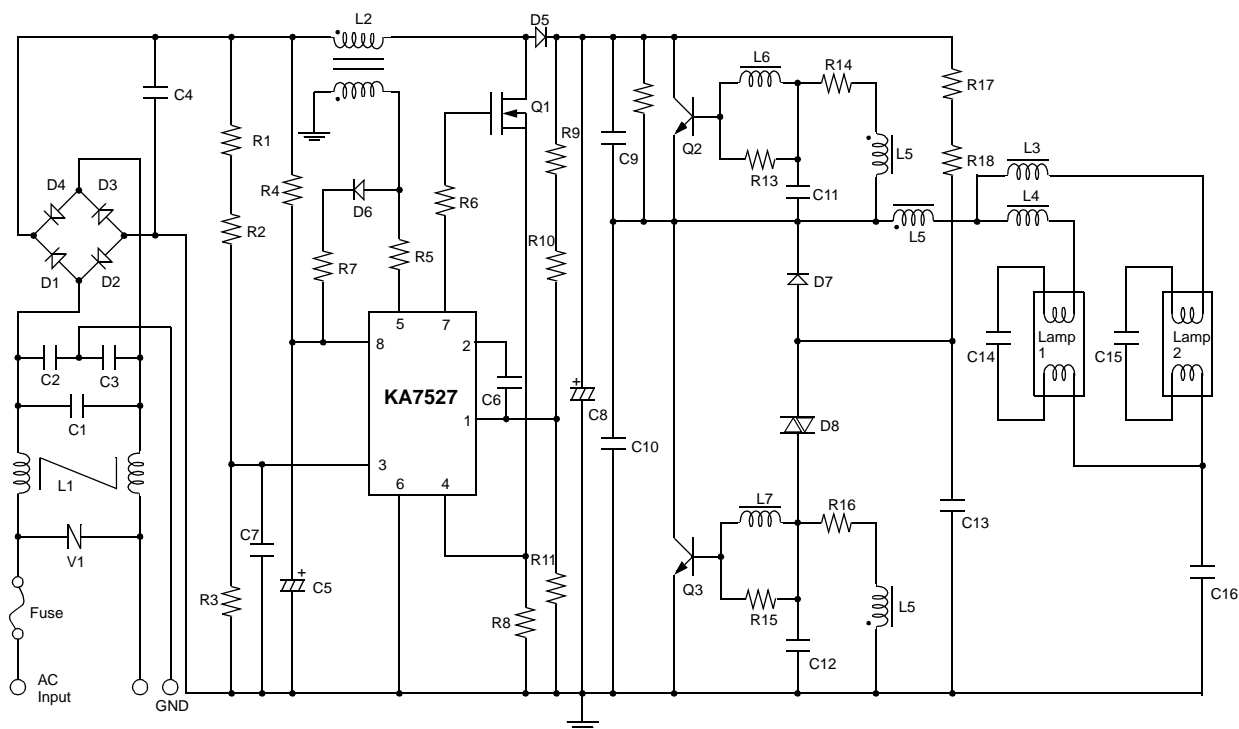

Preliminary Specification

## Component Listing (for Application circuit #1)

Reference	Value	Part Number	Manufacturer
R1, 2	1.2M $\Omega$ -F, 1/4W	26mm Type	-
R3	11k $\Omega$ -F, 1/4W	26mm Type	-
R4	150k $\Omega$ , 1/2W	26mm Type	-
R5	22k $\Omega$ -J, 1/4W	26mm Type	-
R6, 13, 15	47 $\Omega$ -J, 1/4W	26mm Type	-
R7	3.3 $\Omega$ , 1/4W	26mm Type	-
R8	1 $\Omega$ -J, 1W	26mm Type	-
R9	180k $\Omega$ -F, 1/4W	26mm Type	-
R10	820k $\Omega$ -F, 1/4W	26mm Type	-
R11	6.8k $\Omega$ -F, 1/4W	26mm Type	-
R12, 17, 18	390k $\Omega$ -J, 1/4W	26mm Type	-
R14, 16	8.2 $\Omega$ -J, 1/4W	26mm Type	-
C1	0.15 $\mu$ F, 630V	MEP-CAP	-
C2, 3	2200pF, 3000V	Y-CAP	-
C4	0.22 $\mu$ F, 630V	MPE-CAP	-
C5	22 $\mu$ F, 35V	Electrolytic	-
C6	0.33 $\mu$ F, 25V	Ceramic	-
C7	1000pF, 50V	Ceramic	-
C8	47 $\mu$ F, 450V	Electrolytic	-
C9	4700pF, 630V	PPF-CAP	-
C10	2200pF, 630V	PPF-CAP	-
C11, 12	0.15 $\mu$ F, 63V	MPF-CAP	-
C13	0.1 $\mu$ F, 50V	Ceramic	-
C14, 15	8200pF, 1000V	PP-CAP	-
C16	0.15 $\mu$ F, 630V	MEP-CAP	-
D1, 2, 3, 4, 7	1000V, 1A	IN4007GP	-
D5	1000V, 1.5A	BYV26C	Philips
D6	75V, 150mA	IN4148	-
D8	-	N413N (DIAC)	-
L1	DR 10 $\times$ 12	DIT-010	-
L2	EI 2519	DBT-002	-
L3, 4	EI 2820	DPT-086	-
L5	SB5S 8 $\times$ 3 $\times$ 4	DDT-005	-
L6, 7	10 $\mu$ H	BS24-100K	-
Fuse	-	52NM250V, 3A	-
V1	430V	INR140, 431	-
IC1	-	KA7527	FairChild
Q1	500V, 4.5A	QFP6N50	FairChild
Q2, 3	400V, 5A	KSC5305D	FairChild

## Application Circuit #2

< 90 ~ 265VAC Input, 400VDC, 32W×2 Lamps External-oscillating Ballast >

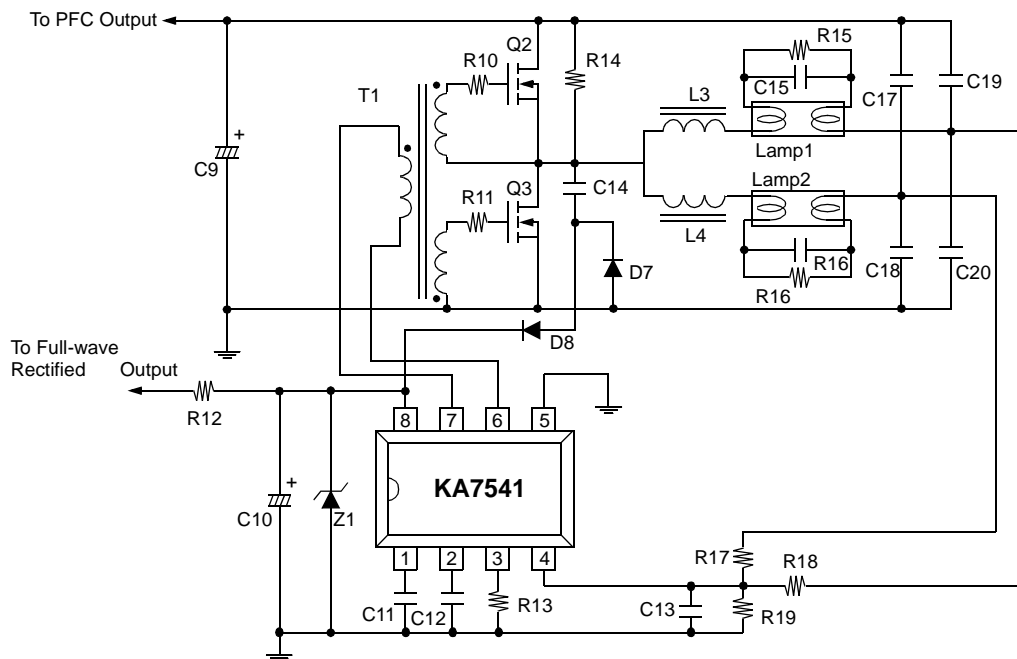
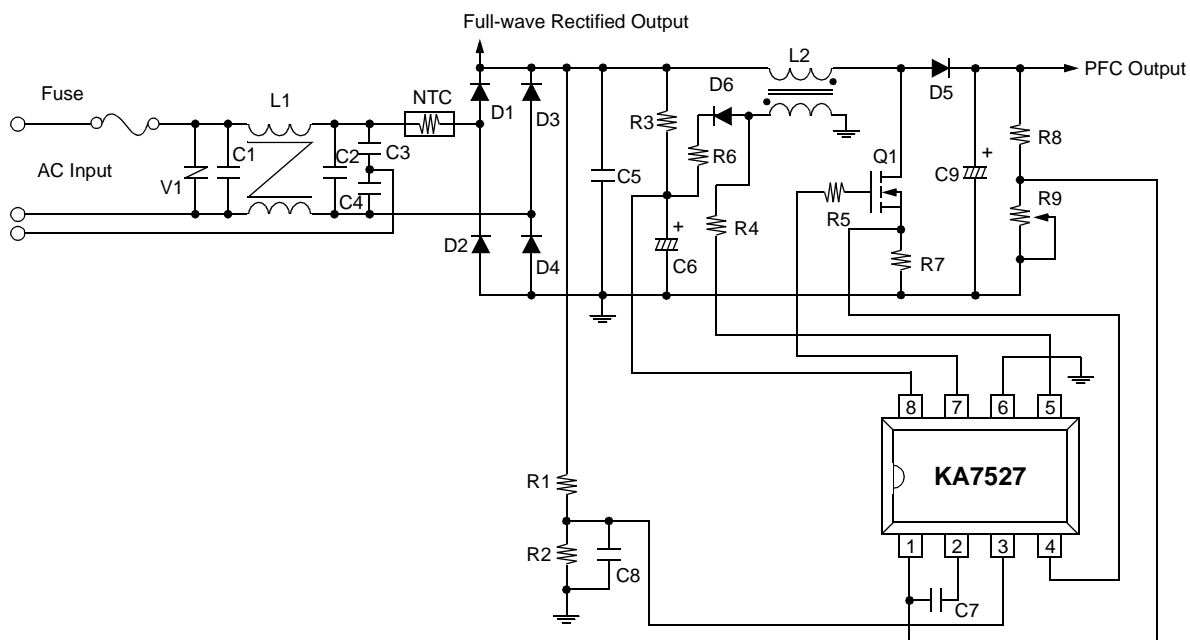

Preliminary Specification

## Component Listing (for Application Circuit #2)

Reference	Value	Part Number	Manufacturer
R1	2.2M $\Omega$ -F, 1/4W	26mm Type	-
R2	12k $\Omega$ -F, 1/4W	26mm Type	-
R3, 12	150k $\Omega$ , 1/2W	26mm Type	-
R4	22k $\Omega$ -J, 1/4W	26mm Type	-
R5, 10, 11	47 $\Omega$ -J, 1/4W	26mm Type	-
R6	3.3 $\Omega$ , 1/4W	26mm Type	-
R7	1 $\Omega$ -J, 1W	26mm Type	-
R8	1.2M $\Omega$ -F, 1/4W	26mm Type	-
R9	10k $\Omega$ Variable Resistor	-	-
R13	22k $\Omega$ -F, 1/4W	26mm Type	-
R14	180k $\Omega$ -J, 1/4W	26mm Type	-
R15, 16	330k $\Omega$ -J, 1/4W	26mm Type	-
R17, 18	680k $\Omega$ -J, 1/4W	26mm Type	-
R19	8.2k $\Omega$ -J, 1/4W	26mm Type	-
C1, 2	0.15 $\mu$ F, 630V	MEP-CAP	-
C3, 4	2200pF, 3000V	Y-CAP	-
C5	0.1 $\mu$ F, 400V	MPE-CAP	-
C6	22 $\mu$ F, 35V	Electrolytic	-
C7	0.33 $\mu$ F, 25V	MPE-CAP	-
C8	0.01 $\mu$ F, 25V	MPE-CAP	-
C9	47 $\mu$ F, 450V	Electrolytic	-
C10	47 $\mu$ F, 35V	Electrolytic	-
C11	0.22 $\mu$ F, 25V	MPE-CAP	-
C12	180pF, 25V	Ceramic	-
C13	0.1 $\mu$ F, 25V	MPE-CAP	-
C14	1000pF, 630V	MPE-CAP	-
C15, 16	4700pF, 1000V	MPE-CAP	-
C17, 18, 19, 20	6800pF, 630V	MPE-CAP	-
D1, 2, 3, 4	1000V, 1A	1N4007	-
D5	FRD(25nS)	BYV26C	Philips
D6	75V, 150mA	1N4148	-
D7,8	1000V, 1.5A	1N4937	-
L1	80mH	BSF2125	-
L2	1.2mH (100T: 7T) Litz Wire or USTC	EI2820	-
L3, 4	3.1mH Litz Wire or USTC	EI2820	-
T1	1.2mH(35T:24T)	EE1614	-
Fuse	-	52NM250V, 3A	-
V1	430V	INR140, 431	-
Q1, 2, 3	500V, 6A	SKP6N50	FairChild
Z1	15V, 1W	-	-



# Mechanical Dimensions

## Package

Dimensions in millimeters

### 8-DIP

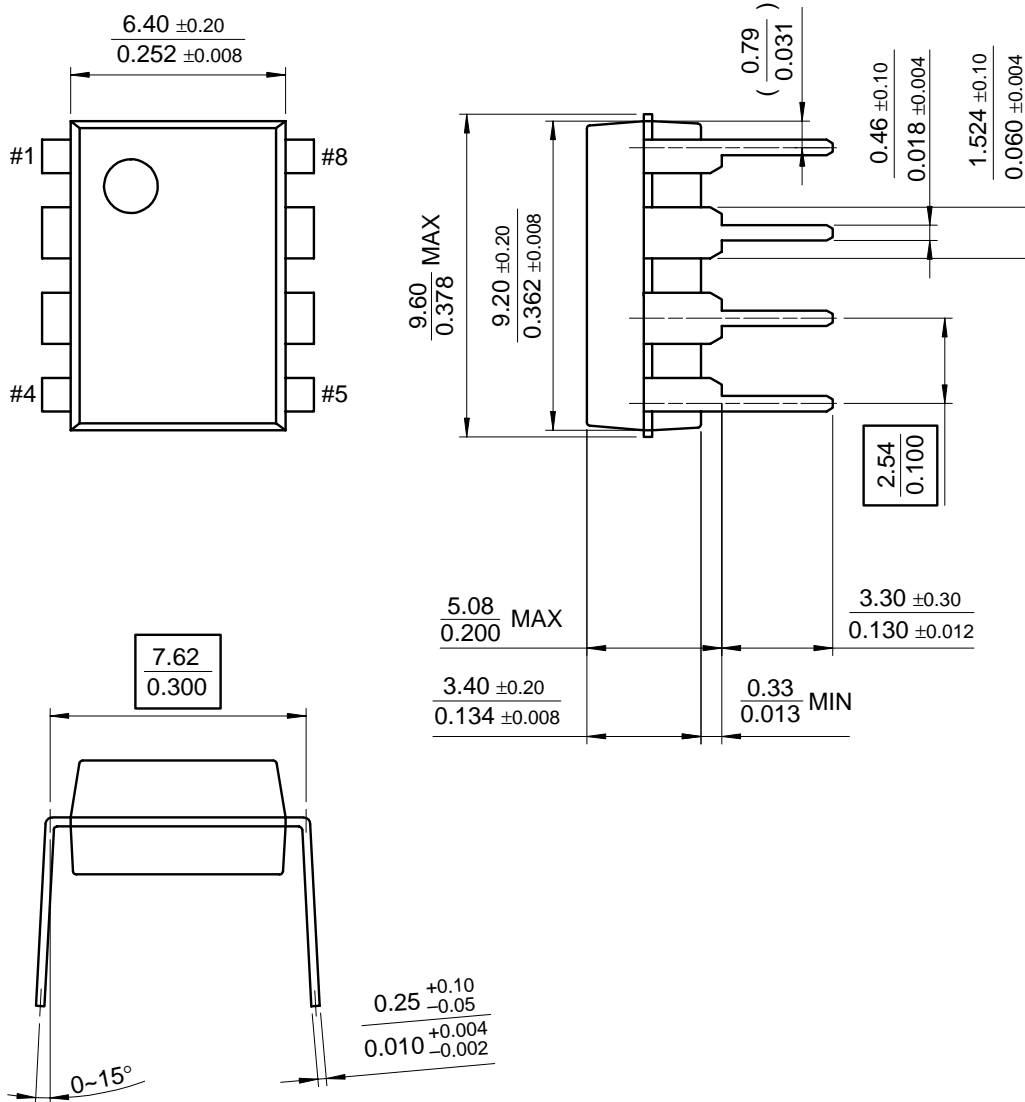

Preliminary Specification

Mechanical Dimensions (Continued)

Package

Dimensions in millimeters

8-SOP

Preliminary Specification

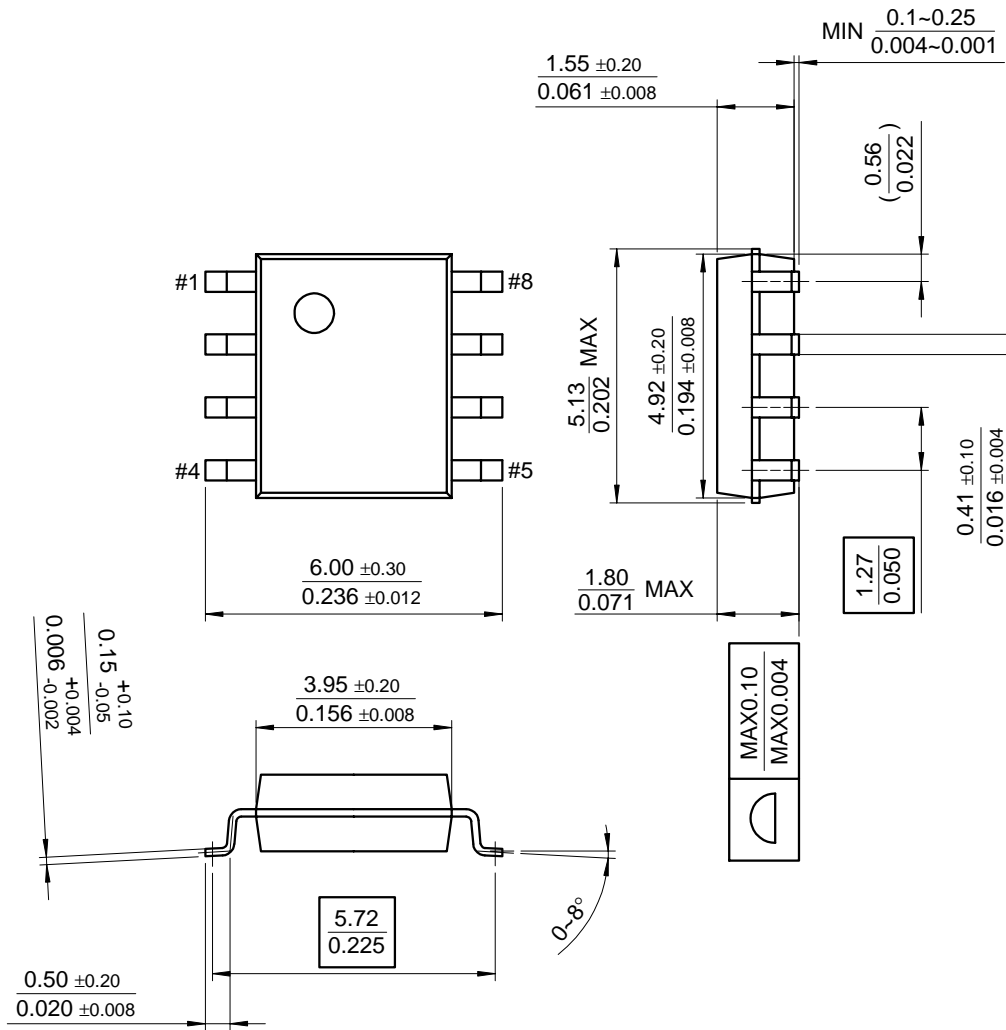

---

## Ordering Information

Product Number	Package	Operating Temperature
KA7527	8-DIP	-25 ~ +125°C
KA7527D	8-SOP	

# Preliminary Specification

## **DISCLAIMER**

FAIRCHILD SEMICONDUCTOR RESERVES THE RIGHT TO MAKE CHANGES WITHOUT FURTHER NOTICE TO ANY PRODUCTS HEREIN TO IMPROVE RELIABILITY, FUNCTION OR DESIGN. FAIRCHILD DOES NOT ASSUME ANY LIABILITY ARISING OUT OF THE APPLICATION OR USE OF ANY PRODUCT OR CIRCUIT DESCRIBED HEREIN; NEITHER DOES IT CONVEY ANY LICENSE UNDER ITS PATENT RIGHTS, NOR THE RIGHTS OF OTHERS.

## **LIFE SUPPORT POLICY**

FAIRCHILD'S PRODUCTS ARE NOT AUTHORIZED FOR USE AS CRITICAL COMPONENTS IN LIFE SUPPORT DEVICES OR SYSTEMS WITHOUT THE EXPRESS WRITTEN APPROVAL OF THE PRESIDENT OF FAIRCHILD SEMICONDUCTOR INTERNATIONAL. As used herein:

1. Life support devices or systems are devices or systems which, (a) are intended for surgical implant into the body, or (b) support or sustain life, and (c) whose failure to perform when properly used in accordance with instructions for use provided in the labeling, can be reasonably expected to result in a significant injury of the user.
2. A critical component in any component of a life support device or system whose failure to perform can be reasonably expected to cause the failure of the life support device or system, or to affect its safety or effectiveness.