

APExx16 Series

DATA SHEET

APLUS INTEGRATED CIRCUITS INC.

Address:

3 F-10, No. 32, Sec. 1, Chenggung Rd., Taipei,
Taiwan 115, R.O.C.
(115)台北市南港區成功路一段 32 號 3 樓之 10.

TEL: 886-2-2782-9266

FAX: 886-2-2782-9255

WEBSITE : <http://www.aplusinc.com.tw>

Sales E-mail:

sales@plusinc.com.tw

Technology E-mail:

service@plusinc.com.tw

1.0 General Description

The **APExx16** series are very low cost voice and melody synthesizer with 4-bits CPU. They have various features including 4-bits ALU, ROM, RAM, I/O ports, timers, clock generator, voice and melody synthesizer, and PWM (Direct drive) or D/A current outputs, etc. The audio synthesizer contains one voice-channel and two melody-channels. Furthermore, they consist of 27 instructions in these devices. With CMOS technology and halt function can minimize power dissipation. Their architectures are similar to RISC, with two stages of instruction pipeline. They allow all instructions to be executed in a single cycle, except for program branches and data table read instructions (which need two instruction cycles).

2.0 Features

- (1) Single power supply can operate from 2.4V to 5.5V at 4MHz or 8MHz.
- (2) Program ROM: 16k x 10 bits (*APE8416 /APE10616 /APE12716* are 64k x 10 bits)
- (3) 1 set of 16-bits DPR can access up to 64k x 10 bits melody data memory space, and 1 set of 19-bits VPR can access up to 512k x 10 bits voice data memory space.

Product	Voice Duration (sec)	Voice Pointer (VPR)	ROM Size (10-bits)
APE1016	10	15-bits	32k
APE1516	15	16-bits	48k
APE2016	20	16-bits	64k
APE3116	31	17-bits	96k
APE4116	41	17-bits	128k
APE6316	63	18-bits	192k
APE8416	84	18-bits	256k
APE10616	106	19-bits	320k
APE12716	127	19-bits	384k

- (4) Data Registers:
 - a). 128 x 4-bits data RAM (00-7Fh)
 - b). Unbanked special function registers (SFR) range: 00h-2Fh
- (5) I/O Ports:
 - a). PRA: 4-bits I/O Port A (10h) can be programmed to input/output individually. (Register control)
 - b). PRB: 4-bits I/O Port B (13h) can be configured to input/output individually. (Mask option)
 - c). PRC: 4-bits I/O Port C (14h) can be programmed to input/output individually. (Register control)
 - d). PRD: 4-bits I/O Port D (15h) can be programmed to input/output individually. (Register control)
- (6) On-chip clock generator: Resistive Clock Drive (**RM**) or Crystal oscillator (**HM**)
- (7) Timer: 1-set Voice Interrupt (Timer0: a 9-bits auto-reload timer/counter).
- (8) Stack: 2-level subroutine nesting.
- (9) Built-in 4 Level Volume Control can be programmed.

- (10) Built-in 8 Level DAC current output can be configured. (Mask option)
- (11) Built-in IR Carry Output: Port B[1] can be configured as IR pin by 38k / 56kHz. (Mask option)
- (12) External Reset: Port B[3] can be configured as reset pin. (Mask option)
- (13) HALT and Release from HALT function to reduce power consumption
- (14) Watch Dog Timer (**WDT**)
- (15) Instruction: 1-cycle instruction except for table read and program branches which are 2-cycles
- (16) Number of instruction: 27
- (17) DAC: 1 channel voice and dual tone melody synthesizer (One 9-bits Cout or 8-bits PWM output).

FIGURE 1 : ROM Map of APExx16 Series

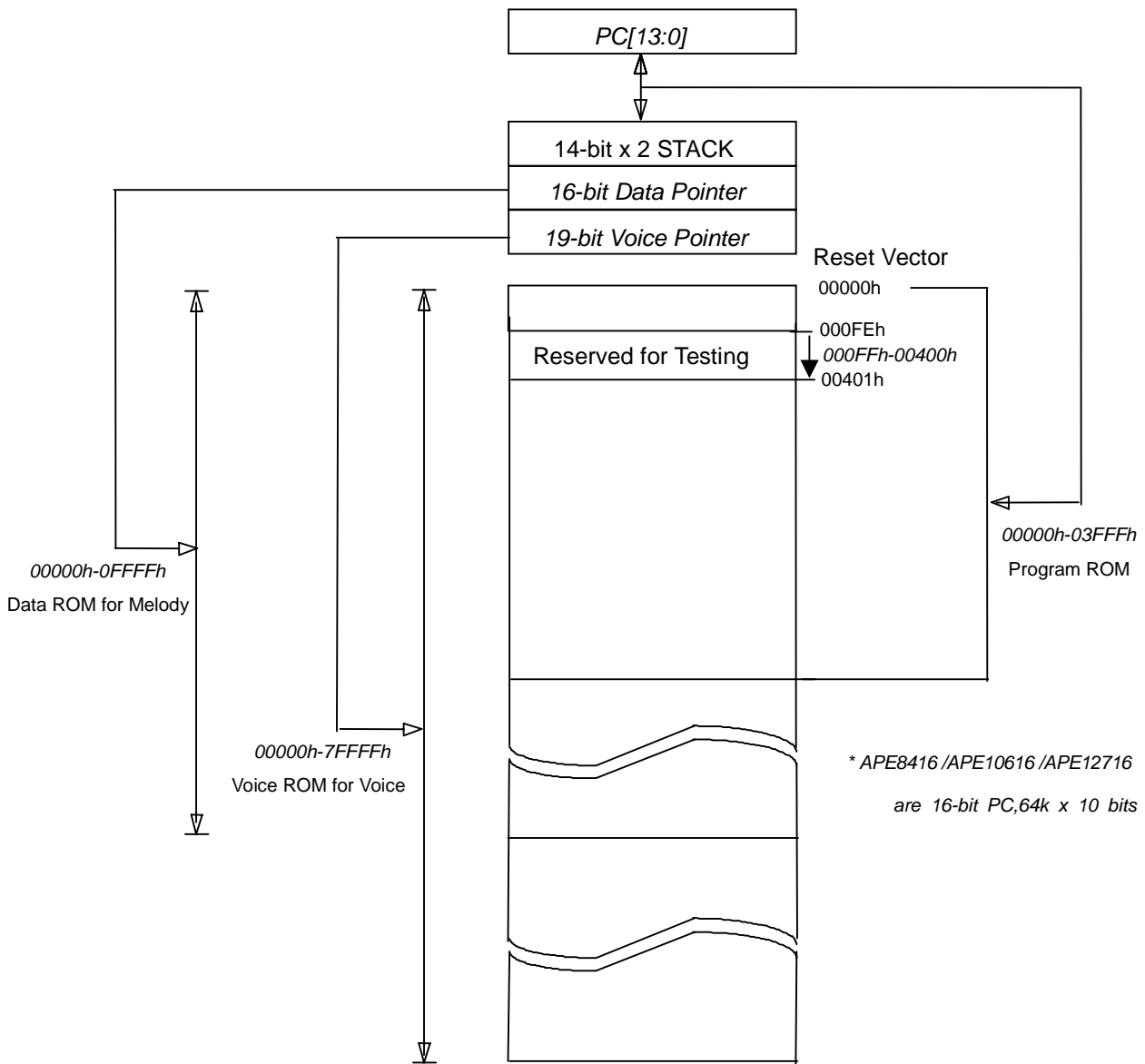

3.0 Pin Description

Pad Name	Pin Attr.	Description
PWM2/Cout	O	PWM2 output, or Current Output of Audio.
PWM1	O	PWM1 output.
Vdd1~3	Power	Power supply during operation.
PRA0~3 PRC0~3 PRD0~3	I/O	I/O port can be programmed to input/output individually. Input type with weak pull-low or fix-input-floating capability. Buffer Output type.
PRB0 / OSC2	I/O	I/O port can be configured to input/output individually or HM OSC pad. Input type with weak pull-low or fix-input-floating capability. Buffer Output type.
PRB1 / IR	I/O	I/O port can be configured to input/output individually. Input type with weak pull-low or fix-input-floating capability. Buffer Output type. <i>Mask option selected as an IR Carrier Output with 38k / 56kHz</i>
PRB2	I/O	I/O port can be configured to input/output individually. Input type with weak pull-low or fix-input-floating capability. Buffer Output type.
PRB3 / Reset	I/O	I/O port can be configured to input/output individually. Input type with weak pull-low or fix-input-floating capability. Buffer Output type. <i>Mask option selected as an external RESET pin with weak pull-low capability.</i>
OSC1	I	RM/HM mode Oscillator input
GND1~4	Power	Ground Potential

4.0 DC Characteristics

Symbol	Parameter	Vdd	Min.	Typ.	Max.	Unit	Condition
Vdd	Operating voltage		2.4	3	5.5	V	depending on Freq.
Isb	Supply current	Standby	3		1	uA	4MHz, RM, in HALT Mode
			4.5		1		
Iop	Supply current	Operating	3	1		mA	4MHz, RM, IO Floating
			4.5	2.5			
Iih	Input current (Internal pull low)	3		3		uA	Input ports with weak pull-low
		4.5		10			
Ioh	Output-high current	3		-3		mA	4MHz, RM (IO ports)
		4.5		-10			
Iol	Output-low current	3		7		mA	4MHz, RM (IO ports)
		4.5		19			
Cout	DAC output current (8-level option)	3		0.8 ~ 4.8		mA	4MHz, RM (Full scale)
		4.5		0.9 ~ 6.5			
dF/F	Frequency stability		-5		5	%	$\frac{F_{osc}(3v-2.4v)}{F_{osc}(3v)}$
dF/F	Fosc lot variation		-10		10	%	Vdd=3V, Rosc=430k, 4MHz

FIGURE 2 : Frequency vs. Rosc (at 3V)

Resistor (Rosc ohms)	110k	200k	300k	430k
Frequency (MHz)	14.84	8.25	5.54	3.92

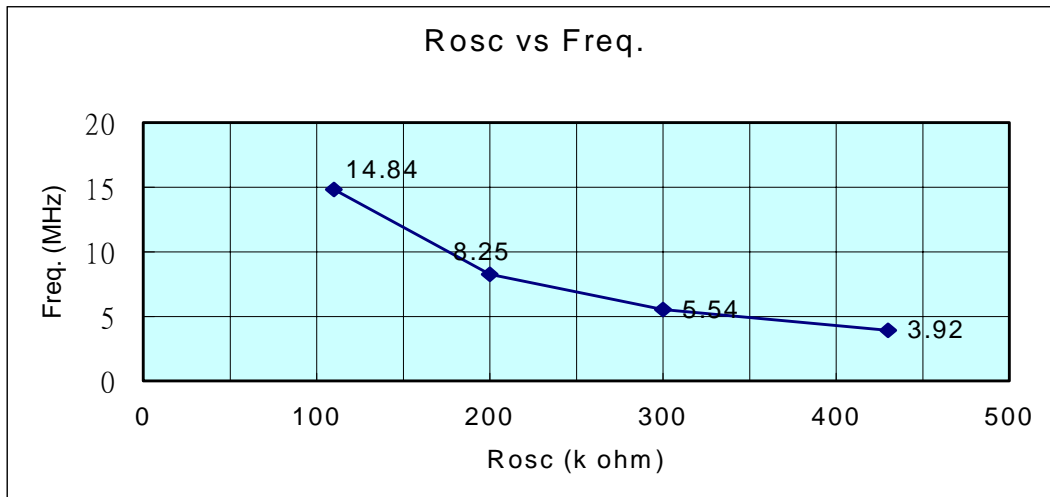

5.0 Application Circuit

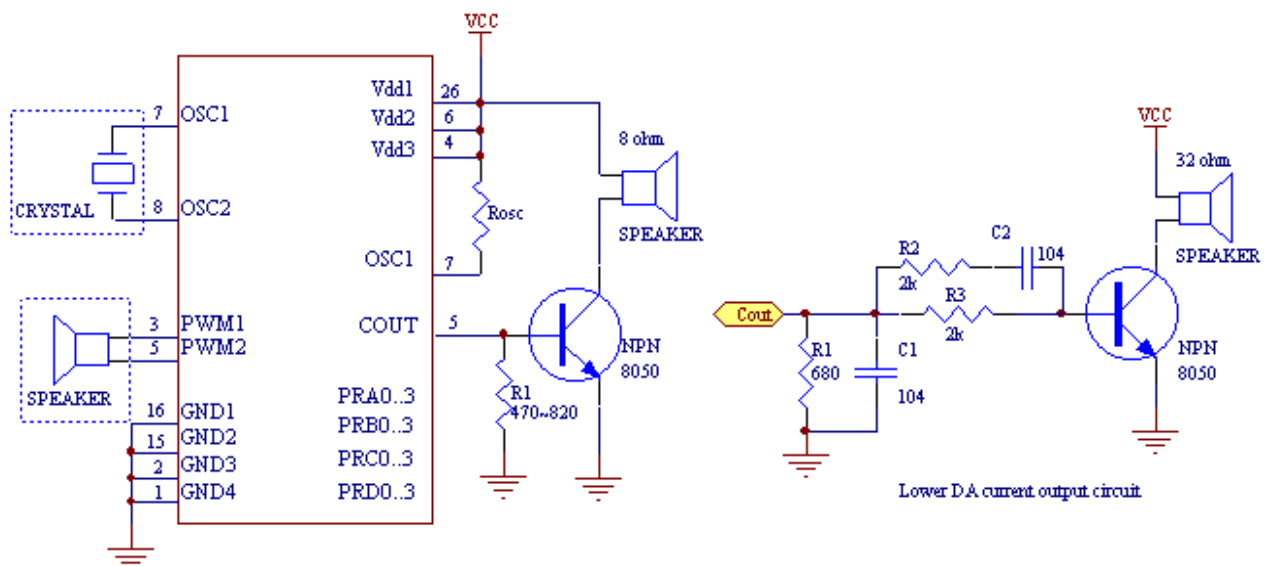

6.0 Bonding Diagram of APE1016 /APE1516 /APE2016

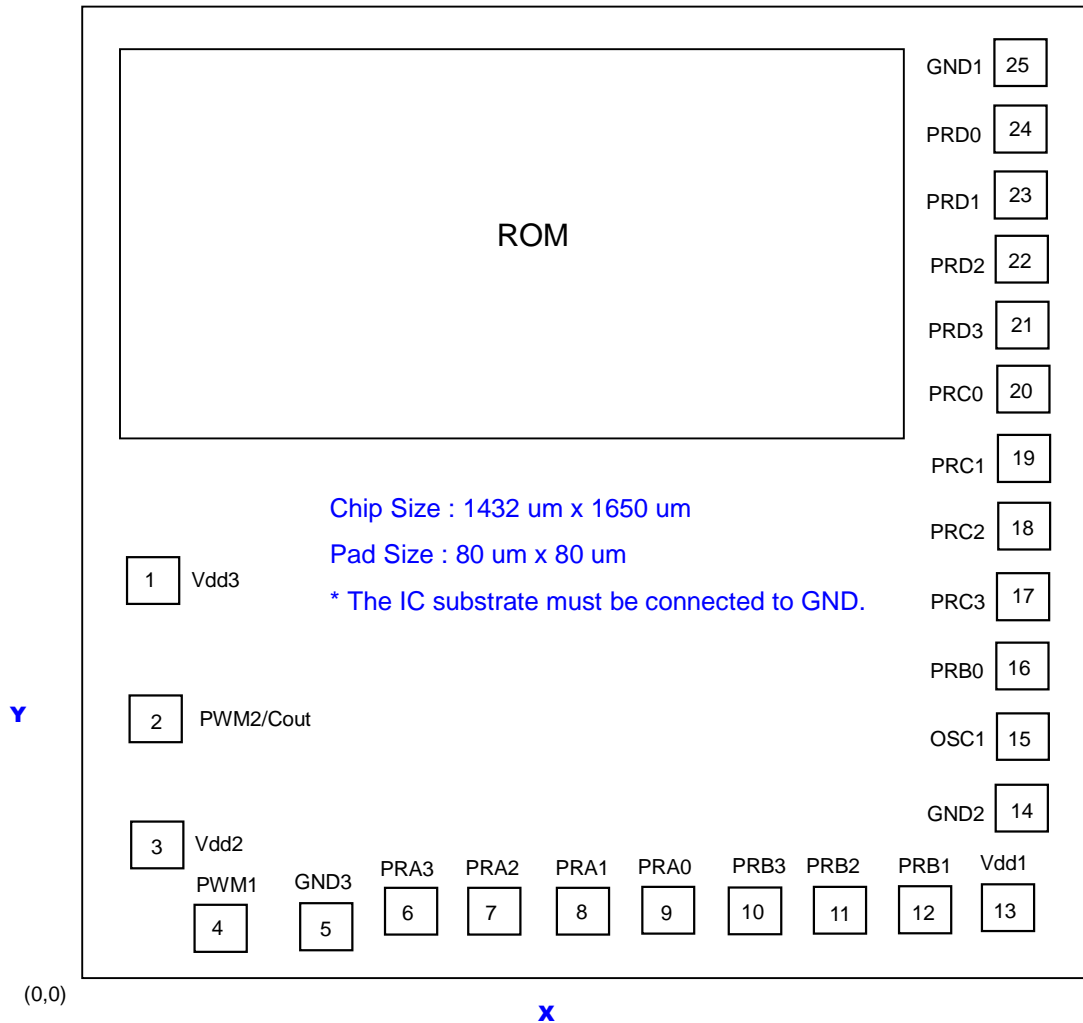

Pad #	Pad Name	X	Y	Pad #	Pad Name	X	Y
1	Vdd3	56	647	14	GND2	1261	235
2	PWM2/Cout	58	466	15	OSC1	1261	350
3	Vdd2	58	182	16	PRB0/OSC2	1261	465
4	PWM1	145	58	17	PRC3	1261	580
5	GND3	293	58	18	PRC2	1261	695
6	PRA3	413	87	19	PRC1	1261	810
7	PRA2	533	87	20	PRC0	1261	925
8	PRA1	653	87	21	PRD3	1261	1040
9	PRA0	773	87	22	PRD2	1261	1155
10	PRB3/Reset	893	87	23	PRD1	1261	1270
11	PRB2	1013	87	24	PRD0	1261	1385
12	PRB1/IR	1133	87	25	GND1	1261	1500
13	Vdd1	1253	87				

6.1 Bonding Diagram of APE3116 /APE4116 /APE6316

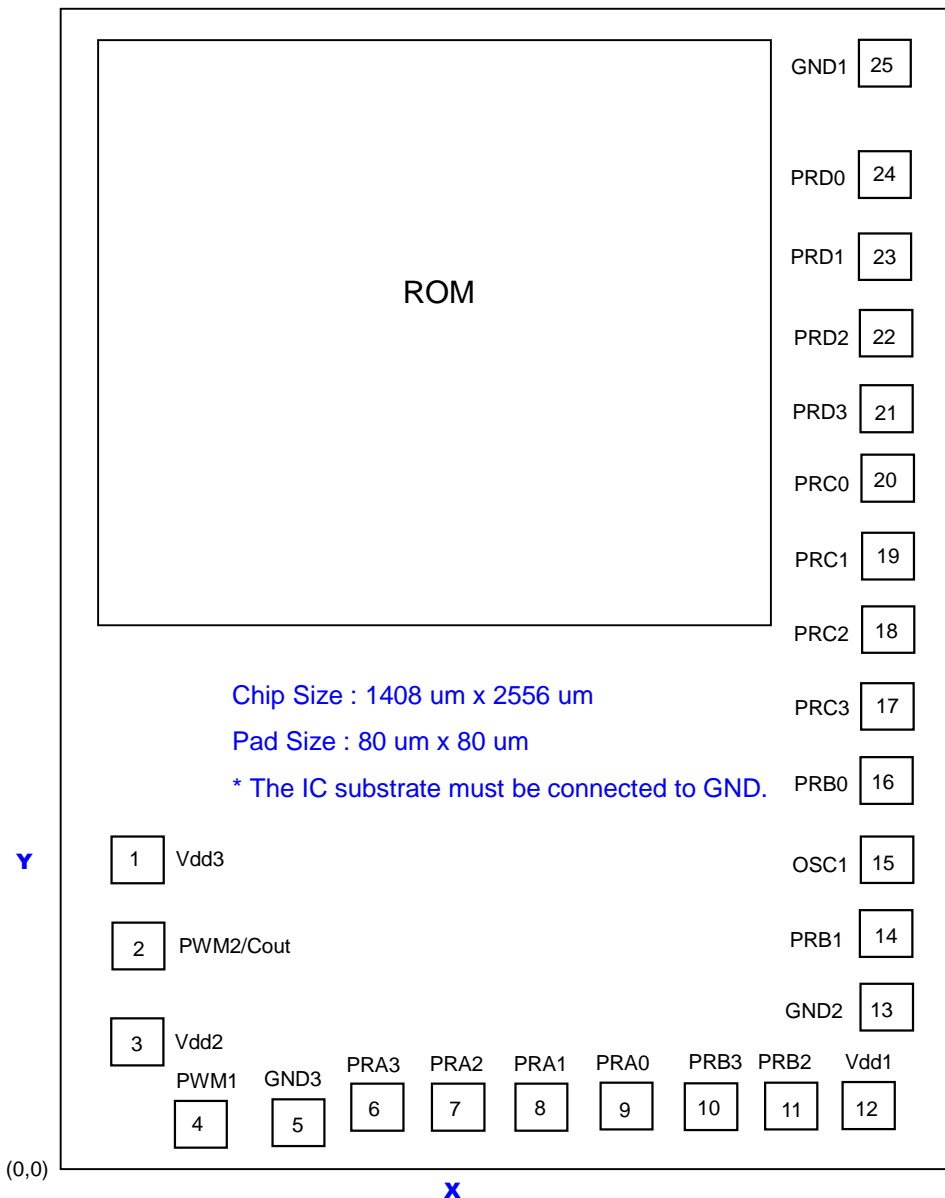

Pad #	Pad Name	X	Y	Pad #	Pad Name	X	Y
1	Vdd3	56	647	14	PRB1/IR	1248	407
2	PWM2/Cout	58	466	15	OSC1	1248	569
3	Vdd2	58	182	16	PRB0/OSC2	1248	735
4	PWM1	145	58	17	PRC3	1248	900
5	GND3	293	58	18	PRC2	1248	1062
6	PRA3	430	87	19	PRC1	1248	1224
7	PRA2	563	87	20	PRC0	1248	1386
8	PRA1	696	87	21	PRD3	1248	1548
9	PRA0	829	87	22	PRD2	1248	1710
10	PRB3/Reset	962	87	23	PRD1	1248	1872
11	PRB2	1095	87	24	PRD0	1248	2034
12	Vdd1	1228	87	25	GND1	1248	2309
13	GND2	1248	272				

6.2 Bonding Diagram of APE8416 /APE10616 /APE12716

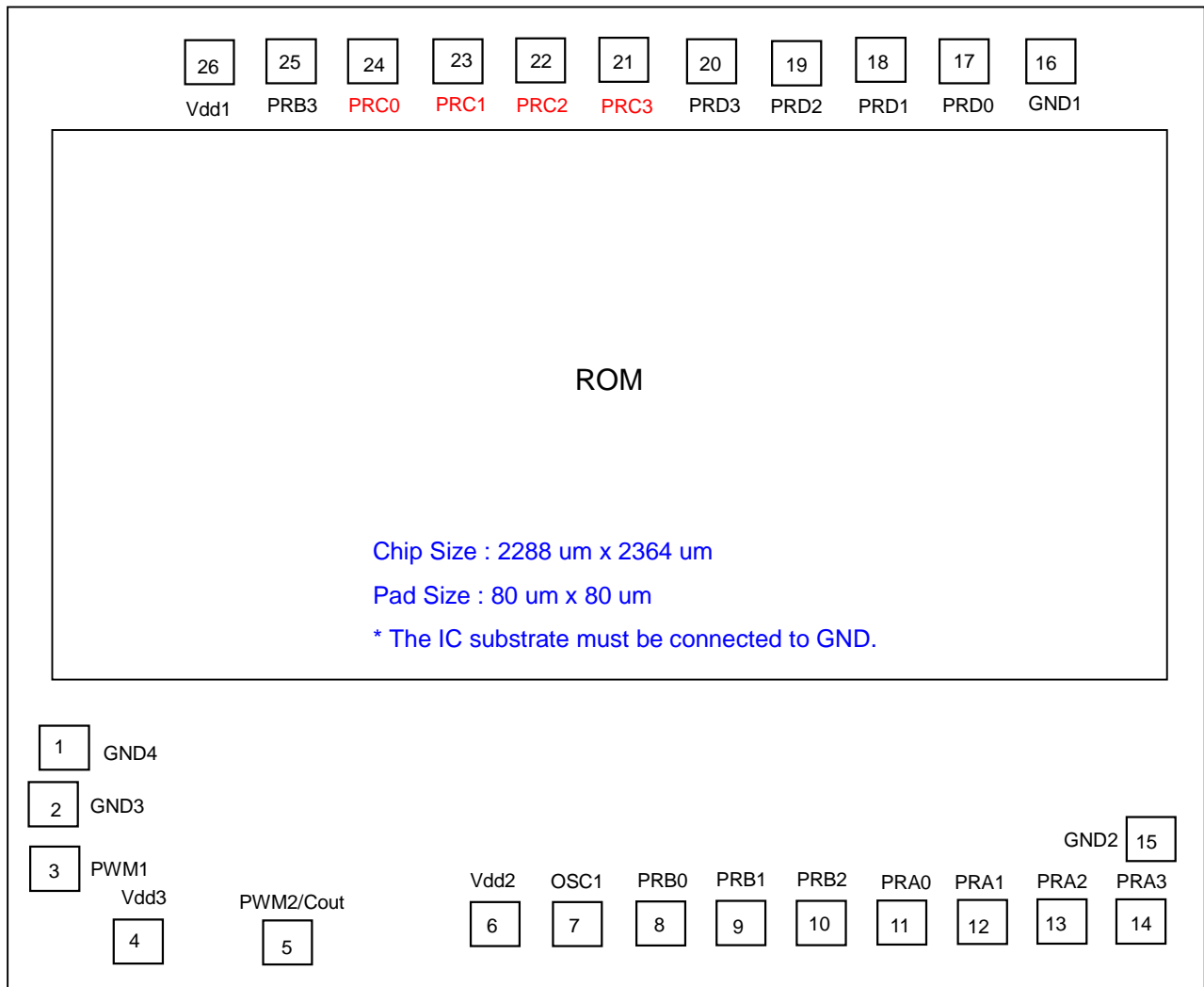

(0,0)

X

Pad #	Pad Name	X	Y	Pad #	Pad Name	X	Y
1	GND4	76	404	14	PRA3	2109	76
2	GND3	59	294	15	GND2	2128	212
3	PWM1	59	146	16	GND1	1927	2204
4	Vdd3	183	59	17	PRD0	1765	2204
5	PWM2/Cout	467	59	18	PRD1	1603	2204
6	Vdd2	815	76	19	PRD2	1441	2204
7	OSC1	976	76	20	PRD3	1279	2204
8	PRB0/OSC2	1140	76	21	PRC3	1117	2204
9	PRB1/IR	1304	76	22	PRC2	955	2204
10	PRB2	1465	76	23	PRC1	793	2204
11	PRA0	1626	76	24	PRC0	631	2204
12	PRA1	1787	76	25	PRB3/Reset	469	2204
13	PRA2	1948	76	26	Vdd1	307	2204