

Accessories

- > Standard Mounting Pads
- > Standard Clips
- > Alignment Pads
- > Stanchion Pads
- > Mounting Kits
- > Card Ejectors
- > Insulating Shoulder Washers

- > Request a Sample
- > Request a Quote
- > Ask an Engineer

Shoulder Washers

RoHS Compliant

40% glass filled polyphenylene sulfide (PPS).
Chemically inert [no known solvents under 200°C (392°F)]
Maximum recommended service temperature of 260°C (500°F)
Recommended torque is 0.565Nm to 0.678Nm (5 to 6 inch-pounds) on all shoulder washers except -7, which has recommended torque of 0.452Nm (4 inch-pounds).

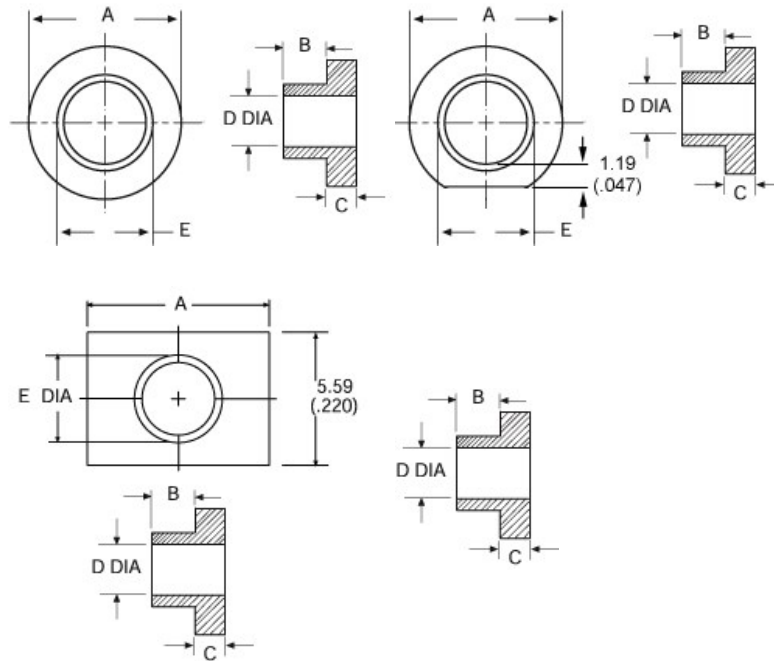

Polyphenylene Sulfide PPS Shoulder Washers

Note: A single gate extension, not to exceed 0.64mm (0.025") in length, is allowable on the outside of all shoulder washers.





Model	A	B	C	D	E	Fig	Buy
7721-1PPSG	7.11 (0.280)	3.18 (0.125)	1.07 (0.042)	2.84 (0.112)	3.81 (0.150)	1	
7721-3PPSG	7.11 (0.280)	3.18 (0.125)	1.07 (0.042)	2.84 (0.112)	3.56 (0.140)	1	
7721-4PPSG	7.92 (0.312)	.79 (0.081)	1.19 (0.047)	3.71 (0.146)	4.83 (0.190)	1	
7721-5PPSG	7.92 (0.312)	.79 (0.031)	1.19 (0.047)	3.66 (0.144)	4.50 (0.177)	1	
7721-6PPSG	7.11 (0.280)	.79 (0.031)	1.19 (0.047)	3.00 (0.118)	3.68 (0.145)	1	
7721-7PPSG*	5.46 (0.215)	.81 (0.032)	1.02 (0.040)	2.95 (0.116)	3.53+0.00 -0.10 (0.139)	1	
7721-8PPSG	6.22 (0.245)	1.02 (0.040)	1.02 (0.040)	3.02 (0.119)	3.56 (0.140)	2	

7721-9PPSG	7.62 (0.300)	1.22 (0.048)	1.40 (0.055)	2.97 (0.117)	3.56 (0.140)	3	
7721-10PPSG	7.62 (0.300)	2.41 (0.095)	1.40 (0.055)	2.97 (0.117)	3.56 (0.140)	3	

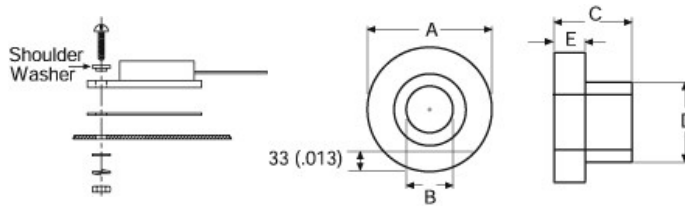
Nylon Shoulder Washers

RoHS Compliant



Model	A	B	C	D	E	Buy
7721-11NG Formerly Motorola p/n B51547F003	7.80 / 8.05 (0.307 / 0.317)	2.87 / 3.00 (0.113 / 0.118)	3.56 / 3.81 (0.140 / 0.150)	3.76 / 3.89 (1.48 / 1.53)	1.09 / 1.35 (0.043 / 0.053)	
7721-12N Formerly Motorola p/n B51547F005	9.40 / 9.65 (0.370 / .380)	3.84 / 4.09 (0.151 / .161)	2.16 / 2.41 (0.085 / .095)	6.10 / 6.35 (0.240 / .250)	1.02 / 1.27 (0.040 / .050)	
7721-13NG Formerly Motorola p/n B51547F011	5.89 / 6.05 (0.232 / 0.238)	2.87 / 3.00 (0.113 / 0.118)	4.11 / 4.45 (0.162 / 0.175)	3.43 / 3.56 (0.135 / 0.140)	1.19 / 1.40 (0.047 / 0.055)	
7721-14N Formerly Motorola p/n B51547F018	6.40 / 6.60 (0.252 / .260)	2.90 / 3.10 (0.114 / .122)	2.69 / 2.90 (0.106 / .114)	3.89 / 4.09 (0.153 / .161)		
7721-15NG Formerly Motorola p/n B51547F019	5.59 / 6.10 (0.220 / 0.240)	2.90 / 2.95 (0.114 / 0.116)	1.73 / 1.91 (0.068 / 0.075)	3.43 / 3.58 (0.135 / 0.141)	.51 / 0.64 (0.020 / 0.025)	

Customer Assistance

- Contact Us
- Find a Distributor
- Find a Sales Rep
- Request a Quote
- Get Design Assistance
- Terms and Conditions
- Returns

Popular Products

- Fan Heat Sinks
- Extrusions
- Board Level
- Liquid Cooling
- Heat Pipe Technology
- Heat Sink Accessories
- Interface Materials

Our Company

- News and Events
- Management Team
- Worldwide Locations
- Disclaimer
- Customer Survey
- Privacy Policy
- Careers

Connect with Aavid

Like / Follow / Connect



© Copyright 2017 Aavid Thermalloy, LLC.

USA: 1.855.32.AAVID Europe: 39.051.764002 Asia: 86.21.6115.2000 x 8122