

CD4014BM/CD4014BC 8-Stage Static Shift Register

General Description

The CD4014BM/CD4014BC is an 8-stage parallel input/serial output shift register. A parallel/serial control input enables individual JAM inputs to each of 8 stages. Q outputs are available from the sixth, seventh and eighth stages. All outputs have equal source and sink current capabilities and conform to standard "B" series output drive.

When the parallel/serial control input is in the logical "0" state, data is serially shifted into the register synchronously with the positive transition of the clock. When the parallel/serial control input is in the logical "1" state, data is jammed into each stage of the register synchronously with the positive transition of the clock.

All inputs are protected against static discharge with diodes to V_{DD} and V_{SS}.

Features

- Wide supply voltage range 3.0V to 15V
- High noise immunity 0.45 V_{DD} (typ.)
- Low power TTL compatibility Fan out of 2 driving 74L or 1 driving 74LS
- 5V-10V-15V parametric ratings
- Symmetrical output characteristics
- Maximum input leakage: 1 μA at 15V over full temperature range

Connection Diagram

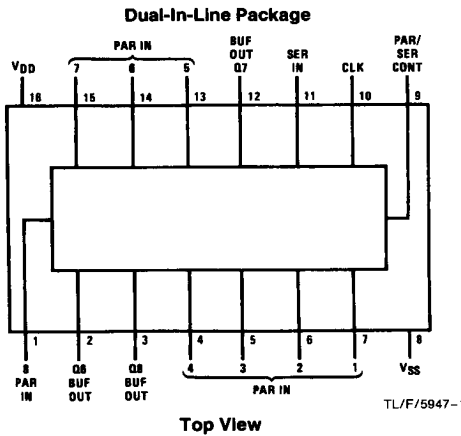

Truth Table

CL*	Serial Input	Parallel/Serial Control	PI 1	PI n	Q1 (Internal)	Qn
Level change	X	1	0	0	0	0
Level change	X	1	1	0	1	0
Level change	X	1	0	1	0	1
Level change	X	1	1	1	1	1
Level change	0	0	X	X	0	Q _{n-1}
Level change	1	0	X	X	1	Q _{n-1}
Level change	X	X	X	X	Q1	Q _n

No Change

*Level change
X = Don't care case

Order Number CD4014B*

*Please look into Section 8, Appendix D for availability of various package types.

Logic Diagram

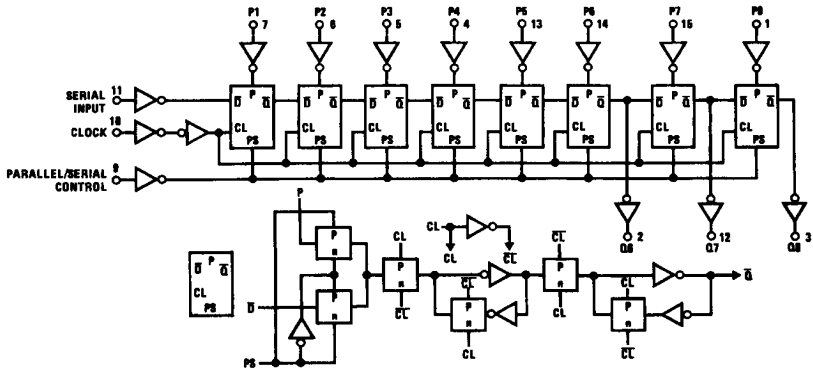

Absolute Maximum Ratings (Notes 1 & 2)

If Military/Aerospace specified devices are required, contact the National Semiconductor Sales Office/Distributors for availability and specifications.

Supply Voltage (V _{DD})	-0.5V to +18V
Input Voltage (V _{IN})	-0.5 to V _{DD} + 0.5V
Storage Temperature Range (T _S)	-65°C to +150°C
Power Dissipation (P _D)	
Dual-In-Line	700 mW
Small Outline	500 mW
Lead Temperature (T _L)	
(Soldering, 10 seconds)	260°C

Recommended Operating Conditions (Note 2)

Supply Voltage (V _{DD})	3.0V to 15V
Input Voltage (V _{IN})	0 to V _{DD}
Operating Temperature Range (T _A)	
CD4014BM	-55°C to +125°C
CD4014BC	-40°C to +85°C

DC Electrical Characteristics CD4014BM (Note 2)

Symbol	Parameter	Conditions	-55°C		+25°C			+125°C		Units
			Min	Max	Min	Typ	Max	Min	Max	
I _{DD}	Quiescent Device Current	V _{DD} = 5V, V _{IN} = V _{DD} or V _{SS} V _{DD} = 10V, V _{IN} = V _{DD} or V _{SS} V _{DD} = 15V, V _{IN} = V _{DD} or V _{SS}		5 10 20		0.1 0.2 0.3	5 10 20		150 300 600	μA
V _{OL}	Low Level Output Voltage	V _{DD} = 5V } V _{DD} = 10V } I _O < 1 μA V _{DD} = 15V }		0.05 0.05 0.05		0 0 0	0.05 0.05 0.05		0.05 0.05 0.05	V
V _{OH}	High Level Output Voltage	V _{DD} = 5V } V _{DD} = 10V } I _O < 1 μA V _{DD} = 15V }	4.95 9.95 14.95		4.95 9.95 14.95	5 10 15		4.95 9.95 14.95		V
V _{IL}	Low Level Input Voltage	V _{DD} = 5V, V _O = 0.5V or 4.5V V _{DD} = 10V, V _O = 1.0V or 9.0V V _{DD} = 15V, V _O = 1.5V or 13.5V		1.5 3.0 4.0		2 4 6	1.5 3.0 4.0		1.5 3.0 4.0	V
V _{IH}	High Level Input Voltage	V _{DD} = 5V, V _O = 0.5V or 4.5V V _{DD} = 10V, V _O = 1.0V or 9.0V V _{DD} = 15V, V _O = 1.5V or 13.5V	3.5 7.0 11.0		3.5 7.0 11.0	3 6 9		3.5 7.0 11.0		V
I _{OL}	Low Level Output Current (Note 3)	V _{DD} = 5V, V _O = 0.4V V _{DD} = 10V, V _O = 0.5V V _{DD} = 15V, V _O = 1.5V	0.64 1.6 4.2		0.51 1.3 3.4	0.88 2.2 8		0.36 0.9 2.4		mA
I _{OH}	High Level Output Current (Note 3)	V _{DD} = 5V, V _O = 4.6V V _{DD} = 10V, V _O = 9.5V V _{DD} = 15V, V _O = 13.5V	-0.64 -1.6 -4.2		-0.51 -1.3 -3.4	-0.88 -2.2 -8		-0.36 -0.9 -2.4		mA
I _{IN}	Input Current	V _{DD} = 15V, V _{IN} = 0V V _{DD} = 15V, V _{IN} = 15V		-0.10 0.10		-10 ⁻⁵ 10 ⁻⁵	-0.10 0.10		-1.0 1.0	μA

DC Electrical Characteristics CD4014BC (Note 2)

Symbol	Parameter	Conditions	-40°C		+25°C			+85°C		Units
			Min	Max	Min	Typ	Max	Min	Max	
I _{DD}	Quiescent Device Current	V _{DD} = 5V, V _{IN} = V _{DD} or V _{SS} V _{DD} = 10V, V _{IN} = V _{DD} or V _{SS} V _{DD} = 15V, V _{IN} = V _{DD} or V _{SS}		20 40 80		0.1 0.2 0.3	20 40 80		150 300 600	μA
V _{OL}	Low Level Output Voltage	V _{DD} = 5V } V _{DD} = 10V } I _O < 1 μA V _{DD} = 15V }		0.05 0.05 0.05		0 0 0	0.05 0.05 0.05		0.05 0.05 0.05	V
V _{OH}	High Level Output Voltage	V _{DD} = 5V } V _{DD} = 10V } I _O < 1 μA V _{DD} = 15V }	4.95 9.95 14.95		4.95 9.95 14.95	5 10 15		4.95 9.95 14.95		V
V _{IL}	Low Level Input Voltage	V _{DD} = 5V, V _O = 0.5V or 4.5V V _{DD} = 10V, V _O = 1.0V or 9.0V V _{DD} = 15V, V _O = 1.5V or 13.5V		1.5 3.0 4.0		2 4 6	1.5 3.0 4.0		1.5 3.0 4.0	V
V _{IH}	High Level Input Voltage	V _{DD} = 5V, V _O = 0.5V or 4.5V V _{DD} = 10V, V _O = 1.0V or 9.0V V _{DD} = 15V, V _O = 1.5V or 13.5V	3.5 7.0 11.0		3.5 7.0 11.0	3 6 9		3.5 7.0 11.0		V
I _{OL}	Low Level Output Current (Note 3)	V _{DD} = 5V, V _O = 0.4V V _{DD} = 10V, V _O = 0.5V V _{DD} = 15V, V _O = 1.5V	0.52 1.3 3.6		0.44 1.1 3.0	0.88 2.2 8		0.36 0.9 2.4		mA

DC Electrical Characteristics CD4014BC (Note 2) (Continued)

Symbol	Parameter	Conditions	-40°C		+25°C			+85°C		Units
			Min	Max	Min	Typ	Max	Min	Max	
I _{OH}	High Level Output Current (Note 3)	V _{DD} = 5V, V _O = 4.6V	-0.52		-0.44	-0.88		-0.36		mA
		V _{DD} = 10V, V _O = 9.5V	-1.3		-1.1	-2.2		-0.90		
		V _{DD} = 15V, V _O = 13.5V	-3.6		-3.0	-8		-2.4		
I _{IN}	Input Current	V _{DD} = 15V, V _{IN} = 0V		-0.3		-10 ⁻⁵	-0.3		-1.0	μA
		V _{DD} = 15V, V _{IN} = 15V		0.3		10 ⁻⁵	0.3		1.0	

AC Electrical Characteristics* T_A = 25°C, input t_r, t_f = 20 ns, C_L = 50 pF, R_L = 200 kΩ

Symbol	Parameter	Conditions	Min	Typ	Max	Units
t _{PHL} , t _{PLH}	Propagation Delay Time	V _{DD} = 5V		200	320	ns
		V _{DD} = 10V		80	160	ns
		V _{DD} = 15V		60	120	ns
t _{THL} , t _{TLH}	Transition Time	V _{DD} = 5V		100	200	ns
		V _{DD} = 10V		50	100	ns
		V _{DD} = 15V		40	80	ns
f _{CL}	Maximum Clock Input Frequency	V _{DD} = 5V	2.8	4		MHz
		V _{DD} = 10V	6	12		MHz
		V _{DD} = 15V	8	16		MHz
t _w	Minimum Clock Pulse Width	V _{DD} = 5V		90	180	ns
		V _{DD} = 10V		40	80	ns
		V _{DD} = 15V		25	50	ns
t _{rCL} , t _{fCL}	Clock Rise and Fall Time (Note 4)	V _{DD} = 5V			15	μs
		V _{DD} = 10V			15	μs
		V _{DD} = 15V			15	μs
t _S	Minimum Set-Up Time (Note 6) Serial Input t _H ≥ 200 ns	V _{DD} = 5V		60	120	ns
		V _{DD} = 10V		40	80	ns
		V _{DD} = 15V		30	60	ns
	Parallel Inputs t _H ≥ 200 ns	V _{DD} = 5V		80	160	ns
		V _{DD} = 10V		40	80	ns
		V _{DD} = 15V		30	60	ns
Parallel/Serial Control t _H ≥ 200 ns	V _{DD} = 5V		100	200	ns	
	V _{DD} = 10V		50	100	ns	
	V _{DD} = 15V		40	80	ns	
t _H	Minimum Hold Time Serial In, Parallel In, t _S ≥ 400 ns Parallel/Serial Control	V _{DD} = 5V			0	ns
		V _{DD} = 10V			10	ns
		V _{DD} = 15V			15	ns
C _i	Average Input Capacitance (Note 5)	Any Input		5	7.5	pF
C _{PD}	Power Dissipation Capacitance (Note 5)			110		pF

*AC Parameters are guaranteed by DC correlated testing.

Note 1: "Absolute Maximum Ratings" are those values beyond which the safety of the device cannot be guaranteed. Except for "Operating Temperature Range" they are not meant to imply that the devices should be operated at these limits. The table of "Electrical Characteristics" provides conditions for actual device operation.

Note 2: V_{SS} = 0V unless otherwise specified.

Note 3: I_{OL} and I_{OH} are tested one output at a time.

Note 4: If more than one unit is cascaded t_{rCL} should be made less than or equal to the fixed propagation delay of the output of the driving stage for the estimated capacitive load.

Note 5: C_{PD} determines the no load AC power consumption of any CMOS device. For complete explanation, see 54C/74C family characteristics application note AN-90.

Note 6: Setup times are measured with reference to clock and a fixed hold time (t_H) as specified.

Typical Performance Characteristics

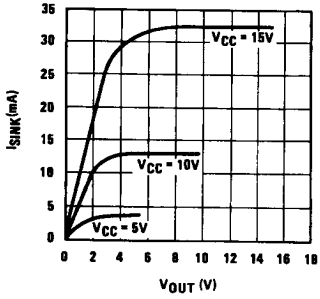

TL/F/5947-3

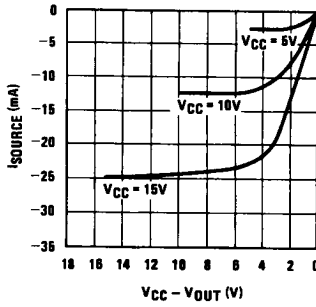

TL/F/5947-4

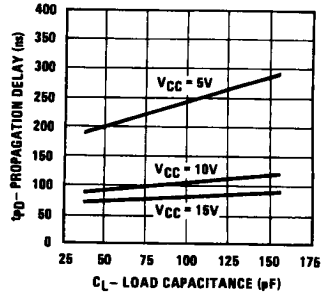

TL/F/5947-5