

TC74ACT280 9-bit Parity Generator/Checker

Features:

- **High Speed:** $f_{max} = 9.2\text{MHz}$ (typ.) at $V_{CC} = 5\text{V}$
- **Low Power Dissipation:** $I_{CC} = 8\mu\text{A}$ (max.) at $T_a = 25^\circ\text{C}$
- **Compatible with TTL Outputs:** $V_{IL} = 0.8\text{V}$ (max.); $V_{IH} = 2.0\text{V}$ (min.)
- **Symmetrical Output Impedance:** $I_{OH} = I_{OL} = 24\text{mA}$ (min.). Capability of driving 50Ω transmission lines.
- **Balanced Propagation Delays:** $t_{pLH} = t_{pHL}$
- **Pin and Function Compatible with 74F280**
- **Available in 16-pin DIP and 150 mil SOIC**

IEC Logic Symbol

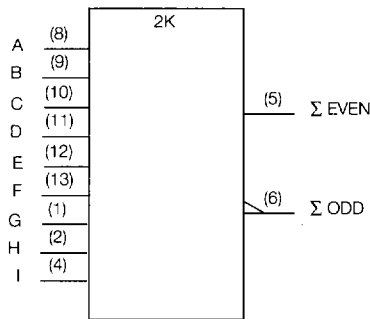

Pin Assignment

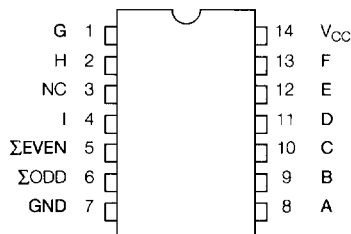

(TOP VIEW)
NC: No Connection

The TC74ACT280 is an advanced high speed CMOS 9-BIT PARITY GENERATOR fabricated with silicon gate and double-layer metal wiring C2MOS technology.

It achieves the high speed operation similar to equivalent Bipolar Schottky TTL, while maintaining the CMOS low power dissipation.

This device may be used as a level converter for interfacing TTL or NMOS to high speed CMOS. The inputs are compatible with TTL, NMOS and CMOS output voltage levels.

The TC74ACT280 is composed of nine data inputs (A thru I) and odd/even parity outputs (ΣODD and ΣEVEN).

The odd parity output is high when an odd number of data inputs are high. The even parity output is high when an even number of data inputs are high.

The word-length capability is easily expanded by cascading.

All inputs are equipped with protection circuits against static discharge or transient excess voltage.

Truth Table

NUMBER OF INPUTS A THROUGH I THAT ARE HIGH	OUTPUTS	
	ΣEVEN	ΣODD
0, 2, 4, 6, 8	H	L
1, 3, 5, 7, 9	L	H

Absolute Maximum Ratings

PARAMETER	SYMBOL	VALUE	UNIT
Supply Voltage Range	V_{CC}	-0.5-7.0	V
DC Input Voltage	V_{IN}	-0.5- $V_{CC} + 0.5$	V
DC Output Voltage	V_{OUT}	-0.5- $V_{CC} + 0.5$	V
Input Diode Current	I_{IK}	± 20	mA
Output Diode Current	I_{OK}	± 50	mA
DC Output Current	I_{OUT}	± 50	mA
DC V_{CC} /Ground Current	I_{CC}	± 100	mA
Power Dissipation	P_D	500 (DIP) */180 (SOP)	mW
Storage Temperature	T_{stg}	-65-150	°C
Lead Temperature 10sec	T_L	300	°C

* 500mW in the range of $T_a = -40^{\circ}\text{C}$ - 65°C .
From $T_a = 65^{\circ}\text{C}$ to 85°C a derating factor of
-10mW/°C should be applied up to 300mW.

Recommended Operating Conditions

PARAMETER	SYMBOL	VALUE	UNIT
Supply Voltage	V_{CC}	4.5-5.5	V
Input Voltage	V_{IN}	0- V_{CC}	V
Output Voltage	V_{OUT}	0- V_{CC}	V
Operating Temperature	T_{opr}	-40-85	°C
Input Rise and Fall Time	dt/dv	0-10	ns/v

DC Electrical Characteristics

PARAMETER	SYMBOL	TEST CONDITION	$T_a = 25^{\circ}\text{C}$				$T_a = -40\text{--}85^{\circ}\text{C}$		UNIT	
			V_{CC}	Min.	Typ.	Max.	Min.	Max.		
High-Level Input Voltage	V_{IH}	—	4.5-5.5	2.0	—	—	2.0	—	V	
			4.5-5.5	2.0	—	—	2.0	—		
			4.5-5.5	2.0	—	—	2.0	—		
Low-Level Input Voltage	V_{IL}	—	4.5-5.5	—	—	0.8	—	0.8	V	
			4.5-5.5	—	—	0.8	—	0.8		
			4.5-5.5	—	—	0.8	—	0.8		
High-Level Output Voltage	V_{OH}	$V_{IN} = V_{IH}$ or V_{IL}	$I_{OH} = -50\mu\text{A}$	4.5	4.4	4.5	—	4.4	—	V
			$I_{OH} = -24\text{mA}$	4.5	3.94	—	—	3.80	—	
			$I_{OH} = -75\text{mA}^*$	5.5	—	—	—	3.85	—	
Low-Level Output Voltage	V_{OL}	$V_{IN} = V_{IH}$ or V_{IL}	$I_{OL} = 50\mu\text{A}$	4.5	—	0.0	0.1	—	0.1	V
			$I_{OL} = 24\text{mA}$	4.5	—	—	0.36	—	0.44	
			$I_{OL} = 75\text{mA}^*$	5.5	—	—	—	—	1.65	
Input Leakage Current	I_{IN}	$V_{IN} = V_{CC}$ or GND	5.5	—	—	± 0.1	—	± 1.0	μA	
Quiescent Supply Current	I_{CC}	$V_{IN} = V_{CC}$ or GND	5.5	—	—	8.0	—	80.0		
	ΔI_{CC}	Per input: $V_{CC} = 3.4\text{V}$ Other input: V_{CC} or GND	5.5	—	—	1.35	—	1.5	mA	

* This spec indicates the capability of driving 50Ω transmission lines.
One output should be tested at a time for a 10ms maximum duration.

System Diagram

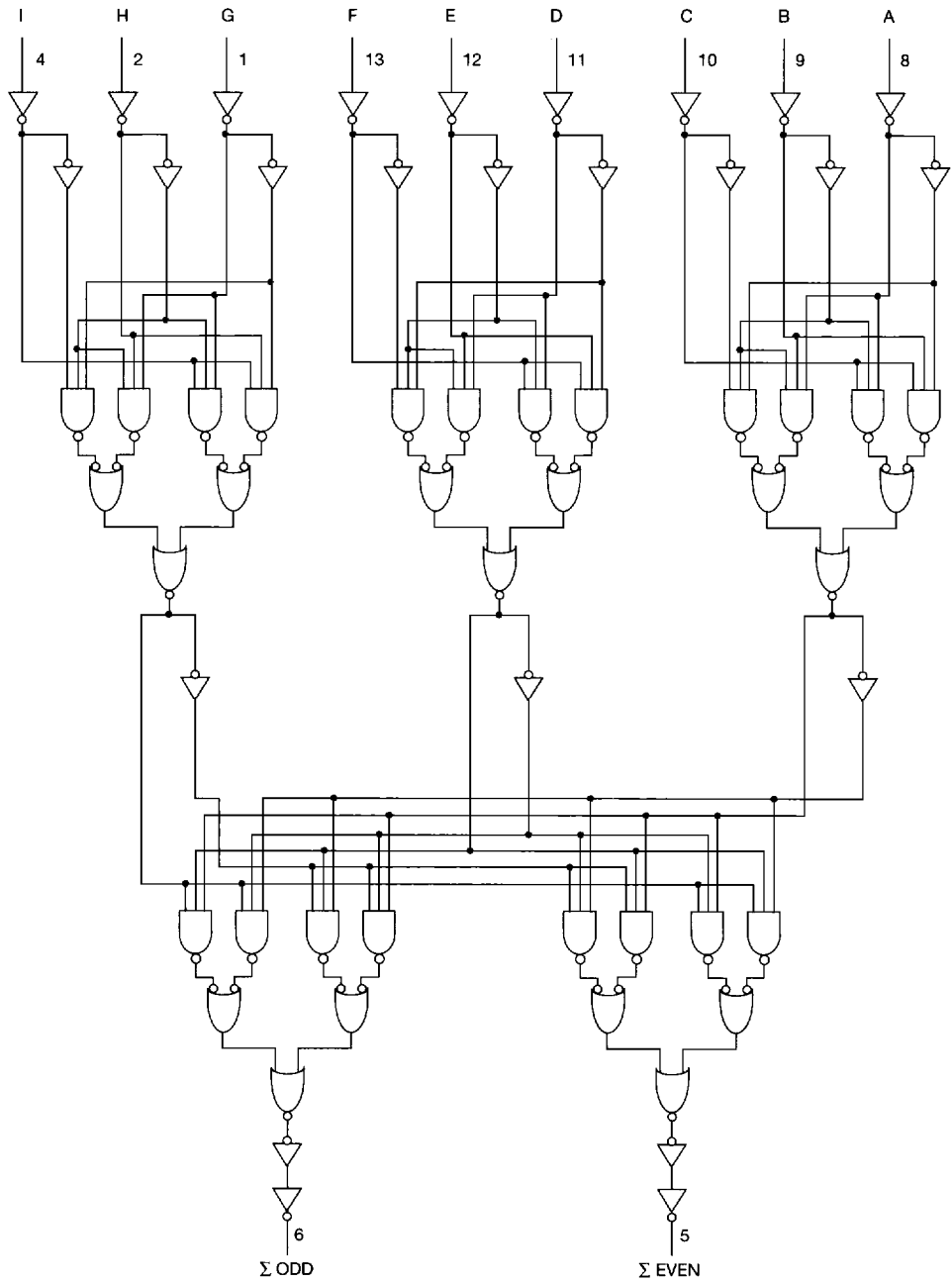

AC Electrical Characteristics ($C_L = 50\text{pF}$, $R_L = 500\Omega$, Input $t_r = t_f = 3\text{ns}$)

PARAMETER	SYMBOL	TEST CONDITION	Ta = 25°C				Ta = -40-85°C		UNIT
			V _{CC}	Min.	Typ.	Max.	Min.	Max.	
Propagation Delay Time	t_{pLH} t_{pHL}	—	5.0±0.5	—	9.9	14.5	1.0	16.5	ns
Input Capacitance	C_{IN}	—	—	—	5	10	—	10	pF
Power Dissipation Capacitance	C_{PD}^1	—	—	—	78	—	—	—	

Note (1): C_{PD} is defined as the value of the internal equivalent capacitance which is calculated from the operating current consumption without load.

Average operating current can be obtained by the equation: $I_{CC(opr)} = C_{PD} \cdot V_{CC} \cdot f_{IN} + I_{CC}$.