



# 050-337

---

## PRODUCT BRIEF

100 MBPS-5 GBPS

PRINTED CIRCUIT BOARD (PCB) MOUNT QUAD RECEIVER

850NM VCSEL COMPATIBLE RECEIVER

SMALL & COMPACT WITH RUGGED CONSTRUCTION FOR  
HARSH ENVIRONMENTS

REV	DESCRIPTION	DATE	APPROVED
2		2/5/2015	SZ

THIS COPYRIGHTED DOCUMENT IS THE PROPERTY OF GLENAIR, INC. AND IS FURNISHED ON THE CONDITION THAT IT IS NOT TO BE DISCLOSED, REPRODUCED IN WHOLE OR IN PART, OR USED TO SOLICIT QUOTATIONS FROM COMPETITIVE SOURCES, OR USED FOR MANUFACTURE BY ANYONE OTHER THAN GLENAIR, INC. WITHOUT WRITTEN PERMISSION FROM GLENAIR, INC. THE INFORMATION HEREIN HAS BEEN DEVELOPED AT GLENAIR'S EXPENSE AND MAY BE USED FOR ENGINEERING EVALUATION AND INCORPORATION INTO TECHNICAL SPECIFICATIONS AND OTHER DOCUMENTS WHICH SPECIFY PROCUREMENT OF PRODUCTS FROM GLENAIR, INC.

**050-337 Product Brief**  
**PCB Mount Quad Receiver**  
**100 Mbps – 5 Gbps, MMF, 3.3V**



**PCB Mount Fiber Optic Quad Receiver, 100M-5Gbps, MMF, 3.3V**

Glenair 050-337, is a ruggedized harsh environment PCB mount Quad Receiver with electrical and optical functionality equivalent to SFP transceivers but with mechanical design that is suited to the harsh temperature and vibration environments found in Military, Aerospace, Railway, Oil and Gas, and Industrial applications. The PCB mount quad optical receiver also supports optional Digital Monitoring Interface (DMI) features in accordance with SFF 8472. The Transceiver is comprised of four receiver sections that reside on a common package platform and interface with a host board through a high speed electrical connector.

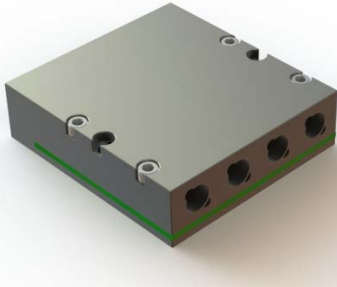

Each receiver section includes the Receiver Optical Subassembly (ROSA) and amplification/quantization circuitry. The ROSA, containing a PIN photodiode and trans-impedance preamplifier, is located at the optical interface and mates with an ARINC 801 optical connector. The ROSA is mated to a limiting amplifier IC that provides post-amplification and quantization. Also included is a Loss Of Signal (LOS) detection circuit.

**KEY FEATURES/BENEFITS**

- SFP Compatible Electrical I/O signal levels
- 850nm VCSEL lasers to support up to 5 Gbps
- PIN PD to support high sensitivity up to 5 Gbps
- Industry standard CML input and outputs that make for simple integration on customer host PCB
- ARINC 801 Optical contacts
- Easy assembly - Module is securely mounted with screws from the top to PCB to ensure excellent shock and vibration performance
- High-Speed Electrical plug-in connector eliminates the need for soldering & enables ease of servicing
- -40°C to +85°C Operating Case Temperature
- Glenair fiber jumpers connect from transceiver to any Glenair Mil/Aero Fiber Optic Connector Style
- Evaluation fixtures available
- Optional Digital Diagnostic and Monitoring (DMI) based on SFF-8472, enables monitoring of:
  - Received optical power,
  - Temperature
  - Supply voltage

**APPLICATIONS**

- Harsh Environment such as: Airborne, Tactical, Railway, Industrial, Oil and Gas and Shipboard applications
  - Ethernet, Fibrechannel, 1x, 2x, 4x, SFPDP

**HOW TO ORDER**

**Table 1 Part Number Options**

Part Number	Description
050-337-1	100Mbps-2.5Gbps,
050-337-1-D	100Mbps-2.5Gbps, with DMI Calibrated
050-337-2	2.5Gbps-5Gbps,
050-337-2-D	2.5Gbps-5Gbps, with DMI Calibrated

**050-337 Product Brief**  
**PCB Mount Quad Receiver**  
**100 Mbps – 5 Gbps, MMF, 3.3V**



**Ratings and Specifications**

**TABLE 2 ABSOLUTE MAXIMUM RATINGS**

Parameter	Symbol	Min	Typ	Max	Units	Notes
Storage Temperature	T <sub>s</sub>	-55		+100	°C	
Supply Voltage	V <sub>cc</sub>	-0.4		3.8	V	V <sub>cc</sub> may not differ by more than 0.5V

**TABLE 3 OPERATING CONDITIONS**

Parameter	Symbol	Min	Typ	Max	Units	Notes
Operating Temperature, Case	T <sub>op</sub>	-40		+85	°C	
Supply Voltage	V <sub>cc</sub>	3.135	3.3	3.465	V	
Supply Current	I <sub>cc</sub>		360	400	mA	Typical @ +85°C
Power Supply Noise (Peak-Peak)	V <sub>cc_ripple</sub>			100	mV	

**TABLE 4 ELECTRO-OPTICAL CHARACTERISTICS - RECEIVER**

Parameter	Symbol	Min	Typ	Max	Units	Notes
050-337-1						
Sensitivity, BER 10 <sup>-12</sup> , PRBS 2 <sup>7</sup> -1, Er 10 dB	P <sub>IN</sub>		-22.5	-19	dBm	PIN PD @ 1.25 Gbps
Sensitivity, BER 10 <sup>-12</sup> , PRBS 2 <sup>7</sup> -1, Er 10 dB	P <sub>IN</sub>		-22.5		dBm	PIN PD @ 2.5 Gbps
050-337-2						
Sensitivity, BER 10 <sup>-12</sup> , PRBS 2 <sup>7</sup> -1, Er 10 dB	P <sub>IN</sub>		-18.5		dBm	PIN PD @ 3.2 Gbps
Sensitivity, BER 10 <sup>-12</sup> , PRBS 2 <sup>7</sup> -1, Er 10 dB	P <sub>IN</sub>		-18		dBm	PIN PD @ 4..25Gbps
Sensitivity, BER 10 <sup>-12</sup> , PRBS 2 <sup>7</sup> -1, Er 10 dB	P <sub>IN</sub>		-17.5	-16	dBm	PIN PD @ 5 Gbps
Overload, BER 10 <sup>-12</sup> , PRBS 2 <sup>7</sup> -1	P <sub>IN</sub>	-1			dBm	@1.25Gbps or @ 5 Gbps
Optical Wavelength	λ <sub>IN</sub>	830		860	nm	
Receiver Differential Output Impedance	R <sub>out</sub>		100		Ohms	AC coupled internally
Differential Output Voltage Swing	V <sub>out_d</sub>	600		1200	mV	CML, 100 ohm
LOS Assert Level	LOS		-24	-22	dBm	@ 1.25Gbps
LOS Hysteresis	LOS <sub>HYS</sub>	1.5	2.3		dB	@ 1.25Gbps

**TABLE 5 COMPLIANCE SPECIFICATIONS**

CHARACTERISTIC	Standard	Condition	Notes
Mechanical Shock	MIL-STD-810	Para. 516.6, proc. I, 650g	0.9 ms operating
Mechanical Vibration	MIL-STD-810	Para. 514.6, 40g rms	Random, operating
ESD	MIL-STD-883		500V HBM
Flame Resistance	MIL-STD-1344	Method 1012, Cond. B	30 seconds
Damp Heat	MIL-STD-1344	Method 1002.2, Cond. B	10 cycles , 24 hours
Eye Safety	CDRH and IEC-825	Class 1 Laser Product	

**050-337 Product Brief**  
**PCB Mount Quad Receiver**  
**100 Mbps – 5 Gbps, MMF, 3.3V**



**FUNCTIONAL DESCRIPTION**

**FIGURE 2 –BLOCK DIAGRAM**

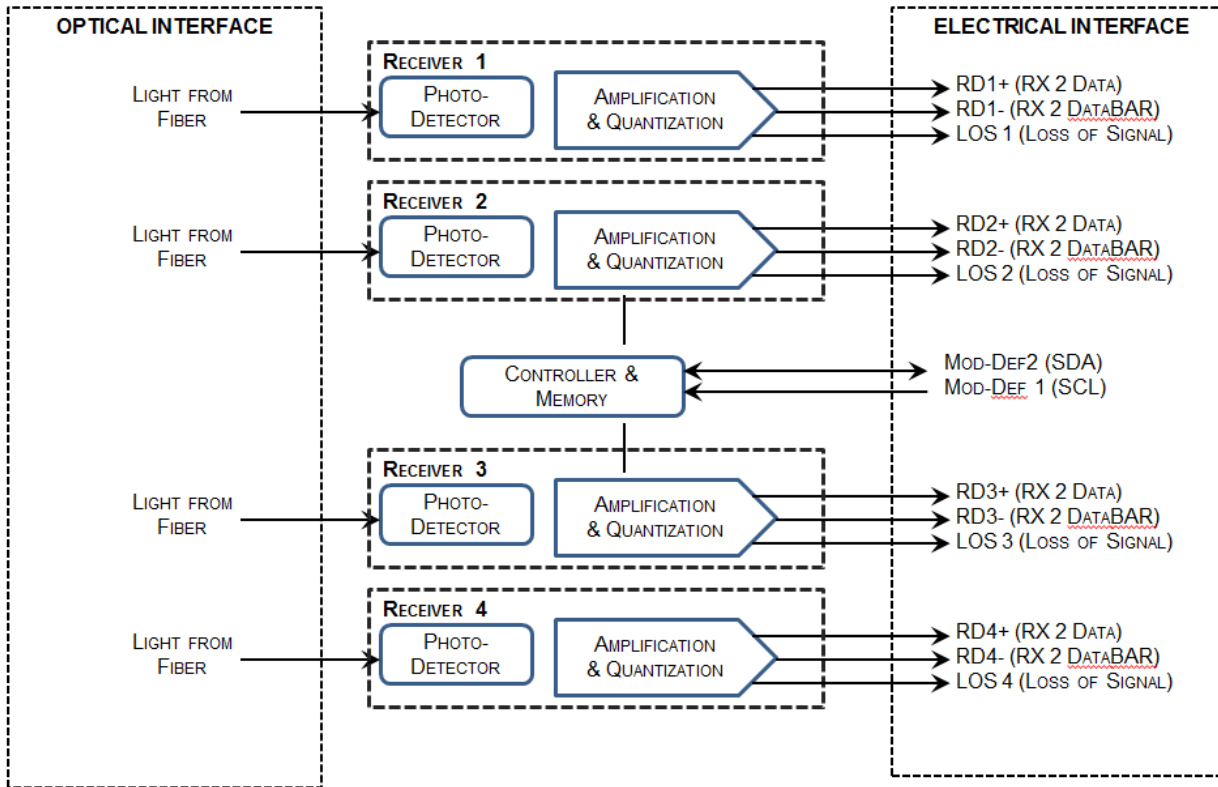

**RECEIVER SECTION**

**Receiver Loss of Signal (LOS)**

The Loss Of Signal (LOS) output indicates an unusable optical input power level. The post-amplification IC includes transition detection circuitry which monitors the ac level of incoming optical signals and provides a TTL/CMOS compatible status signal to the host. A low LOS logic level indicates the presence of an optical input while a high LOS logic level indicates an unusable optical input. The LOS thresholds are factory-set so that a high output indicates a definite optical fault has occurred (e.g. failed transmitter, broken or disconnected fiber connection to the transceiver, etc.). The LOS can also be monitored via the 2-wire serial interface (address A2h, byte 110, bit 1).

**FUNCTIONAL I/O**

The PCB mount transceiver accepts industry standard differential signals such as LVPECL and CML within the scope of the SFP MSA. To simplify board requirements, transmitter bias resistors and ac coupling capacitors are incorporated, per SFF-8074i, and hence are not required on the host board. The module is AC-coupled and internally terminated.

Figure 3 illustrates a recommended interface circuit to link the PCB mount transceiver to the supporting Physical Layer integrated circuits.

**FIGURE 3 – RECOMMENDED HOST BOARD SCHEMATIC**

**SINGLE RECEIVER SHOWN (4X RECEIVERS PER MODULE)**

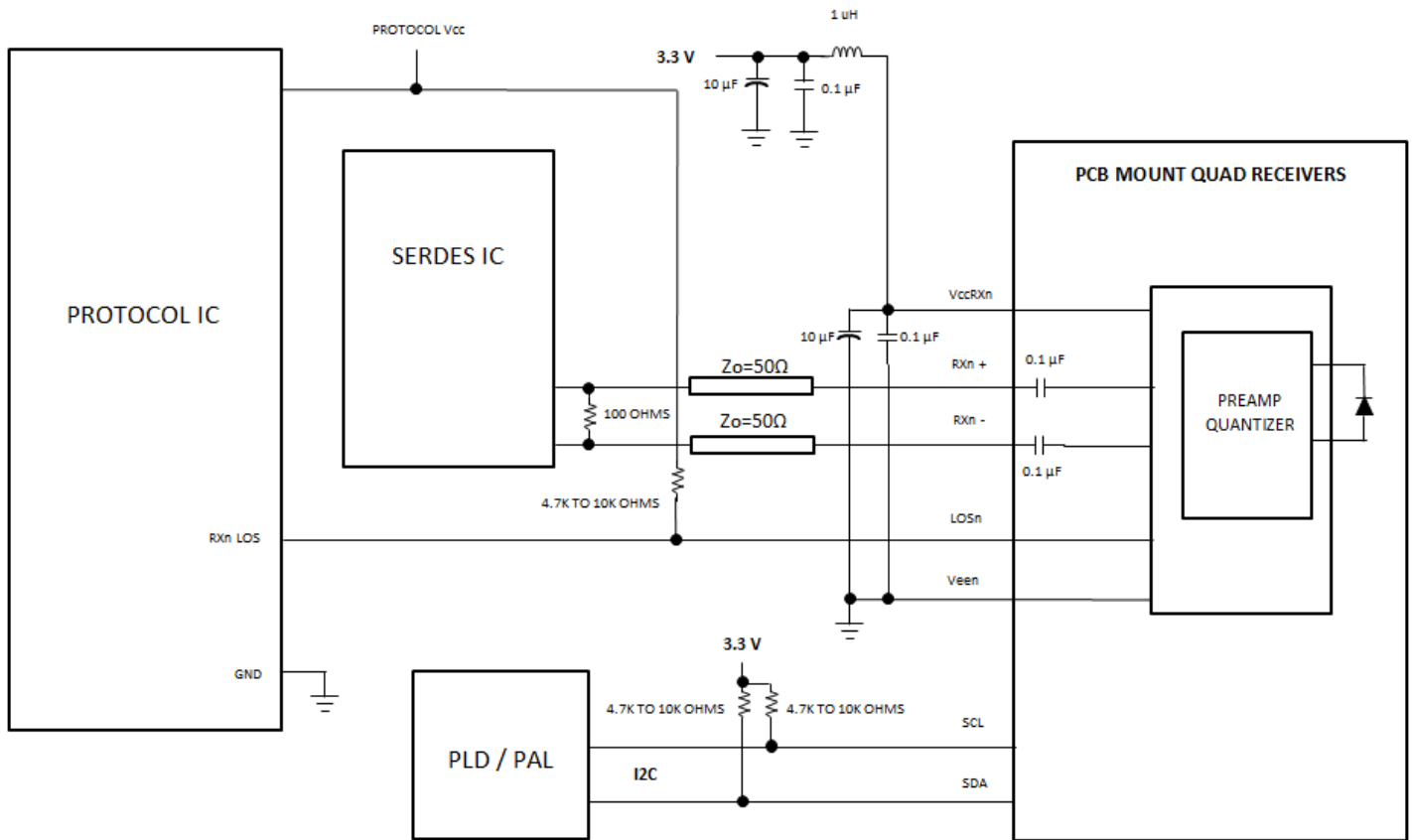

The PCB mount receiver interfaces with the host circuit board through twenty I/O pins identified by function in Table 6. The transceiver high speed transmit and receive interfaces require SFP MSA compliant signal lines on the host board. The TX Enable, TX Fault, and Rx LOS lines require TTL lines on the host board (per SFF-8074i) if used. If an application chooses not to take advantage of the functionality of these pins, RX1\_LOS, RX2\_LOS, RX3\_LOS and RX4\_LOS do not need to be connected.

**050-337 Product Brief**  
**PCB Mount Quad Receiver**  
**100 Mbps – 5 Gbps, MMF, 3.3V**



Digital Diagnostic Interface and Serial Identification (EEPROM)

The PCB mount transceiver is compatible with the SFF-8074i SFP specification and with SFF-8472, the SFP specification for Digital Diagnostic Monitoring Interface. Both specifications can be found at <http://www.sffcommittee.org>.

**FIGURE 4 – DIGITAL DIAGNOSTIC MEMORY MAP OVERVIEW**

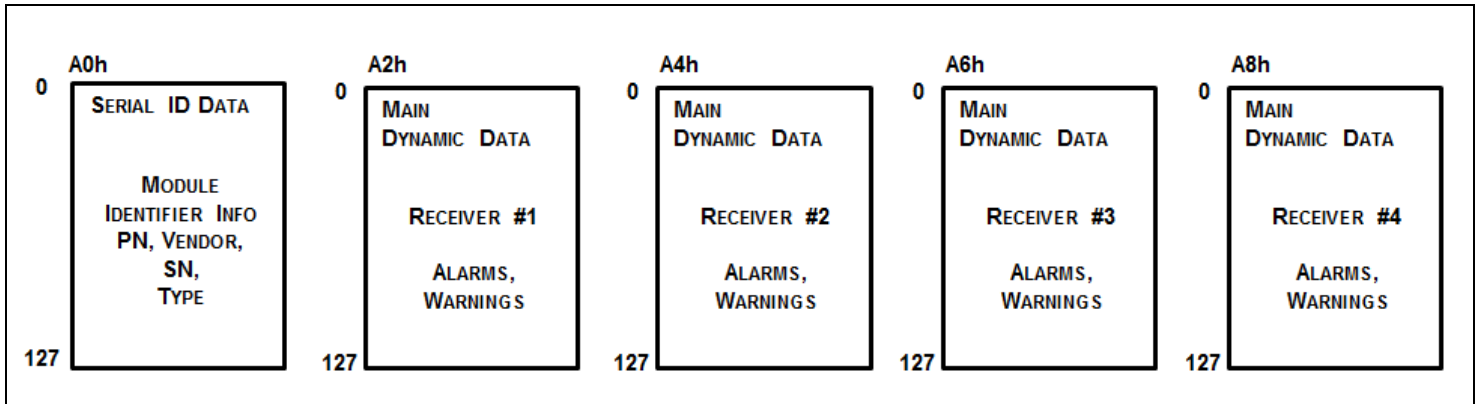

The PCB mount Quad-Receiver features EEPROM for Serial ID, which contains the product data stored for retrieval by host equipment. This data is accessed via the 2-wire serial EEPROM protocol of the ATMEL AT24C01A or similar, in compliance with the industry standard SFP Multi-Source Agreement. The base EEPROM memory, bytes 0-255 at memory address A0h, is organized in compliance with SFF-8074i.

As an enhancement to the conventional SFP interface defined in SFF-8074i, the PCB mount receiver is derived from SFF-8472 (digital diagnostic interface for optical transceivers) with Memory organized as shown in Figure 4. This digital diagnostic information is stored in bytes 0-127 at memory address A2h (RX1), A4h (RX2), A6h (RX3), A8h (RX4). Using the 2-wire serial interface defined in the MSA, the PCB mount Receiver provides real time temperature, supply voltage, and received input power for each of the four Receivers. These parameters are internally calibrated, per the SFF-8472 MSA. The digital diagnostic interface also adds the capability to monitor for Receiver Loss of Signal (RX\_LOS) for each of the 4 receivers.. The diagnostic information provides the opportunity for Predictive Failure Identification, Compliance Prediction, Fault Isolation and Component Monitoring.

Compliance Prediction

Compliance prediction is the ability to determine if an optical transceiver is operating within its operating and environmental requirements. The PCB mount receiver provide real-time access to its internal supply voltage and temperature, allowing a host to identify potential component compliance issues. Received optical power is also available to assess compliance of fiber cable plant and remote transmitter. When operating out of requirements, the link cannot guarantee error free transmission.

**050-337 Product Brief  
PCB Mount Quad Receiver  
100 Mbps – 5 Gbps, MMF, 3.3V**



Fault Isolation

The fault isolation feature allows a host to quickly pinpoint the location of a link failure, minimizing downtime. For optical links, the ability to identify a fault at a local device, remote device or cable plant is crucial to speeding service of an installation. PCB mount receiver's real-time monitors of Vcc, Temperature and Rx Power can be used to assess local receiver's current operating conditions. In addition, status flag Rx Loss of Signal (LOS) is mirrored in memory and available via the two-wire serial interface.

Component Monitoring

Component evaluation is another use of the PCB mount receiver's real-time monitors of Vcc, Temperature and Rx Power. Potential uses are as debugging aids for system installation and design, and the unit's parametric evaluation for factory or field qualification. For example, temperature per module can be observed in high density applications to facilitate thermal evaluation of systems that incorporate this PCB mount receiver.

050-337 Product Brief  
PCB Mount Quad Receiver  
100 Mbps – 5 Gbps, MMF, 3.3V



Required Host Board Components

A power supply noise rejection filter as describe in SFP MSA is required on the host PCB to meet data sheet performance. This is the same filter incorporates an inductor which should be rated 400 mADC and 1  $\Omega$  series resistance or better. It should not be replaced with a ferrite. The required filter is illustrated in Figure 5. Also, the host PCB for the PCB mount transceiver requires 4.7 K to 10 K $\Omega$  pull-up resistors for TX\_FAULT, LOS, SCA and SDL lines.

FIGURE 5 RECOMMENDED HOST BOARD POWER SUPPLY FILTERING CIRCUIT FOR EACH RECEIVER

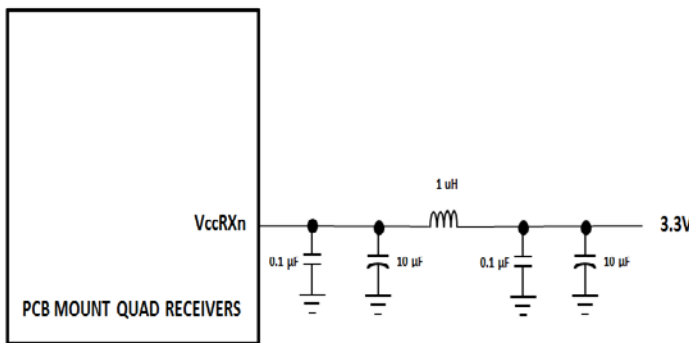

Fiber Compatibility

The transceiver is capable of transmission at 2 to 550 meters with 50/125  $\mu\text{m}$  fiber, and at 2 to 275 meters with 62.5/125  $\mu\text{m}$  fiber, for 1.25 GBd Ethernet. It is capable of transmission up to 550m with 50/125  $\mu\text{m}$  fiber and up to 300m with 62.5/125  $\mu\text{m}$  fiber, for 1.0625 GBd Fiber Channel.

Electrostatic Discharge (ESD)

The receiver is compatible with ESD levels found in typical manufacturing and operating environments as described JDEC/EIAJESD22-A114-A, Class 1 (<2000Volts) HBM. Glenair recommends that devices are handled with ESD precautions to limit exposure to below 250V HBM.

There are two design cases in which immunity to ESD damage is important. The first case is during handling of the transceiver prior to insertion to the host board. To protect the transceiver, it's important to use standard industry ESD handling precautions. These precautions include using grounded wrist straps, work benches, and floor mats in ESD controlled areas. The ESD sensitivity of the Glenair PCB mount transceiver is compatible with typical industry production environments.

The second case to consider is static discharges to the exterior of the host equipment after installation, in which case the transceiver may be subject to system-level ESD requirements.

**050-337 Product Brief**  
**PCB Mount Quad Receiver**  
**100 Mbps – 5 Gbps, MMF, 3.3V**



**TABLE 8 TWO-WIRE INTERFACE ID: DATA FIELDS – ADDRESS A0h**

Byte Decimal	# Hex	Data Notes	Byte Decimal	# Hex	Data Notes
0	80	Glenair PCB mount Transceiver	37	00	Vendor OUI (NOT USED)
1	04	Serial ID Module Definition	38	00	Vendor OUI (NOT USED)
2	80	ARINC 810 Fiber Optic Connector	39	00	Vendor OUI (NOT USED)
3	00		40	30	"0" Vendor Part Number ASCII character
4	00		41	35	"5" Vendor Part Number ASCII character
5	00		42	30	"0" Vendor Part Number ASCII character
6	01	1000BASE-SX	43	2D	"." Vendor Part Number ASCII character
7	00		44	33	"3" Vendor Part Number ASCII character
8	00		45	33	"3" Vendor Part Number ASCII character
9	00		46	37	"7" Vendor Part Number ASCII character
10	00		47	2D	"." Vendor Part Number ASCII character
11	01	Compatible with 8B/10B encoded data	48	32	"2" Vendor Part Number ASCII character
12	32	BR, 5Gbps	49	2D	"." Vendor Part Number ASCII Character
13	00		50	44	"D" Vendor Part Number ASCII Character
14	00		51	20	Note 5
15	00		52	20	" " Vendor Part Number ASCII Character
16	37	550m of 50/125mm Fiber @ 1.25Gbps	53	20	" " Vendor Part Number ASCII Character
17	1B	275 m of 62.5/125mm Fiber @ 1.25Gbps	54	20	" " Vendor Part Number ASCII Character
18	00		55	20	" " Vendor Part Number ASCII Character
19	00		56	20	" " Vendor REV Level ASCII Character
20	47	"G" Vendor NAME ASCII Character	57	20	" " Vendor REV Level ASCII Character
21	4C	"L" Vendor NAME ASCII Character	58	20	" " Vendor REV Level ASCII Character
22	45	"E" Vendor NAME ASCII Character	59	20	" " Vendor REV Level ASCII Character
23	4E	"N" Vendor NAME ASCII Character	60	03	Hex Byte of Laser Wavelength (Note 6)
24	41	"A" Vendor NAME ASCII Character	61	52	Hex Byte of Laser Wavelength (Note 6)
25	49	"I" Vendor NAME ASCII Character	62		RESERVED
26	52	"R" Vendor NAME ASCII Character	63		Check sum code for ID fields 0-62 (Note 7)
27	20	" " Vendor NAME ASCII Character	64	00	
28	20	" " Vendor NAME ASCII Character	65	02	RX_LOS
29	20	" " Vendor NAME ASCII Character	66	00	
30	20	" " Vendor NAME ASCII Character	67	00	
31	20	" " Vendor NAME ASCII Character	68-83		Serial Number, ASCII (Note 8)
32	20	" " Vendor NAME ASCII Character	84-91		Date Code (Note 9)
33	20	" " Vendor NAME ASCII Character	92	68	Diagnostic Monitoring Type
34	20	" " Vendor NAME ASCII Character	93	90	Enhanced Options
35	20	" " Vendor NAME ASCII Character	94	05	SFF-8472 rev 11.0
36	00		95		Checksum for bytes 64-94 (Note 7)
			96-255	00	

Notes:

1. FC-PI speed 100 MBytes/sec is a serial bit rate of 1.0625 GBit/sec.
2. RESERVED
3. Link distance with 62.5/125µm cable at 1.25Gbps is 275m.
4. RESERVED.
5. Table 1, Part number options/extensions
6. Laser wavelength is represented in 16 unsigned bits. The hex representation of 850nm is 0352.
7. Addresses 63 and 95 are checksums calculated per SFF-8472 and SFF-8074, and stored prior to product shipment.
8. Addresses 68-83 specify the module's ASCII serial number and will vary by unit.
9. Addresses 84-91 specify the module's ASCII date code and will vary according to manufactured date-code.

**050-337 Product Brief**  
**PCB Mount Quad Receiver**  
**100 Mbps – 5 Gbps, MMF, 3.3V**



Table 9 Two-Wire interface ID: Data Fields – Address A2h (RX1), A4h (RX2), A6h (RX3), A8h (RX4)

NOTE: TX Data fields are not applicable in this table (i.e. addresses 16-31 and 100-103)

Byte # Decimal	Data Notes	Byte # Decimal	Data Notes	Byte # Decimal	Data Notes
0	Temp H Alarm MSB (Note 1)	26	Reserved	104	Rx Pavg MSB (Note 5)
1	Temp H Alarm LSB (Note 1)	27	Reserved	105	Rx Pavg LSB (Note 5)
2	Temp L Alarm MSB (Note 1)	28	Reserved	106	Reserved
3	Temp L Alarm LSB (Note 1)	29	Reserved	107	Reserved
4	Temp H Warning MSB (Note 1)	30	Reserved	108	Reserved
5	Temp H Warning LSB (Note 1)	31	Reserved	109	Reserved
6	Temp L Warning MSB (Note 1)	32	RX Pwr H Alarm MSB (Note 5)	110	Status/Control
7	Temp L Warning LSB (Note 1)	33	RX Pwr H Alarm LSB (Note 5)	111	Reserved
8	Vcc H Alarm MSB (Note 2)	34	RX Pwr L Alarm MSB (Note 5)	112	Flag Bits
9	Vcc H Alarm LSB (Note 2)	35	RX Pwr L Alarm LSB (Note 5)	113	Flag Bits
10	Vcc L Alarm MSB (Note 2)	36	RX Pwr H Warning MSB (Note 5)	114	Reserved
11	Vcc L Alarm LSB (Note 2)	37	RX Pwr H Warning LSB (Note 5)	115	Reserved
12	Vcc H Warning MSB (Note 2)	38	RX Pwr L Warning MSB (Note 5)	116	Flag Bits
13	Vcc H Warning LSB (Note 2)	39	RX Pwr L Warning LSB (Note 5)	117	Flag Bits
14	Vcc L Warning MSB (Note 2)	40-45	Reserved	118	Reserved
15	Vcc L Warning LSB (Note 2)	56-94	External Cal Constants (Note 4)	119	Reserved
16	Reserved	95	Checksum for bytes 0-94	120-122	Reserved
17	Reserved	96	Temperature MSB (Note 1)	123	Reserved
18	Reserved	97	Temperature LSB (Note 1)	124	Reserved
19	Reserved	98	Vcc MSB (Note 2)	125	Reserved
20	Reserved	99	Vcc LSB (Note 2)	126	Reserved
21	Reserved	100	Reserved	127	Reserved (Note 8)
22	Reserved	101	Reserved	128-247	Customer Writable (Note 9)
23	Reserved	102	Reserved	248-255	Vendor Specific
24	Reserved	103	Reserved		
25	Reserved				

Notes:

1. Temperature (Temp) is decoded as a 16 bit signed twos compliment integer in increments of 1/256 °C.
2. Supply voltage (VCC) is decoded as a 16 bit unsigned integer in increments of 100 µV.
3. Laser bias current (Tx Bias) is decoded as a 16 bit unsigned integer in increments of 2 µA.
4. Transmitted average optical power (Tx Pwr) is decoded as a 16 bit unsigned integer in increments of 0.1 µW.
5. Received average optical power (Rx Pwr) is decoded as a 16 bit unsigned integer in increments of 0.1 µW.
6. Bytes 55-94 are not intended from use but have been set to default values per SFF-8472.
7. Bytes 95 is a checksum calculated (per SFF-8472) and stored prior to product shipment.
8. Byte 127 accepts a write but performs no action (reserved legacy byte).
9. Bytes 128-247 are write enabled (customer writable).

**050-337 Product Brief**  
**PCB Mount Quad Receiver**  
**100 Mbps – 5 Gbps, MMF, 3.3V**



**TABLE 10**      **DIGITAL DIAGNOSTIC MONITOR CHARACTERISTICS (WHEN APPLICABLE)**

**NOTE: TRANSMITTER PARAMETERS ARE NOT APPLICABLE**

PARAMETER	SYMBOL	MIN.	UNITS	NOTES
Transceiver Internal Temperature Accuracy	TINT	±3.0	°C	Temperature is measured internal to the transceiver and is valid from -40°C to +85 °C case temperature
Module internal Supply Voltage accuracy	VINT	±0.1	V	Supply voltage is measured internal to the transceiver and can, with less accuracy, be correlated to the voltage at the Vcc pin. Valid over 3.3V ±5%
Transmitter Laser DC Bias Current Accuracy	IINT	±10	%	
Transmitted Average Optical Output Power Accuracy	PT	±3.0	dB	Coupled into 50/125 mm MM fiber. Valid from -1dBm to -10dBm
Received Average Optical Input Power Accuracy	PR	±3.0	dB	Coupled from 50/125 mm MM fiber. Valid from -24 dBm to - 1 dBm