

VPA13

FBET Hybrid IC
Video Pack (VPA Series)
Video Output Amplifiers for
High-Resolution CRT Displays

Overview

The VPA13 is Video Output Amplifier for a High-Resolution Monochrome or RGB CRT Display integrates a complete amplifier using high-precision FBET and LSBT transistor chips into a single IC, allowing high-output voltage wide-bandwidth video output amplifier circuits to be implemented with greatly reduced parts count.

The result is that cost reduction and saving board space can be realized. VPA13's 9-pin metal SIP package also minimizes EMI problems and simplifies circuit board design.

The 130MHz bandwidth makes the VPA13 ideally suited for use with 64~75kHz line frequency monitors. A supply voltage of 90V is typical.

The VPA13 is one of the devices in a series of Sanyo's IC that cover the complete range of video output amplifier applications - - from high-end CAD/CAM monitors, desk top publishing monitors to externally high-resolution graphics displays. Evaluation samples are available now.

For others 64KHz line frequency monitor applications, refer to the VPA10/VPA12 (fV=100-120MHz bandwidth) Video Output Amplifier System data sheets.

Features

- High performance
- Up to 45Vp-p output voltage (VPA12 high swing version.)
- 130MHz typical bandwidth
- Simplifies circuit design
- Compact package
- Metal casing reduces EMI

Absolute Maximum Ratings at Ta=25°C

		unit
Maximum Supply Voltage	VCC	120 V
	VBB	15 V
Allowable Power Dissipation	PD (Ta=25°C)	3.5 W
	PD (Tc=25°C)	20 W
Junction Temperature	TJ	150 °C
Operating Temperature	Ta(op)	85 °C
Storage Temperature	Tstg	-20 to 110 °C

Connection and Outline

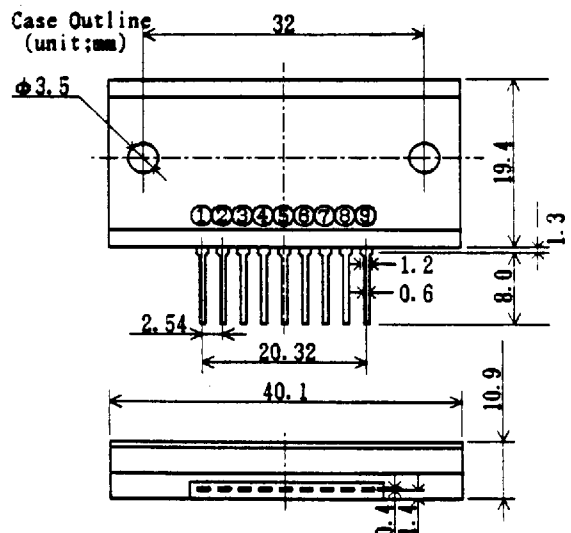
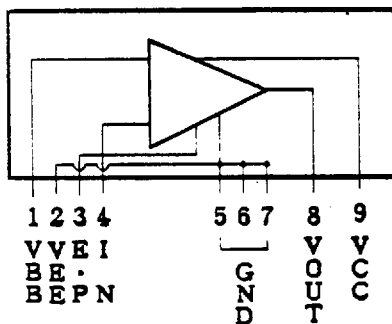

Specifications and information herein are subject to change without notice.

SANYO Electric Co., Ltd. Semiconductor Overseas Marketing Div.
 Natsume Bldg., 18-6, 2-chome, Yushima, Bunkyo-ku, TOKYO 113 JAPAN.

VPA13(Video Pack)

Recommended Operating Conditions at Ta=25°C

Condition	VCC	VBB	Vout	Vin(DC)	unit
Condition 1			-45Vp-p	3.5V	90 V
					10 V
Condition 2			-50Vp-p	3.8V	100 V
					10 V

Electrical Characteristics at Ta=25°C

Parameter	Symbol	Condition	Vout	min	typ	max	unit
Frequency Bandwidth	fc(-3dB)	Condition 1	45Vp-p	130	135		MHz
		Condition 2	50Vp-p	120	130		MHz
Voltage Gain	VG(DC)			12	14	16	times
Current Dissipation	ICC(1)	Condition 1	f=10 MHz clock		88		mA
		Condition 1	f=130MHz clock		133		mA
		Condition 2	f=10 MHz clock		98		mA
		Condition 2	f=130MHz clock		149		mA
Rise Time	Tr	Condition 2	10% to 90%		3.9		nS
Fall Time	Tf	Condition 2	10% to 90%		3.0		nS

(Note) Under Test Board Condition

- Emitter peaking: Re= 27Ω, Ce=100PF, Ce'=20PF
- Capacitive Load:10PF

Equivalent Circuit

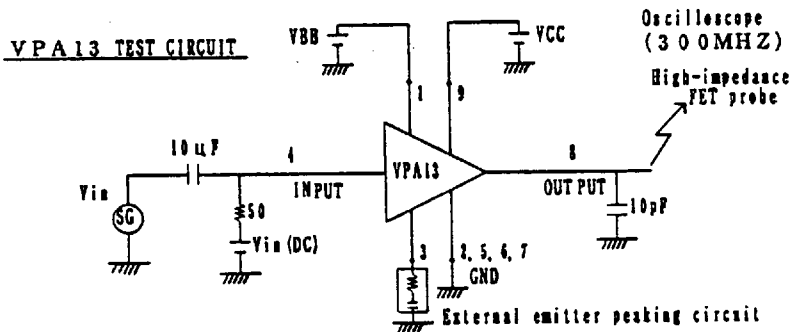
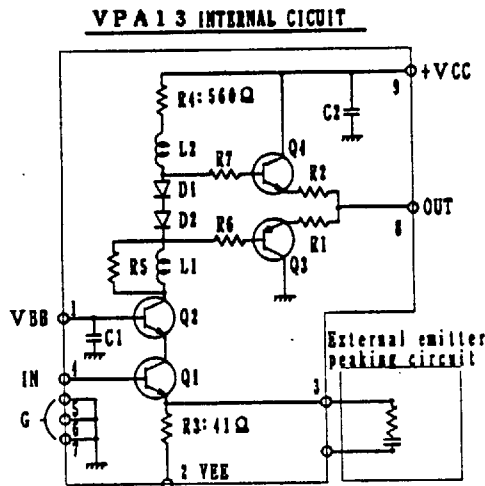

Precautions

- 1) Do not short the pins, or degradation may occur.
- 2) On heat sink design and test board condition, refer to the technical document "Sanyo Video Pack".
- 3) Case is connected to the internal GND.
- 4) The mounting torque should be in the range of 4 to 6Kg·cm

