



MH88610

Subscriber Line Interface Circuit (SLIC)

Preliminary Information

2

Features

- Transformerless 2-wire to 4-wire conversion
- Battery and ringing feed to line
- Off-hook and dial pulse detection
- Ring ground over-current protection
- Loop length detection
- Constant current feed

ISSUE 6

April 1995

Ordering Information

MH88610 20 Pin SIL Package

0°C to 70°C

Applications

Line interface for:

- PABX
- Intercoms
- Key Telephone Systems
- Control Systems

Description

The Mitel MH88610 Subscriber Line Interface Circuit provides a complete interface between a switching system and a subscriber loop. Functions provided include battery feed and ringing feed to the subscriber line, 2-Wire to 4-Wire hybrid interfacing, constant current, loop length and dial pulse detection. The device is fabricated using thick film hybrid technology in a 20-pin single in-line package.

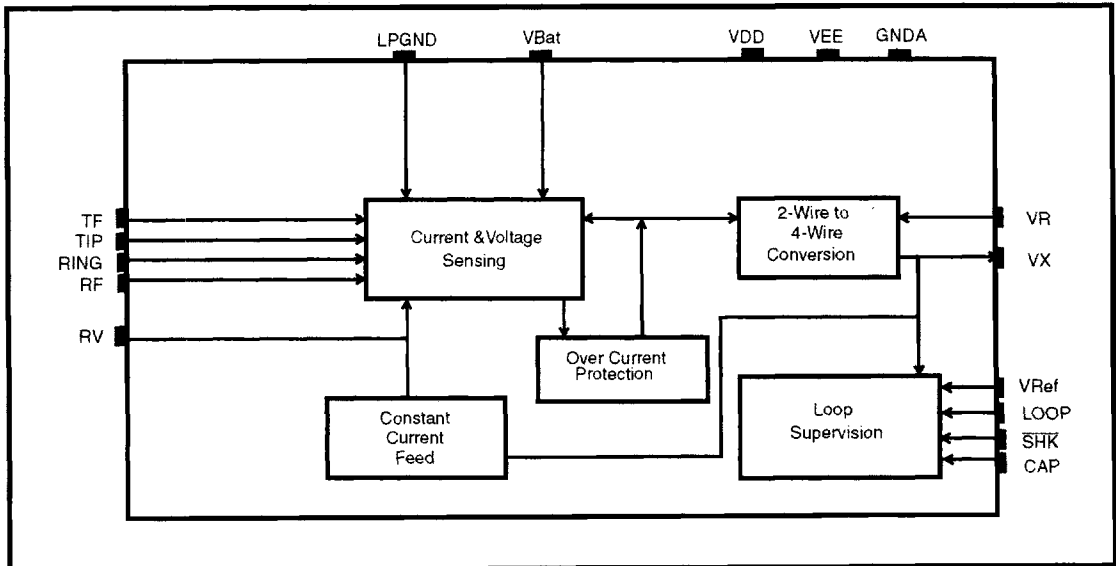

Figure 1 - Functional Block Diagram

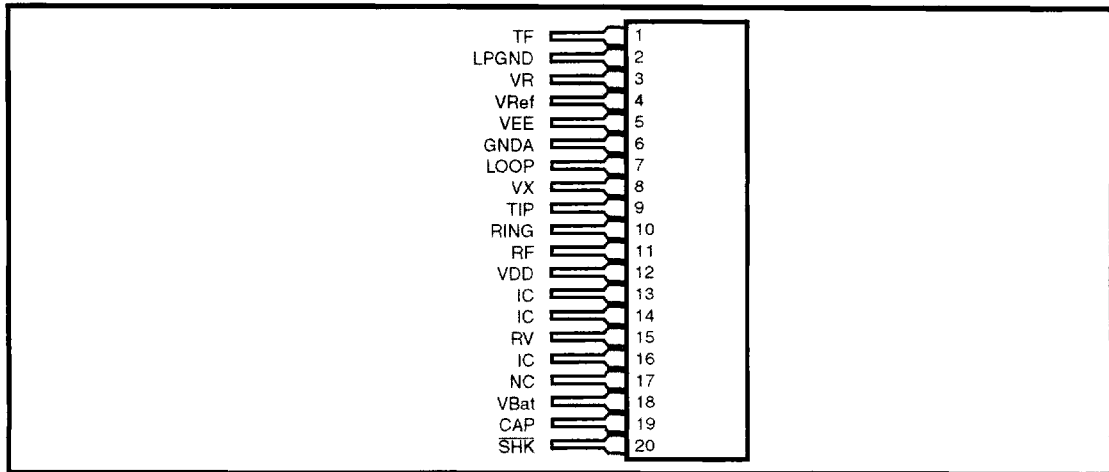

Figure 2 - Pin Connections

Pin Description

Pin #	Name	Description
1	TF	TF Tip Feed. Internal connection. Normally connects a pair of external diodes for protection.
2	LPGND	Loop Ground. is the system ground reference with respect to VBat.
3	VR	Voice Receive (input) is the 4 wire analog signal to the SLIC.
4	V _{Ref}	Voltage Reference (Input) to set the line current feed to the subscriber line.
5	V _{EE}	Negative Power Supply Voltage (-5V).
6	GNDA	Analog Ground (0V).
7	LOOP	Loop Monitor Voltage (Output). is proportional to the loop length.
8	VX	Voice Transmit (Output) is the 4-wire analog signal from the SLIC.
9	TIP	Connects to the "Tip" lead of the telephone line .
10	RING	Connects to the "Ring" lead of the telephone line.
11	RF	Ring Feed (Input) is normally connected to Ring relay for negative battery feed voltage and ringing voltage input.
12	V _{DD}	Positive Power Supply Voltage.
13	IC	Internal Connection. Pin cut short.
14	IC	Internal Connection. Pin cut short.
15	RV	Ring Feed Voltage connects to pin 11 (RF) through a normally closed ring relay.
16	IC	Internal Connection. Pin cut short.
17	NC	No Connection.
18	V _{Bat}	Negative Battery Feed Supply Voltage.
19	CAP	Connects external capacitor and resistor to ground for ring trip filter control.
20	SHK	Switch Hook Detect (Output). Digital output of an open-collector comparator. This output will go low (V _{EE}) when the subscriber line resistance falls below a set threshold value indicating that the telephone set has gone off-hook. This output can be monitored for dial pulse collection.

Functional Description

The MH88610 performs a transformerless 2-wire to 4-wire conversion of the analog signal. The 2-wire circuit is the balanced line going to the subscriber loop, while the 4-wire circuit is the audio signal going to an from devices such as the voice codec or switching circuit. The SLIC also provides two status signals. switch hook (\overline{SHK}) and loop length (Loop). The Loop signal is an analog voltage which is proportional to the loop length and the \overline{SHK} goes low when the telephone set is off-hook.

Constant Current Feed

The MH88610 employs a complex feedback circuit to supply a constant feed current to the line. This is done by sensing the sum of the voltages across the internal feed resistors and comparing it to an input reference voltage (V_{Ref}) that determines the constant feed current. This gives the loop current as:

$$I_{Loop} = 25 - \frac{V_{Ref}}{1.25} \text{ mA } (\pm 2 \text{ mA})$$

Switch Hook Detection

When the DC current exceeds an internal threshold level, the switch hook (\overline{SHK}) will go low. If the loop resistance is so high that V_{bat} can no longer supply the required amount of loop current as determined by constant current supply circuit, the output of the switch hook (\overline{SHK}) will go high impedance (open collector output) to indicate that the loop resistance is too high and the line is on hook.

Ringling And Ring Trip Detection

In Figure 3 a ringing signal (e.g., 90Vrms= \pm 48Vdc) is applied to the line by disconnecting pin 15 (RV) from pin 11(RF), and connecting the ringing voltage at pin 11 (RF) by use of the relay K1.

The SLIC can detect an off-hook condition during ringing but there is a large AC component which must be filtered out to give a true off-hook condition at \overline{SHK} .

A 1.0 μ F capacitor connected from pin 19 (CAP) to ground will provide adequate attenuation when ringing is applied. Once an off-hook condition has been detected an external circuit will deactivate the

relay (K1) to disconnect the ringing voltage from pin 11 and reconnect to pin 15. At that time the SLIC will revert to constant current feed operation.

For applications requiring Dial Pulse Detection the Capacitor connection to ground should be controlled such that the capacitor is only connected during ringing.

During off-hook conditions (closed loop), the capacitor should be switched out. This can be performed using a transistor, relay or system drive output of a codec. Applying GNDA to the Ring Trip Filter Control pin will switch in the filter, whilst removing GNDA, (with the switch in a tristate condition), will switch out the filter.

For applications using DTMF signalling, the capacitor can be permanently connected to ground.

Current Limit

The Tip or Ring may accidentally short to ground. In such a case, current will only flow through the feed resistor. This high current will be sensed and reduced by the current limit circuit to a lower value to protect the internal circuitry.

Components List

R1	=Resistor 1/4w, + 5%, 30.0k Ω
R2	=Resistor 1/4w, + 5%, 750k Ω
R3	=Resistor 1/4w, + 5%, 3.9k Ω
R4	=Resistor 1/4w, + 5%, 4.7k Ω
R5	=Resistor 1/4w, + 5%, 43k Ω
R6	=Resistor 1/4w, + 5%, 470k Ω
RV1*, RV2*	=Var. 160 VRMS, 250V,10J
D1*, D3*, D4*	=Diode Rect., 200V, 1A IN4003
D2	=Diode Rect., 200V, 1A IN4003
D5	=Diode Sw., 75V, 0.2A, 0.5W IN4148
Q	=NPN, 2N2222 or equivalent
K1	=Relay E/M, 12V, 1 form C
C1*,C2*,C3*,C4*	=Cap. Cer., 1.0 μ F, 50V, 20%
C5	=Cap. Elec., 1.0 μ F, 16V 10%

*Note: Components marked * are optional for extra protection of the hybrid.*

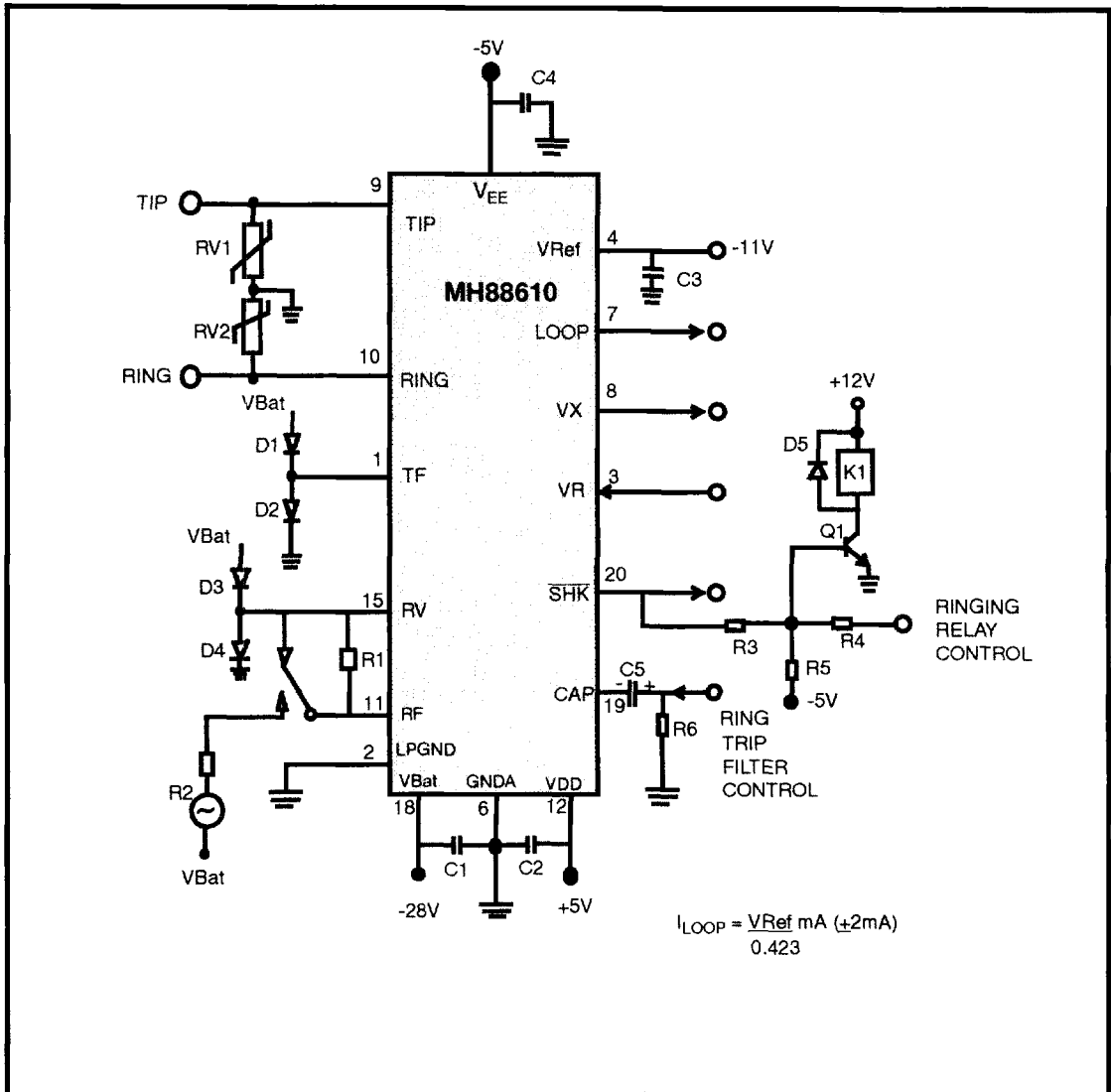

Figure 3 - Application Circuit

Absolute Maximum Ratings*

	Parameter	Symbol	Min	Max	Units
1	DC Supply Voltage LPGND=GND A	V_{DD}		+15	V
		V_{EE}	-15		V
		V_{Bat}	-60		V
2	Storage Temperature	T_S	-40	100	°C
3	Package Power Dissipation	PD		2	W

* Exceeding these values may cause permanent damage. Functional operation under these conditions is not implied.

Recommended Operating Conditions

	Parameter	Sym	Min	Typ [†]	Max	Units	Comments
1	Operating Supply Voltage	V_{DD}	4.75	5.0	5.25	V	
		V_{EE}	-5.25	-5.0	-4.75	V	
		V_{Ref}	-23	-11		V	
		V_{Bat}		-28		V	
2	Operating Temperature	T_O	0		70	°C	

† Typical figures are at 25 °C and are for design aid only.

DC Electrical Characteristics[†] - Voltages are with respect to GND A unless otherwise stated.

	Characteristics	Sym	Min	Typ [‡]	Max	Units	Test Conditions
1	Supply Current	V_{DD} I_{DD}		64	7.6	mA	
		V_{EE} I_{EE}		-3.4	-5.0	mA	
2	Power Consumption	P_C			212 1110	mW mW	Standby Active
3	Constant Current Line Feed	I_{Loop}	24	26	28	mA	
4	Operating Loop Resistance	R_{Loop}	800			Ω	$V_{Bat} = -28V$
5	Off-Hook Threshold			1200		Ω	$V_{Bat} = -28V$
6	Ring Ground Over-Current protection			33	42	mA	
7	Output High Voltage Loop (On-hook)		$V_{DD}-2$		V_{DD}	V	No Load
8	Output High Source Current Loop (on-hook)		15			mA	$R_{Loop} = 2.5V$
9	Output Low Voltage SHK Loop (off-hook)		V_{EE}		$V_{EE}+1.5$	V	10kΩ pull-up to 5V
			1.9		2.4	V	No Load
10	Output Low Sink Current SHK Loop (off-hook)		6	16		mA	$V_{SHK} = 1.5V$
			10	20		mA	$V_{Loop} = 2.5V$

† DC Electrical Characteristics are over recommended operating supply voltages.

‡ Typical figures are at 25 °C with nominal ±5V supplies and are for design aid only.

AC Electrical Characteristics

	Characteristics	Sym	Min	Typ*	Max	Units	Test Conditions
1	Ring Voltage (rms)	V_R			105	V_{rms}	
2	Ring Frequency		17		25	Hz	
3	Ringer Equivalence Number	REN			3		
4	Ring Trip Detect time				200	ms	
5	Input AC Impedance 2-wire	Z_{in}		600		Ω	
6	Input Impedance at V_R			230		$k\Omega$	
7	Output Impedance at V_x			1		Ω	
8	Gain 2-wire to V_x		0.60	0.62	0.70	dB	Input 6dBm at 2-wire
9	Gain V_R to 2-wire		-6.75	-6.69	-6.65	dB	Input 1.0V at V_R 600 Ω termination
10	2-wire Return Loss		20			dB	Input 0.5 V 1kHz 600 Ω
11	Transhybrid Loss	THL	40			dB	Input 0.5 V, 1kHz at V_R 600 Ω
12	Longitudinal Balance		45			dB	Input 0.5V 1kHz at metallic output voltage
13	Total Harmonic Distortion at V_x	THD		0.1	1.0	%	Input 6dBm at 2-wire
	at Tip and Ring			0.1	1.0	%	Input 1.0V at V_R
14	Common Mode Rejection Ratio 2-wire to V_x	CMRR	40			dB	Input 0.5Vrms, 1KHz at metallic output voltage
15	Idle channel Noise (at V_x)	N_c			15	dBrnC	C- Message
16	Power supply rejection ratio V_{DD}	PSRR	39			dB	At V_x , ripple at V_{pp} , 1kHz
	V_{DD}		37			dB	At 2-Wire, ripple at 1Vpp, 1kHz
	V_{EE}		23			dB	At V_x , ripple at 1Vpp, 1kHz
	V_{BAT}		23			dB	At 2-Wire, ripple at 1Vpp, 1kHz

* Typical figure are at 25°C and are for design aid only.

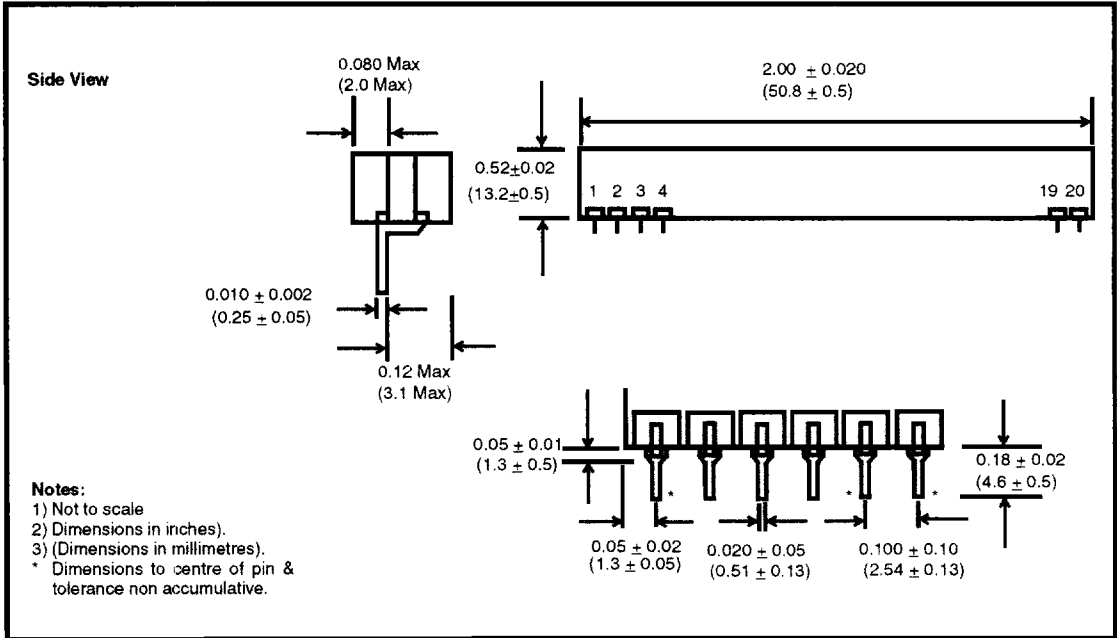

Figure 4 - Mechanical Data