

## MOS INTEGRATED CIRCUIT MC-421000A8, 421000A9 SERIES

### 1 M-WORD BY 8-BIT, 1 M-WORD BY 9-BIT DYNAMIC RAM MODULE FAST PAGE MODE

#### Description

The MC-421000A8 is a 1 048 576 words by 8 bits dynamic RAM module on which 2 pieces of 4 M DRAM ( $\mu$ PD424400LA) are assembled.

The MC-421000A9 is a 1 048 576 words by 9 bits dynamic RAM module on which 2 pieces of 4 M DRAM ( $\mu$ PD424400LA) and 1 piece of 1 M DRAM ( $\mu$ PD421000LA) are assembled.

These modules provide high density and large quantities of memory in a small space without utilizing the surface-mounting technology on the printed circuit board.

Decoupling capacitors are mounted on power supply line for noise reduction.

#### Features

- 1 048 576 words by 8 bits organization (MC-421000A8)
- 1 048 576 words by 9 bits organization (MC-421000A9)
- Fast access and cycle time

Family	Access time (MAX.)	R/W cycle time (MIN.)	Power consumption (MAX.)	
			Active	Standby
MC-421000A8-60	60 ns	120 ns	1 320 mW	11 mW (CMOS level input)
MC-421000A8-70	70 ns	140 ns	1 100 mW	
MC-421000A8-80	80 ns	160 ns	990 mW	
MC-421000A8-10	100 ns	190 ns	880 mW	
MC-421000A9-60	60 ns	120 ns	1 815 mW	16.5 mW (CMOS level input)
MC-421000A9-70	70 ns	140 ns	1 540 mW	
MC-421000A9-80	80 ns	160 ns	1 375 mW	
MC-421000A9-10	100 ns	190 ns	1 210 mW	

- 1 024 refresh cycles/16 ms
- Three refresh modes are available:  $\overline{\text{CAS}}$  before  $\overline{\text{RAS}}$  refresh,  $\overline{\text{RAS}}$  only refresh, Hidden refresh
- 30-pin single in-line memory module (Pin pitch=2.54 mm)
- All inputs and outputs are TTL compatible
- Single +5.0 V $\pm$ 10 % power supply

**Ordering Information**

Part number	Access time (MAX.)	Package	Mounted devices
MC-421000A8AA-60	60 ns	30-pin Single In-line Memory Module (Lead Type)	2 pieces of $\mu$ PD424400LA (300 mil SOJ)  [Single side]
MC-421000A8AA-70	70 ns		
MC-421000A8AA-80	80 ns		
MC-421000A8AA-10	100 ns		
MC-421000A8BA-60	60 ns	30-pin Single In-line Memory Module (Socket Type) Edge connector: Solder coating (HAL)	
MC-421000A8BA-70	70 ns		
MC-421000A8BA-80	80 ns		
MC-421000A8BA-10	100 ns		
MC-421000A8FA-60	60 ns	30-pin Single In-line Memory Module (Socket Type) Edge connector: Gold plating	
MC-421000A8FA-70	70 ns		
MC-421000A8FA-80	80 ns		
MC-421000A8FA-10	100 ns		
MC-421000A9AA-60	60 ns	30-pin Single In-line Memory Module (Lead Type)	2 pieces of $\mu$ PD424400LA (300 mil SOJ) 1 piece of $\mu$ PD421000LA (300 mil SOJ)  [Single side]
MC-421000A9AA-70	70 ns		
MC-421000A9AA-80	80 ns		
MC-421000A9AA-10	100 ns	30-pin Single In-line Memory Module (Socket Type) Edge connector: Solder coating (HAL)	
MC-421000A9BA-60	60 ns		
MC-421000A9BA-70	70 ns		
MC-421000A9BA-80	80 ns		
MC-421000A9BA-10	100 ns	30-pin Single In-line Memory Module (Socket Type) Edge connector: Gold plating	
MC-421000A9FA-60	60 ns		
MC-421000A9FA-70	70 ns		
MC-421000A9FA-80	80 ns		
MC-421000A9FA-10	100 ns		

**Quality Grade**

Standard

Please refer to "Quality grade on NEC Semiconductor Devices" (Document number IEI-1209) published by NEC Corporation to know the specification of quality grade on the devices and its recommended applications.

Pin Configurations (Front View)

[MC-421000A8 series]

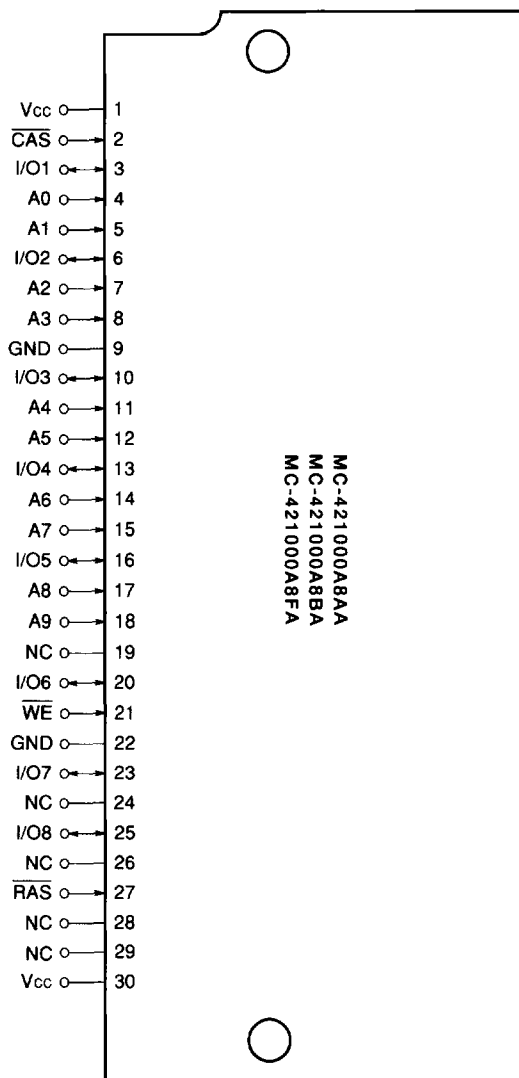

- A0-A9 : Address Inputs
- I/O1-I/O8 : Data Inputs/Outputs
- $\overline{\text{RAS}}$  : Row Address Strobe
- $\overline{\text{CAS}}$  : Column Address Strobe
- $\overline{\text{WE}}$  : Write Enable
- Vcc : Power Supply
- GND : Ground
- NC : No Connection

[MC-421000A9 series]

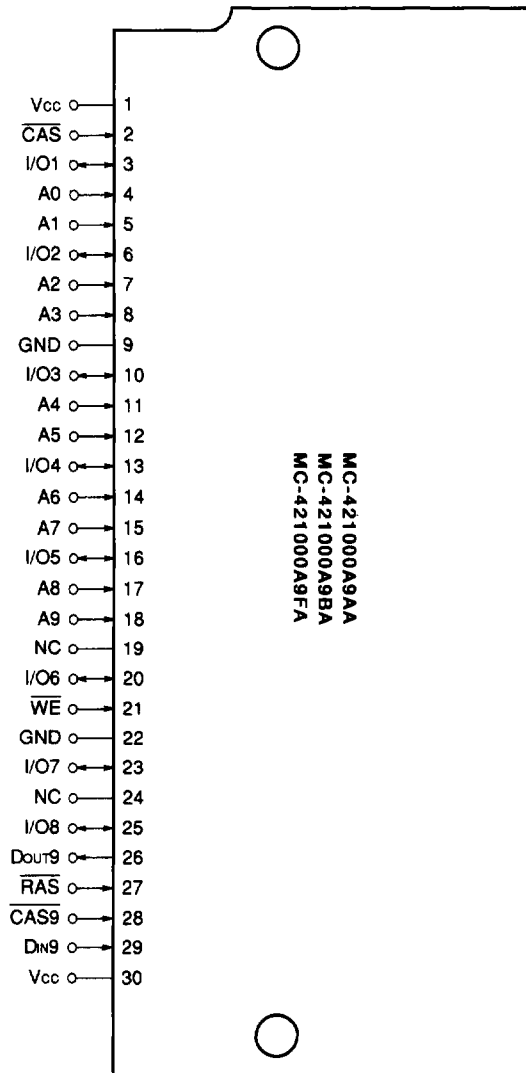

- A0-A9 : Address Inputs
- I/O1-I/O8 : Data Inputs/Outputs
- Din9 : Data Input
- Dout9 : Data Output
- $\overline{\text{RAS}}$  : Row Address Strobe
- $\overline{\text{CAS}}$ ,  $\overline{\text{CAS9}}$  : Column Address Strobe
- $\overline{\text{WE}}$  : Write Enable
- Vcc : Power Supply
- GND : Ground
- NC : No Connection

Block Diagrams

[MC-421000A8 series]

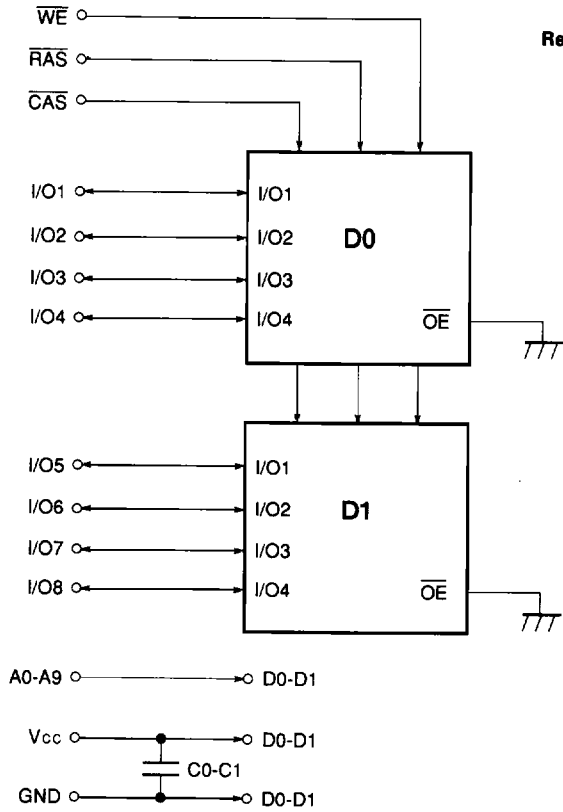

Remark D0-D1 :  $\mu$ PD424400LA

[MC-421000A9 series]

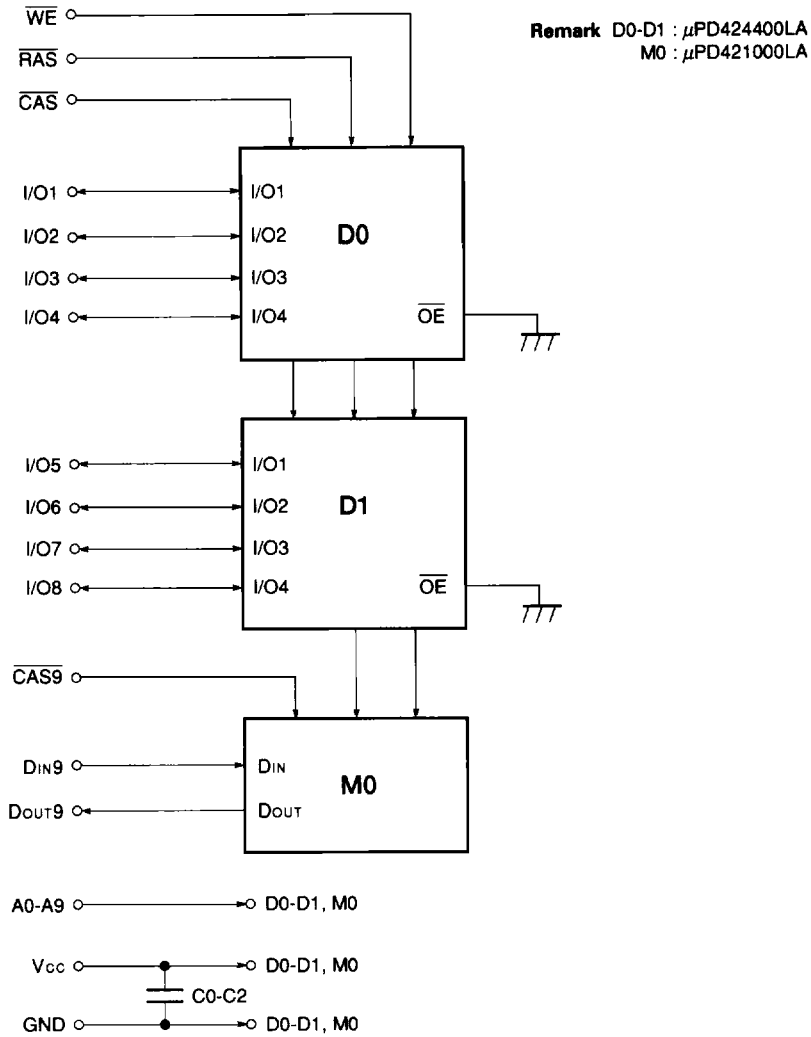

**Electrical Specifications** Notes 1, 2

**Absolute Maximum Ratings**

Parameter	Symbol	Condition	Rating	Unit
Voltage on any pin relative to GND	$V_T$		-1.0 to +7.0	V
Supply voltage	$V_{CC}$		-1.0 to +7.0	V
Output current	$I_O$		50	mA
Power dissipation	$P_D$	MC-421000A8	2	W
		MC-421000A9	3	
Operating temperature	$T_{opt}$		0 to +70	°C
Storage temperature	$T_{stg}$		-55 to +125	°C

**Remark** Exposing the device to stress above those listed in Absolute Maximum Ratings could cause permanent damage. The device is not meant to be operated under conditions outside the limits described in the operational section of this specification. Exposure to Absolute Maximum Rating conditions for extended periods may affect device reliability.

**Recommended Operating Conditions**

Parameter	Symbol	Condition	MIN.	TYP.	MAX.	Unit
Supply voltage	$V_{CC}$		4.5	5.0	5.5	V
High level input voltage	$V_{IH}$		2.4		$V_{CC} + 1.0$	V
Low level input voltage	$V_{IL}$		-1.0		+0.8	V
Ambient temperature	$T_a$		0		70	°C

**Capacitance** ( $T_a = +25\text{ °C}$ ,  $f = 1\text{ MHz}$ )

**[MC-421000A8 series]**

Parameter	Symbol	Test condition	MIN.	TYP.	MAX.	Unit
Input capacitance	$C_I$	A0-A9, $\overline{RAS}$ , $\overline{CAS}$ , $\overline{WE}$			24	pF
Data Input/Output capacitance	$C_{I/O}$	I/O1-I/O8			12	pF

**[MC-421000A9 series]**

Parameter	Symbol	Test condition	MIN.	TYP.	MAX.	Unit
Input capacitance	$C_{I1}$	A0-A9, $\overline{RAS}$ , $\overline{CAS}$ , $\overline{WE}$			31	pF
	$C_{I2}$	$\overline{CAS9}$ , $D_{IN9}$			17	pF
Data Input/Output capacitance	$C_{I/O}$	I/O1-I/O8			12	pF
Data Output capacitance	$C_O$	$D_{OUT9}$			17	pF

**DC Characteristics (Recommended Operating Conditions unless otherwise noted)**  
**[MC-421000A8 series]**

Parameter	Symbol	Test condition	MIN.	MAX.	Unit	Notes
Operating current	I <sub>CC1</sub>	$\overline{\text{RAS}}, \overline{\text{CAS}}$ Cycling $t_{\text{RC}} = t_{\text{RC(MIN.)}}$ $I_o = 0 \text{ mA}$	$t_{\text{RAC}} = 60 \text{ ns}$	240	mA	3,4
			$t_{\text{RAC}} = 70 \text{ ns}$	200		
			$t_{\text{RAC}} = 80 \text{ ns}$	180		
			$t_{\text{RAC}} = 100 \text{ ns}$	160		
Standby current	I <sub>CC2</sub>	$V_{\text{IH(MIN.)}} \leq \overline{\text{RAS}}, \overline{\text{CAS}}$ $I_o = 0 \text{ mA}$		4	mA	
		$V_{\text{CC}} - 0.2 \text{ V} \leq \overline{\text{RAS}}, \overline{\text{CAS}}$ $I_o = 0 \text{ mA}$		2		
$\overline{\text{RAS}}$ only refresh current	I <sub>CC3</sub>	$\overline{\text{RAS}}$ Cycling $V_{\text{IH(MIN.)}} \leq \overline{\text{CAS}}$ $t_{\text{RC}} = t_{\text{RC(MIN.)}}$ $I_o = 0 \text{ mA}$	$t_{\text{RAC}} = 60 \text{ ns}$	240	mA	3,4
			$t_{\text{RAC}} = 70 \text{ ns}$	200		
			$t_{\text{RAC}} = 80 \text{ ns}$	180		
			$t_{\text{RAC}} = 100 \text{ ns}$	160		
Operating current (Fast page mode)	I <sub>CC4</sub>	$\overline{\text{CAS}}$ Cycling $\overline{\text{RAS}} \leq V_{\text{IL(MAX.)}}$ $t_{\text{PC}} = t_{\text{PC(MIN.)}}$ $I_o = 0 \text{ mA}$	$t_{\text{RAC}} = 60 \text{ ns}$	180	mA	3,4
			$t_{\text{RAC}} = 70 \text{ ns}$	160		
			$t_{\text{RAC}} = 80 \text{ ns}$	140		
			$t_{\text{RAC}} = 100 \text{ ns}$	120		
$\overline{\text{CAS}}$ before $\overline{\text{RAS}}$ refresh current	I <sub>CC5</sub>	$\overline{\text{RAS}}$ Cycling $t_{\text{RC}} = t_{\text{RC(MIN.)}}$ $I_o = 0 \text{ mA}$	$t_{\text{RAC}} = 60 \text{ ns}$	240	mA	3,4
			$t_{\text{RAC}} = 70 \text{ ns}$	200		
			$t_{\text{RAC}} = 80 \text{ ns}$	180		
			$t_{\text{RAC}} = 100 \text{ ns}$	160		
Input leakage current	I <sub>I(L)</sub>	$V_i = 0 \text{ to } 5.5 \text{ V}$ all other pins not under test = 0 V	-10	+10	μA	
Output leakage current	I <sub>O(L)</sub>	$I/O1-I/O8$ are disabled (Hi-Z) $V_o = 0 \text{ to } 5.5 \text{ V}$	-10	+10	μA	
High level output voltage	V <sub>OH</sub>	$I_o = -5.0 \text{ mA}$	2.4		V	
Low level output voltage	V <sub>OL</sub>	$I_o = +4.2 \text{ mA}$		0.4	V	

[MC-421000A9 series]

Parameter	Symbol	Test condition	MIN.	MAX.	Unit	Notes
Operating current	I <sub>CC1</sub>	$\overline{\text{RAS}}, \overline{\text{CAS}}$ Cycling $t_{\text{RC}} = t_{\text{RC}(\text{MIN.})}$ $I_o = 0 \text{ mA}$	$t_{\text{RAC}} = 60 \text{ ns}$	330	mA	3,4
			$t_{\text{RAC}} = 70 \text{ ns}$	280		
			$t_{\text{RAC}} = 80 \text{ ns}$	250		
			$t_{\text{RAC}} = 100 \text{ ns}$	220		
Standby current	I <sub>CC2</sub>	$V_{\text{IH}(\text{MIN.})} \leq \overline{\text{RAS}}, \overline{\text{CAS}}$ $I_o = 0 \text{ mA}$	6	mA		
		$V_{\text{CC}} - 0.2 \text{ V} \leq \overline{\text{RAS}}, \overline{\text{CAS}}$ $I_o = 0 \text{ mA}$	3			
$\overline{\text{RAS}}$ only refresh current	I <sub>CC3</sub>	$\overline{\text{RAS}}$ Cycling $V_{\text{IH}(\text{MIN.})} \leq \overline{\text{CAS}}$ $t_{\text{RC}} = t_{\text{RC}(\text{MIN.})}$ $I_o = 0 \text{ mA}$	$t_{\text{RAC}} = 60 \text{ ns}$	330	mA	3,4
			$t_{\text{RAC}} = 70 \text{ ns}$	280		
			$t_{\text{RAC}} = 80 \text{ ns}$	250		
			$t_{\text{RAC}} = 100 \text{ ns}$	220		
Operating current (Fast page mode)	I <sub>CC4</sub>	$\overline{\text{CAS}}$ Cycling $\overline{\text{RAS}} \leq V_{\text{IL}(\text{MAX.})}$ $t_{\text{PC}} = t_{\text{PC}(\text{MIN.})}$ $I_o = 0 \text{ mA}$	$t_{\text{RAC}} = 60 \text{ ns}$	260	mA	3,4
			$t_{\text{RAC}} = 70 \text{ ns}$	230		
			$t_{\text{RAC}} = 80 \text{ ns}$	200		
			$t_{\text{RAC}} = 100 \text{ ns}$	170		
$\overline{\text{CAS}}$ before $\overline{\text{RAS}}$ refresh current	I <sub>CC5</sub>	$\overline{\text{RAS}}$ Cycling $t_{\text{RC}} = t_{\text{RC}(\text{MIN.})}$ $I_o = 0 \text{ mA}$	$t_{\text{RAC}} = 60 \text{ ns}$	330	mA	3,4
			$t_{\text{RAC}} = 70 \text{ ns}$	280		
			$t_{\text{RAC}} = 80 \text{ ns}$	250		
			$t_{\text{RAC}} = 100 \text{ ns}$	220		
Input leakage current	I <sub>I(L)</sub>	$V_i = 0 \text{ to } 5.5 \text{ V}$ all other pins not under test = 0 V	-10	+10	μA	
Output leakage current	I <sub>O(L)</sub>	$I/O1-I/O8, D_{\text{OUT}9}$ are disabled (Hi-Z) $V_o = 0 \text{ to } 5.5 \text{ V}$	-10	+10	μA	
High level output voltage	V <sub>OH</sub>	$I_o = -5.0 \text{ mA}$	2.4		V	
Low level output voltage	V <sub>OL</sub>	$I_o = +4.2 \text{ mA}$		0.4	V	

AC Characteristics

(Recommended Operating Conditions unless otherwise noted) Notes 5, 6

[MC-421000A8 series]

Parameter	Symbol	t <sub>RAC</sub> = 60 ns		t <sub>RAC</sub> = 70 ns		t <sub>RAC</sub> = 80 ns		t <sub>RAC</sub> = 100 ns		Unit	Notes
		MIN.	MAX.	MIN.	MAX.	MIN.	MAX.	MIN.	MAX.		
Random Read or Write Cycle Time	t <sub>RC</sub>	120		140		160		190		ns	7
Fast Page Mode Cycle Time (Read or Write)	t <sub>PC</sub>	40		45		50		60		ns	7
Access Time from $\overline{\text{RAS}}$	t <sub>RAC</sub>		60		70		80		100	ns	8, 9
Access Time from $\overline{\text{CAS}}$ (Falling Edge)	t <sub>CAC</sub>		15		20		20		25	ns	8, 9
Access Time from Column Address	t <sub>AA</sub>		30		35		40		50	ns	8, 9
Access Time from $\overline{\text{CAS}}$ Precharge	t <sub>ACP</sub>		35		40		45		55	ns	9
$\overline{\text{RAS}}$ to Column Address Delay Time	t <sub>RAD</sub>	15	30	15	35	17	40	17	50	ns	8
$\overline{\text{CAS}}$ to Data Setup Time	t <sub>CLZ</sub>	0		0		0		0		ns	9
Output Buffer Turn-off Delay Time ( $\overline{\text{CAS}}$ )	t <sub>OFF</sub>	0	15	0	15	0	20	0	25	ns	10
Transition Time (Rise and Fall)	t <sub>T</sub>	3	50	3	50	3	50	3	50	ns	
$\overline{\text{RAS}}$ Precharge Time	t <sub>RP</sub>	50		60		70		80		ns	
$\overline{\text{RAS}}$ Pulse Width (Random Read, Write Cycle)	t <sub>RAS</sub>	60	10 000	70	10 000	80	10 000	100	10 000	ns	
$\overline{\text{RAS}}$ Pulse Width (Fast Page Mode)	t <sub>RASP</sub>	60	125 000	70	125 000	80	125 000	100	125 000	ns	
$\overline{\text{RAS}}$ Hold Time	t <sub>RSH</sub>	20		20		20		25		ns	
$\overline{\text{CAS}}$ Pulse Width	t <sub>CAS</sub>	15	10 000	20	10 000	20	10 000	25	10 000	ns	
$\overline{\text{CAS}}$ Hold Time	t <sub>CSH</sub>	60		70		80		100		ns	
$\overline{\text{RAS}}$ to $\overline{\text{CAS}}$ Delay Time	t <sub>RCD</sub>	20	40	20	50	25	60	25	75	ns	8
$\overline{\text{CAS}}$ to $\overline{\text{RAS}}$ Precharge Time	t <sub>CRP</sub>	10		10		10		10		ns	11
$\overline{\text{CAS}}$ Precharge Time	t <sub>CPN</sub>	10		10		10		10		ns	
$\overline{\text{CAS}}$ Precharge Time (Fast Page Mode)	t <sub>CP</sub>	10		10		10		10		ns	
$\overline{\text{RAS}}$ Precharge $\overline{\text{CAS}}$ Hold Time	t <sub>RPC</sub>	10		10		10		10		ns	
$\overline{\text{RAS}}$ Hold Time from $\overline{\text{CAS}}$ Precharge	t <sub>RHCP</sub>	35		40		45		55		ns	
Row Address Setup Time	t <sub>ASR</sub>	0		0		0		0		ns	
Row Address Hold Time	t <sub>RAH</sub>	10		10		12		12		ns	
Column Address Setup Time	t <sub>ASC</sub>	0		0		0		0		ns	
Column Address Hold Time	t <sub>CAH</sub>	15		15		15		20		ns	
Column Address Lead Time Referenced to $\overline{\text{RAS}}$	t <sub>RAL</sub>	30		35		40		50		ns	
Read Command Setup Time	t <sub>RCS</sub>	0		0		0		0		ns	
Read Command Hold Time Referenced to $\overline{\text{RAS}}$	t <sub>RRH</sub>	10		10		10		10		ns	12
Read Command Hold Time Referenced to $\overline{\text{CAS}}$	t <sub>RCH</sub>	0		0		0		0		ns	12
Write Command Hold Time Referenced to $\overline{\text{CAS}}$	t <sub>WCH</sub>	15		15		15		20		ns	13
Data-in Setup Time	t <sub>DS</sub>	0		0		0		0		ns	14
Data-in Hold Time	t <sub>DH</sub>	15		15		15		20		ns	14
$\overline{\text{WE}}$ Command Setup Time	t <sub>WCS</sub>	0		0		0		0		ns	15
$\overline{\text{CAS}}$ Setup Time for $\overline{\text{CAS}}$ before $\overline{\text{RAS}}$ Refresh	t <sub>CSR</sub>	10		10		10		10		ns	
$\overline{\text{CAS}}$ Hold Time for $\overline{\text{CAS}}$ before $\overline{\text{RAS}}$ Refresh	t <sub>CHR</sub>	15		15		15		20		ns	
$\overline{\text{WE}}$ Setup Time	t <sub>WSR</sub>	10		10		10		10		ns	
$\overline{\text{WE}}$ Hold Time	t <sub>WHR</sub>	15		15		15		20		ns	
Refresh Time	t <sub>REF</sub>		16		16		16		16	ms	

[MC-421000A9 series]

(1/2)

Parameter	Symbol	t <sub>RAC</sub> = 60 ns		t <sub>RAC</sub> = 70 ns		t <sub>RAC</sub> = 80 ns		t <sub>RAC</sub> = 100 ns		Unit	Notes
		MIN.	MAX.	MIN.	MAX.	MIN.	MAX.	MIN.	MAX.		
Random Read or Write Cycle Time	t <sub>RC</sub>	120		140		160		190		ns	7
Read Write Cycle Time	t <sub>RWC</sub>	145		155		190		225		ns	7
Fast Page Mode Cycle Time (Read or Write)	t <sub>PC</sub>	40		45		50		60		ns	7
Read Modify Write Cycle Time (Fast Page Mode)	t <sub>PRWC</sub>	65		70		75		90		ns	7
Access Time from $\overline{\text{RAS}}$	t <sub>RAC</sub>		60		70		80		100	ns	8, 9
Access Time from $\overline{\text{CAS}}$ (Falling Edge)	t <sub>CAC</sub>		20		20		20		25	ns	8, 9
Access Time from Column Address	t <sub>AA</sub>		30		35		45		50	ns	8, 9
Access Time from $\overline{\text{CAS}}$ Precharge	t <sub>ACP</sub>		35		40		45		55	ns	9
$\overline{\text{RAS}}$ to Column Address Delay Time	t <sub>RAD</sub>	15	30	15	35	17	40	17	50	ns	8
$\overline{\text{CAS}}$ to Data Setup Time	t <sub>CLZ</sub>	0		0		0		0		ns	9
Output Buffer Turn-off Delay Time ( $\overline{\text{CAS}}$ )	t <sub>OFF</sub>	0	15	0	15	0	20	0	25	ns	10
Transition Time (Rise and Fall)	t <sub>T</sub>	3	50	3	50	3	50	3	50	ns	
$\overline{\text{RAS}}$ Precharge Time	t <sub>RP</sub>	50		60		70		80		ns	
$\overline{\text{RAS}}$ Pulse Width (Random Read, Write Cycle)	t <sub>RAS</sub>	60	10 000	70	10 000	80	10 000	100	10 000	ns	
$\overline{\text{RAS}}$ Pulse Width (Fast Page Mode)	t <sub>RASP</sub>	60	125 000	70	125 000	80	125 000	100	125 000	ns	
$\overline{\text{RAS}}$ Hold Time	t <sub>RSH</sub>	20		20		20		25		ns	
$\overline{\text{CAS}}$ Pulse Width	t <sub>CAS</sub>	20	10 000	20	10 000	20	10 000	25	10 000	ns	
$\overline{\text{CAS}}$ Hold Time	t <sub>CSH</sub>	60		70		80		100		ns	
$\overline{\text{RAS}}$ to $\overline{\text{CAS}}$ Delay Time	t <sub>RCD</sub>	20	40	20	50	25	60	25	75	ns	8
$\overline{\text{CAS}}$ to $\overline{\text{RAS}}$ Precharge Time	t <sub>CRP</sub>	10		10		10		10		ns	11
$\overline{\text{CAS}}$ Precharge Time	t <sub>CPN</sub>	10		10		10		10		ns	
$\overline{\text{CAS}}$ Precharge Time (Fast Page Mode)	t <sub>CP</sub>	10		10		10		10		ns	
$\overline{\text{RAS}}$ Precharge $\overline{\text{CAS}}$ Hold Time	t <sub>RPC</sub>	10		10		10		10		ns	
$\overline{\text{RAS}}$ Hold Time from $\overline{\text{CAS}}$ Precharge	t <sub>RHCP</sub>	35		40		45		55		ns	
Row Address Setup Time	t <sub>ASR</sub>	0		0		0		0		ns	
Row Address Hold Time	t <sub>RAH</sub>	10		10		12		12		ns	
Column Address Setup Time	t <sub>ASC</sub>	0		0		0		0		ns	
Column Address Hold Time	t <sub>CAH</sub>	15		17		20		20		ns	
Column Address Lead Time Referenced to $\overline{\text{RAS}}$	t <sub>RAL</sub>	30		35		45		50		ns	
Read Command Setup Time	t <sub>RCS</sub>	0		0		0		0		ns	
Read Command Hold Time Referenced to $\overline{\text{RAS}}$	t <sub>RRH</sub>	10		10		10		10		ns	12
Read Command Hold Time Referenced to $\overline{\text{CAS}}$	t <sub>RCH</sub>	0		0		0		0		ns	12
Write Command Hold Time Referenced to $\overline{\text{CAS}}$	t <sub>WCH</sub>	15		15		15		20		ns	13
Write Command Pulse Width	t <sub>WP</sub>	15		15		15		20		ns	13
Data-in Setup Time	t <sub>DS</sub>	0		0		0		0		ns	14
Data-in Hold Time	t <sub>DH</sub>	15		15		20		20		ns	14
$\overline{\text{WE}}$ Command Setup Time	t <sub>WCS</sub>	0		0		0		0		ns	15
$\overline{\text{CAS}}$ to $\overline{\text{WE}}$ Delay Time	t <sub>CWD</sub>	20		20		20		25		ns	15
$\overline{\text{RAS}}$ to $\overline{\text{WE}}$ Delay Time	t <sub>RWD</sub>	60		70		80		100		ns	15

(2/2)

Parameter	Symbol	t <sub>RAC</sub> = 60 ns		t <sub>RAC</sub> = 70 ns		t <sub>RAC</sub> = 80 ns		t <sub>RAC</sub> = 100 ns		Unit	Notes
		MIN.	MAX.	MIN.	MAX.	MIN.	MAX.	MIN.	MAX.		
CAS Precharge Delay Time Referenced to $\overline{WE}$ (Fast Page Mode)	t <sub>CPWD</sub>	55		60		70		85		ns	15
Column Address Delay Time Referenced to $\overline{WE}$	t <sub>AWD</sub>	30		35		45		50		ns	15
Write Command Lead Time Referenced to $\overline{RAS}$	t <sub>RWL</sub>	20		20		25		30		ns	
Write Command Lead Time Referenced to $\overline{CAS}$	t <sub>CWL</sub>	15		15		15		20		ns	
CAS Setup Time for $\overline{CAS}$ before $\overline{RAS}$ Refresh	t <sub>CSR</sub>	10		10		10		10		ns	
CAS Hold Time for $\overline{CAS}$ before $\overline{RAS}$ Refresh	t <sub>CHR</sub>	15		15		15		20		ns	
$\overline{WE}$ Setup Time	t <sub>WSR</sub>	10		10		10		10		ns	
$\overline{WE}$ Hold Time	t <sub>WHR</sub>	15		15		15		20		ns	
Refresh Time	t <sub>REF</sub>		16		16		16		16	ms	

Notes

1. All voltages are referenced to GND.
2. After power-up, wait more than 100  $\mu$ s and then, execute eight  $\overline{\text{CAS}}$  before  $\overline{\text{RAS}}$  or  $\overline{\text{RAS}}$  only refresh cycles to initialize the internal circuit.
3.  $t_{CC1}$ ,  $t_{CC3}$ ,  $t_{CC4}$  and  $t_{CC5}$  depend on  $t_{RC}$  and  $t_{PC}$ . Specified values are obtained with outputs open.
4. Address can be changed once or less while  $\overline{\text{RAS}} = V_{IL}$  and  $\overline{\text{CAS}} = V_{IH}$ .
5. AC measurements assume  $t_r = 5$  ns.
6. AC Characteristics test condition

(1) Input timing specification

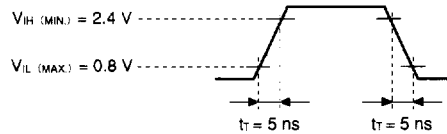

(2) Output timing specification

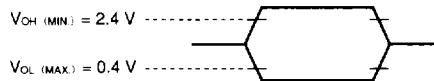

7. The minimum specifications are used only to indicate cycle time at which proper operation over the full temperature range ( $T_a = 0$  to  $70$  °C) is assured.
8. In random read cycle, the access time is changed by the conditions of  $t_{RAD}$  and  $t_{RCD}$  as follows.

Condition	Access Time
$t_{RAD} \leq t_{RAD (MAX.)}$ and $t_{RCD} \leq t_{RCD (MAX.)}$	$t_{RAC (MAX.)}$
$t_{RAD} > t_{RAD (MAX.)}$ and $t_{RCD} \leq t_{RCD (MAX.)}$	$t_{AA (MAX.)}$
$t_{RCD} > t_{RCD (MAX.)}$	$t_{CAC (MAX.)}$

$t_{RAD (MAX.)}$  and  $t_{RCD (MAX.)}$  indicate the points which the access time changes and are not the limits of operation.

9. Loading conditions are 2 TTL and 100 pF.
10.  $t_{OFF (MAX.)}$  defines the time at which the output achieves the open-circuit condition and is not referenced to  $V_{OH}$  or  $V_{OL}$ .
11.  $t_{CRP (MIN.)}$  requirement should be applicable for  $\overline{\text{RAS}}$  /  $\overline{\text{CAS}}$  cycles preceded by any cycles.
12. Either  $t_{RCH (MIN.)}$  or  $t_{RRH (MIN.)}$  must be satisfied for a read cycle.
13.  $t_{WP (MIN.)}$  is applicable for late write cycle or read modify write cycle. In early write cycles,  $t_{WCH (MIN.)}$  should be satisfied.
14.  $t_{DS (MIN.)}$  and  $t_{DH (MIN.)}$  are referenced to  $\overline{\text{CAS}}$  falling edge in early write cycles and to  $\overline{\text{WE}}$  falling edge in late write or read modify write cycles.
15. If  $t_{WCS} \geq t_{WCS (MIN.)}$ , the cycle is an early write cycle and the data out will remain Hi-Z through the entire cycle. If  $t_{RWD} \geq t_{RWD (MIN.)}$ ,  $t_{CWD} \geq t_{CWD (MIN.)}$ ,  $t_{AWD} \geq t_{AWD (MIN.)}$  and  $t_{CPWD} \geq t_{CPWD (MIN.)}$ , the cycle is a read modify write cycle and the data out will contain data read from the selected cell. If neither of the above condition is met, the state of the data out is indeterminate.



**Late Write Cycle (Only for the MC-421000A9 series)**

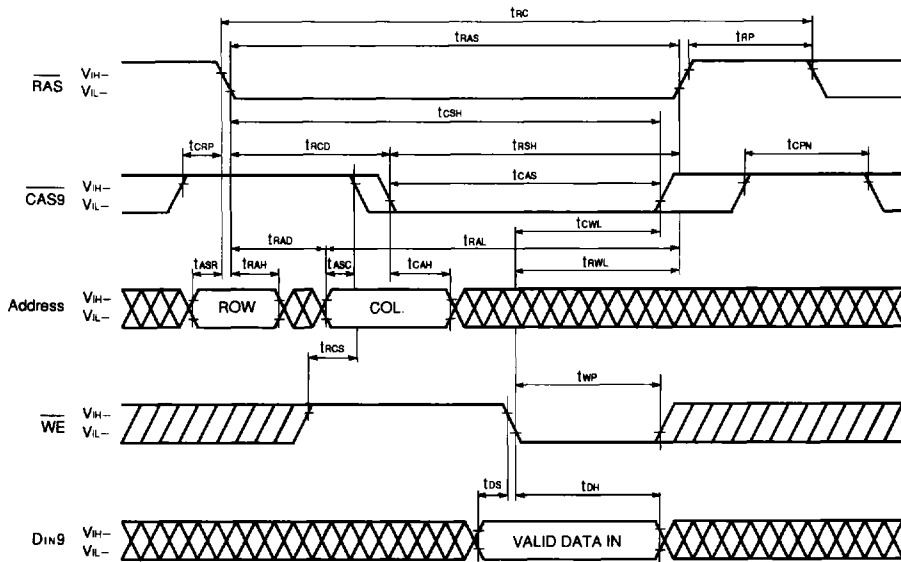

**Read Modify Write Cycle (Only for the MC-421000A9 series)**

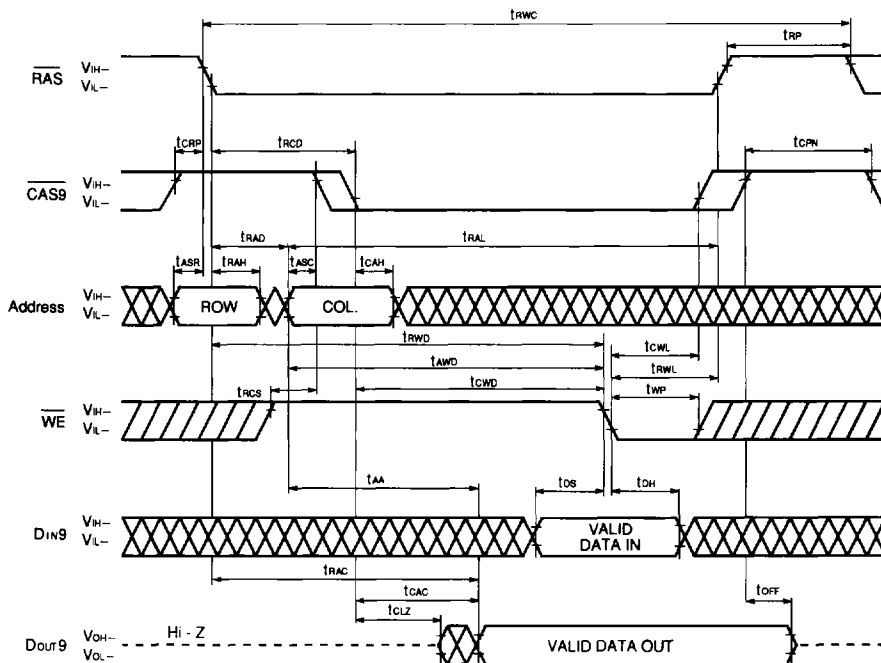





**CAS Before RAS Refresh Cycle**

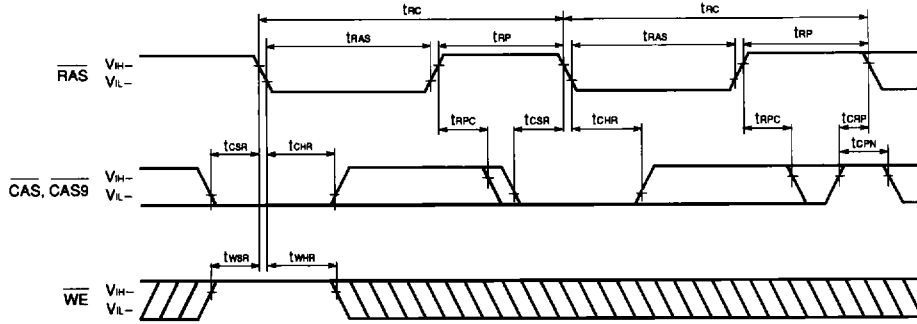

**Remark** Address, D<sub>10</sub>9 = Don't care I/O, D<sub>out</sub>9 = Hi-Z

**RAS Only Refresh Cycle**

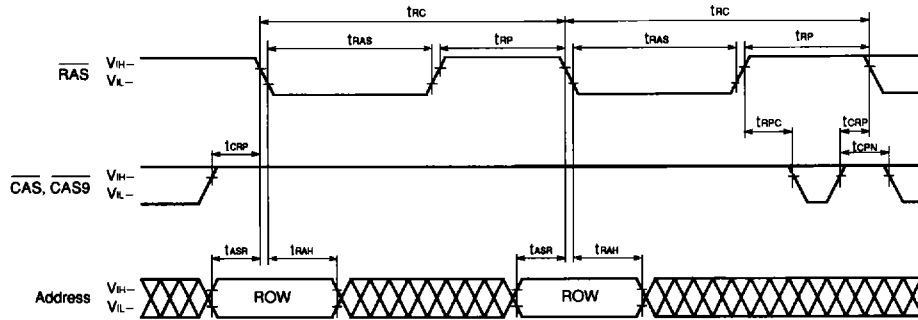

**Remark** WE, D<sub>10</sub>9 = Don't care I/O, D<sub>out</sub>9 = Hi-Z

Hidden Refresh Cycle

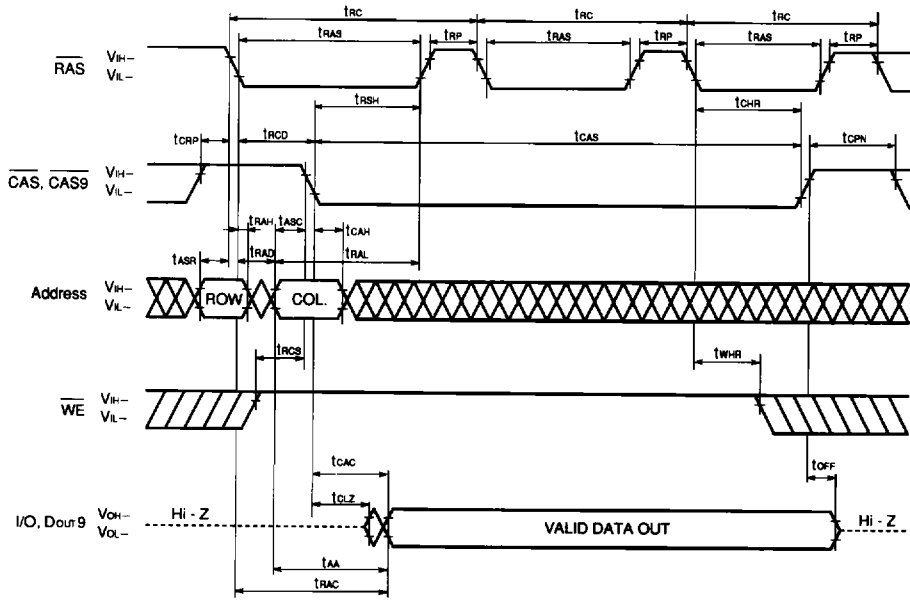

Remark  $D_{IN9}$  = Don't care

Package Drawings

MC-421000A8AA

30 PIN SINGLE IN-LINE MODULE (LEAD TYPE)

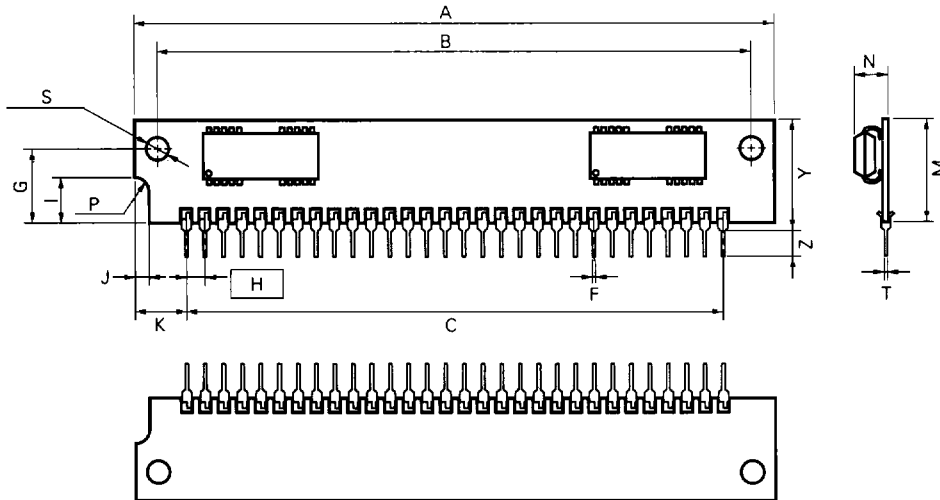

M30A-100A4-2

ITEM	MILLIMETERS	INCHES
A	88.9±0.13	3.500±0.006
B	82.14	3.234
C	73.66	2.900
F	0.5	0.020
G	10.16	0.400
H	2.54 (T.P.)	0.100 (T.P.)
I	6.35	0.250
J	2.03	0.080
K	7.62	0.300
M	16.51	0.65
N	5.08 MAX.	0.200 MAX.
P	R 2.0	R 0.079
S	∅3.18	∅0.125
T	0.25	0.010
Y	18.2 MAX.	0.717 MAX.
Z	3.4±0.5	0.134±0.020

MC-421000A8BA, 421000A8FA  
30 PIN SINGLE IN-LINE MODULE (SOCKET TYPE)

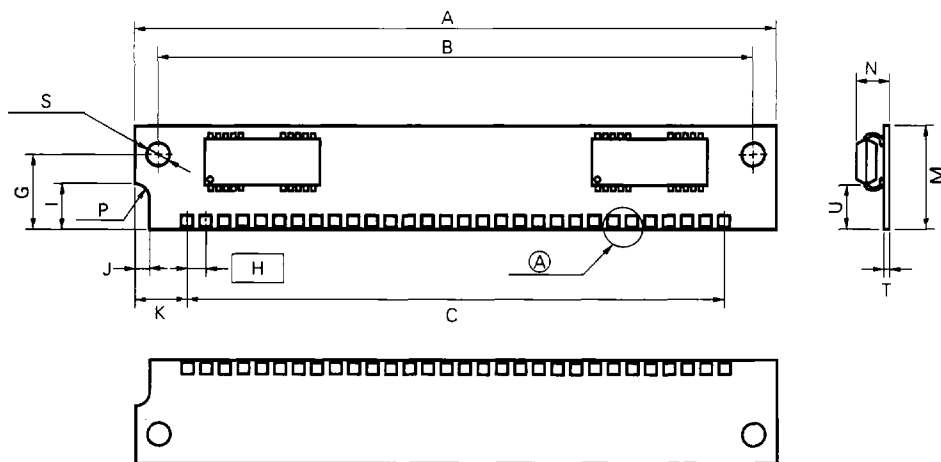

M30B-100A4-2

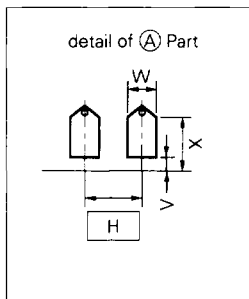

ITEM	MILLIMETERS	INCHES
A	88.9±0.13	3.500±0.006
B	82.14	3.234
C	73.66	2.900
G	10.16	0.400
H	2.54 (T.P.)	0.100 (T.P.)
I	6.35	0.250
J	2.03	0.080
K	7.62	0.300
M	16.51	0.65
N	5.08 MAX.	0.200 MAX.
P	R 2.0	R 0.079
S	∅3.18	∅0.125
T	1.27±0.08	0.050±0.004
U	4.86 MIN.	0.191 MIN.
V	0.25 MAX.	0.010 MAX.
W	1.8±0.05	0.071 <sup>+0.002</sup> <sub>-0.003</sub>
X	2.1 MIN.	0.082 MIN.

MC-421000A9AA

30 PIN SINGLE IN-LINE MODULE (LEAD TYPE)

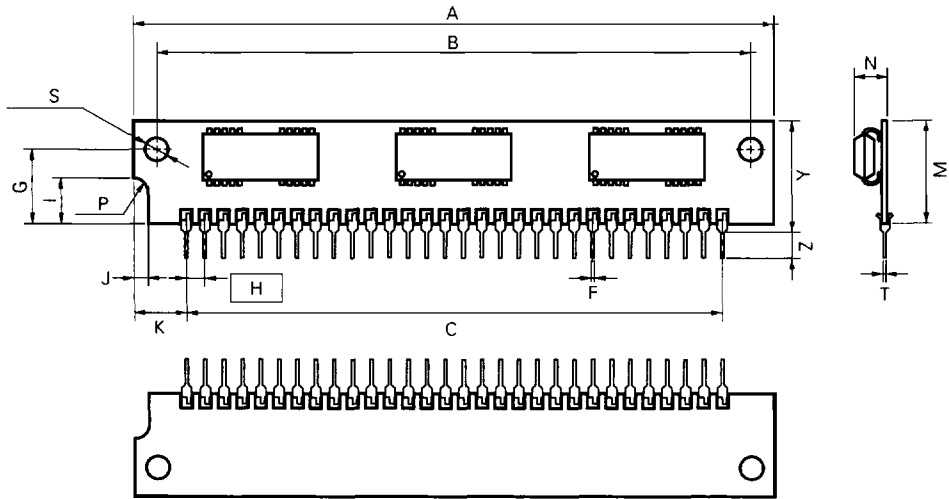

M30A-100A5-2

ITEM	MILLIMETERS	INCHES
A	88.9±0.13	3.500±0.006
B	82.14	3.234
C	73.66	2.900
F	0.5	0.020
G	10.16	0.400
H	2.54 (T.P.)	0.100 (T.P.)
I	6.35	0.250
J	2.03	0.080
K	7.62	0.300
M	16.51	0.65
N	5.08 MAX.	0.200 MAX.
P	R 2.0	R 0.079
S	∅3.18	∅0.125
T	0.25	0.010
Y	18.2 MAX.	0.717 MAX.
Z	3.4±0.5	0.134±0.020

