

TMC2272

Digital Colorspace Converter/Corrector

36-Bit Color (12 Bits x 3 Components) 40 MHz

Description

A 40 MHz, three-channel, 36 bit (three 12-bit components) colorspace converter and color corrector, the TMC2272 uses 9 parallel multipliers to process high-resolution imagery in real time.

The TMC2272 also operates at any slower clock rate and with any smaller data path width, allowing it to handle all broadcast and consumer camera, frame-grabber, encoder/decoder, recorder and monitor applications as well as most electronic imaging applications.

The TMC2272's processing ability allows colorspace to be optimized for every input or output device; camera, monitor, transmission or storage medium in real time, regardless of the signal format required by each stage in a system. For instance, a frame buffer may be operated in any desired colorspace in an otherwise RGB system with the use of two TMC2272s for translation to and from the desired frame-buffer colorspace.

A complete set of three 12-bit samples is processed on every clock cycle, with a five-cycle pipeline latency. Full 23-bit (for each of three components) internal precision is provided with 10-bit user-defined coefficients. The coefficients may be varied dynamically, with three new coefficients loaded every clock cycle. (The full set of nine can be replaced in three clock cycles.) Rounding to 12 bits per component is performed only at the final output. This allows full accuracy with correct rounding and overflow headroom for applications that require less than 12 bits per component. All inputs and outputs are registered on the rising edges of the clock.

The TMC2272 is fabricated in a one-micron CMOS process and has fully guaranteed performance over the full commercial temperature range of 0 to 70°C, and all other operational conditions specified in the *Operating Conditions* table. The TMC2272 is available in a 121-pin plastic pin-grid array (PPGA) package in three speed grades.

Logic Symbol

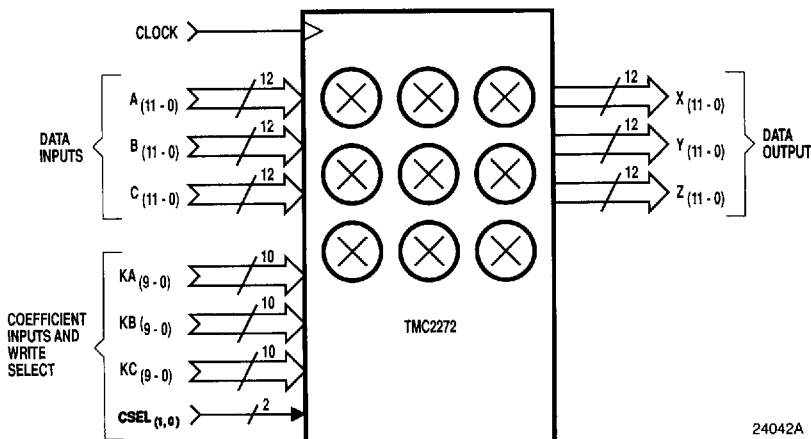

Features

- ◆ 40 MHz (25 ns) pipelined throughput
- ◆ 3 Simultaneous 12-bit input and output channels (64 Giga [2³⁶] colors)
- ◆ Two's complement inputs and outputs
- ◆ Overflow headroom available in lower resolution
- ◆ 10-bit user-defined coefficients
- ◆ TTL-compatible input and output signals
- ◆ Full precision internal calculation
- ◆ Output rounding
- ◆ On-board coefficient memory
- ◆ OMICRON-C™ 1 μ CMOS process

Associated Products

- ◆ TDC1058 A/D Converter
- ◆ TDC1049 A/D Converter
- ◆ TMC2242 Interpolator/Decimator
- ◆ TMC2230 Rectangular/Polar Converter
- ◆ TMC22X9X Digital Video Encoder
- ◆ TMC22071 Genlocking Video Digitizer

Applications

- ◆ Translation between component color standards (RGB, YIQ, YUV, etc.)
- ◆ Broadcast composite color encoding and decoding (all standards)
- ◆ Broadcast composite color standards conversion and transcoding
- ◆ Camera tube and monitor phosphor colorimetry correction
- ◆ White balancing and color-temperature conversion
- ◆ Image capture, processing and storage
- ◆ Color matching between systems, cameras and monitors
- ◆ Three-dimensional perspective translation

Figure 1. Functional Block Diagram

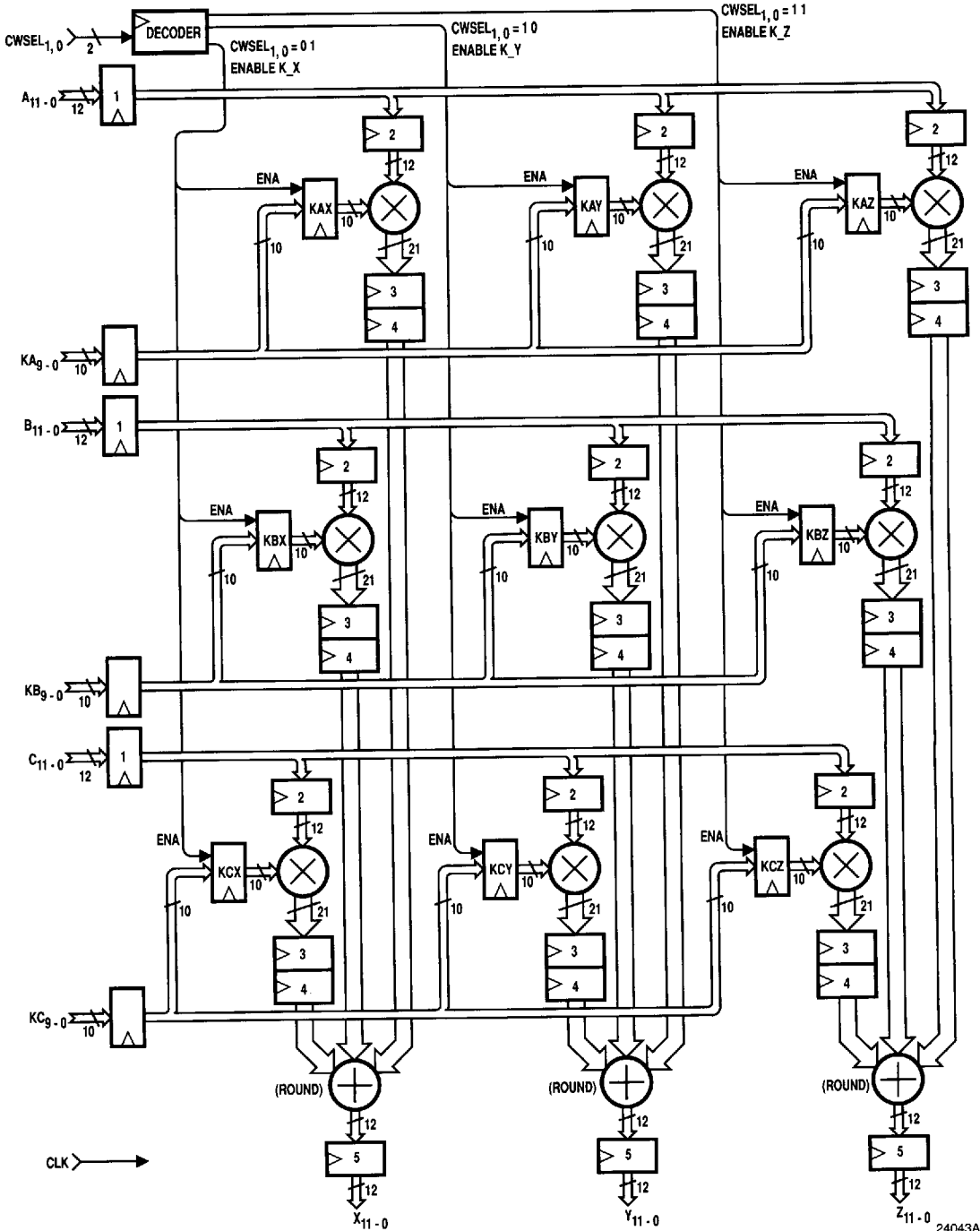

Multimedia

24043A

Functional Description

General Information

The TMC2272 is a nine-multiplier array with the internal bus structure and summing adders needed to implement a 3 x 3 matrix multiplier (triple dot product). With a 40MHz guaranteed maximum clock rate, this device offers video and imaging system designers a single-chip solution to numerous common image and signal-processing problems.

The three data input ports (A₁₁₋₀, B₁₁₋₀, C₁₁₋₀) accept 12-bit two's complement integer data, which is also the format for the output ports (X₁₁₋₀, Y₁₁₋₀, and Z₁₁₋₀). Other format and path width options are discussed in the numeric format and overflow section. The coefficient input ports (KA, KB, KC) are always 10-bit two's complement fractional. *Table 2* details the bit weighting.

Full precision is maintained throughout the TMC2272. Each output is accurately rounded to 12 bits from the 23 bits entering the final adder.

Signal Definitions

- A(n), B(n), C(n) Indicates the data word presented to that input port during the specified clock rising edge (n). Applies to input ports A₁₁₋₀, B₁₁₋₀, and C₁₁₋₀.
- KAX(n) thru KCZ(n) Indicates coefficient value stored in the specified one of the nine onboard coefficient registers KAX through KCZ, input during or before the specified clock rising edge (n).
- X(n), Y(n), Z(n) Indicates data available at that output port t_{DQ} after the specified clock rising edge (n). Applies to output ports X₁₁₋₀, Y₁₁₋₀, and Z₁₁₋₀.

The TMC2272 utilizes six input and output ports to realize a "triple dot product," in which each output is the sum of all three input words in multiplied by the appropriate stored coefficients. The three corresponding sums of products are available at the outputs five clock cycles after the input data are latched, and three new data words rounded to 12-bits are then available every clock cycle. See the

Applications Discussion regarding encoded video standard conversion matrices.

$$X(5) = A(1)KAX(1) + B(1)KBX(1) + C(1)KCX(1)$$

$$Y(5) = A(1)KAY(1) + B(1)KBY(1) + C(1)KCY(1)$$

$$Z(5) = A(1)KAZ(1) + B(1)KBZ(1) + C(1)KCZ(1)$$

Pin Definitions

Power

V_{DD}, GND The TMC2272 operates from a single +5V supply. All pins must be connected.

Control

CWSEL₁₋₀ This input selects which three of the 9 coefficient registers, if any, will be updated on the next clock cycle from the KA₉₋₀, KB₉₋₀ and KC₉₋₀ inputs. See *Table 4* and the *Functional Block Diagram*.

Clock

CLK The TMC2272 operates from a single system clock input. All timing specifications are referenced to the rising edge of clock.

Data and Coefficient Inputs

- A₁₁₋₀, B₁₁₋₀, C₁₁₋₀ These are the three 12-bit wide data input ports.
- KA₉₋₀, KB₉₋₀, KC₉₋₀ These are the 10-bit wide coefficient input ports. The value at each of these three inputs will update one coefficient register as selected by the coefficient write select (CWSEL₁₋₀) on the next clock. See *Table 1* and the *Functional Block Diagram*.

Outputs

X₁₁₋₀, Y₁₁₋₀, Z₁₁₋₀ These are the data outputs. Data are available at the 12-bit registered Output Ports X, Y, and Z t_{DQ} after every clock rising edge.

RAYTHEON/ SEMICONDUCTOR

Table 1. Coefficient Loading

		CWSEL _{1,0}			
		00	01	10	11
Input	KAg-0	Hold All	Load KAX	Load KAY	Load KAZ
Input	KBg-0	Hold All	Load KBX	Load KBY	Load KBZ
Input	KCg-0	Hold All	Load KCX	Load KCY	Load KCZ

Package Interconnections

Signal Type	Signal Name	Function	H5 Package
Power	VDD	Supply Voltage	F3, H3, L7, C8, C4
	GND	Ground	E3, G3, J3, L4, L6, H11, C7, C5, A4, B5
Clock	CLK	System Clock	D11
Controls	CWSEL _{1,0}	Coefficient Write Select	J12, J13
Inputs	A ₁₁₋₀	Data Input A	E11, D13, E12, E13, F11, F12, F13, G13, G11, G12, H13, H12
	B ₁₁₋₀	Data Input B	B10, A11, B11, C10, A12, B12, C11, A13, C12, B13, C13, D12
	C ₁₁₋₀	Data Input C	A5, C6, B6, A6, A7, B7, A8, B8, A9, B9, A10, C9
	KAg-0	Coefficient Input KAX, KAY, or KAZ (See Pin Definitions and Table 1)	K13, J11, K12, L13, L12, K11, M13, M12, L11, N13
	KBg-0	Coefficient Input KBX, KBY, or KBZ (See Pin Definitions and Table 1)	M11, L10, N12, N11, M10, L9, N10, M9, N9, L8
	KCg-0	Coefficient Input KCX, KCY, or KCZ (See Pin Definitions and Table 1)	M8, N8, N7, M7, N6, M6, N5, M5, N4, L5
Outputs	X ₁₁₋₀	Output X	B4, A3, A2, B3, A1, C3, B2, B1, D3, C2, C1, D2
	Y ₁₁₋₀	Output Y	D1, E2, E1, F2, F1, G2, G1, H1, K1, J2, J1, H2
	Z ₁₁₋₀	Output Z	M4, N3, M3, N2, M2, L3, N1, L2, K3, M1, L1, K2

Multimedia

Figure 2. Impulse Response

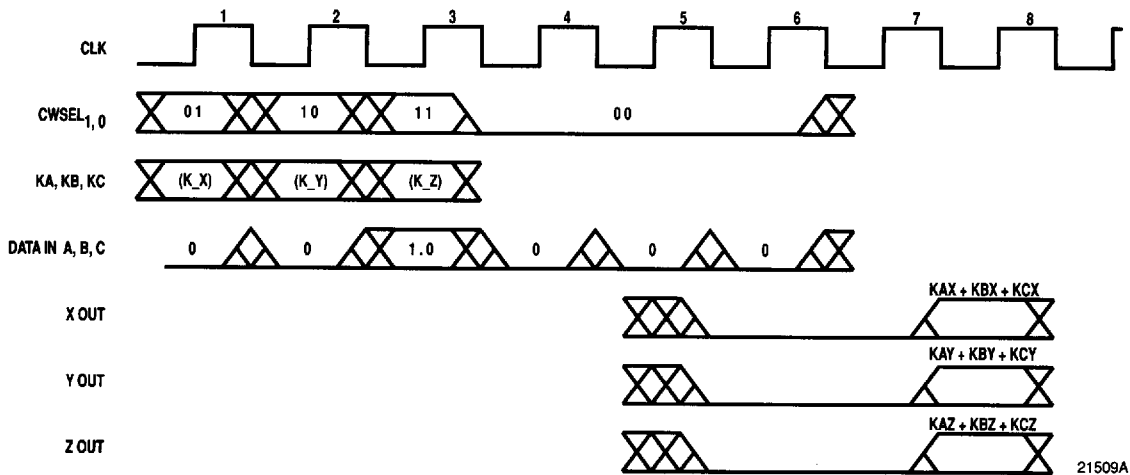

21509A

Figure 3. Input/Output Timing Diagram

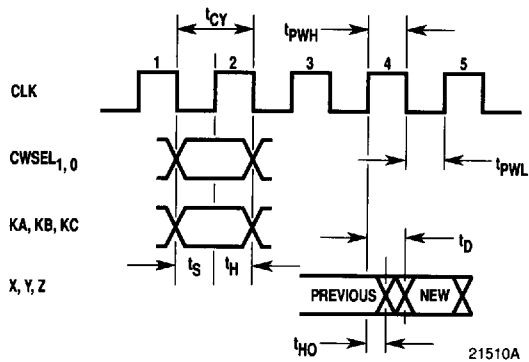

21510A

— RAYTHEON/ SEMICONDUCTOR

Numeric Format and Overflow

Table 2 shows the binary weightings of the input and output ports of the TMC2272. Although the internal sums of products could grow to 23-bits, the outputs X, Y, and Z are rounded to yield 12-bit integer words. Thus the output format is identical to the input data format. Bit weighting is easily adjusted by applying the same scaling correction factor to both input and output data words.

As shown in *Table 2*, the TMC2272's matched input and output data formats accommodate 0dB (unity) gain. Therefore the user must be aware of input conditions that could lead to numeric overflow. Maximum input data and coefficient word sizes must be taken into account with the specific translation performed to ensure that no overflow occurs.

Use with Fewer Than 12 Bits

The TMC2272 can be configured to provide several format and overflow options when used in systems with fewer than 12-bits of resolution. An 8-bit system will be used as an example, however these concepts apply to any other word width.

The most apparent mode of operation is to left justify the incoming data and to ground the unused input LSBs. However, the outputs will still be rounded to the least significant bit of the TMC2272, having little if any effect on the top 8 bits actually used. Because the TMC2272 carries out all calculations to full precision, the preferred mode of operation is to right justify and sign extend the data as shown in *Figure 4*. Since all the LSBs are used, the desired output will be rounded correctly, and overflow will be accommodated by bits 7 through 10.

The TMC2272 may also be used in unsigned binary 8-bit systems as shown in *Figure 5*. Bits 11 through 8 will handle overflow.

In all applications, a digital zero (ground) should be connected to all unused inputs.

Table 2. Bit Weightings for Input and Output Data Words

Bit Weights	2 ¹¹	2 ¹⁰	2 ⁹	2 ⁸	2 ⁷	2 ⁶	2 ⁵	2 ⁴	2 ³	2 ²	2 ¹	2 ⁰	.	2 ⁻¹	2 ⁻²	2 ⁻³	2 ⁻⁴	2 ⁻⁵	2 ⁻⁶	2 ⁻⁷	2 ⁻⁸	2 ⁻⁹	
INPUTS																							
All Modes																							
Data A, B, C	-1 ₁₁	1 ₁₀	1 ₉	1 ₈	1 ₇	1 ₆	1 ₅	1 ₄	1 ₃	1 ₂	1 ₁	1 ₀	.										
Coefficients KA, KB, KC													-K ₉	.	K ₈	K ₇	K ₆	K ₅	K ₄	K ₃	K ₂	K ₁	K ₀
Internal Sum	-X ₂₀	X ₁₉	X ₁₈	X ₁₇	X ₁₆	X ₁₅	X ₁₄	X ₁₃	X ₁₂	X ₁₁	X ₁₀	X ₉	.	X ₈	X ₇	X ₆	X ₅	X ₄	X ₃	X ₂	X ₁	X ₀	
OUTPUTS																							
X, Y, Z	-0 ₁₁	0 ₁₀	0 ₉	0 ₈	0 ₇	0 ₆	0 ₅	0 ₄	0 ₃	0 ₂	0 ₁	0 ₀	.										

Note: A minus sign indicates a two's complement sign bit.

Multimedia

Figure 4. Two's Complement 8-Bit Application

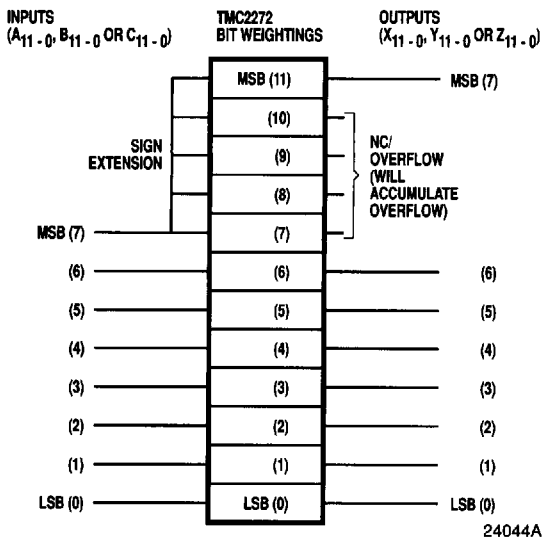
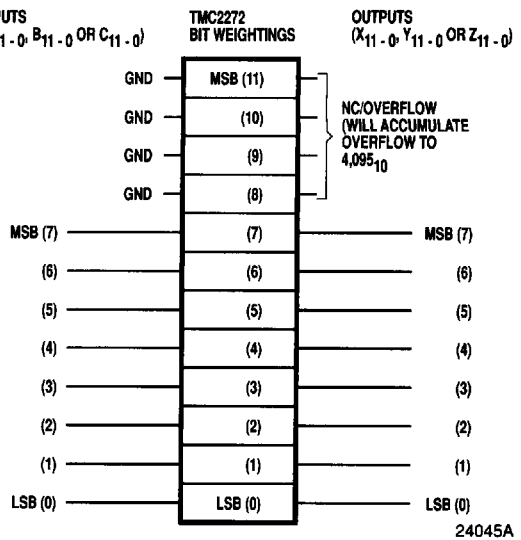

Figure 5. Binary 8-Bit Application



Absolute maximum ratings (beyond which the device may be damaged)¹

Supply Voltage	-0.5 to +7.0V
Input Voltage	-0.5 to (V _{DD} + 0.5)V
Output	
Applied voltage	-0.5 to (V _{DD} + 0.5)V ²
Forced current	-6.0 to 6.0mA ^{3,4}
Short-circuit duration (single output in HIGH state to ground)	1 sec
Temperature	
Operating case	-60 to +130°C
junction	175°C
Lead soldering (10 seconds)	300°C
Storage	-65 to 150°C

- Notes:
1. Absolute maximum ratings are limiting values applied individually while all other parameters are within specified operating conditions. Functional operation under any of these conditions is NOT implied.
 2. Applied voltage must be current limited to specified range, and measured with respect to GND.
 3. Forcing voltage must be limited to specified range.
 4. Current is specified as conventional current flowing into the device.

RAYTHEON/ SEMICONDUCTOR

Operating conditions

Parameter		Temperature Range			Units	
		Standard				
		Min	Nom	Max		
V _{DD}	Supply Voltage	4.75	5.0	5.25	V	
V _{IL}	Input Voltage, Logic LOW			0.8	V	
V _{IH}	Input Voltage, Logic HIGH	2.0			V	
I _{OL}	Output Current, Logic LOW			4.0	mA	
I _{OH}	Output Current, Logic HIGH			-2.0	mA	
t _{CY}	Cycle Time					
		TMC2272	33			ns
		TMC2272-1	27.7			ns
		TMC2272-2	25			ns
t _{PWL}	Clock Pulse Width, LOW					
		TMC2272	15			ns
		TMC2272-1	12			ns
		TMC2272-2	10			ns
t _{PWH}	Clock Pulse Width, HIGH	10			ns	
t _S	Input Setup Time					
		TMC2272	8			ns
		TMC2272-1	7			ns
		TMC2272-2	6			ns
t _H	Input Hold Time					
		TMC2272	3			ns
		TMC2272-1	3			ns
		TMC2272-2	2			ns
T _A	Ambient Temperature, Still Air	0		70	°C	

Electrical characteristics within specified operating conditions¹

Parameter	Test Conditions	Temperature Range		Units	
		Standard			
		Min	Max		
I _{DDQ}	Supply Current, Quiescent	V _{DD} =Max, V _{IN} =0V		12	mA
I _{DDU}	Supply Current, Unloaded	V _{DD} =Max, f=20MHz		160	mA
I _{IL}	Input Current, Logic LOW ²	V _{DD} =Max, V _{IN} =0V		±10	µA
I _{IH}	Input Current, Logic HIGH ²	V _{DD} =Max, V _{IN} =V _{DD}		±10	µA
I _{OZL}	Leakage Current, Logic LOW ³	V _{DD} =Max, V _{IN} =0V		±40	µA
I _{OZH}	Leakage Current, Logic HIGH ³	V _{DD} =Max, V _{IN} =V _{DD}		±40	µA
V _{OL}	Output Voltage, Logic LOW	V _{DD} =Min, I _{OL} =4mA		0.4	V
V _{OH}	Output Voltage, Logic HIGH	V _{DD} =Min, I _{OH} =-2mA	2.4		V
I _{OS}	Short-Circuit Output Current	V _{DD} =Max, Output HIGH, One Pin to Ground, One Second Duration Max.	-20	-80	mA
C _I	Input Capacitance	T _A =25°C, f=1MHz		10	pF
C _O	Output Capacitance	T _A =25°C, f=1MHz		10	pF

- Notes:
1. Actual test conditions may vary from those shown, but guarantee operation as specified.
 2. Except pins X₁₁₋₀, Y₁₁₋₀
 3. Pins X₁₁₋₀, Y₁₁₋₈ only.

Switching characteristics within specified operating conditions

Parameter	Test Conditions	Temperature Range		Units	
		Standard			
		Min	Max		
t _D Output Delay	V _{DD} =Min, C _{LOAD} =25pF				
		TMC2272		18	ns
		TMC2272-1		17	ns
TMC2272-2			16	ns	
t _{HQ} Output Hold Time	V _{DD} =Max, C _{LOAD} =25pF				
		TMC2272	3		ns
		TMC2272-1	3		ns
TMC2272-2	3		ns		

RAYTHEON/ SEMICONDUCTOR

Figure 6. Equivalent Input Circuit

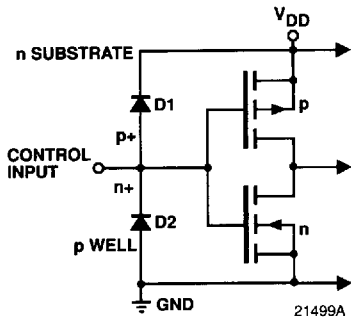
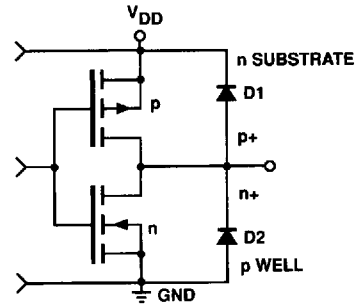

Figure 7. Equivalent Output Circuit



Applications Discussion

The TMC2272 can convert between any two three-coordinate colorspaces with the selection of the proper coefficients. Sets of coefficients for some popular colorspace conversions are presented below.

By concatenating coefficient matrices of single transformations, the user can program the TMC2272 to perform compound transforms efficiently. For example, given an RGB input, correction of the relative values of R and B, for color temperature, conversion to YIQ,

modification of contrast by changing Y, and conversion back to RGB can be performed as quickly and easily as any simple transformation. To calculate the final set of coefficients from the coefficients of the individual transformations, the procedure in *Figure 8* (concatenation) is used. If more than two matrices are to be combined, the result from the concatenation of the first two matrices is concatenated with the third. If more matrices must be incorporated in the final function, the last step is repeated.

Figure 8. Concatenation

$$\begin{vmatrix} A & B & C \\ D & E & F \\ G & H & I \end{vmatrix} \begin{vmatrix} J & K & L \\ M & N & O \\ P & Q & R \end{vmatrix} = \begin{vmatrix} AJ + BM + CP & AK + BN + CQ & AL + BO + CR \\ DJ + EM + FP & DK + EN + FQ & DL + EO + FR \\ GJ + HM + IP & GK + HN + IQ & GL + HO + IR \end{vmatrix}$$

24046A

Converting From GBR to YC_BC_R

With the right coefficients, two external NOT gates, and an external 4-bit half-addder, the TMC2272 can convert video data from 8-bit full-scale (e.g., VGA) GBR components to 10-bit YC_BC_R components.

Table 1. 10-bit component formats and inclusive ranges.

Color Space Term	Data Range	Format
Y Luminance	64-940	magnitude
Y' Y - 64	0-876	magnitud
C _B Color difference, Blue	64-960	magnitude
U' C _B - 512	+/-448	2's comp
C _R Color difference, Red	64-960	magnitude
V' C _R - 512	+/-448	2s comp
GBR Green, Blue, Red components	0-255	magnitude, 8-bits

The analog defining equations for 1 Volt luminance and +/-0.5 Volt color difference components are:

$$\begin{aligned}
 Y &= 0.5870 (G) + 0.1140 (B) + 0.2990 (R) \\
 B - Y &= -0.3313 (G) + 0.5000 (B) - 0.1687 (R) \\
 R - Y &= -0.4187 (G) - 0.0813 (B) + 0.5000 (R)
 \end{aligned}$$

To translate these equations into the digital domain, note that the ranges of R, G, and B are 0 to 255 instead of 0 to 1, the range of Y is 64 to 940 instead of 0 to 1, and the ranges of U and V are 64 to 960, instead of +/- 0.5:

$$\begin{aligned}
 Y &= (876/255)(0.587(G)+0.114(B)+0.299(R))+64 \\
 &= 2.01652 (G) + 0.39162 (B) + 1.02715 (R) + 64
 \end{aligned}$$

$$\begin{aligned}
 C_B &= (896/255)(-0.3313(G)+0.5(B)-0.1687(R))+512 \\
 &= -1.16397(G) + 1.75686(B) - 0.59289(R) + 512
 \end{aligned}$$

$$\begin{aligned}
 C_R &= (896/255)(-0.4187(G)-0.0813(B)+0.5(R))+512 \\
 &= -1.47115(G) - 0.28571(B) + 1.75686(B) + 512
 \end{aligned}$$

Let $Y' = Y - 64$, $U' = C_B - 512$, and $V' = C_R - 512$. The TMC2272 will compute Y' , U' , and V' . Adding 64 (040_h) externally to Y' will then yield Y , whereas inverting the most significant bits of U' and V' , $U'9$ and $V'9$, will yield C_B and C_R , respectively. Multiplying the equations immediately above by 128 and rounding each coefficient to the nearest integer yields the recommended set of coefficients for GBR to YUV conversion.

$$\begin{aligned}
 128 (Y') &= 258 (G) + 50 (B) + 131 (R) && \text{dec.} \\
 &102 \quad 032 \quad 083 && \text{hex} \\
 128 (U') &= -149 (G) + 225 (B) - 76 (R) && \text{dec.} \\
 &36B \quad 0E1 \quad 3B4 && \text{hex} \\
 128 (V') &= -188 (G) - 37 (B) + 225 (R) && \text{dec.} \\
 &344 \quad 3DB \quad 0E1 && \text{hex}
 \end{aligned}$$

If the TMC2272 input data alignment for 8-bit GBR is:

```

0 0 G7 G6 G5 G4 G3 G2 G1 G0 0 0
0 0 B7 B6 B5 B4 B3 B2 B1 B0 0 0
0 0 R7 R6 R5 R4 R3 R2 R1 R0 0 0
    
```

then the output data alignment for 10-bit Y'U'V' is:

```

0 0 Y9 Y8 Y7 Y6 Y5 Y4 Y3 Y2 Y1 Y0
U9 U9 U9 U8 U7 U6 U5 U4 U3 U2 U1 U0
V9 V9 V9 V8 V7 V6 V5 V4 V3 V2 V1 V0
    
```

where the tripled U₉ and V₉ sign bits denote two's complement sign extensions. The factors of 4 in the input data format and 128 in the equations are absorbed by the internal 9-bit (factor of 512) right-shifting of the emerging results.

At the output of the TMC2272, invert the most significant bits, U₉ and V₉, of the chrominance components, and add 1 at Y₆ of the luminance to obtain the true CCIR Rec. 601 values.

Converting from GBR to 8-bit Full-Scale YUV

With the right coefficients and two external NOT gates, the TMC2272 can convert video data from 8-bit full-scale (e.g., VGA) GBR components to 8-bit full-scale YUV components.

RAYTHEON/ SEMICONDUCTOR

Table 2. 8-bit component formats and inclusive ranges:

Color Space Term	Range	Format
Y Luminance	0-255	magnitude
U Color difference, Blue	128 to -127	2's comp
U' U + 128	0-255	magnitude
V Color difference, Red	128 to -127	2s comp
V' V + 128	0-255	magnitude
G,B,R Green, Blue, Red components	0-255	magnitude

As in the previous RGB to YC_BC_R case, begin with the defining equations, but without the range compensation factors of 255 / 876 and 255 / 896:

$$\begin{aligned}
 Y &= 0.5870 (G) + 0.1140 (B) + 0.2990 (R) \\
 U &= -0.3313 (G) + 0.5000 (B) - 0.1687 (R) \\
 V &= -0.4187 (G) - 0.0813 (B) + 0.5000 (R)
 \end{aligned}$$

The TMC2272 will compute Y, U, and V directly, whereas inverting the most significant bits of U and V (U7 and V7 will yield U' and V', respectively). Multiplying the equations immediately above by 512 and rounding each coefficient to the nearest integer yields the recommended set of coefficients for GBR to YUV conversion.

$$\begin{aligned}
 512 (Y) &= 301 (G) + 58 (B) + 153 (R) && \text{dec.} \\
 &12D \quad 03A \quad 099 && \text{hex} \\
 512 (U) &= -170 (G) + 256 (B) - 86 (R) && \text{dec.} \\
 &356 \quad 100 \quad 3AA && \text{hex} \\
 512 (V) &= -214 (G) - 42 (B) + 256 (R) && \text{dec.} \\
 &32A \quad 3D6 \quad 100 && \text{hex}
 \end{aligned}$$

If the TMC2272 input data alignment for 8-bit GBR is:

```

0 0 0 0 G7 G6 G5 G4 G3 G2 G1 G0
0 0 0 0 B7 B6 B5 B4 B3 B2 B1 B0
0 0 0 0 R7 R6 R5 R4 R3 R2 R1 R0
    
```

then the output data alignment for 8-bit YUV is:

```

0 0 0 0 y7 Y6 Y5 Y4 Y3 Y2 Y1 Y0
U7 U7 U7 U7 U7 U6 U5 U4 U3 U2 U1 U0
V7 V7 V7 V7 V7 V6 V5 V4 V3 V2 V1 V0
    
```

where the quintupled U9 and V9 sign bits denote two's complement sign extensions. The factor of 512 in the equations above is absorbed by the internal 9-bit right shift of each emerging result.

At the output of the TMC2272, invert the most significant bits, U7 and V7, of the chrominance components, to obtain the 8-bit offset format.

Converting From YC_BC_R to GBR

Following the notation employed earlier, the TMC2272 will be used to convert data in Y'U'V' format into GBR format.

Since Y' = 876, U' = V' = 0, and G = B = R = 255 for saturated white output, every "Y'" coefficient will be 255 / 876 = 0.29110. The full analog matrix for Y'U'V' to GBR conversion is:

$$\begin{aligned}
 G &= 0.29110 (Y') - 0.09794 (U') - 0.20324 (V') \\
 B &= 0.29110 (Y') + 0.50431 (U') \\
 R &= 0.29110 (Y') + 0.39901 (V')
 \end{aligned}$$

Since the largest element is just over 0.5 and the largest permissible coefficient is 511, multiply all elements of the matrix by 512 to obtain the values to load into the TMC2272:

$$\begin{aligned}
 G &= 149 (Y') - 50 (U') - 04 (V') && \text{dec.} \\
 &095 \quad 3CE \quad 398 && \text{hex} \\
 B &= 149 (Y') + 258 (U') && \text{dec.} \\
 &095 \quad 100 && \text{hex} \\
 R &= 149 (Y') + 204 (V') && \text{dec.} \\
 &095 \quad 0CC && \text{hex}
 \end{aligned}$$

Decrease the incoming luminance at the input to the TMC2272 by 64 by adding 1's at positions Y9, Y8, Y7, and Y6. Invert U9 and V9 and their sign extensions, to accommodate CCIR Rec. 601 data. Instead of reducing Y by 64, an alternate is to reduce each of the G, B, and R outputs by (255) (64 / 876) = 19.

For the Y'U'V' to RGB conversion, the TMC2272 input data alignment for 10-bit Y'U'V' is:

```

0 0 Y9 Y8 Y7 Y6 Y5 Y4 Y3 Y2 Y1 Y0
U9 U9 U9 U8 U7 U6 U5 U4 U3 U2 U1 U0
V9 V9 V9 V8 V7 V6 V5 V4 V3 V2 V1 V0
    
```

where the tripled U9 and V9 sign bits denote two's complement sign extensions. The TMC2272 output data alignment for 8-bit GBR is then:

```

0 0 0 0 G7 G6 G5 G4 G3 G2 G1 G0
0 0 0 0 B7 B6 B5 B4 B3 B2 B1 B0
0 0 0 0 R7 R6 R5 R4 R3 R2 R1 R0
    
```

```

G = 256 (Y') -88 (U') -83 (V')    dec.
    100    3A8    349                hex
B = 256 (Y') +454 (U')            dec.
    100    1C6                hex
R = 256 (Y') +359 (V')            dec.
    100    167                hex
    
```

Converting From 8-bit Full Scale YUV to GBR

Following the notation employed earlier, the TMC2272 will be used to convert data in 8-bit YUV format into 8-bit GBR format.

Since $Y = 256$, $U = V = 0$, and $G = B = R = 255$ for saturated white output, every "Y" coefficient will be $255 / 256 = 1.0$. The full matrix for YUV to GBR conversion is:

```

G = 1.0 (Y) -0.3443 (U) -0.7142 (V)
B = 1.0 (Y) +1.7727 (U)
R = 1.0 (Y) +1.3965 (V)
    
```

Since the largest element is over 1.0 and the largest permissible coefficient is 511, multiply all elements of the matrix by 256 to obtain the values to load into the TMC2272:

For the YUV to RGB conversion, the TMC2272 input data alignment for 10-bit Y'U'V' is:

```

0 Y9 Y8 Y7 Y6 Y5 Y4 Y3 Y2 Y1 Y0 0
U9 U8 U7 U6 U5 U4 U3 U2 U1 U0 0
V9 V8 V7 V6 V5 V4 V3 V2 V1 V0 0
    
```

where the doubled U9 and V9 sign bits denote two's complement sign extensions. The TMC2272 output data alignment for 8-bit GBR is then:

```

0 0 0 0 G7 G6 G5 G4 G3 G2 G1 G0
0 0 0 0 B7 B6 B5 B4 B3 B2 B1 B0
0 0 0 0 R7 R6 R5 R4 R3 R2 R1 R0
    
```

Note that the inputs have to be doubled because the coefficient gain is 256, whereas the internal gain is $1 / 512$, for a net gain of $1/2$.

Table 3. Summary of Colorspace Conversion Coefficients

Conversion	KAX KAY KAZ	KBX KBY KBZ	KCX KCY KCZ
RGB to YUV	099 3AA 100	12D 356 32A	03A 100 3D6
RGB to YCbCr	083 3B4 0E1	102 36B 344	032 0E1 3DB
YUV to RGB	100 100 100	000 3A8 1C6	167 349 000
YCbCr to RGB	149 149 149	000 3CE 102	0CC 398 000

Table 4. Conversion Port Assignments and Alignments

Port	AIN	BIN	CIN	XOUT	YOUT	ZOUT
RGB to YUV	R7-0	G7-0	B7-0	Y7-0	U7-0 (e)	V7-0 (e)
RGB to YCbCr	R7-0	G7-0	B7-0	Y9-0	U9-0 (e)	V9-0 (e)
YUV to RGB	Y8-1 (e)	U8-1 (e)	V8-1 (e)	R7-0	G7-0	B7-0
YCbCr to RGB	Y9-0	CB9-0 (e)	CR9-0 (e)	R7-0	G7-0	B7-0

where XY-0 denotes right-justified, (e) denotes sign extension, and XY-1 denotes shifted one bit leftward from right-justified position.

RAYTHEON/ SEMICONDUCTOR

HSV (HSI) Format Conversions

HSV (or HSI) refers to Hue (color) Saturation (vividness) and Value (intensity or brightness), quantities which are directly related to the human perception of light and color. The V (or I) levels are simply the Y (or luminance) levels. Hue and Saturation are derived from the R-Y and B-Y color difference values of a signal.

HSV Calculations:

Value (V) = Intensity (I) = Y

Hue (H) = Arctan (B-Y/R-Y)

Saturation (S) = $\sqrt{(R-Y)^2 + (B-Y)^2}$

R-Y = S * cos(H)

B-Y = S * sin(H)

One may use two 64Kx8 ROM look-up-tables to calculate Hue and Saturation from R-Y and B-Y in an 8-bit system. However, the finite size of this LUT may limit performance, especially if the TMC2272's full precision is used. The TMC2330, developed to translate between rectangular and polar coordinates, can perform the trigonometric transformations to 16 bit precision at 25MHz. These calculations are the same as required in HSV calculations. A 4 Giga-byte x 32 bit LUT can achieve the same accuracy and precision as the TMC2330, if it is programmed correctly.

To convert between Y, R-Y, B-Y and HSV, the the TMC2272 isn't needed at all; simply use the TMC2330. To convert between HSV and any other format, use the TMC2330 to translate between HSV and Y, R-Y, B-Y, and use the TMC2272 to translate between Y, R-Y, B-Y and the other format. See Figures 9 and 10.

Figure 9. Conversion to HSV

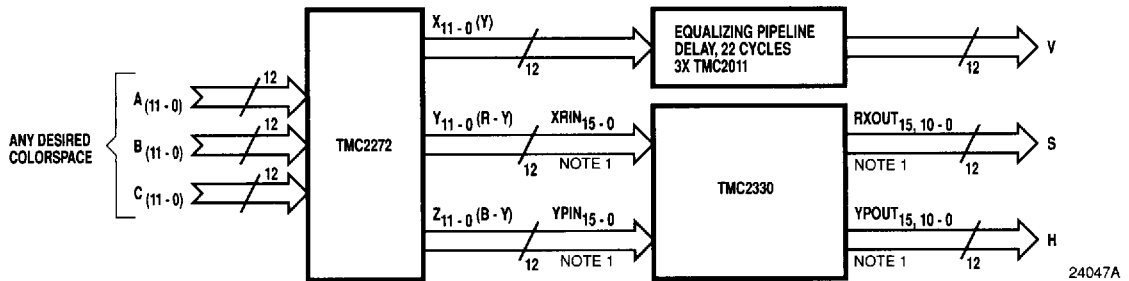

- Notes: 1. Connect TMC2272 MSBs (Bits 11) to TMC 2330 MSBs (Bits 15) and also to TMC2330 Bits 14-11. Connect TMC2272 LSBs (Bits 10-0) to TMC2330 LSBs (Bits 10-0). TMC2330 output bits 14-11 are overflow.
 2. TMC2272 Y₁₁₋₀ outputs should not be confused with the designation "Y" used to signify the intensity components. The assignment of components to TMC2272 inputs and outputs may be altered through the selection of appropriate coefficients.

Figure 10. Conversion from HSV

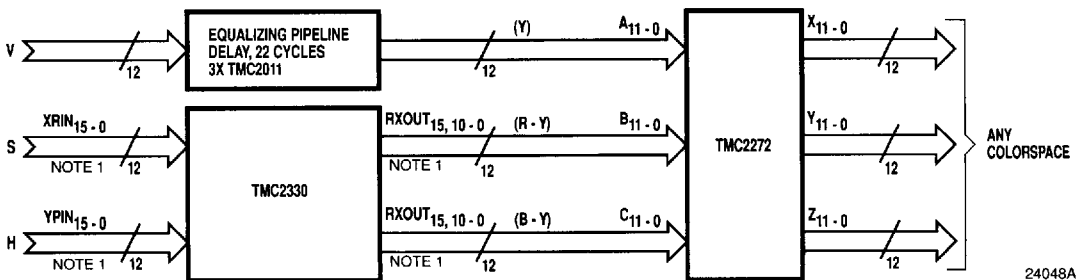

- Notes: 1. Connect input MSBs (Bits 11) to TMC2330 MSBs (Bits 15) and also to TMC2330 Bits 14-11. Connect input LSBs (Bits 10-0) to TMC2330 LSBs (Bits 10-0).
 2. TMC2272 Y₁₁₋₀ outputs should not be confused with the designation "Y" used for an intensity component. Component assignment depends on the coefficients used.

Input Interpolation/Output Decimation and Filtering

In some applications the two color-difference signals (R-Y/B-Y or Cr/Cb, for example,) are transmitted at one-half the rate of the luminance (Y) signal. These two color-difference signals are often multiplexed to one signal which is at the same sample rate as the luminance signal. In many applications, if the color difference signals are already band-limited, it is satisfactory to use the same color difference sample for each two luminance samples. Little improvement is obtained with a simple averaging ((A+B)/2) interpolation filter. If the color difference signal is not band-limited, either of these two methods may yield unsatisfactory results due to aliasing. In this case, a TRW TMC2242 digital low-pass ("half-band") interpolating filter will correctly band-limit each color difference signal as it is interpolated. See *Figure 11*.

The same methods are used to decimate the color difference outputs. Simple decimation by removing every other sample of color information may yield unsatisfactory results due to aliasing. This is a problem because the color difference signals have now been transformed with the higher-bandwidth luminance signals and therefore have higher bandwidths than they had before the transform. The best performance is obtained by using a precise low-pass ("half-band") decimation filter such as the TDC2242 to remove aliasing components. See *Figure 12*.

The TMC2242 is a bi-directional, selectable rate filter/interpolator/decimator

Figure 11. Input Interpolation and Filtering

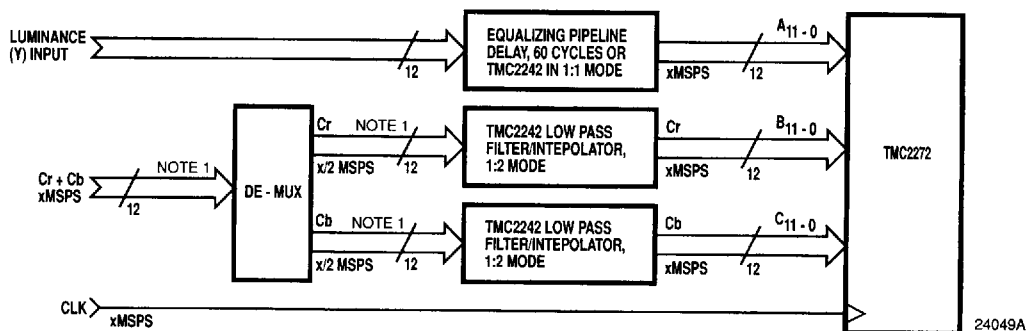

- Notes: 1. Width of input paths will vary with source.
2. See TMC2242 Datasheet for further information.

Figure 12. Output Decimation and Filtering

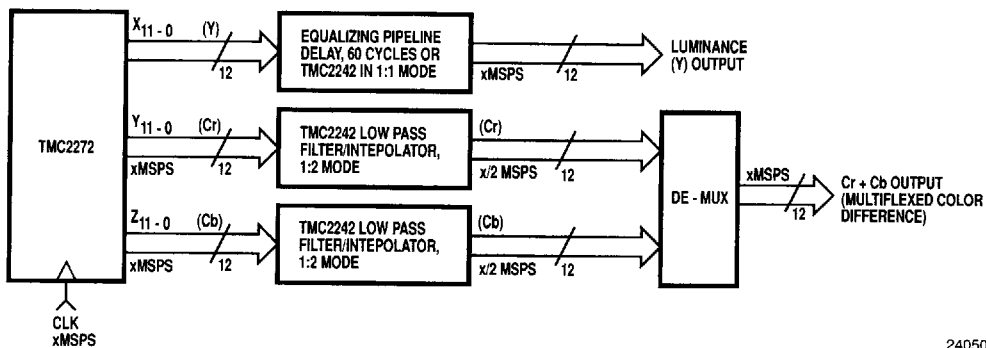

RAYTHEON/ SEMICONDUCTOR

Pin Assignments – 121-Pin Plastic Pin Grid Array H5 Package

Pin	Name	Pin	Name	Pin	Name	Pin	Name	Pin	Name	Pin	Name	Pin	Name
A1	X7	B5	GND	C9	C0	F1	Y7	H13	A1	L5	KC0	M9	KB2
A2	X9	B6	C9	C10	B8	F2	Y8	J1	Y1	L6	GND	M10	KB5
A3	X10	B7	C6	C11	B5	F3	VDD	J2	Y2	L7	VDD	M11	KB9
A4	GND	B8	C4	C12	B3	F11	A7	J3	GND	L8	KB0	M12	KA2
A5	C11	B9	C2	C13	B1	F12	A6	J11	KA8	L9	KB4	M13	KA3
A6	C8	B10	B11	D1	Y11	F13	A5	J12	CWSEL1	L10	KB8	N1	Z5
A7	C7	B11	B9	D2	X0	G1	Y5	J13	CWSEL0	L11	KA1	N2	Z8
A8	C5	B12	B6	D3	X3	G2	Y6	K1	Y3	L12	KA5	N3	Z10
A9	C3	B13	B2	D11	CLK	G3	GND	K2	Z0	L13	KA6	N4	KC1
A10	C1	C1	X1	D12	B0	G11	A3	K3	Z3	M1	Z2	N5	KC3
A11	B10	C2	X2	D13	A10	G12	A2	K11	KA4	M2	Z7	N6	KC5
A12	B7	C3	X6	E1	Y9	G13	A4	K12	KA7	M3	Z9	N7	KC7
A13	B4	C4	VDD	E2	Y10	H1	Y4	K13	KA9	M4	Z11	N8	KC8
B1	X4	C5	GND	E3	GND	H2	Y0	L1	Z1	M5	KC2	N9	KB1
B2	X5	C6	C10	E11	A11	H3	VDD	L2	Z4	M6	KC4	N10	KB3
B3	X8	C7	GND	E12	A9	H11	GND	L3	Z6	M7	KC6	N11	KB6
B4	X11	C8	VDD	E13	A8	H12	A0	L4	GND	M8	KC9	N12	KB7
												N13	KA0

Note: Pin D4 has no electrical connection. It is a mechanical orientation pin.

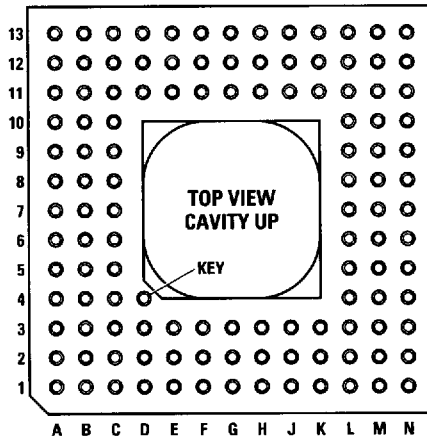

21041A

Multimedia

RAYTHEON/ SEMICONDUCTOR**Ordering Information**

Product Number	Speed MHz	Temperature Range	Screening	Package	Package Marking
TMC2272H5C	30	STD-TA = 0°C to 70°C	Commercial	121 Pin Plastic PGA	2272H5C
TMC2272H5C-1	36	STD-TA = 0°C to 70°C	Commercial	121 Pin Plastic PGA	2272H5C-1
TMC2272H5C-2	40	STD-T _A = 0°C to 70°C	Commercial	121 Pin Plastic PGA	2272H5C-2