

FEATURES

- ▶ SMD Package with Industry Standard Pinout
- ▶ Small Footprint:
 - 11.0 x 13.7 mm (0.43"x 0.54") Single Output Models
 - 11.0 x 16.3 mm (0.43"x 0.64") Dual Output Models
- ▶ I/O-Isolation 1500 VDC
- ▶ Single and Dual Output Models
- ▶ Operating Temp. Range -40°C to +85°C
- ▶ High Accuracy of Pin Planarity
- ▶ Qualified for lead-free reflow solder process according IPC/JEDEC J-STD-020D
- ▶ Tape & Reel Package available
- ▶ 3 Year Product Warranty

PRODUCT OVERVIEW

The MINMAX MSLU100 series is a range of 1W DC/DC converters in a SMD- Package featuring I/O-isolation of 1500VDC. The very small footprint makes this product the ideal solution for many applications where a voltage has to be isolated i.e for noise reduction, ground loop elimination, in digital interfaces or where a converted voltage is required.

An excellent efficiency allows an operating temperature range of -40°C to +85°C. with a new package design these converters are fully qualified for the higher temperature profile used in lead-free reflow solder processes. For automated SMD production lines the product can be supplied in tape& reel package.

Model Selection Guide

Model Number	Input Voltage (Range) VDC	Output Voltage VDC	Output Current		Input Current		Load Regulation % (max.)	Max. capacitive Load μ F	Efficiency (typ.)			
			Max. mA	Min. mA	@Max. Load mA(typ.)	@No Load mA(typ.)						
											@Max. Load %	
MSLU101	5 (4.5 ~ 5.5)	3.3	300	6	271	30	10	33	73			
MSLU102		5	200	4	256		10		78			
MSLU103		9	110	2	254		10		78			
MSLU104		12	84	1.5	259		8		78			
MSLU105		15	67	1	254		7		79			
MSLU106		± 5	± 100	± 2	270		10		74			
MSLU108		± 12	± 42	± 0.8	259		8		78			
MSLU109		± 15	± 33	± 0.7	254		7		78			
MSLU111		12 (10.8 ~ 13.2)	3.3	300	6		112		15	8	33	74
MSLU112			5	200	4		109			8		76
MSLU113	9		110	2	106	8	78					
MSLU114	12		84	1.5	106	5	79					
MSLU115	15		67	1	105	5	80					
MSLU116	± 5		± 100	± 2	113	8	74					
MSLU118	± 12		± 42	± 0.8	108	5	78					
MSLU119	± 15		± 33	± 0.7	104	5	79					
MSLU154	15 (13.5 ~ 16.5)		12	84	1.5	86	14	5		33		78
MSLU155			15	67	1	86		5				78
MSLU121	24 (21.6 ~ 26.4)	3.3	300	6	58	8	8	33	72			
MSLU122		5	200	4	54		8		78			
MSLU123		9	110	2	54		8		77			
MSLU124		12	84	1.5	55		5		77			
MSLU125		15	67	1	53		5		79			
MSLU126		± 5	± 100	± 2	57		9		8	33#	73	
MSLU128		± 12	± 42	± 0.8	54				5		78	
MSLU129		± 15	± 33	± 0.7	53				5		78	

For each output

Input Specifications					
Parameter	Model	Min.	Typ.	Max.	Unit
Input Voltage Range	5V Input Models	4.5	5	5.5	VDC
	12V Input Models	10.8	12	13.2	
	15V Input Models	13.5	15	16.5	
	24V Input Models	21.6	24	26.4	
Input Surge Voltage (1 sec. max.)	5V Input Models	-0.7	---	9	
	12V Input Models	-0.7	---	18	
	15V Input Models	-0.7	---	20	
	24V Input Models	-0.7	---	30	
Reverse Polarity Input Current	All Models	---	---	0.3	A
Internal Filter Type		Internal Capacitor			
Internal Power Dissipation		---	---	450	mW

Output Specifications					
Parameter	Conditions	Min.	Typ.	Max.	Unit
Output Voltage Balance	Dual Output, Balanced Loads	---	±0.1	±1.0	%
Line Regulation	For Vin Change of 1%	---	±1.2	±1.5	%
Load Regulation	Io=20% to 100%	See Model Selection Guide			
Ripple & Noise	max. 20MHz Bandwidth	---	---	120	mV _{P-P}
Temperature Coefficient		---	±0.01	±0.02	%/°C
Short Circuit Protection		0.5 Second Max.			

General Specifications					
Parameter	Conditions	Min.	Typ.	Max.	Unit
I/O Isolation Voltage (rated)	60 Seconds	1500	---	---	VDC
I/O Isolation Resistance	500 VDC	1000	---	---	MΩ
I/O Isolation Capacitance	100KHz, 1V	---	40	100	pF
Switching Frequency		50	100	140	KHz
MTBF (calculated)	MIL-HDBK-217F@25°C, Ground Benign	2,000,000	---	---	Hours
Moisture Sensitivity Level (MSL)	IPC/JEDEC J-STD-020D	Level 2			

Input Fuse			
5V Input Models	12V Input Models	15V Input Models	24V Input Models
500mA Slow-Blow Type	200mA Slow-Blow Type	150mA Slow-Blow Type	100mA Slow-Blow Type

Environmental Specifications					
Parameter	Conditions	Min.	Max.	Unit	
Operating Ambient Temperature Range (See Power Derating Curve)	Natural Convection	-40	+85	°C	
Case Temperature		---	+90	°C	
Storage Temperature Range		-50	+125	°C	
Humidity (non condensing)		---	95	% rel. H	
Cooling	Free-Air convection				
Lead Temperature (1.5mm from case for 10Sec.)		---	260	°C	

Output Voltage Tolerance

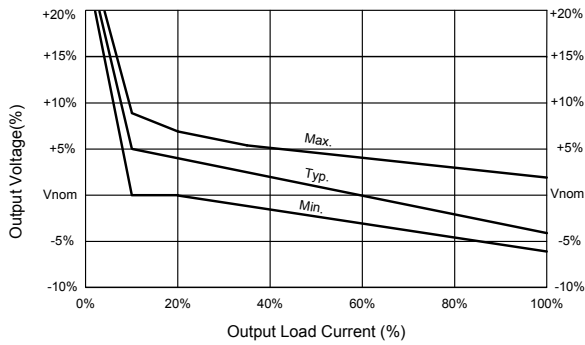

(3.3V & 5V Output)

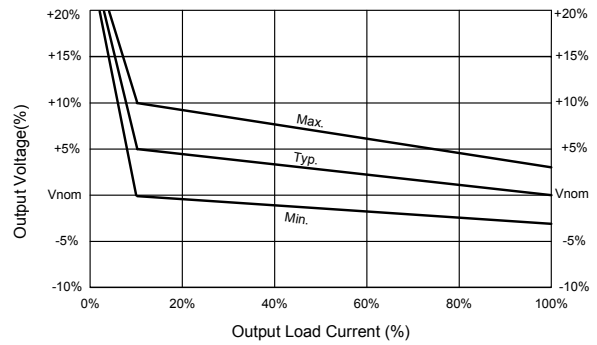

(All other Output)

Power Derating Curve

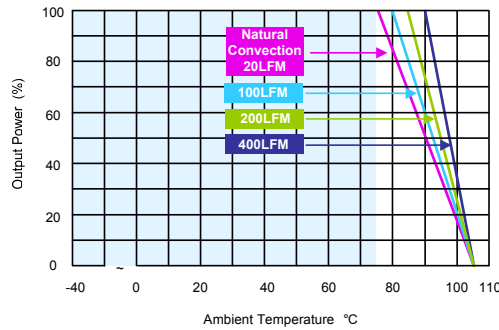

Notes

- 1 Specifications typical at $T_a=+25^{\circ}\text{C}$, resistive load, nominal input voltage and rated output current unless otherwise noted.
- 2 These power converters require a minimum output loading to maintain specified regulation, operation under no-load conditions will not damage these modules; however they may not meet all specifications listed.
- 3 All DC/DC converters should be externally fused at the front end for protection.
- 4 Other input and output voltage may be available, please contact factory.
- 5 That "natural convection" is about 20LFM but is not equal to still air (0 LFM).
- 6 It is not recommended to use water-washing process on SMT units.
- 7 Specifications are subject to change without notice.

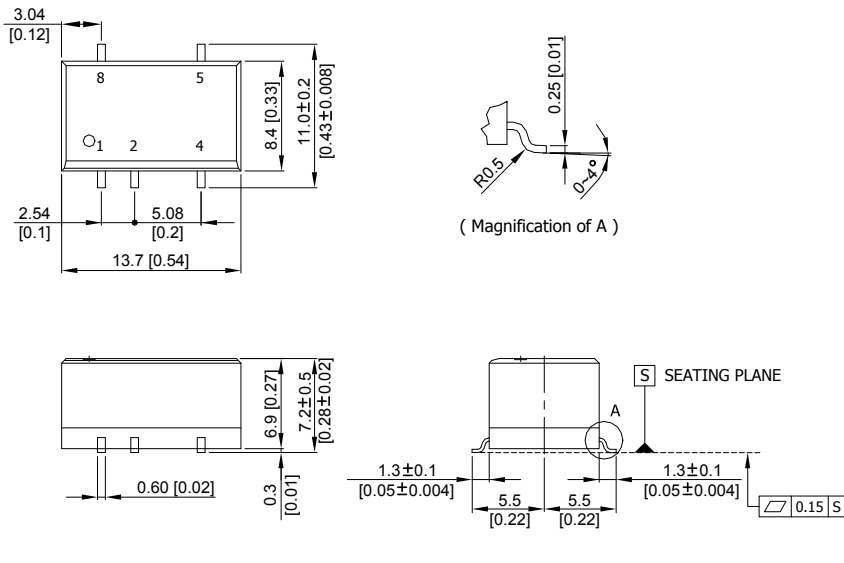
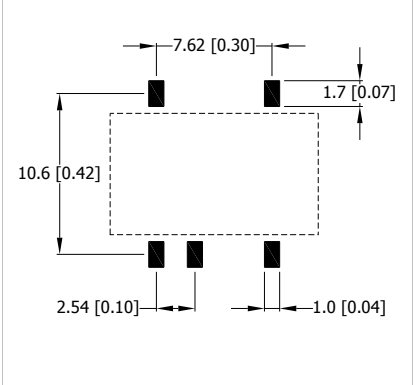
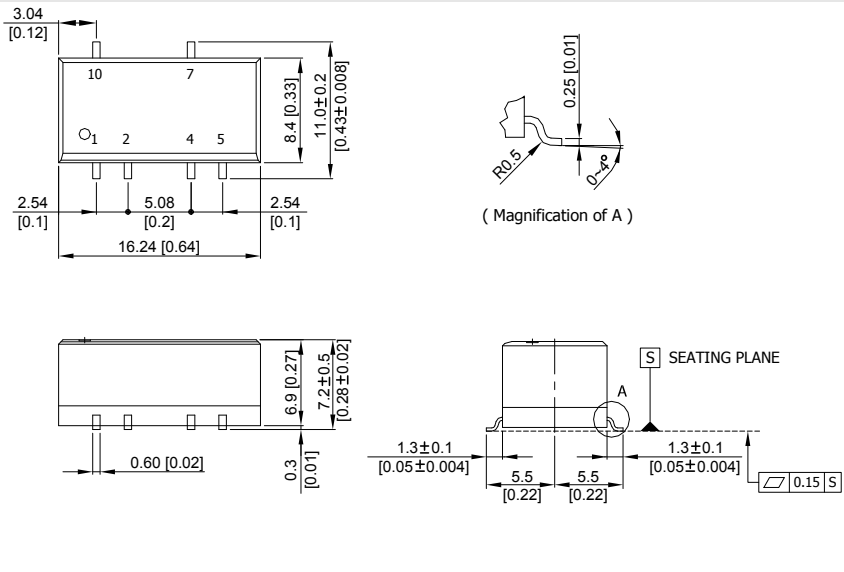
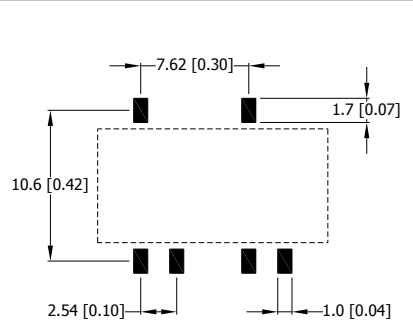
Package Specifications
Mechanical Dimensions (Single Output)

Connecting Pin Patterns

Mechanical Dimensions (Dual Output)

Connecting Pin Patterns

- ▶ All dimensions in mm (inches)
- ▶ Tolerance: X.X±0.25 (X.XX±0.01)
X.XX±0.13 (X.XXX±0.005)
- ▶ Pins ±0.05 (±0.002)

Pin Connections

Pin	Single Output	Dual Output
1	-Vin	-Vin
2	+Vin	+Vin
3	No Pin	No Pin
4	-Vout	Common
5	+Vout	-Vout
6	No Pin	No Pin
7	No Pin	+Vout
8	NA	No Pin
9	---	No Pin
10	---	NA

NA : Not Available for Electrical Connection

Physical Characteristics

Case Size (Single Output)	: 13.7x8.4x6.9mm (0.54x0.33x0.27 inches)
Case Size (Dual Output)	: 16.24x8.4x6.9mm (0.64x0.33x0.27 inches)
Case Material	: Non-Conductive Black Plastic (flammability to UL 94V-0 rated)
Pin Material	: phosphor bronze
Weight (Single Output)	: 1.7g
Weight (Dual Output)	: 2.0g

Test Setup

Input Reflected-Ripple Current Test Setup

Input reflected-ripple current is measured with an inductor L_{in} (4.7 μ H) and C_{in} (220 μ F, ESR < 1.0 Ω at 100 KHz) to simulate source impedance. Capacitor C_{in} , offsets possible battery impedance.

Current ripple is measured at the input terminals of the module, measurement bandwidth is 0-500 KHz.

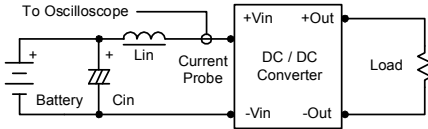

Peak-to-Peak Output Noise Measurement Test

Use a C_{out} 0.33 μ F ceramic capacitor. Scope measurement should be made by using a BNC socket, measurement bandwidth is 0-20 MHz. Position the load between 50 mm and 75 mm from the DC/DC Converter.

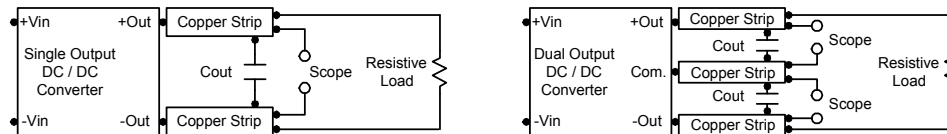

Technical Notes

Maximum Capacitive Load

The MSLU100 series has limitation of maximum connected capacitance at the output. The power module may be operated in current limiting mode during start-up, affecting the ramp-up and the startup time. For optimum performance we recommend 33 μ F maximum capacitive load. The maximum capacitance can be found in the data sheet.

Input Source Impedance

The power module should be connected to a low ac-impedance input source. Highly inductive source impedances can affect the stability of the power module.

In applications where power is supplied over long lines and output loading is high, it may be necessary to use a capacitor at the input to ensure startup.

Capacitor mounted close to the power module helps ensure stability of the unit, it is recommended to use a good quality low Equivalent Series Resistance (ESR < 1.0 Ω at 100 KHz) capacitor of a 2.2 μ F for the 5V input devices, a 1.0 μ F for the 12V input devices and a 0.47 μ F for the 24V input devices.

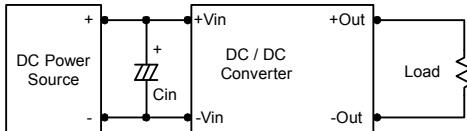

Output Ripple Reduction

A good quality low ESR capacitor placed as close as practicable across the load will give the best ripple and noise performance. To reduce output ripple, it is recommended to use 3.3 μ F capacitors at the output.

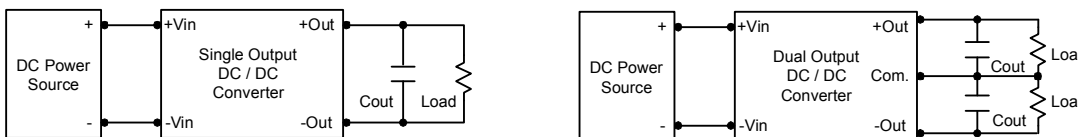

Thermal Considerations

Many conditions affect the thermal performance of the power module, such as orientation, airflow over the module and board spacing. To avoid exceeding the maximum temperature rating of the components inside the power module, the case temperature must be kept below 90°C. The derating curves are determined from measurements obtained in a test setup.

