

Description

Q-Tech QT625S low phase noise Space Qualified, 100kRad(Si) Tolerant Hybrid SAW Oscillators (SO) provide superior performance at operating frequencies from 400MHz to 1.3GHz. QT625S delivers low phase noise, -110dBc/Hz @1 kHz offset, -170 dBc/Hz noise floor. Typical vibration sensitivity is less than 2ppb/g.

The QT625S SO is a Class 2 hybrid per MIL-PRF-55310, hermetically sealed, and operated from -40°C to $+85^{\circ}\text{C}$. The design can employ internal frequency multiplication to optimize noise performance.

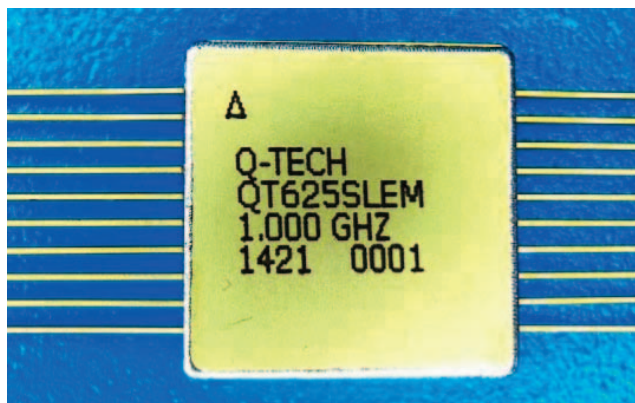

Features

- Made in USA
- Hermetically sealed packages
- Supply voltages 3.3Vdc and 5.0Vdc
- Wide temperature range -55°C to $+125^{\circ}\text{C}$
- Screened to MIL-PRF-55310, Level S or Modified MIL-PRF-38534, Class K
- Sine Wave Output
- 100k(Si) Radiation Tolerant
- Low Phase Noise
- Low Vibration sensitivity $<2\text{ppb/g}$

Applications

- Satellites
- Aerospace
- Low Jitter
- Low Noise High Frequency Reference

Ordering Information

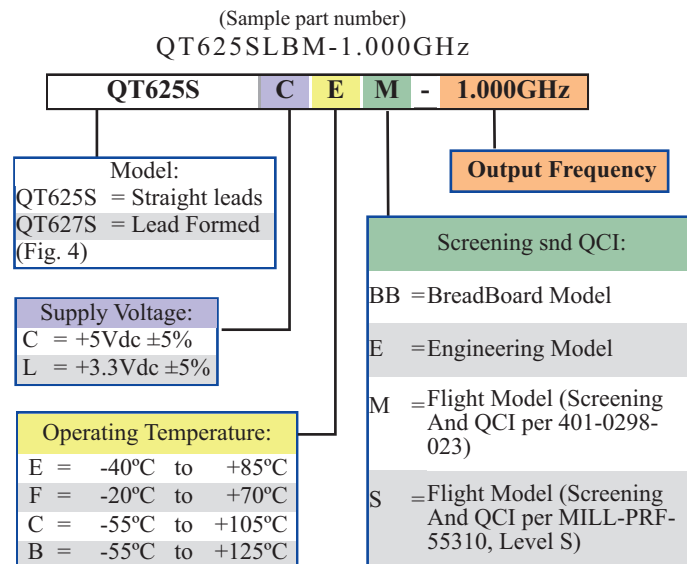

Packaging Options

- Standard ESD packaging

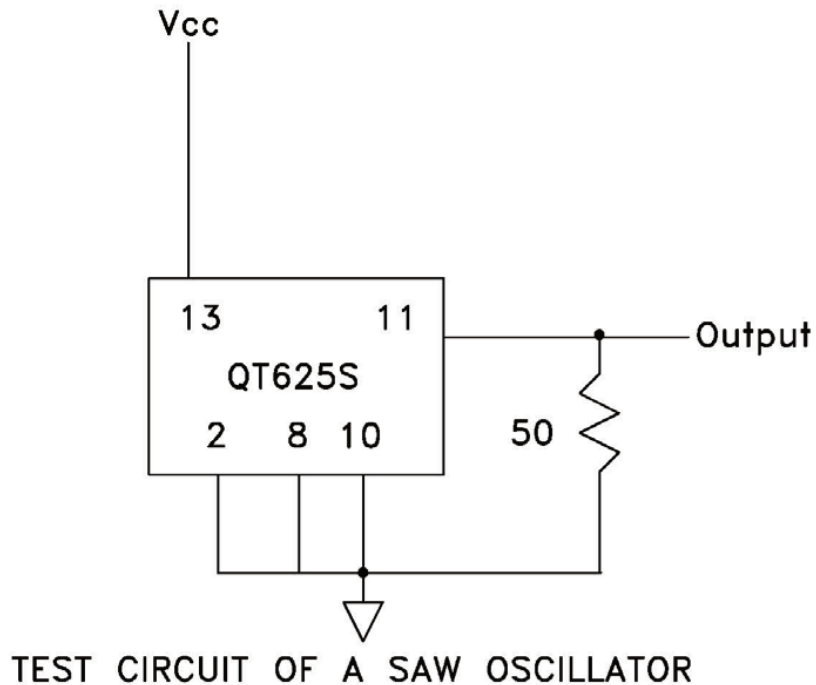

Figure 1

Absolute Maximum Ratings*1

Parameters	Symbol	Conditions	Rating	Unit
Supply voltage	Vcc	Between Vcc and Vss	- 0.5 to +7.0	V
Operating Temperature	Top		-55 to +125	°C
Junction Temperature	Tj		+150	°C
Storage Temperature	Tstg		- 65 to +150	°C
Lead solder Temperature/Time			+250/10	°C/s
Package Thermal Resistance	θ_{JC}		50	°C/W

*1. Vcc parameter ratings are values that must not be exceeded. This product may suffer permanent damage if maximum ratings are exceeded. Operation and characteristics are guaranteed within recommended operating conditions.

Package Outline - Dimensions are in inches

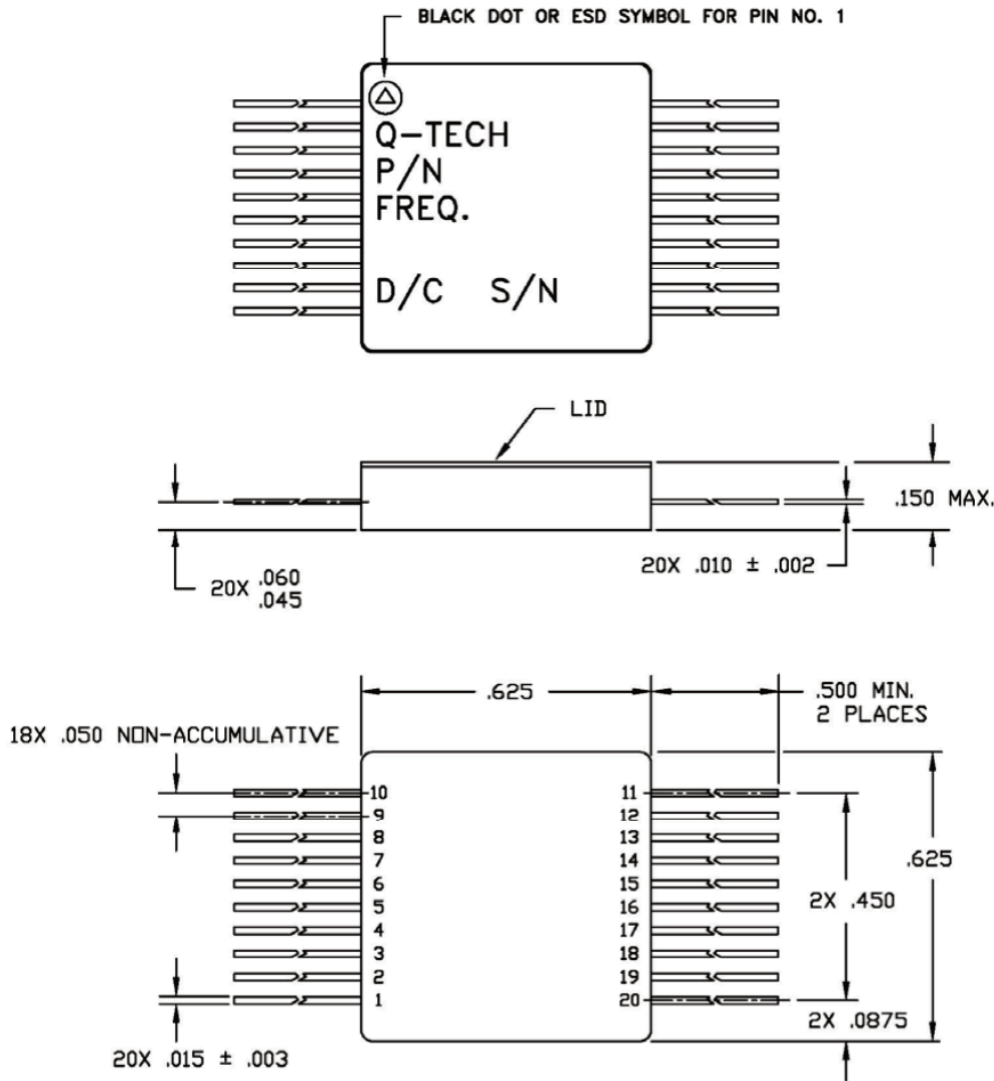

Figure 3

Pin no.	Function
2, 8, 10	Gnd / Case
11	Output
13	Vcc
Others	NC

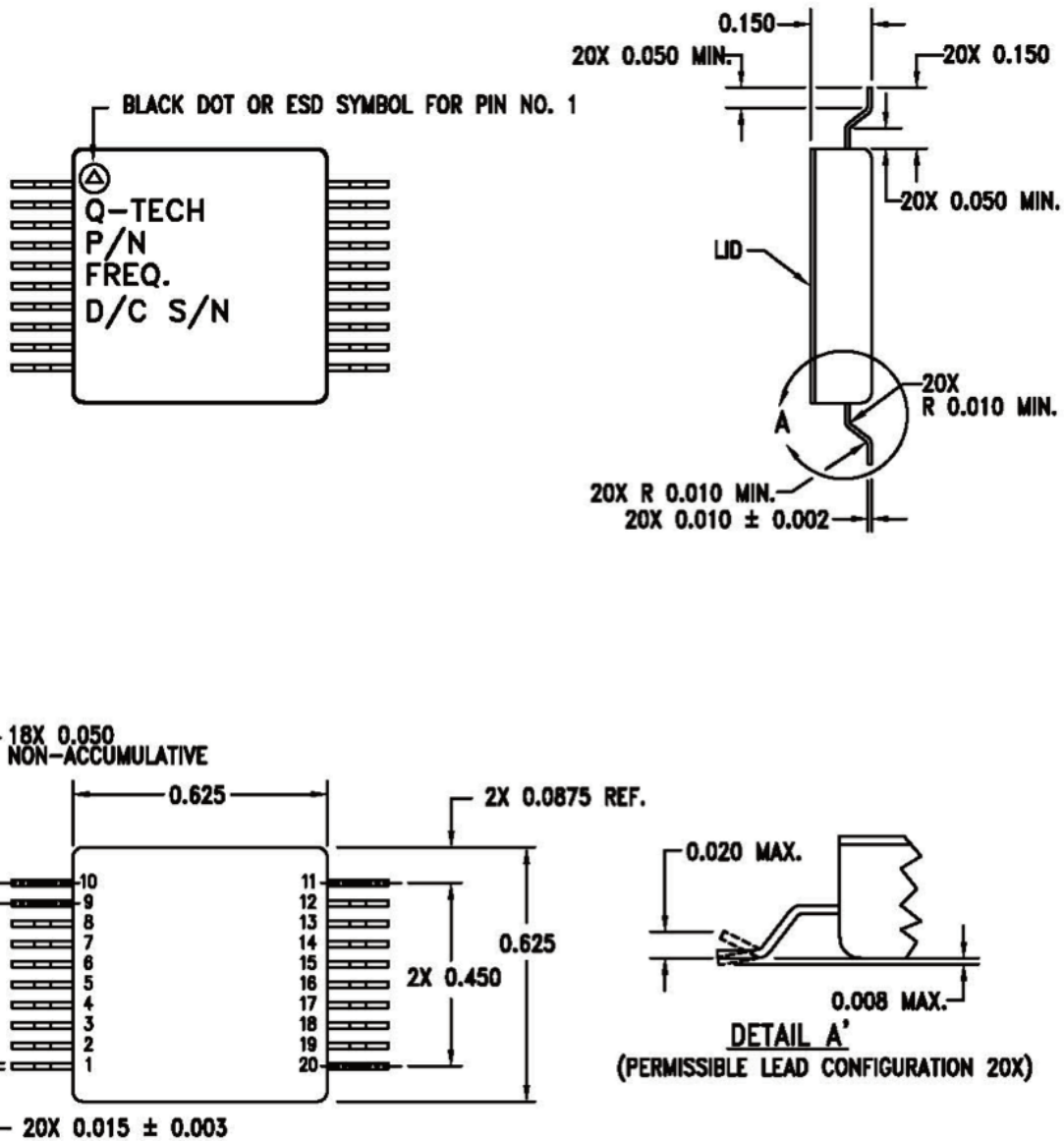

Figure 4

Pin no.	Function
2, 8, 10	Gnd / Case
11	Output
13	Vcc
Others	NC



100kRAD(Si) RADIATION TOLERANT SAW OSCILLATOR

QT625S Series - 3.3 and 5.0Vdc Space Qualified SO

Electrical Characteristics

Parameters	Symbol	Test Conditions *1	Min	Typ	Max	Unit
Center Frequency *2	FO		400		1.3	GHz
Supply Voltage	Vdd	3.3V±5%	3.135	3.3	3.465	V
		5.0V±5%	4.75	5.0	5.25	
Operating temperature	Top		-55	25	+125	°C
Frequency Stability *3	DF/DT	-40°C to +85°C	-400		+50	ppm
Input Current	Icc				60	mA
Output Power.	Po	50 ohms	7.0	8.0	12.0	dBm
Sub-Harmonics				-30	-20	dBc
Non-harmonics Spurious				<-80	<-80	dBc
SSB Phase Noise @ 500 MHz		At 1kHz		-121		dBc/Hz
		At 10kHz		-145		
		At 100kHz		-163		
		At 1MHz (Noise floor)		-170		
Vibration Sensitivity				1	2	ppb/g
Aging (at 70°C±3°C)		First(1) Year	-20	±10	20	ppm
		Life	-30		30	

*1 Test Conditions Unless Stated Otherwise: Nominal Vcc, Nominal Load, +25°C ± 3°C

*2 Direct Frequency Output or Internal Multiplication is used based on noise requirements.

*3 Stability includes Temperature, Vcc and Load Variations, and Aging.

Phase noise performance of a 1GHz SO at +25°C (X2 Multiplication used)

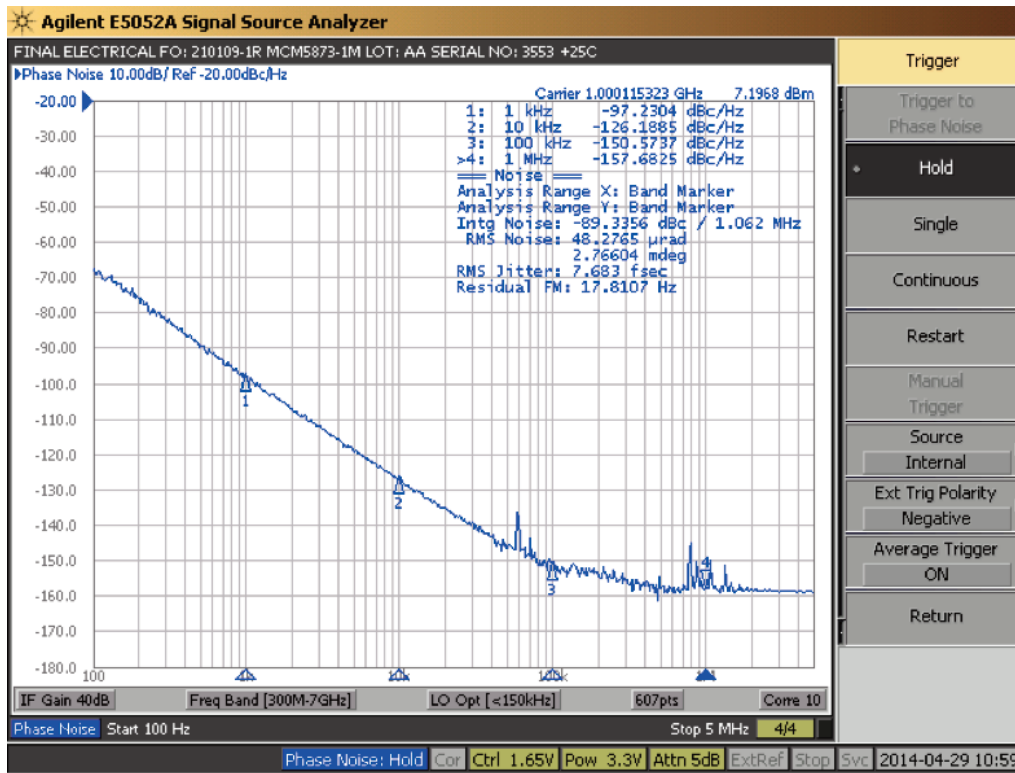

Phase noise performance of a 500 MHz SO at +25°C (Direct Frequency)

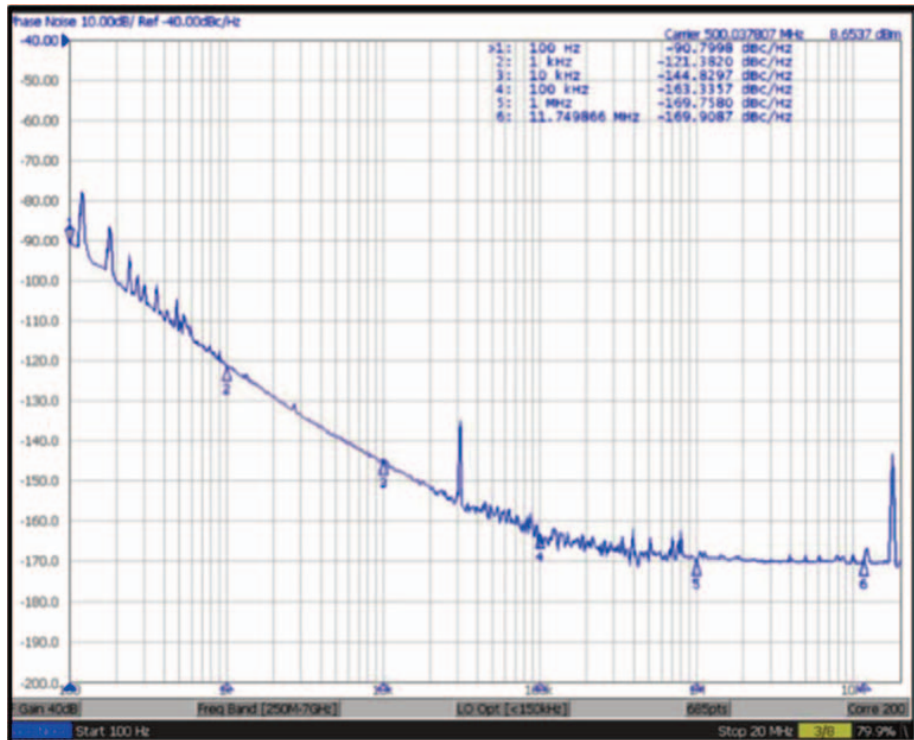

Output power spectrum including sub-harmonics of a 1GHz SO at +25°C

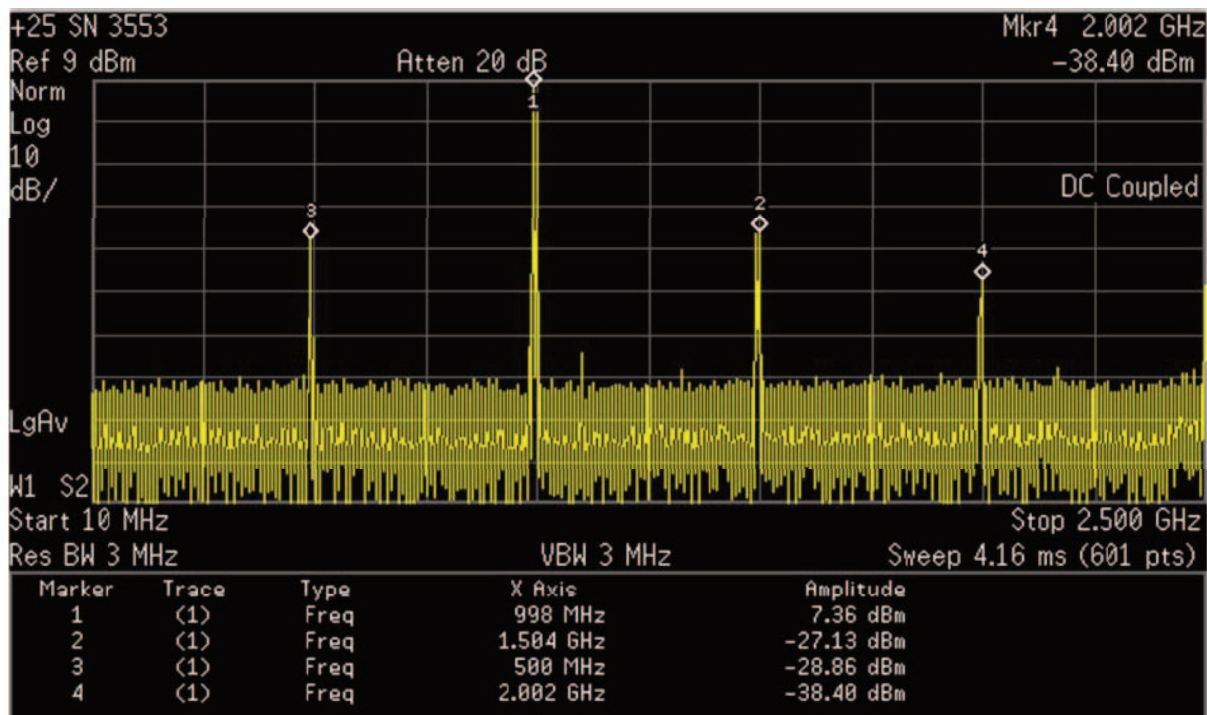

Output power spectrum including sub-harmonics of a 1GHz SO at +85°C

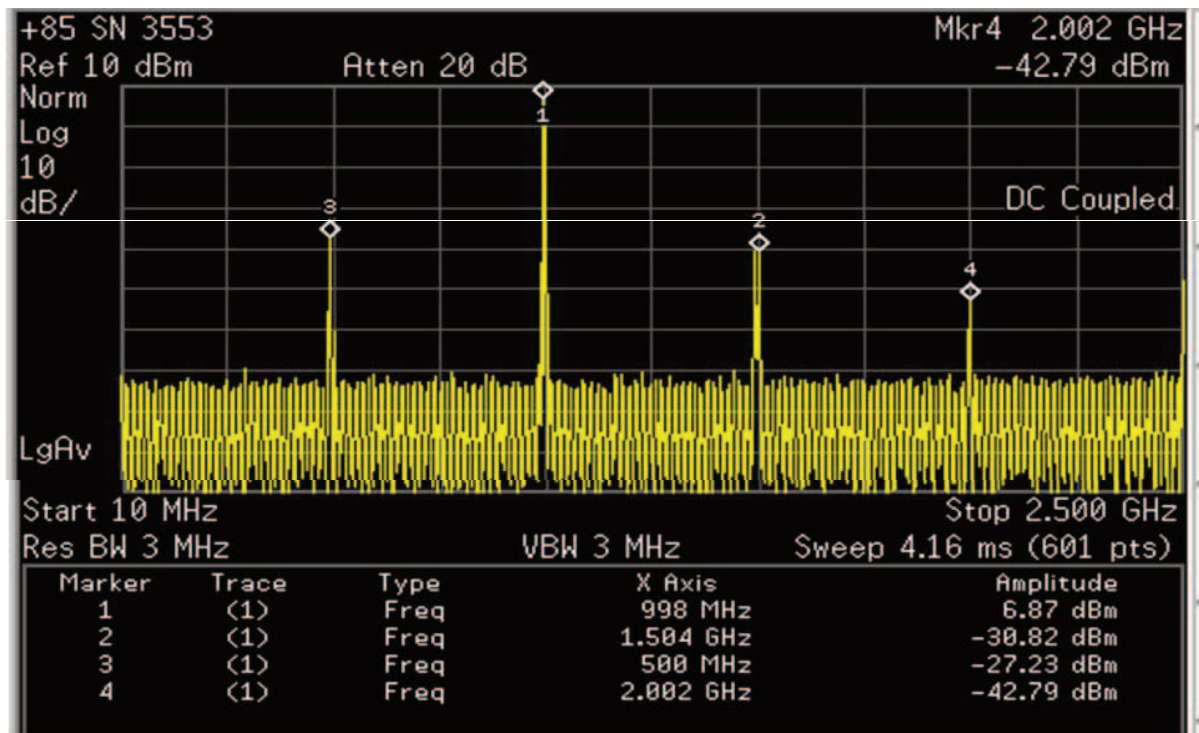

Frequency versus Temperature Curve

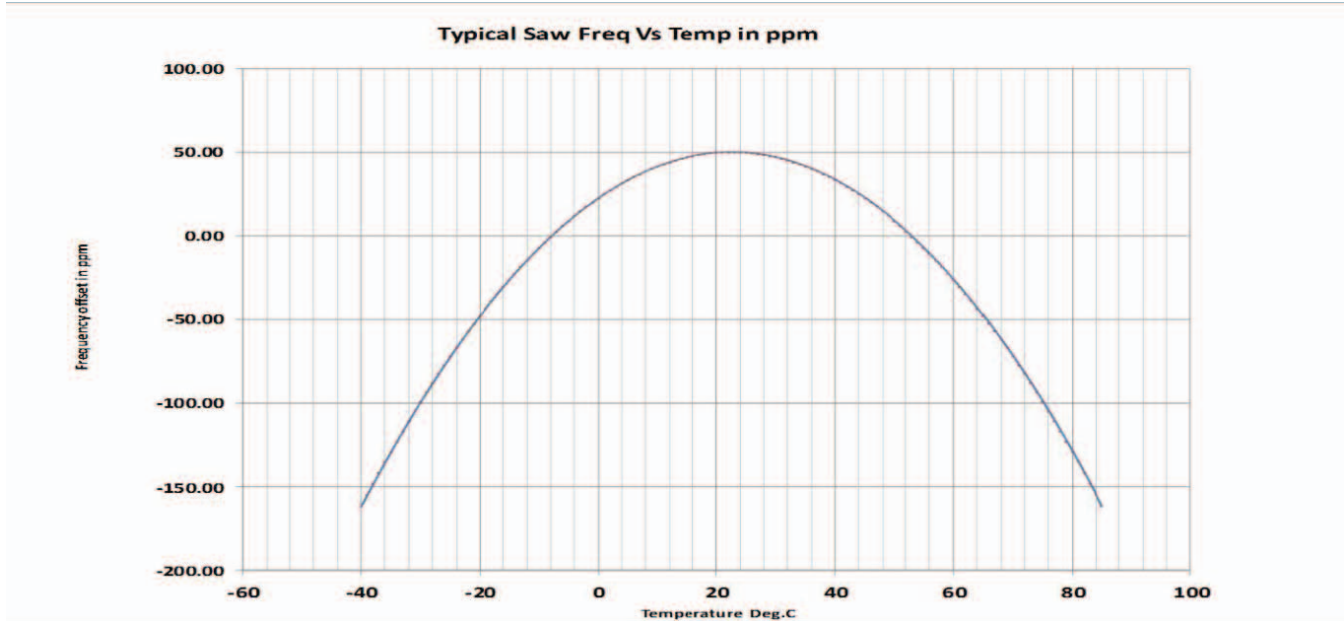

ESD Ratings

<p>Proper ESD precautions should be taken when handling and mounting semiconductor products. Built in ESD protection circuitry ratings are as follows:</p>		
Model	Minimum	Conditions
Human Body Model	Class 1C, 2000V	MIL-STD-883, Method 3015.7