

NAME	AMP P/N	ID MARK	WIRE RANGE	φd2	W	F	L	E	φD	φd1	t	QTY	BOX SIZE
1.25-3	1-440378-1	1.25-3	0.25~1.25mm ² 0.3(AWG#22) 0.5(AWG#20) 0.75(AWG#18) 1.25(AWG#16)	3.2 ^{+0.2} _{-0.2}	5.5 ±0.2	4.8 ±0.3	12.2 ^{+0.3} _{-1.0}	4.8 ±0.5	3.4 ^{+0.3} _{-0.2}	1.7 ±0.2	0.75 ±0.02	1,000	PM1
1.25-3.5M	1-440378-2	1.25-3.5M		3.7 ^{+0.2} _{-0.2}	6.6 ±0.2	6.3 ±0.3	14.2 ±1.0	4.8 ±0.5	3.4 ^{+0.3} _{-0.2}	1.7 ±0.2	0.75 ±0.02	1,000	PM1
1.25-4L	1-440378-3	1.25-4L		4.3 ^{+0.2} _{-0.2}	8.0 ±0.2	7.0 ±0.3	15.6 ^{+0.4} _{-1.0}	4.8 ±0.5	3.4 ^{+0.3} _{-0.2}	1.7 ±0.2	0.75 ±0.02	1,000	PM1
1.25-5	1-440378-4	1.25-5		5.3 ^{+0.2} _{-0.2}	8.0 ±0.2	7.0 ^{+0.3} _{-0.3}	15.6 ^{+0.4} _{-1.0}	4.8 ±0.5	3.4 ^{+0.3} _{-0.2}	1.7 ±0.2	0.75 ±0.02	1,000	PM1
2-3.5S	2-440378-1	2-3.5S		1.25~2.0mm ² 1.25(AWG#16) 2.0(AWG#14)	3.7 ^{+0.2} _{-0.2}	6.6 ±0.2	4.8 ±0.3	12.9 ±1.0	4.8 ±0.5	4.1 ^{+0.4} _{-0.1}	2.3 ±0.2	0.8 ^{+0.02} _{-0.02}	1,000
2-4L	2-440378-2	2-4L	4.3 ^{+0.2} _{-0.2}		8.5 ±0.2	7.4 ±0.3	16.5 ^{+0.5} _{-1.0}	4.8 ±0.5	4.1 ^{+0.4} _{-0.1}	2.3 ±0.2	0.8 ^{+0.02} _{-0.02}	1,000	PM1
2-5L	2-440378-3	2-5L	5.3 ^{+0.2} _{-0.2}		9.5 ±0.2	7.4 ±0.3	17.0 ^{+0.5} _{-1.0}	4.8 ±0.5	4.1 ^{+0.4} _{-0.1}	2.3 ±0.2	0.8 ^{+0.02} _{-0.02}	1,000	PM1
2-6	2-440378-4	2-6	6.4 ^{+0.4} _{-0.4}		12.0±0.2	10.9 ±0.3	21.7 ^{+0.3} _{-1.0}	4.8 ±0.5	4.1 ^{+0.4} _{-0.1}	2.3 ±0.2	0.8 ^{+0.02} _{-0.02}	1,000	PM2
2-8	2-440378-5	2-8	8.4 ^{+0.4} _{-0.4}		12.0±0.2	10.9 ±0.3	21.7 ^{+0.3} _{-1.0}	4.8 ±0.5	4.1 ^{+0.4} _{-0.1}	2.3 ±0.2	0.8 ^{+0.02} _{-0.02}	1,000	PM2
5.5-4L	5-440378-1	5.5-4L	3.5~5.5mm ² 3.5(AWG#12) 5.5(AWG#10)	4.3 ^{+0.2} _{-0.2}	9.5 ±0.2	8.3 ±0.3	19.1 ^{+0.9} _{-1.0}	6.0 ^{+0.5} _{-0.1}	5.6 ^{+0.3} _{-0.2}	3.4 ±0.2	1.0 ±0.02	1,000	PM2
5.5-5	5-440378-2	5.5-5		5.3 ^{+0.2} _{-0.2}	9.5 ±0.2	8.3 ±0.3	19.1 ^{+0.9} _{-1.0}	6.0 ^{+0.5} _{-0.1}	5.6 ^{+0.3} _{-0.2}	3.4 ±0.2	1.0 ±0.02	1,000	PM2
5.5-6	5-440378-3	5.5-6		6.4 ^{+0.4} _{-0.4}	12.0±0.2	10.3 ±0.3	22.3 ±1.0	6.0 ^{+0.5} _{-0.1}	5.6 ^{+0.3} _{-0.2}	3.4 ±0.2	1.0 ±0.02	1,000	PM2
5.5-8	5-440378-4	5.5-8		8.4 ^{+0.4} _{-0.4}	15.0±0.2	13.3 ±0.3	26.8 ±1.0	6.0 ^{+0.5} _{-0.1}	5.6 ^{+0.3} _{-0.2}	3.4 ±0.2	1.0 ±0.02	1,000	PM2
5.5-10	5-440378-5	5.5-10		10.5 ^{+0.4} _{-0.4}	15.0±0.2	13.5 ^{+0.3} _{-0.3}	26.8 ±1.0	6.0 ^{+0.5} _{-0.1}	5.6 ^{+0.3} _{-0.2}	3.4 ±0.2	1.0 ±0.02	1,000	PM2

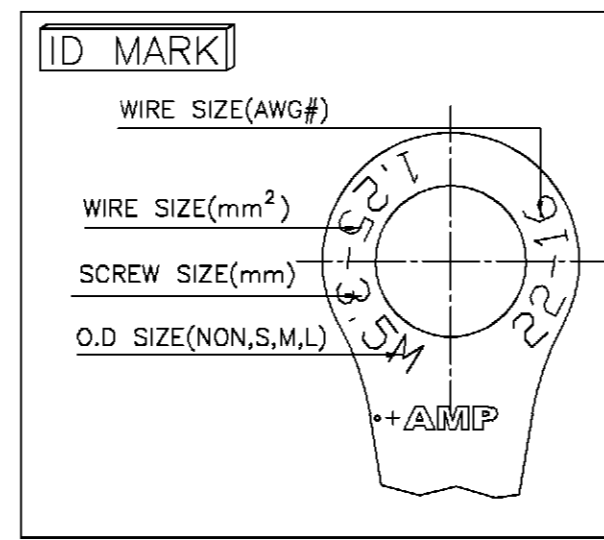
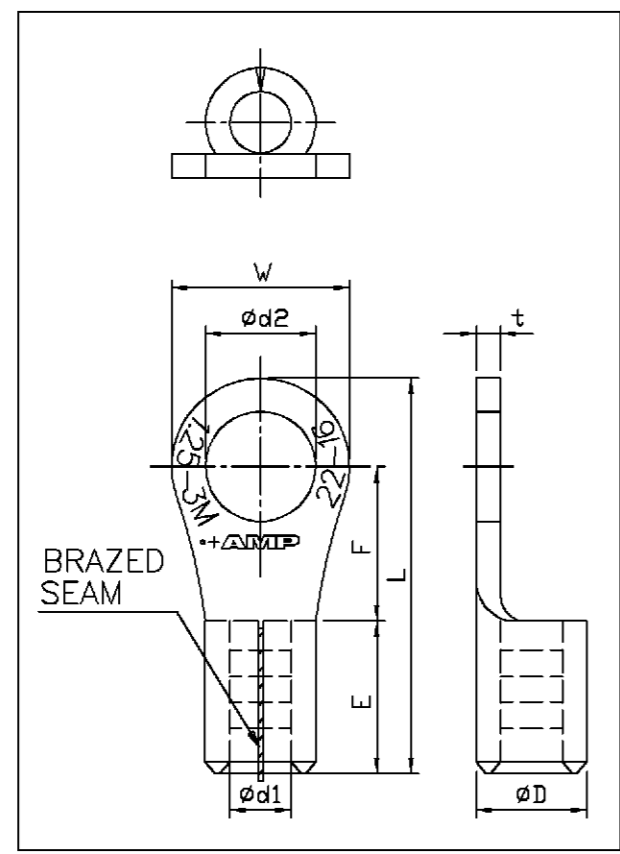

NOTE :

- 1.TERMINAL : NON INSULATED WITH BRAZED SEAM
- 2.BASIC TERMINALS MATERIAL : FINE GRADE HIGH CONDUCTIVITY COPPER PER JIS H3100
- 3.PLATING : TIN PLATED [2.5um MIN.]

DIMENSION :	0 PLC ±0.5	DR. O. HU 20-JUN-2001	AMP INCORPORATED. IPO
	1 PLC ±0.25		
MATERIAL	2 PLC ±0.12	CHK. J. CHENG 20-JUN-2001	NAME SOLISTLAND RING TERMINAL
	3 PLC ±0.08		
FINISH	ANGLES ±3°	APP. J. WU 20-JUN-2001	DRAWING NO C-440378
	SEE NOTE		
PRODUCT SPEC	108-57103	APPLICATION SPEC 114-57005	REV B
	SEE NOTE		
SCALE	--	WEIGHT	SHEET 1 OF 2

B	REVISED	FZ00-0011-01	OH JC	20JUN 2001
A	REVISED	FW00-0087-00	OH JC	13OCT 2000
O	FIRST RELEASED	FW00-0060-00	OH JC	16SEP 2000
LTR	REVISION RECORD	ECN	DR CHK	DATE

THIS INFORMATION IS CONFIDENTIAL AND IS DISCLOSED TO YOU ON CONDITION THAT NO FURTHER DISCLOSURE IS MADE BY YOU TO OTHER THAN AMP PERSONNEL WITHOUT WRITTEN AUTHORIZATION FROM AMP (TAIWAN) LTD. DIMENSION IN MILLIMETERS. DO NOT SCALE PRINT.

NUMBER C-440378
 METRIC
 3RD ANGLE PROJECTION
 THIS INFORMATION IS CONFIDENTIAL AND IS DISCLOSED TO YOU ON CONDITION THAT NO FURTHER DISCLOSURE IS MADE BY YOU TO OTHER THAN AMP PERSONNEL WITHOUT WRITTEN AUTHORIZATION FROM AMP (TAIWAN) LTD.
 DIMENSION IN MILLIMETERS. DO NOT SCALE PRINT.
 PRINT DIST DW
 LTR REVISION RECORD ECN DR/CHK DATE

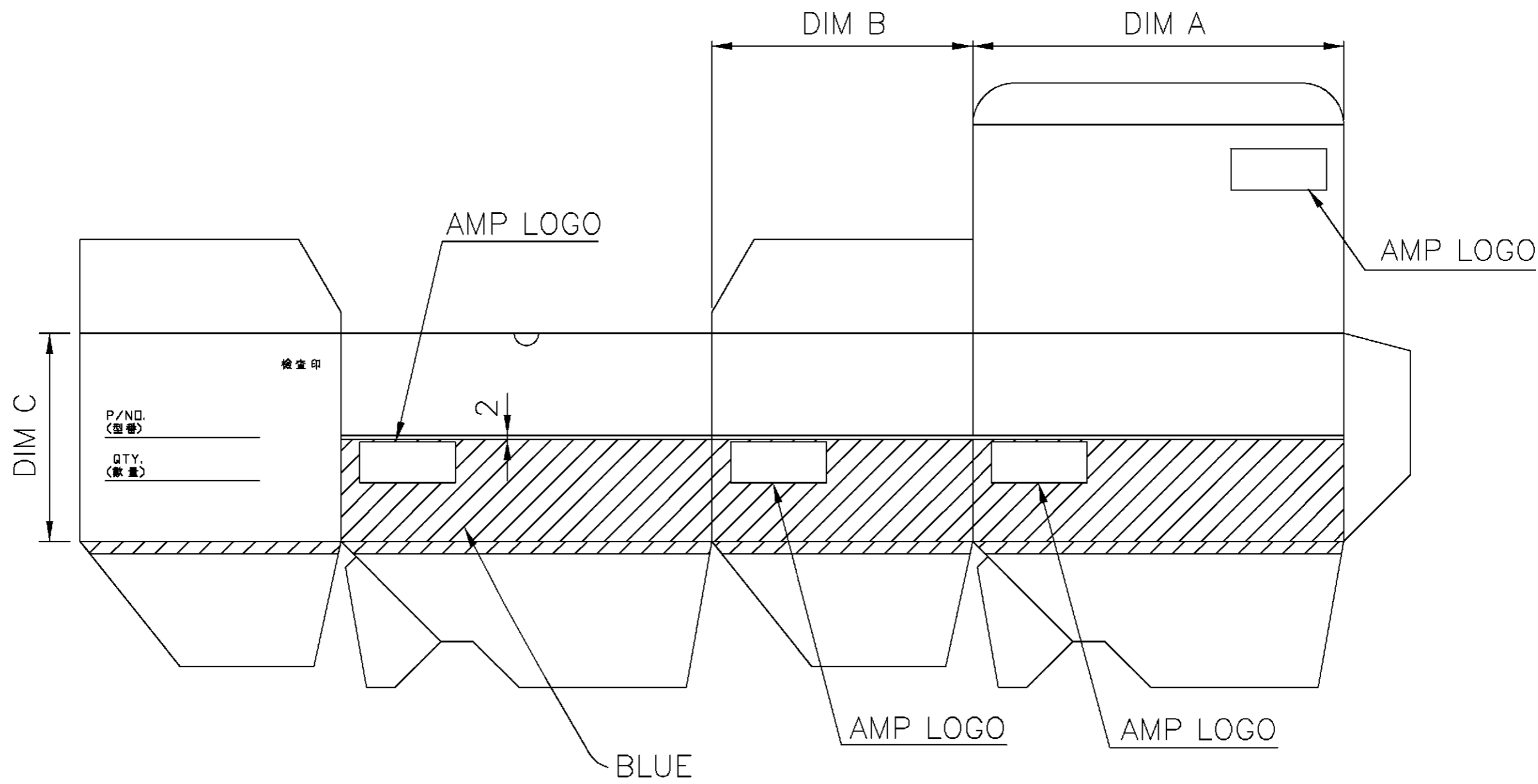

DIMENSION : 0 PLC ±0.5 1 PLC ±0.25 2 PLC ±0.12 3 PLC ±0.08 ANGLES ±3°	DR. O. HU 20-JUN-2001	AMP AMP INCORPORATED. IPO
	CHK. J. CHENG 20-JUN-2001	
MATERIAL SEE NOTE	APP. J. WU 20-JUN-2001	NAME SOLISTLAND RING TERMINAL
	PRODUCT SPEC	LOC SIZE DRAWING NO DW A ₃ C-440378
FINISH SEE NOTE	APPLICATION SPEC	REV B
	WEIGHT	SCALE -- SHEET 2 OF 2