

---

# HM514800C Series HM51S4800C Series

524,288-word × 8-bit Dynamic Random Access Memory

# HITACHI

---

## Description

The Hitachi HM51(S)4800C are CMOS dynamic RAM organized as 524,288-word × 8-bit. HM51(S)4800C have realized higher density, higher performance and various functions by employing 0.8 μm CMOS process technology and some new CMOS circuit design technologies. The HM51(S)4800C offer Fast Page Mode as a high speed access mode. Multiplexed address input permits the HM51(S)4800C to be packaged in standard 400-mil 28-pin plastic SOJ and standard 400-mil 28-pin plastic TSOPII. Internal refresh timer enables HM51S4800C self refresh operation.

## Features

- Single 5 V (± 10%)
- High speed
  - Access time: 60 ns/70 ns/80 ns (max)
- Low power dissipation
  - Active mode: 605 mW/550 mW/495 mW (max)
  - Standby mode:
    - 11 mW (max)
    - 1.1 mW (max) (L-version)
- Fast page mode capability
- 1,024 refresh cycles: 16 ms
  - 128 ms (L-version)
- 2 variations of refresh
  - $\overline{\text{RAS}}$ -only refresh
  - $\overline{\text{CAS}}$ -before- $\overline{\text{RAS}}$  refresh
- Battery backup operation (L-version)
- Self refresh operation (HM51S4800C)

---

## HM514800C, HM51S4800C Series

---

### Ordering Information

Type No.	Access Time	Package
HM514800CJ-6	60 ns	400-mil 28-pin plastic SOJ (CP-28D)
HM514800CJ-7	70 ns	
HM514800CJ-8	80 ns	
HM514800CLJ-6	60 ns	
HM514800CLJ-7	70 ns	
HM514800CLJ-8	80 ns	
HM51S4800CJ-6	60 ns	
HM51S4800CJ-7	70 ns	
HM51S4800CJ-8	80 ns	
HM51S4800CLJ-6	60 ns	
HM51S4800CLJ-7	70 ns	
HM51S4800CLJ-8	80 ns	
HM514800CTT-6	60 ns	400-mil 28-pin plastic TSOP II (TTP-28D)
HM514800CTT-7	70 ns	
HM514800CTT-8	80 ns	
HM514800CLTT-6	60 ns	
HM514800CLTT-7	70 ns	
HM514800CLTT-8	80 ns	
HM51S4800CTT-6	60 ns	
HM51S4800CTT-7	70 ns	
HM51S4800CTT-8	80 ns	
HM51S4800CLTT-6	60 ns	
HM51S4800CLTT-7	70 ns	
HM51S4800CLTT-8	80 ns	

---

## HM514800C, HM51S4800C Series

### Pin Arrangement

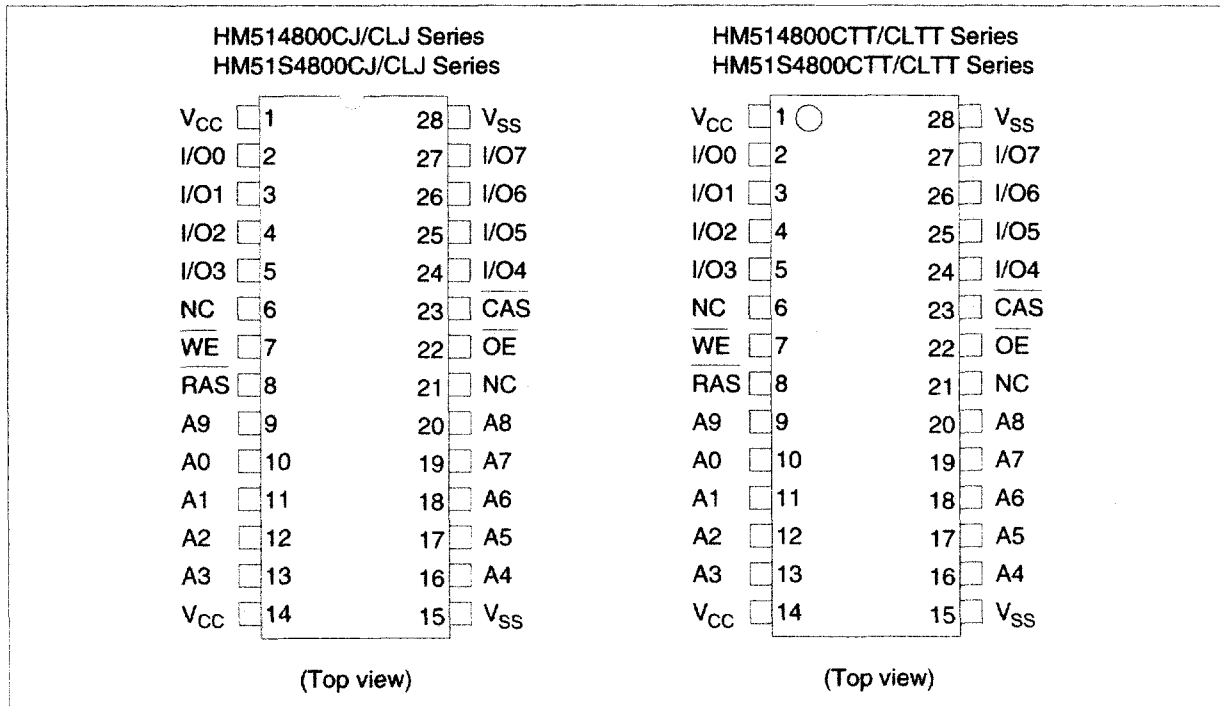

### Pin Description

Pin Name	Function
A0 – A9	Address input – Row address            A0 – A9 – Column address        A0 – A8 – Refresh address        A0 – A9
I/O0 – I/O7	Data-in/data-out
RAS	Row address strobe
CAS	Column address strobe
WE	Read/write enable
OE	Output enable
V <sub>CC</sub>	Power (+5 V)
V <sub>SS</sub>	Ground

# HM514800C, HM51S4800C Series

## Block Diagram

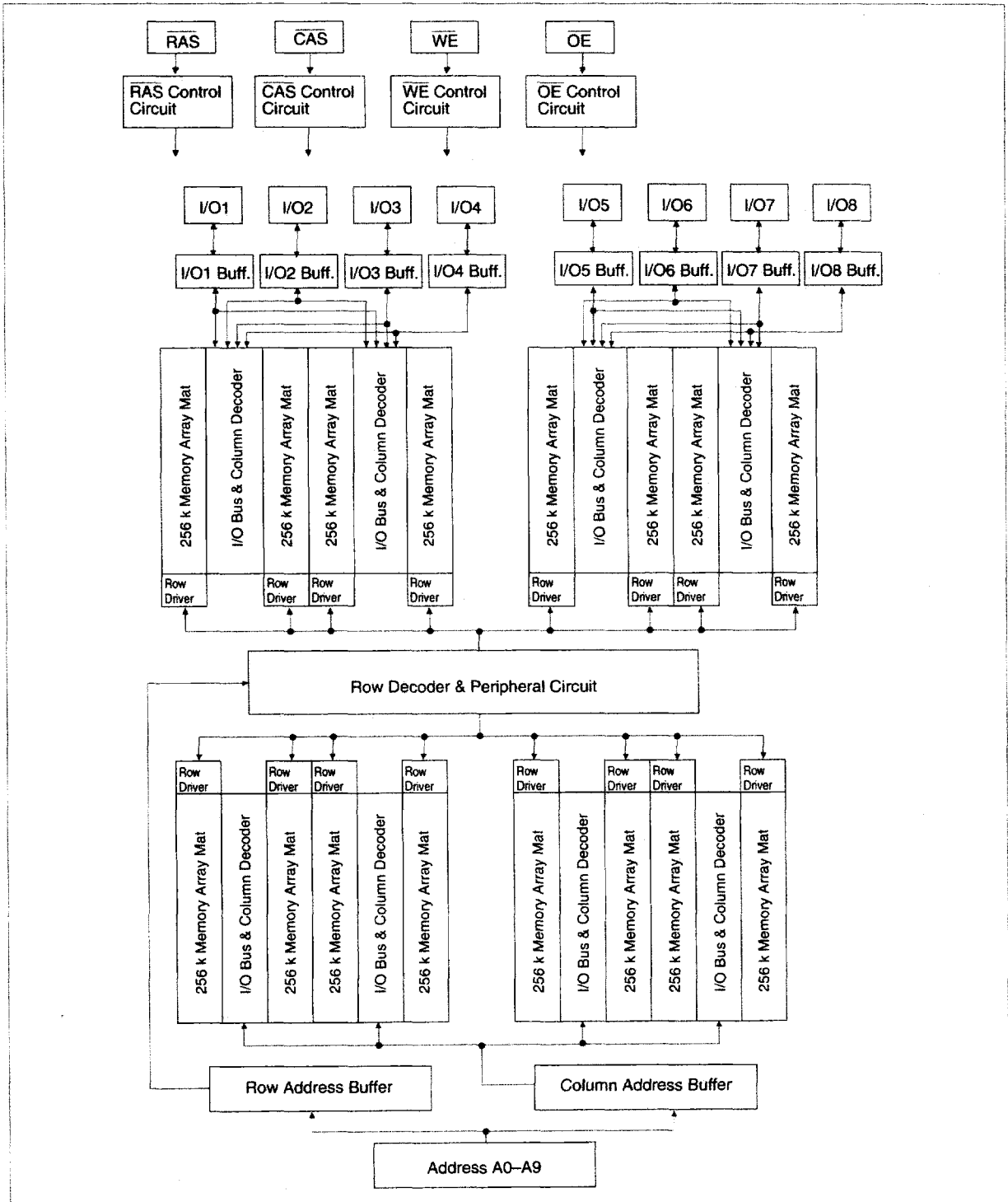

## HM514800C, HM51S4800C Series

### Operation Mode

The HM51(S)4800C series has the following 11 operation modes.

1. Read cycle
2. Early write cycle
3. Delayed write cycle
4. Read-modify-write cycle
5.  $\overline{\text{RAS}}$ -only refresh cycle
6.  $\overline{\text{CAS}}$ -before- $\overline{\text{RAS}}$  refresh cycle
7. Self refresh cycle (HM51S4800C)
8. Fast page mode read cycle
9. Fast page mode early write cycle
10. Fast page mode delayed write cycle
11. Fast page mode read-modify-write cycle

#### Inputs

$\overline{\text{RAS}}$	$\overline{\text{CAS}}$	$\overline{\text{WE}}$	$\overline{\text{OE}}$	Output	Operation
H	H	D	D	Open	Standby
H	L	H	L	Valid	Standby
L	L	H	L	Valid	Read cycle
L	L	L <sup>2</sup>	D	Open	Early write cycle
L	L	L <sup>2</sup>	H	Undefined	Delayed write cycle
L	L	H to L	L to H	Valid	Read-modify-write cycle
L	H	D	D	Open	$\overline{\text{RAS}}$ -only refresh cycle
H to L	L	D	D	Open	$\overline{\text{CAS}}$ -before- $\overline{\text{RAS}}$ refresh cycle Self refresh cycle (HM51S4800C)
L	H to L	H	L	Valid	Fast page mode read cycle
L	H to L	L <sup>2</sup>	D	Open	Fast page mode early write cycle
L	H to L	L <sup>2</sup>	H	Undefined	Fast page mode delayed write cycle
L	H to L	H to L	L to H	Valid	Fast page mode read-modify-write cycle
L	L	H	H	Open	Read cycle (Output disabled)

Notes: 1. H: High (inactive) L: Low (active) D: H or L

2.  $t_{\text{wcs}} \geq 0$  ns Early write cycle

$t_{\text{wcs}} < 0$  ns Delayed write cycle

## HM514800C, HM51S4800C Series

### Absolute Maximum Ratings

Parameter	Symbol	Value	Unit
Voltage on any pin relative to $V_{SS}$	$V_T$	-1.0 to +7.0	V
Supply voltage relative to $V_{SS}$	$V_{CC}$	-1.0 to +7.0	V
Short circuit output current	$I_{out}$	50	mA
Power dissipation	$P_T$	1.0	W
Operating temperature	$T_{opr}$	0 to +70	°C
Storage temperature	$T_{stg}$	-55 to +125	°C

### Recommended DC Operating Conditions ( $T_a = 0$ to +70°C) \*2

Parameter	Symbol	Min	Typ	Max	Unit	Notes
Supply voltage	$V_{SS}$	0	0	0	V	2
	$V_{CC}$	4.5	5.0	5.5	V	1, 2
Input high voltage	$V_{IH}$	2.4	—	6.5	V	1
Input low voltage	(I/O pin) $V_{IL}$	-1.0	—	0.8	V	1
	(Others) $V_{IL}$	-2.0	—	0.8	V	1

Notes: 1. All voltage referred to  $V_{SS}$ .

2. The supply voltage with all  $V_{CC}$  pins must be on the same level.

The supply voltage with all  $V_{SS}$  pins must be on the same level.

### DC Characteristics ( $T_a = 0$ to +70°C, $V_{CC} = 5\text{ V} \pm 10\%$ , $V_{SS} = 0\text{ V}$ ) \*5

Parameter	Symbol	HM514800C, HM51S4800C						Unit	Test Conditions
		-6		-7		-8			
		Min	Max	Min	Max	Min	Max		
Operating current <sup>1, 2</sup>	$I_{CC1}$	—	120	—	110	—	100	mA	$\overline{RAS}$ , $\overline{CAS}$ cycling $t_{RC} = \text{min}$
Standby current	$I_{CC2}$	—	2	—	2	—	2	mA	TTL interface $\overline{RAS}$ , $\overline{CAS} = V_{IH}$ Dout = High-Z
		—	1	—	1	—	1	mA	CMOS interface $\overline{RAS}$ , $\overline{CAS} \geq V_{CC} - 0.2\text{ V}$ Dout = High-Z
Standby current (L-version)	$I_{CC2}$	—	200	—	200	—	200	$\mu\text{A}$	CMOS interface $\overline{RAS}$ , $\overline{CAS} \geq V_{CC} - 0.2\text{ V}$ Dout = High-Z
$\overline{RAS}$ -only refresh current <sup>2</sup>	$I_{CC3}$	—	120	—	110	—	100	mA	$t_{RC} = \text{min}$

## HM514800C, HM51S4800C Series

**DC Characteristics** ( $T_a = 0$  to  $+70^\circ\text{C}$ ,  $V_{CC} = 5\text{ V} \pm 10\%$ ,  $V_{SS} = 0\text{ V}$ ) \*5 (cont)

Parameter	Symbol	HM514800C, HM51S4800C						Unit	Test Conditions
		-6		-7		-8			
		Min	Max	Min	Max	Min	Max		
Standby current <sup>1</sup>	$I_{CC5}$	—	5	—	5	—	5	mA	$\overline{\text{RAS}} = V_{\text{IH}}$ $\text{CAS} = V_{\text{IL}}$ Dout = enable
$\overline{\text{CAS}}$ -before- $\overline{\text{RAS}}$ refresh current <sup>4</sup>	$I_{CC6}$	—	120	—	110	—	100	mA	$t_{\text{RC}} = \text{min}$
Fast page mode current <sup>1,3</sup>	$I_{CC7}$	—	120	—	110	—	100	mA	$t_{\text{PC}} = \text{min}$
Battery backup current <sup>4</sup> (Standby with CBR refresh) (L-version)	$I_{CC10}$	—	300	—	300	—	300	$\mu\text{A}$	Standby: CMOS interface Dout = High-Z CBR refresh: $t_{\text{RC}} = 125\ \mu\text{s}$ $t_{\text{RAS}} \leq 1\ \mu\text{s}$ , $\text{CAS} = V_{\text{IL}}$ $\text{WE} = V_{\text{IH}}$
Self refresh mode current (HM51S4800C)	$I_{CC11}$	—	1	—	1	—	1	mA	CMOS interface $\overline{\text{RAS}}, \overline{\text{CAS}} \leq 0.2\text{ V}$ Dout = High-Z
Self refresh mode current (HM51S4800CL)	$I_{CC11}$	—	200	—	200	—	200	$\mu\text{A}$	CMOS interface $\overline{\text{RAS}}, \overline{\text{CAS}} \leq 0.2\text{ V}$ Dout = High-Z
Input leakage current	$I_{\text{LI}}$	-10	10	-10	10	-10	10	$\mu\text{A}$	$0\text{ V} \leq V_{\text{in}} \leq 6.5\text{ V}$
Output leakage current	$I_{\text{LO}}$	-10	10	-10	10	-10	10	$\mu\text{A}$	$0\text{ V} \leq V_{\text{out}} \leq 6.5\text{ V}$ Dout = disable
Output high voltage	$V_{\text{OH}}$	2.4	$V_{\text{CC}}$	2.4	$V_{\text{CC}}$	2.4	$V_{\text{CC}}$	V	High Iout = -5 mA
Output low voltage	$V_{\text{OL}}$	0	0.4	0	0.4	0	0.4	V	Low Iout = 4.2 mA

Notes: 1.  $I_{\text{CC}}$  depends on output load condition when the device is selected  $I_{\text{CC}}$  max is specified at the output open condition.

2. Address can be changed once or less while  $\overline{\text{RAS}} = V_{\text{IL}}$ .

3. Address can be changed once or less within one page cycle.

4.  $V_{\text{IH}} \geq V_{\text{CC}} - 0.2\text{ V}$ ,  $V_{\text{IL}} \leq 0.2\text{ V}$ ; Address can be changed once or less while  $\overline{\text{CAS}} = V_{\text{IL}}$

5. The supply voltage with all  $V_{\text{CC}}$  pins must be on the same level.

The supply voltage with all  $V_{\text{SS}}$  pins must be on the same level.

## HM514800C, HM51S4800C Series

Capacitance ( $T_a = 25^\circ\text{C}$ ,  $V_{CC} = 5\text{ V} \pm 10\%$ )

Parameter	Symbol	Typ	Max	Unit	Notes
Input capacitance (Address)	$C_{I1}$	—	5	pF	1
Input capacitance (Clocks)	$C_{I2}$	—	7	pF	1
Output capacitance (Data-in, Data-out)	$C_{VO}$	—	10	pF	1, 2

Notes: 1. Capacitance measured with Boonton Meter or effective capacitance measuring method.  
 2.  $\overline{\text{CAS}} = V_{IH}$  to disable Dout.

AC Characteristics ( $T_a = 0$  to  $70^\circ\text{C}$ ,  $V_{CC} = 5\text{ V} \pm 10\%$ ,  $V_{SS} = 0\text{ V}$ ) <sup>\*1, \*14, \*15</sup>

### Test conditions

- Input rise and fall time: 5 ns
- Input timing reference levels: 0.8 V, 2.4 V
- Input levels: 0 V, 3 V
- Output load: 2 TTL gate +  $C_L$  (100 pF) (Including scope and jig)

### Read, Write, Read-Modify-Write and Refresh Cycles (Common Parameters)

Parameter	Symbol	HM514800C, HM51S4800C						Unit	Notes
		-6		-7		-8			
		Min	Max	Min	Max	Min	Max		
Random read or write cycle time	$t_{RC}$	110	—	130	—	150	—	ns	
$\overline{\text{RAS}}$ precharge time	$t_{RP}$	40	—	50	—	60	—	ns	
$\overline{\text{RAS}}$ pulse width	$t_{RAS}$	60	10000	70	10000	80	10000	ns	
$\overline{\text{CAS}}$ pulse width	$t_{CAS}$	15	10000	20	10000	20	10000	ns	
Row address setup time	$t_{ASR}$	0	—	0	—	0	—	ns	
Row address hold time	$t_{RAH}$	10	—	10	—	10	—	ns	
Column address setup time	$t_{ASC}$	0	—	0	—	0	—	ns	
Column address hold time	$t_{CAH}$	15	—	15	—	15	—	ns	
$\overline{\text{RAS}}$ to $\overline{\text{CAS}}$ delay time	$t_{RCD}$	20	45	20	50	20	60	ns	8
$\overline{\text{RAS}}$ to column address delay time	$t_{RAD}$	15	30	15	35	15	40	ns	9
$\overline{\text{RAS}}$ hold time	$t_{RSH}$	20	—	20	—	20	—	ns	
$\overline{\text{CAS}}$ hold time	$t_{CSH}$	60	—	70	—	80	—	ns	
$\overline{\text{CAS}}$ to $\overline{\text{RAS}}$ precharge time	$t_{CRP}$	10	—	10	—	10	—	ns	

## HM514800C, HM51S4800C Series

### Read, Write, Read-Modify-Write and Refresh Cycles (Common Parameters) (cont)

Parameter	Symbol	HM514800C, HM51S4800C						Unit	Notes
		-6		-7		-8			
		Min	Max	Min	Max	Min	Max		
$\overline{OE}$ to Din delay time	$t_{ODD}$	15	—	20	—	20	—	ns	
$\overline{OE}$ delay time from Din	$t_{DZO}$	0	—	0	—	0	—	ns	
$\overline{CAS}$ setup time from Din	$t_{DZC}$	0	—	0	—	0	—	ns	
Transition time (rise and fall)	$t_T$	3	50	3	50	3	50	ns	7
Refresh period	$t_{REF}$	—	16	—	16	—	16	ms	
Refresh period (L-version)	$t_{REF}$	—	128	—	128	—	128	ms	

### Read Cycle

Parameter	Symbol	HM514800C, HM51S4800C						Unit	Notes
		-6		-7		-8			
		Min	Max	Min	Max	Min	Max		
Access time from $\overline{RAS}$	$t_{RAC}$	—	60	—	70	—	80	ns	2, 3
Access time from $\overline{CAS}$	$t_{CAC}$	—	15	—	20	—	20	ns	3, 4, 13
Access time from address	$t_{AA}$	—	30	—	35	—	40	ns	3, 5, 13
Access time from $\overline{OE}$	$t_{OAC}$	—	15	—	20	—	20	ns	
Read command setup time	$t_{RCS}$	0	—	0	—	0	—	ns	
Read command hold time to $\overline{CAS}$	$t_{RCH}$	0	—	0	—	0	—	ns	
Read command hold time to $\overline{RAS}$	$t_{RRH}$	0	—	0	—	0	—	ns	
Column address to $\overline{RAS}$ lead time	$t_{RAL}$	30	—	35	—	40	—	ns	
Output buffer turn-off time	$t_{OFF1}$	0	15	0	15	0	15	ns	6
Output buffer turn-off to $\overline{OE}$	$t_{OFF2}$	0	15	0	15	0	15	ns	6
$\overline{CAS}$ to Din delay time	$t_{CDD}$	15	—	15	—	15	—	ns	

## HM514800C, HM51S4800C Series

### Write Cycle

Parameter	Symbol	HM514800C, HM51S4800C						Unit	Notes
		-6		-7		-8			
		Min	Max	Min	Max	Min	Max		
Write command setup time	$t_{WCS}$	0	—	0	—	0	—	ns	10
Write command hold time	$t_{WCH}$	15	—	15	—	15	—	ns	
Write command pulse width	$t_{WP}$	10	—	10	—	10	—	ns	
Write command to $\overline{RAS}$ lead time	$t_{RWL}$	15	—	20	—	20	—	ns	
Write command to $\overline{CAS}$ lead time	$t_{CWL}$	15	—	20	—	20	—	ns	
Data-in setup time	$t_{DS}$	0	—	0	—	0	—	ns	11
Data-in hold time	$t_{DH}$	15	—	15	—	15	—	ns	11
$\overline{CAS}$ to $\overline{OE}$ delay time	$t_{COD}$	—	0	—	0	—	0	ns	18

### Read-Modify-Write Cycle

Parameter	Symbol	HM514800C, HM51S4800C						Unit	Notes
		-6		-7		-8			
		Min	Max	Min	Max	Min	Max		
Read-modify-write cycle time	$t_{RWC}$	150	—	180	—	200	—	ns	
$\overline{RAS}$ to $\overline{WE}$ delay time	$t_{RWD}$	80	—	95	—	105	—	ns	10
$\overline{CAS}$ to $\overline{WE}$ delay time	$t_{CWD}$	35	—	45	—	45	—	ns	10
Column address to $\overline{WE}$ delay time	$t_{AWD}$	50	—	60	—	65	—	ns	10, 13
$\overline{OE}$ hold time from $\overline{WE}$	$t_{OEH}$	15	—	20	—	20	—	ns	

### Refresh Cycle

Parameter	Symbol	HM514800C, HM51S4800C						Unit	Notes
		-6		-7		-8			
		Min	Max	Min	Max	Min	Max		
$\overline{CAS}$ setup time ( $\overline{CAS}$ -before- $\overline{RAS}$ refresh cycle)	$t_{CSR}$	10	—	10	—	10	—	ns	
$\overline{CAS}$ hold time ( $\overline{CAS}$ -before- $\overline{RAS}$ refresh cycle)	$t_{CHR}$	10	—	10	—	10	—	ns	
$\overline{RAS}$ precharge to $\overline{CAS}$ hold time	$t_{RPC}$	10	—	10	—	10	—	ns	
$\overline{CAS}$ precharge time in normal mode	$t_{CPN}$	10	—	10	—	10	—	ns	

## HM514800C, HM51S4800C Series

### Fast Page Mode Cycle

Parameter	Symbol	HM514800C, HM51S4800C						Unit	Notes
		-6		-7		-8			
		Min	Max	Min	Max	Min	Max		
Fast page mode cycle time	$t_{PC}$	40	—	45	—	50	—	ns	
Fast page mode $\overline{CAS}$ precharge time	$t_{CP}$	10	—	10	—	10	—	ns	
Fast page mode $\overline{RAS}$ pulse width	$t_{RASC}$	—	100000	—	100000	—	100000	ns	12
Access time from $\overline{CAS}$ precharge	$t_{ACP}$	—	35	—	40	—	45	ns	3, 13
$\overline{RAS}$ hold time from $\overline{CAS}$ precharge	$t_{RHCP}$	35	—	40	—	45	—	ns	
Fast page mode read-modify-write cycle $\overline{CAS}$ precharge to $\overline{WE}$ delay time	$t_{CPW}$	55	—	65	—	70	—	ns	
Fast page mode read-modify-write cycle time	$t_{PCM}$	80	—	95	—	100	—	ns	

### Self-refresh Mode

Parameter	Symbol	HM514800C, HM51S4800C						Unit	Notes
		-6		-7		-8			
		Min	Max	Min	Max	Min	Max		
$\overline{RAS}$ pulse width (self-refresh)	$t_{RASS}$	100	—	100	—	100	—	$\mu s$	19, 20, 21, 22
$\overline{RAS}$ precharge time (self-refresh)	$t_{RPS}$	110	—	130	—	150	—	ns	
$\overline{CAS}$ hold time (self-refresh)	$t_{CHS}$	-50	—	-50	—	-50	—	ns	

---

## HM514800C, HM51S4800C Series

---

- Notes:
1. AC measurements assume  $t_T = 5$  ns.
  2. Assumes that  $t_{RCD} \leq t_{RCD}(\text{max})$  and  $t_{RAD} \leq t_{RAD}(\text{max})$ . If  $t_{RCD}$  or  $t_{RAD}$  is greater than the maximum recommended value shown in this table,  $t_{RAC}$  exceeds the value shown.
  3. Measured with a load circuit equivalent to 2 TTL loads and 100 pF.
  4. Assumes that  $t_{RCD} \geq t_{RCD}(\text{max})$  and  $t_{RAD} \leq t_{RAD}(\text{max})$ .
  5. Assumes that  $t_{RCD} \leq t_{RCD}(\text{max})$  and  $t_{RAD} \geq t_{RAD}(\text{max})$ .
  6.  $t_{OFF}(\text{max})$  defines the time at which the output achieves the open circuit condition and is not referred to output voltage levels.
  7.  $V_{IH}(\text{min})$  and  $V_{IL}(\text{max})$  are reference levels for measuring timing of input signals. Also, transition times are measured between  $V_{IH}$  and  $V_{IL}$ .
  8. Operation with the  $t_{RCD}(\text{max})$  limit insures that  $t_{RAC}(\text{max})$  can be met,  $t_{RCD}(\text{max})$  is specified as a reference point only, if  $t_{RCD}$  is greater than the specified  $t_{RCD}(\text{max})$  limit, then access time is controlled exclusively by  $t_{CAC}$ .
  9. Operation with the  $t_{RAD}(\text{max})$  limit insures that  $t_{RAC}(\text{max})$  can be met,  $t_{RAD}(\text{max})$  is specified as a reference point only, if  $t_{RAD}$  is greater than the specified  $t_{RAD}(\text{max})$  limit, then access time is controlled exclusively by  $t_{AA}$ .
  10.  $t_{WCS}$ ,  $t_{RWD}$ ,  $t_{CWD}$  and  $t_{AWD}$  are not restrictive operating parameters. They are included in the data sheet as electrical characteristics only: if  $t_{WCS} \geq t_{WCS}(\text{min})$ , the cycle is an early write cycle and the data out pin will remain open circuit (high impedance) throughout the entire cycle; if  $t_{RWD} \geq t_{RWD}(\text{min})$ ,  $t_{CWD} \geq t_{CWD}(\text{min})$ ,  $t_{AWD} \geq t_{AWD}(\text{min})$  and  $t_{CPW} \geq t_{CPW}(\text{min})$ , the cycle is a read-modify-write and the data output will contain data read from the selected cell; if neither of the above sets of conditions is satisfied, the condition of the data out (at access time) is indeterminate.
  11. These parameters are referred to  $\overline{\text{CAS}}$  leading edge in an early write cycle and to  $\overline{\text{WE}}$  leading edge in a delayed write or a read-modify-write cycle.
  12.  $t_{RASC}$  defines  $\overline{\text{RAS}}$  pulse width in fast page mode cycles.
  13. Access time is determined by the longest among  $t_{AA}$ ,  $t_{CAC}$  and  $t_{ACP}$ .
  14. An initial pause of 100  $\mu\text{s}$  is required after power up followed by a minimum of eight initialization cycles ( $\overline{\text{RAS}}$ -only refresh cycle or  $\overline{\text{CAS}}$ -before- $\overline{\text{RAS}}$  refresh cycle). If the internal refresh counter is used, a minimum of eight  $\overline{\text{CAS}}$ -before- $\overline{\text{RAS}}$  refresh cycles is required.
  15. In delayed write or read-modify-write cycles,  $\overline{\text{OE}}$  must disable output buffer prior to applying data to the device.
  16. Either  $t_{RCH}$  or  $t_{RRH}$  must be satisfied for a read cycle.
  17. The supply voltage with all  $V_{CC}$  pins must be on the same level.  
The supply voltage with all  $V_{SS}$  pins must be on the same level.
  18. Do not enable Dout buffer when using delayed write timing.
  19. Please do not use  $t_{RASS}$  timing,  $10 \mu\text{s} \leq t_{RASS} \leq 100 \mu\text{s}$ . During this period, the device is in transition state from normal operation mode to self refresh mode. If  $t_{RASS} \geq 100 \mu\text{s}$ , then  $\overline{\text{RAS}}$  precharge time should use  $t_{RPS}$  instead of  $t_{RP}$ .
  20. If you use distributed CBR refresh mode with 15.6  $\mu\text{s}$  interval in normal read/write cycle, CBRrefresh should be executed within 15.6  $\mu\text{s}$  immediately after exiting from and before entering into self refresh mode.
  21. If you use  $\overline{\text{RAS}}$  only refresh or CBR burst refresh mode in normal read/write cycle, 1024 cycles of distributed CBR refresh with 15.6  $\mu\text{s}$  interval should be executed within 16 ms immediately after exiting from and before entering into the self refresh mode.
  22. Repetitive self refresh mode without refreshing all memory is not allowed. Once you exit from self refresh mode, all memory cells need to be refreshed before re-entering the self refresh mode again.
  23. XXX: H or L (H:  $V_{IH}(\text{min}) \leq V_{IN} \leq V_{IH}(\text{max})$ , L:  $V_{IL}(\text{min}) \leq V_{IN} \leq V_{IL}(\text{max})$ )  
/////: Invalid Dout

---

## **HM514800C, HM51S4800C Series**

---

When the address, clock and input pins are not described on timing waveforms, their pins must be applied  $V_{IH}$  or  $V_{IL}$ .

# HM514800C, HM51S4800C Series

## Timing Waveforms\*23

### Read Cycle

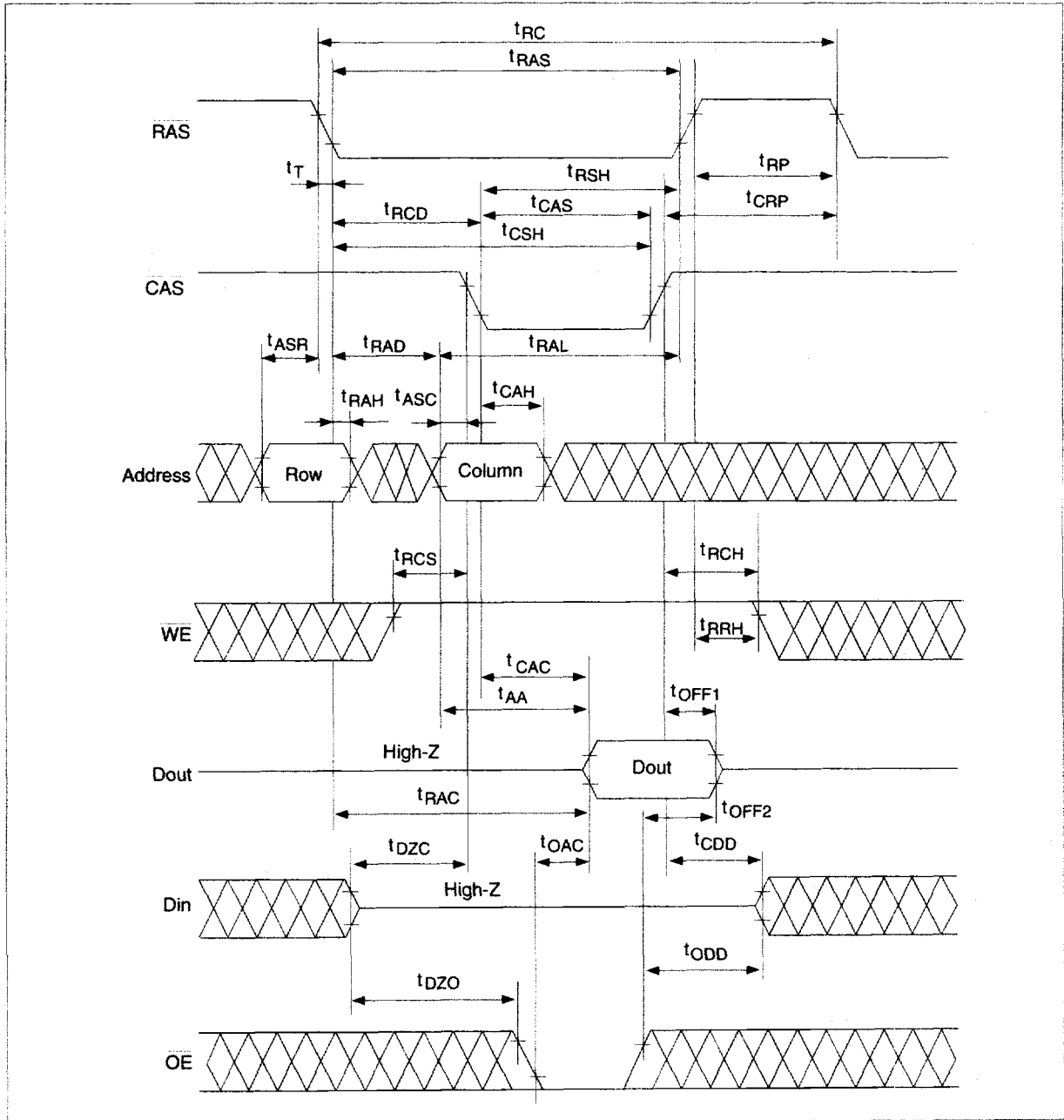

Early Write Cycle

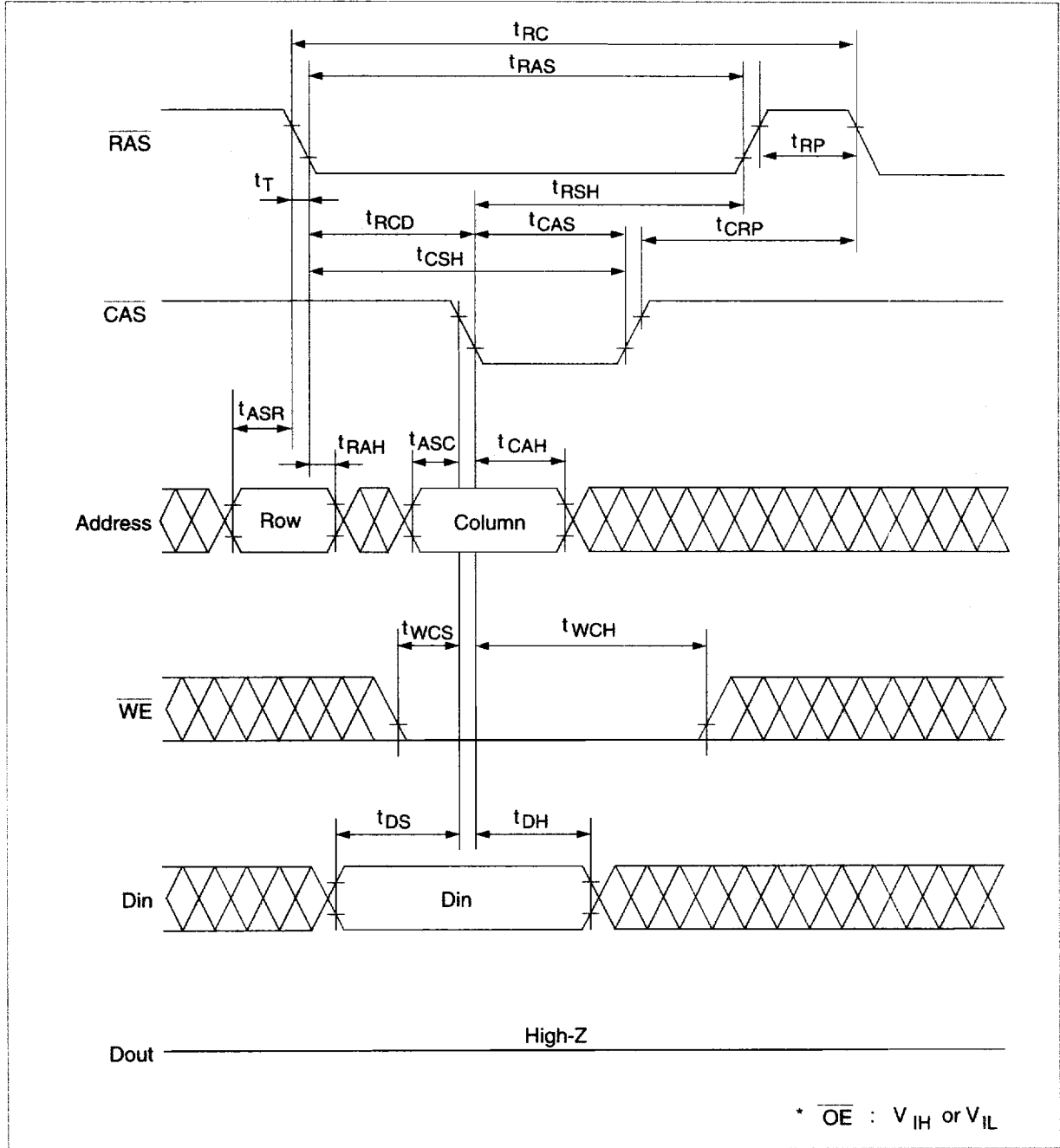

# HM514800C, HM51S4800C Series

## Delayed Write Cycle

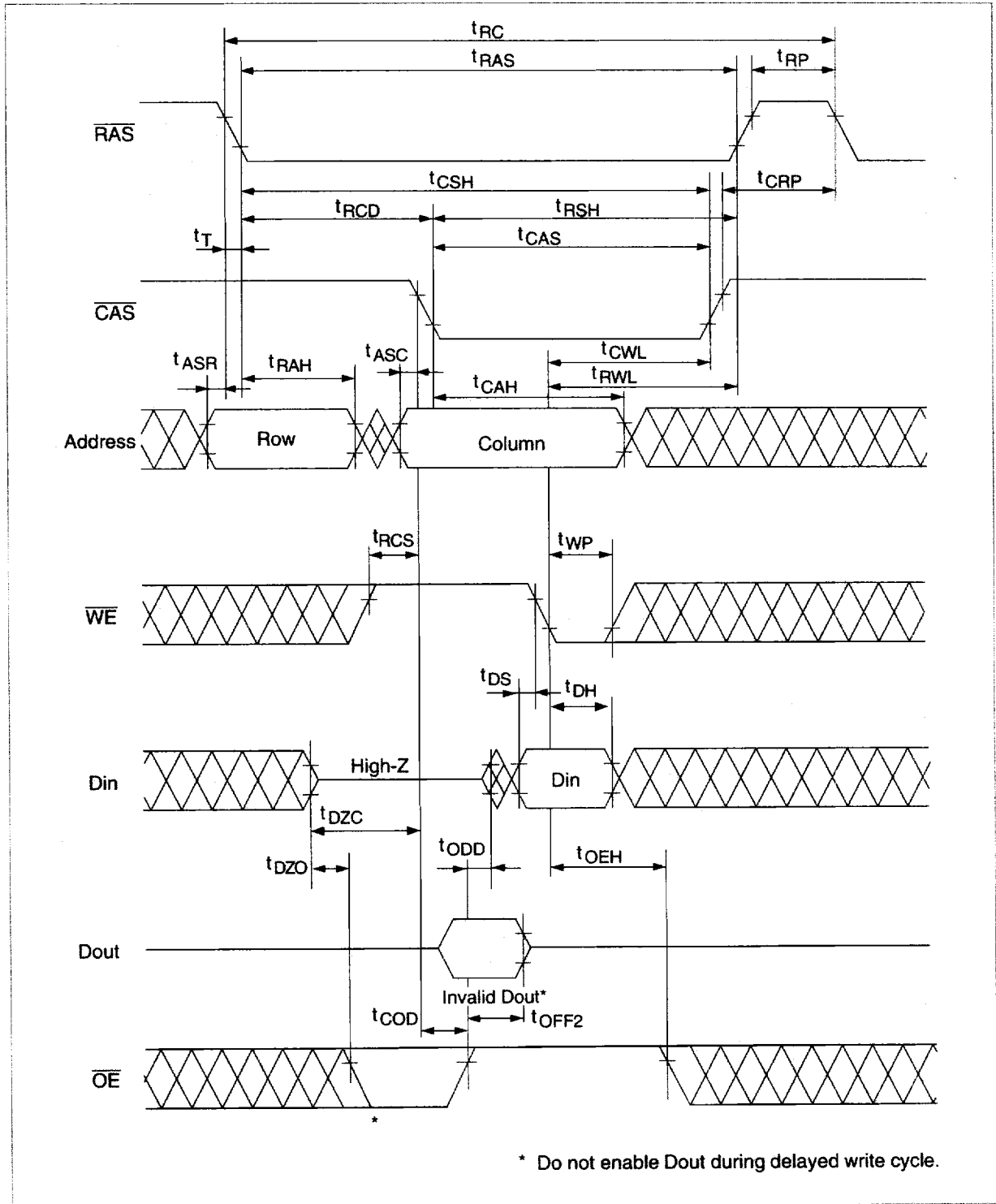

# HM514800C, HM51S4800C Series

## Read-Modify-Write Cycle

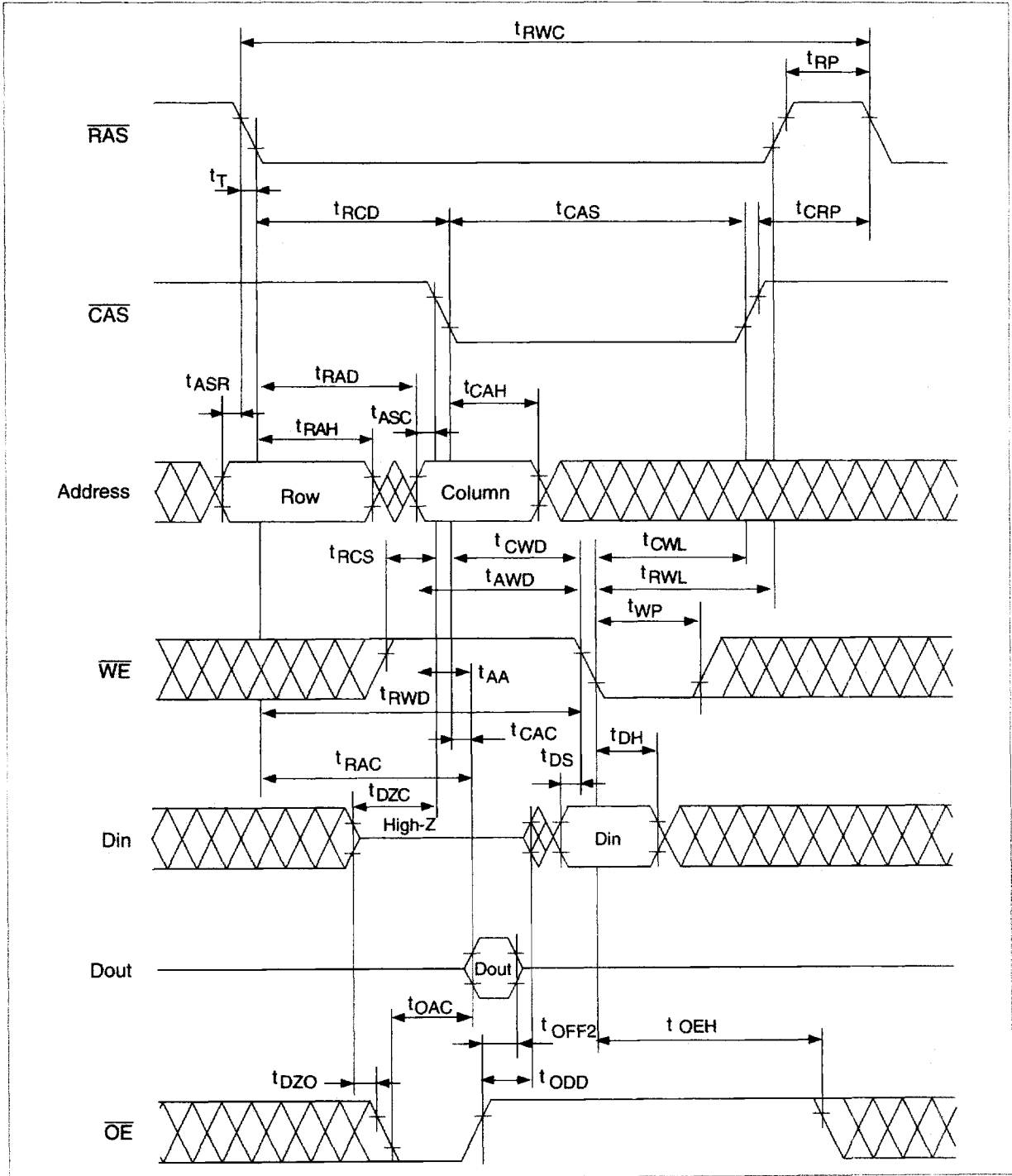

# HM514800C, HM51S4800C Series

## RAS-Only Refresh Cycle

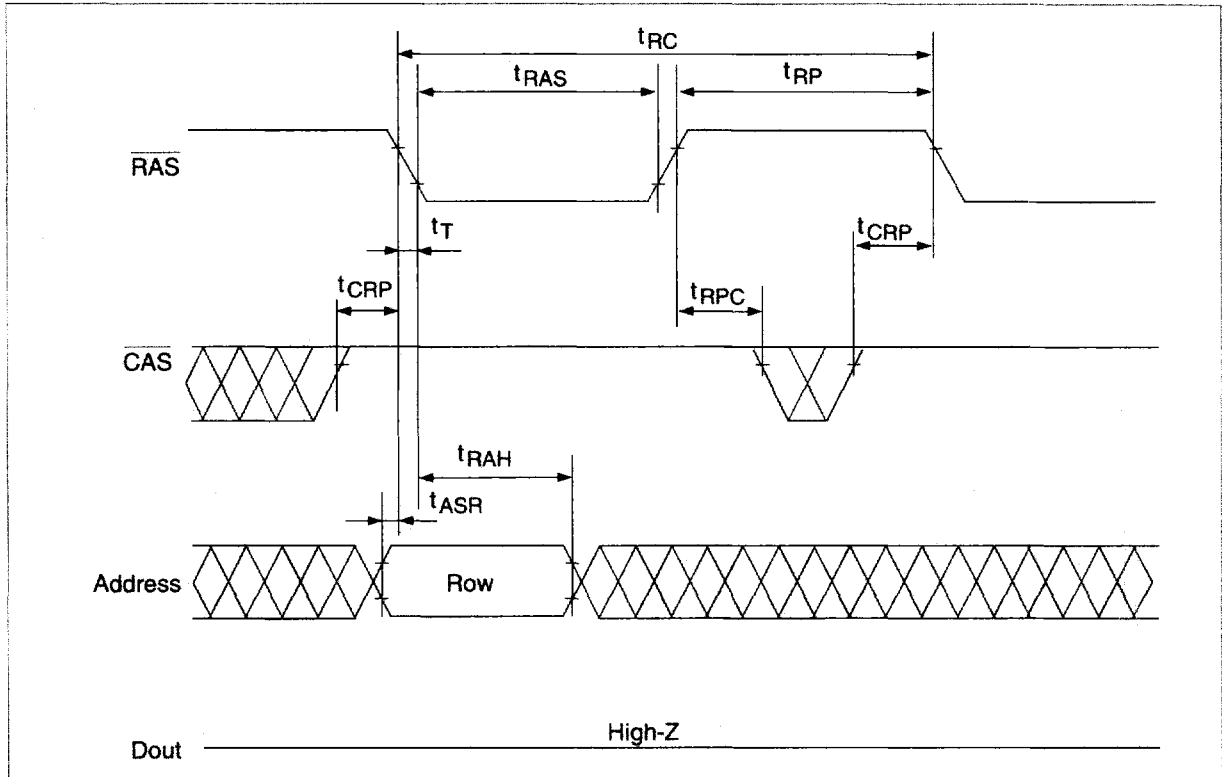





# HM514800C, HM51S4800C Series

## Fast Page Mode Early Write Cycle

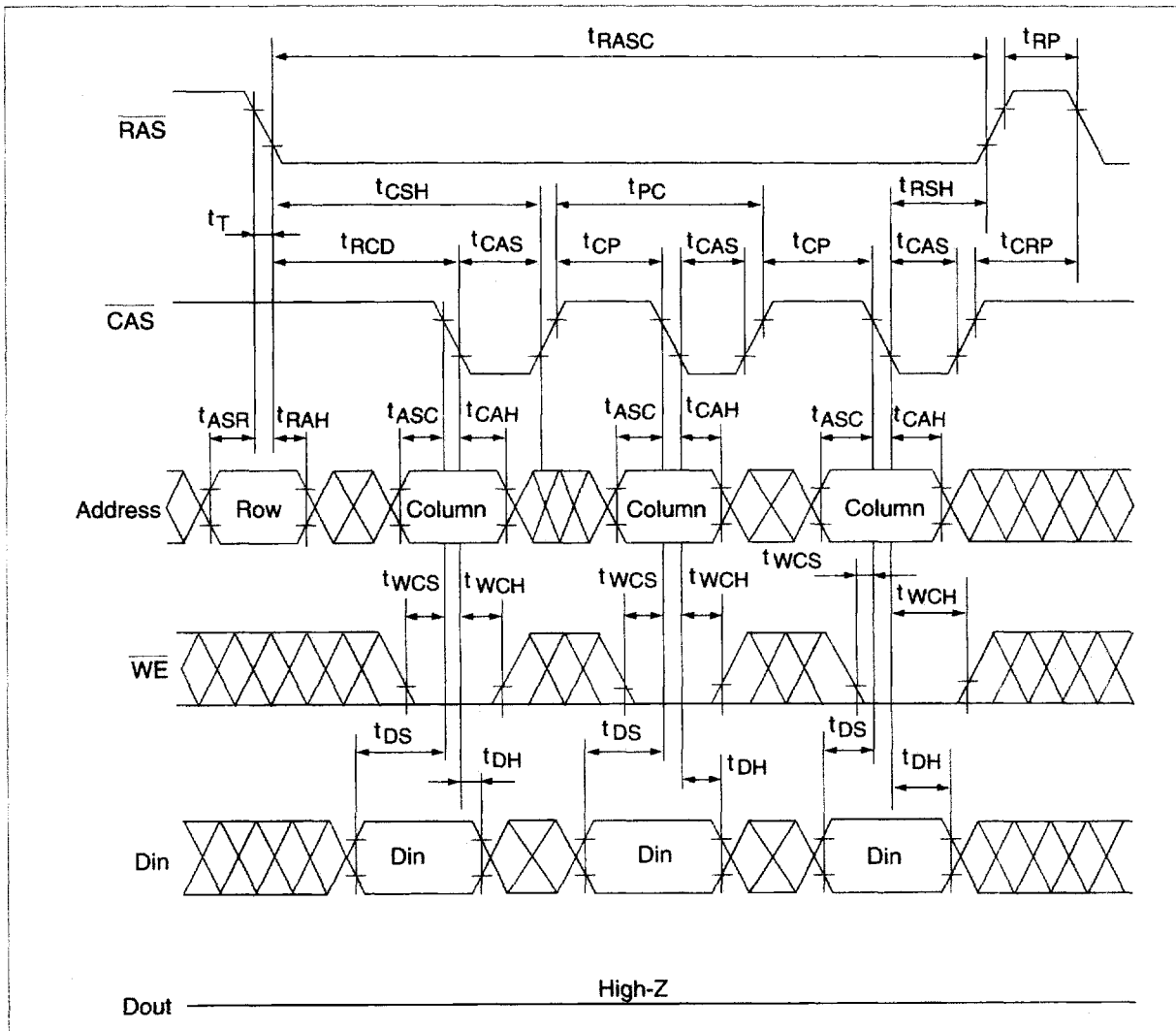





# HM514800C, HM51S4800C Series

Self Refresh Cycle\*<sup>19, 20, 21, 22</sup>

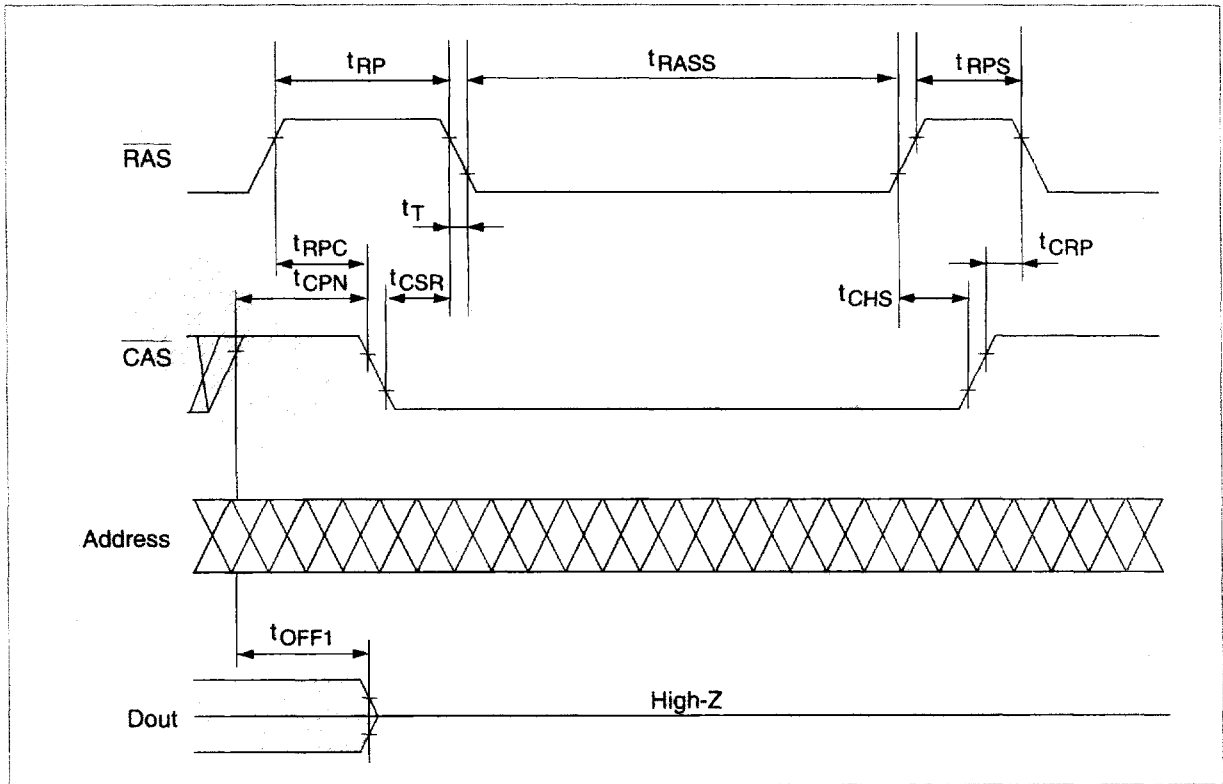

# HM514800C, HM51S4800C Series

## Package Dimensions

HM51(S)4800CJ/CLJ Series (CP-28D)

Unit: mm

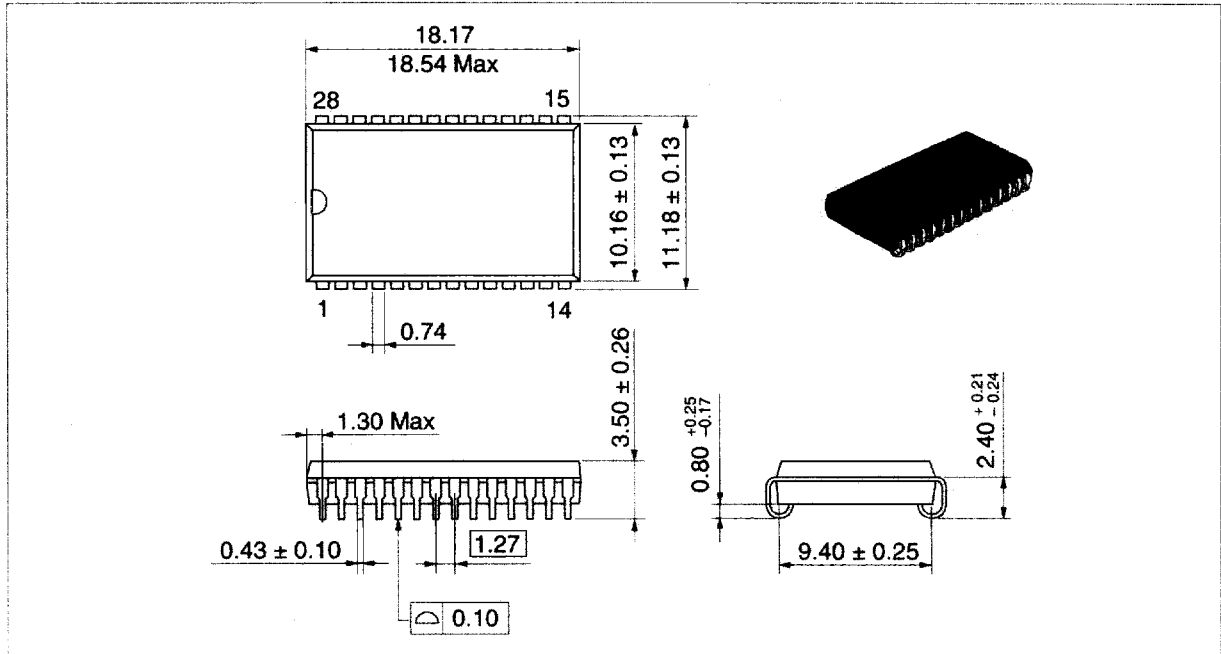

# HM514800C, HM51S4800C Series

HM51(S)4800CTT/CLTT Series (TTP-28D)

Unit: mm

