



# 4-BIT SHIFTER (With 3-State Outputs)

The MC54/74F350 is a specialized multiplexer that accepts a 4-bit word and shifts it 0, 1, 2 or 3 places, as determined by two Select ( $S_0, S_1$ ) inputs. For expansion to longer words, three linking inputs are provided for lower-order bits; thus two packages can shift an 8-bit word, four packages a 16-bit word, etc. Shifting by more than three places is accomplished by paralleling the 3-state outputs of different packages and using the Output Enable ( $\overline{OE}$ ) inputs as a third Select level. With appropriate interconnections, the F350 can perform zero-backfill, sign-extend or end-around (barrel) shift functions.

- Linking Inputs for Word Expansion
- 3-State Outputs for Extending Shift Range

### FUNCTIONAL DESCRIPTION

The F350 is operationally equivalent to a 4-input multiplexer with the inputs connected so that the select code causes successive one-bit shifts of the data word. This internal connection makes it possible to perform shifts of 0, 1, 2 or 3 places on words of any length.

A 7-bit data word is introduced at the  $I_n$  inputs and is shifted according to the code applied to the select inputs  $S_0, S_1$ . Outputs  $O_0-O_3$  are 3-state, controlled by an active-LOW output enable ( $\overline{OE}$ ). When  $\overline{OE}$  is LOW, data outputs will follow selected data inputs; when HIGH, the data outputs will be forced to the high-impedance state. This feature allows shifters to be cascaded on the same output lines or to a common bus. The shift function can be logical, with zeros pulled in at either or both ends of the shifting field; arithmetic, where the sign bit is repeated during a shift down; or end around, where the data word forms a continuous loop.

### LOGIC EQUATIONS

$$O_0 = \overline{S_0} \overline{S_1} I_0 + S_0 \overline{S_1} I_{-1} + \overline{S_0} S_1 I_{-2} + S_0 S_1 I_{-3}$$

$$O_1 = \overline{S_0} \overline{S_1} I_1 + S_0 \overline{S_1} I_0 + \overline{S_0} S_1 I_{-1} + S_0 S_1 I_{-2}$$

$$O_2 = \overline{S_0} \overline{S_1} I_2 + S_0 \overline{S_1} I_1 + \overline{S_0} S_1 I_0 + S_0 S_1 I_{-1}$$

$$O_3 = \overline{S_0} \overline{S_1} I_3 + S_0 \overline{S_1} I_2 + S_0 S_1 I_1 + S_0 S_1 I_0$$

### TRUTH TABLE

Inputs			Outputs			
$\overline{OE}$	$S_1$	$S_0$	$O_0$	$O_1$	$O_2$	$O_3$
H	X	X	Z	Z	Z	Z
L	L	L	$I_0$	$I_1$	$I_2$	$I_3$
L	L	H	$I_{-1}$	$I_0$	$I_1$	$I_2$
L	H	L	$I_{-2}$	$I_{-1}$	$I_0$	$I_1$
L	H	H	$I_{-3}$	$I_{-2}$	$I_{-1}$	$I_0$

H = HIGH Voltage Level      Z = High Impedance  
L = LOW Voltage Level      X = Immaterial

### CONNECTION DIAGRAM

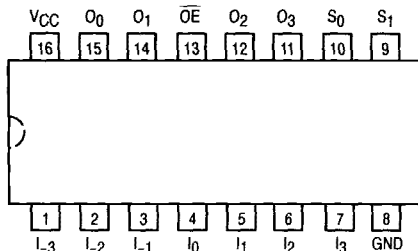

## MC54/74F350

**4-BIT SHIFTER  
(With 3-State Outputs)**  
**FAST™ SCHOTTKY TTL**

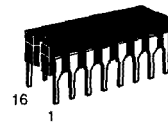

**J SUFFIX**  
CERAMIC  
CASE 620-09

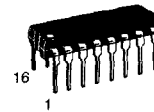

**N SUFFIX**  
PLASTIC  
CASE 648-08

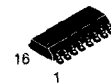

**D SUFFIX**  
SOIC  
CASE 751B-03

### ORDERING INFORMATION

MC54FXXXJ Ceramic  
MC74FXXXN Plastic  
MC74FXXXD SOIC

### LOGIC SYMBOL

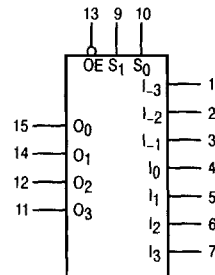

VCC = PIN 16  
GND = PIN 8

# MC54/74F350

## LOGIC DIAGRAM

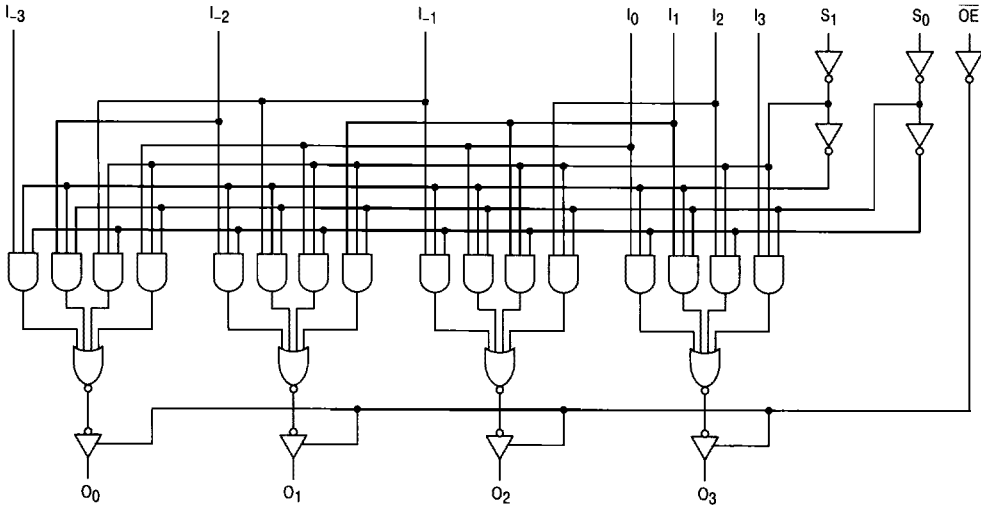

### GUARANTEED OPERATING RANGES

Symbol	Parameter		Min	Typ	Max	Unit
V <sub>CC</sub>	Supply Voltage	54, 74	4.5	5.0	5.5	V
T <sub>A</sub>	Operating Ambient Temperature Range	54	-55	25	125	°C
		74	0	25	70	
I <sub>OH</sub>	Output Current — High	54, 74	—	—	-3.0	mA
I <sub>OL</sub>	Output Current — Low	54, 74	—	—	24	mA

### DC CHARACTERISTICS OVER OPERATING TEMPERATURE RANGE (unless otherwise specified)

Symbol	Parameter	Limits			Unit	Test Conditions	
		Min	Typ	Max			
V <sub>IH</sub>	Input HIGH Voltage	2.0			V	Guaranteed Input HIGH Voltage	
V <sub>IL</sub>	Input LOW Voltage			0.8	V	Guaranteed Input LOW Voltage	
V <sub>IK</sub>	Input Clamp Diode Voltage			-1.2	V	I <sub>IN</sub> = -18 mA	V <sub>CC</sub> = MIN
V <sub>OH</sub>	Output HIGH Voltage	54, 74	2.4	3.3	V	I <sub>OH</sub> = -3.0 mA	V <sub>CC</sub> = 4.5 V
		74	2.7	3.3	V	I <sub>OH</sub> = -3.0 mA	V <sub>CC</sub> = 4.75 V
V <sub>OL</sub>	Output LOW Voltage		0.35	0.5	V	I <sub>OL</sub> = 24 mA	V <sub>CC</sub> = MIN
I <sub>OZH</sub>	Output OFF Current — HIGH			50	μA	V <sub>OUT</sub> = 2.7 V	V <sub>CC</sub> = MAX
I <sub>OZL</sub>	Output OFF Current — LOW			-50	μA	V <sub>OUT</sub> = 0.5 V	V <sub>CC</sub> = MAX
I <sub>IH</sub>	Input HIGH Current			20	μA	V <sub>IN</sub> = 2.7 V	V <sub>CC</sub> = MAX
				100		V <sub>IN</sub> = 7.0 V	
I <sub>IL</sub>	Input LOW Current			-1.2	mA	V <sub>IN</sub> = 0.5 V	V <sub>CC</sub> = MAX
I <sub>OS</sub>	Output Short Circuit Current (Note 2)	-60		-150	mA	V <sub>OUT</sub> = 0 V	V <sub>CC</sub> = MAX
I <sub>CCH</sub>	Power Supply Current		22	35	mA	Outputs HIGH	V <sub>CC</sub> = MAX
I <sub>CCL</sub>			26	41		Outputs LOW	
I <sub>CCZ</sub>			26	42		Outputs OFF	

NOTES: 1. For conditions such as MIN or MAX, use the appropriate value specified under guaranteed operating ranges.  
 2. Not more than one output should be shorted at a time, nor for more than 1 second.

# MC54/74F350

## AC CHARACTERISTICS

Symbol	Parameter	54/74F		54F		74F		Unit
		$T_A = +25^\circ\text{C}$ $V_{CC} = +5.0\text{ V}$ $C_L = 50\text{ pF}$		$T_A = -55\text{ to }+125^\circ\text{C}$ $V_{CC} = 5.0\text{ V} \pm 10\%$ $C_L = 50\text{ pF}$		$T_A = 0\text{ to }+70^\circ\text{C}$ $V_{CC} = 5.0\text{ V} \pm 10\%$ $C_L = 50\text{ pF}$		
		Min	Max	Min	Max	Min	Max	
$t_{PLH}$ $t_{PHL}$	Propagation Delay $I_n$ to $O_n$	3.0 2.5	6.0 5.5	3.0 2.5	7.5 7.0	3.0 2.5	7.0 6.5	ns
$t_{PLH}$ $t_{PHL}$	Propagation Delay $S_n$ to $O_n$	4.0 3.0	10 8.5	4.0 3.0	13.5 10	4.0 3.0	11 9.5	ns
$t_{PZH}$ $t_{PZL}$	Output Enable Time	2.5 4.0	7.0 9.0	2.5 4.0	10.5 11	2.5 4.0	8.0 10	ns
$t_{PHZ}$ $t_{PLZ}$	Output Disable Time	2.0 1.5	5.5 5.5	2.0 1.5	7.0 9.0	2.0 1.5	6.5 6.5	ns

## APPLICATIONS

### 16-Bit Shift-Up 0 to 3 Pieces, Zero Backfill

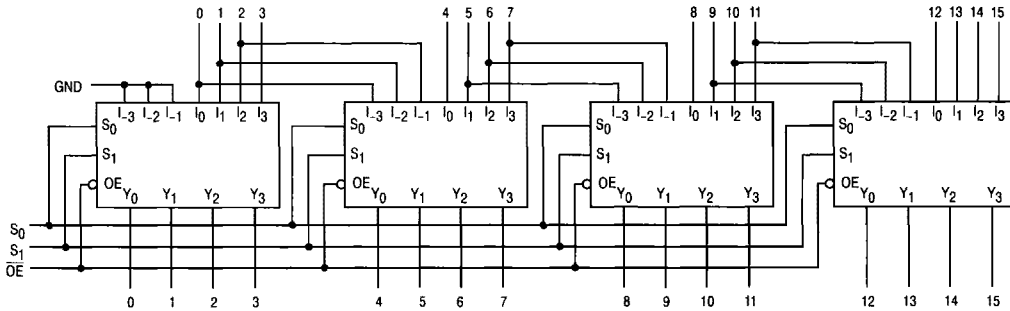

$S_1$	$S_0$	
L	L	NO SHIFT
L	H	SHIFT 1 PLACE
H	L	SHIFT 2 PLACES
H	H	SHIFT 3 PLACES

4

# MC54/74F350

## 8-Bit End Around Shift 0 to 7 Pieces

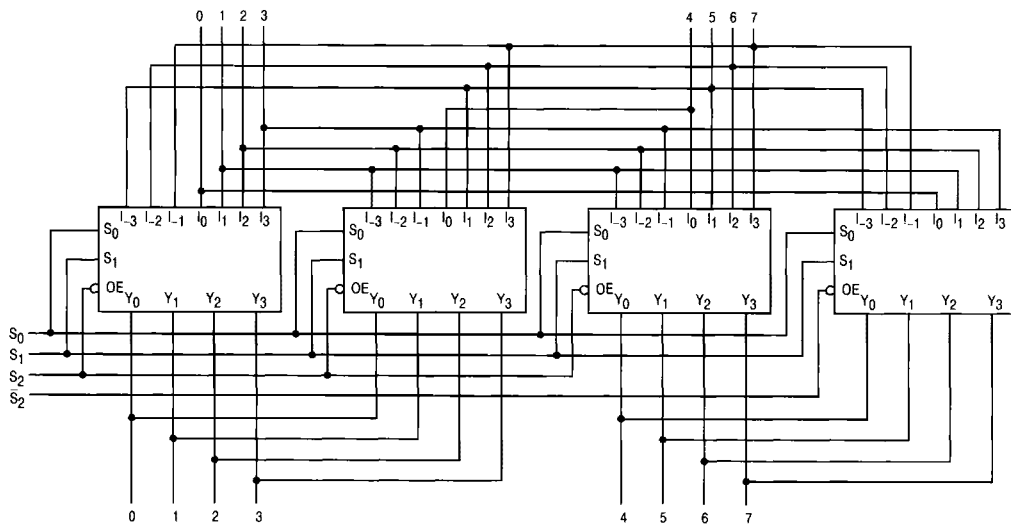

S <sub>2</sub>	S <sub>1</sub>	S <sub>0</sub>	
L	L	L	NO SHIFT
L	L	H	SHIFT END AROUND 1
L	H	L	SHIFT END AROUND 2
L	H	H	SHIFT END AROUND 3
H	L	L	SHIFT END AROUND 4

S <sub>2</sub>	S <sub>1</sub>	S <sub>0</sub>	
H	L	H	SHIFT END AROUND 5
H	H	L	SHIFT END AROUND 6
H	H	H	SHIFT END AROUND 7

## 13-Bit Twos Complement Scaler

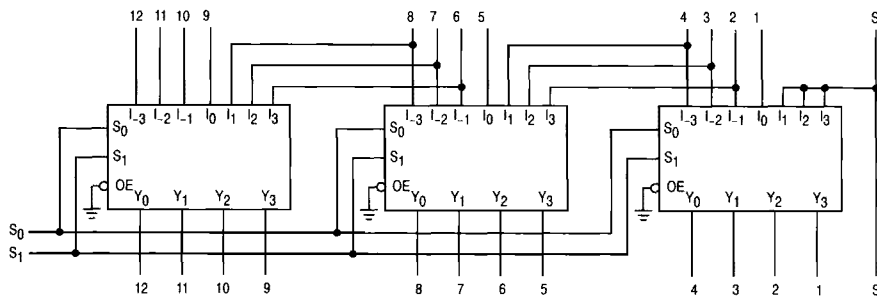

S <sub>1</sub>	S <sub>0</sub>	SCALE
L	L + 8	1/8
L	H + 4	1/4
H	L + 2	1/2
H	H NO CHANGE	1

4