

PRODUCT INFORMATION

PRELIMINARY/β

840nm **2B482**
VCSEL Laser Diode

Datacom

This Vertical Cavity Surface-Emitting Laser is designed for Fibre Channel, Gigabit Ethernet, ATM and general applications. It incorporates a photodiode to monitor the optical power and allow for feedback control.

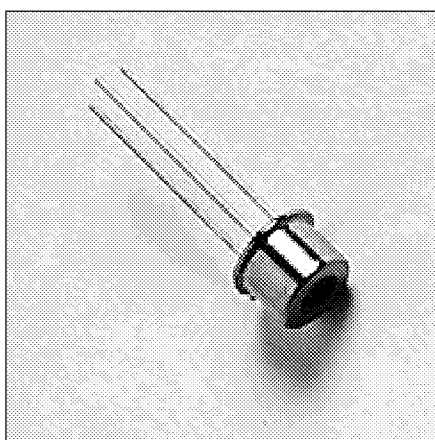

Optical and Electrical Characteristics (25°C Case Temperature)						
PARAMETER	SYMBOL	MIN.	TYP.	MAX.	UNIT	TEST CONDITION
Fiber-Coupled Power	P_{fiber}		1.3		mW	$I_F=12\text{mA}$ (Note 1)
Optical Power	P_O	0.9	1.7	3.0	mW	$I_F=12\text{mA}$
Slope Efficiency (dP_O/dI_F)	η		200		mW/A	$I_F=12\text{mA}$
Beam Divergence	θ		15		deg	Full Width at $1/e^2$
Bandwidth (3dB _{e1})	f_C		2		GHz	$I_F=12\text{mA}$
Peak Wavelength	λ_p	830	840	860	nm	$I_F=12\text{mA}$
Spectral Width (FWHM)	$\Delta\lambda$		0.5	1	nm	$I_F=12\text{mA}$
Forward Voltage	V_F		1.9	2.2	V	$I_F=12\text{mA}$
Threshold Current	I_{th}		3.5	6	mA	
Monitor Current	I_m	20	30		μA	$I_F=12\text{mA}$, $V_R>1\text{V}$
Monitor Dark Current	I_d			30	nA	$V_R=5\text{V}$
Relative Intensity Noise	RIN		-130		dB/Hz	$I_F=12\text{mA}$, $f=1\text{ GHz}$

Note 1: Fiber: 50/125 Graded Index, NA=0.2 or 62.5/125 Graded Index, NA=0.275. An external glass ball lens with 2 mm diameter is required.

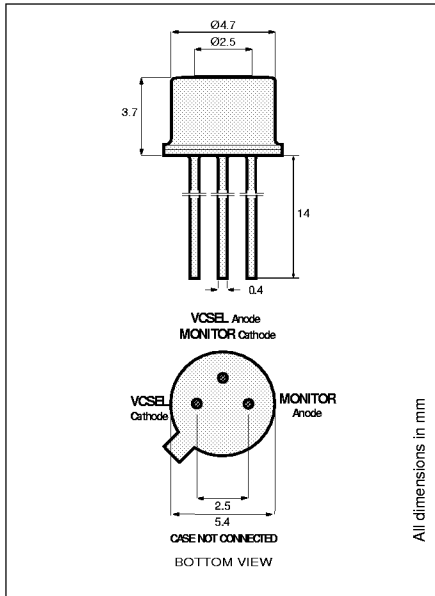

TO-46 Package With Flat Window

WARNING: Laser Radiation, avoid exposure to beam. Class 3B laser product, potential eye hazard. Warning labels in each box.

Absolute Maximum Ratings		
PARAMETER	SYMBOL	LIMIT
Storage Temperature	T_{stg}	-55 to +125°C
Operating Temperature	T_{op}	0 to +70°C
Electrical Power Dissipation	P_{tot}	35 mW
Continuous Forward Current ($f \leq 10\text{ kHz}$)	I_F	15 mA
Peak Forward Current (duty cycle $\leq 50\%$, $f \geq 1\text{ MHz}$)	I_{FRM}	25 mA
VCSEL Reverse Voltage	V_R	1.5 V
Soldering Temperature (2mm from the case for 10 sec)	T_{sld}	260°C

Thermal Characteristics					
PARAMETER	SYMBOL	MIN.	TYP.	MAX.	UNIT
Thermal Resistance - Infinite Heat Sink	R_{thjc}		500		°C/W
Thermal Resistance - No Heat Sink	R_{thja}		800		°C/W
Temp. Coefficient - Wavelength	$d\lambda/dT_j$		0.06		nm/°C
Optical Power - Variation 0 to 70°C	ΔP		± 0.7		dB
Threshold Current - Variation 0 to 70°C	ΔI_{th}		± 0.6		mA

13692.11 1999-01-13



Europe: Tel (46) 8 58 02 45 00 Fax (46) 8 58 02 01 10
 Tel (44) 1291 436180 Fax (44) 1291 436771

America: Tel 1-800-96MITEL Fax (613) 592-6909
 Asia: Tel (65) 293 5312 Fax (65) 293 8527

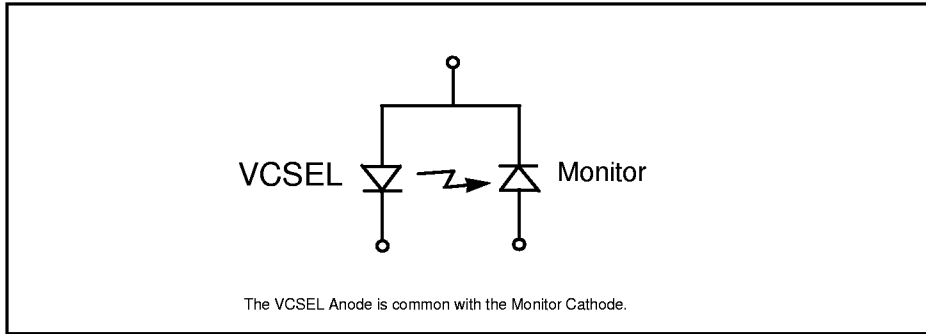

Functional schematic