

Z8038/Z8538 Military FIO FIFO Input/Output Interface Unit

Zilog

Military Electrical Specification

April 1987

Features

- 128-byte FIFO buffer provides asynchronous bidirectional CPU/CPU or CPU/peripheral interface, expandable to any width in byte increments by use of multiple FIOs.
- Interlocked 2-Wire or 3-Wire Handshake logic port mode; Z-BUS® or non-Z-BUS interface.
- Pattern-recognition logic stops DMA transfers and/or interrupts CPU; preset byte count can initiate variable-length DMA transfers.
- Seven sources of vectored/nonvectored interrupt which include pattern-match, byte count, empty or full buffer status; a dedicated "mailbox" register with interrupt capability provides CPU/CPU communication.
- REQUEST/WAIT lines control high-speed data transfers.
- All functions are software controlled via directly addressable read/write registers.

General Description

The Z8038/Z8538 FIO provides an asynchronous 128-byte FIFO buffer between two CPUs or between a CPU and a peripheral device. This buffer interface expands to a 16-bit or wider data path and expands in depth to add as many Z8060 FIFOs (and an additional FIO) as are needed.

The FIO manages data transfers by assuming Z-BUS, non-Z-BUS microprocessor (a generalized microprocessor interface), Interlocked 2-Wire

Handshake, and 3-Wire Handshake operating modes. These modes interface dissimilar CPUs or CPUs and peripherals running under differing speeds or protocols, allowing asynchronous data transactions and improving I/O overhead by as much as two orders of magnitude. Figures 1 and 2 show how the signals controlling these operating modes are mapped to the FIO pins.

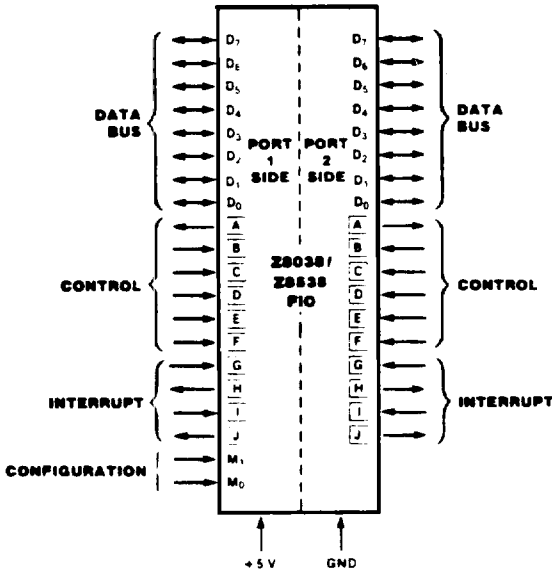

Figure 1. Pin Functions

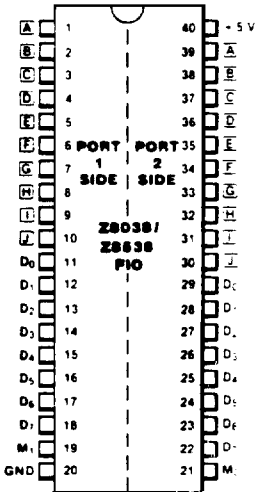

Figure 2a. 40-pin Dual-In-Line Package (DIP) Pin Assignments

ZILG5002

General Description
(Continued)

The FIO supports the Z-BUS interrupt protocols, generating seven sources of interrupts upon any of the following events: a write to a message register, change in data direction, pattern match, status match, over/underflow error, buffer full and buffer empty status. Each interrupt source can be enabled or disabled, and can also place an interrupt vector on the port address/data lines.

The data transfer logic of the FIO has been

especially designed to work with DMA (Direct Memory Access) devices for high-speed transfers. It provides for data transfers to or from memory each machine cycle, while the DMA device generates memory address and control signals. The FIO also supports the variably sized block length, improving system throughput when multiple variable length messages are transferred amongst several sources.

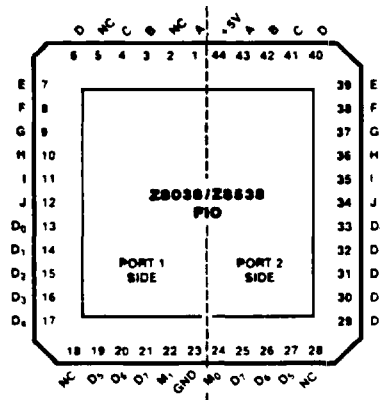

Figure 2b. 44-pin Chip Carrier. Pin Assignments

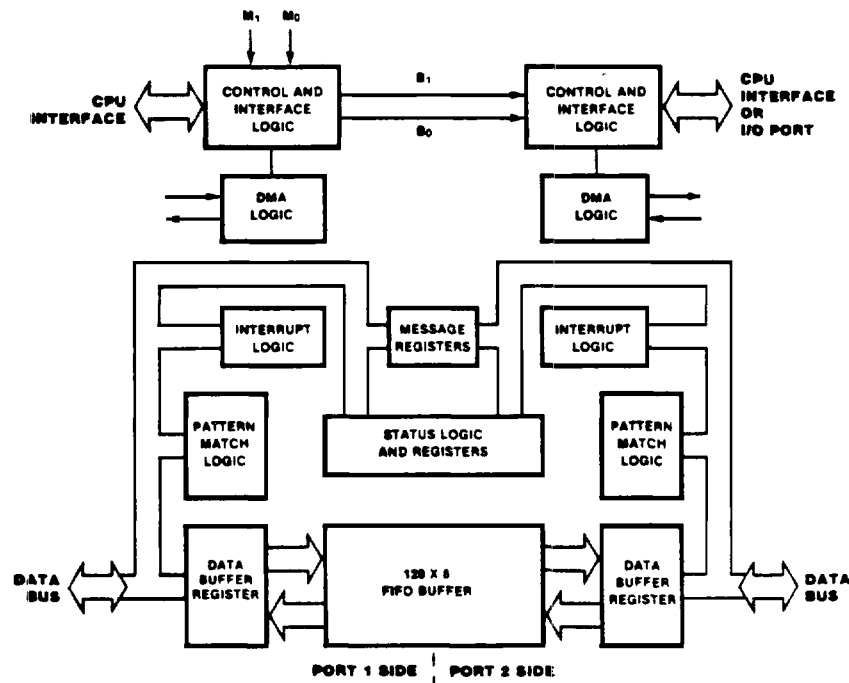

Figure 3. FIO Block Diagram

Functional Description

Operating Modes. Ports 1 and 2 operate in any of twelve combinations of operating modes, listed in Table 2. Port 1 functions in either the Z-BUS or non-Z-BUS microprocessor modes, while Port 2 functions in Z-BUS, non-Z-BUS, Interlocked 2-Wire Handshake, and 3-Wire Handshake modes. Table 1 describes the signals and their corresponding pins in each of these modes.

The pin diagrams of the FIO are identical, except for two pins on the Port 1 side, which select that port's operating mode. Port 2's operating mode is programmed by two bits in Port 1's Control register 0. Table 2 describes the combinations of operating modes; Table 3 describes the control signals mapped to pins A-J in the five possible operating modes.

Signal Pins	Z-BUS Low Byte	Z-BUS High Byte	Non-Z-BUS	Interlocked HS Port*	3-Wire HS Port*
A	REQ/WT	REQ/WT	REQ/WT	RFD/DAV	RFD/DAV
B	DMASTB	DMASTB	DACK	ACKIN	DAV/DAC
C	DS	DS	RD	FULL	DAC/RFD
D	R/W	R/W	WR	EMPTY	EMPTY
E	CS	CS	CE	CLEAR	CLEAR
F	AS	AS	C/D	DATA DIR	DATA DIR
G	INTACK	A ₀	INTACK	IN ₀	IN ₀
H	IEO	A ₁	IEO	OUT ₁	OUT ₁
I	IEI	A ₂	IEI	OE	OE
J	INT	A ₃	INT	OUT ₃	OUT ₃

*2 side only.

Table 1. Pin Assignments

Mode	M ₁	M ₀	B ₁	B ₀	Port 1	Port 2
0	0	0	0	0	Z-BUS Low Byte	Z-BUS Low Byte
1	0	0	0	1	Z-BUS Low Byte	Non-Z-BUS
2	0	0	1	0	Z-BUS Low Byte	3-Wire Handshake
3	0	0	1	1	Z-BUS Low Byte	2-Wire Handshake
4	0	1	0	0	Z-BUS High Byte	Z-BUS High Byte
5	0	1	0	1	Z-BUS High Byte	Non-Z-BUS
6	0	1	1	0	Z-BUS High Byte	3-Wire Handshake
7	0	1	1	1	Z-BUS High Byte	2-Wire Handshake
8	1	0	0	0	Non-Z-BUS	Z-BUS Low Byte
9	1	0	0	1	Non-Z-BUS	Non-Z-BUS
10	1	0	1	0	Non-Z-BUS	3-Wire Handshake
11	1	0	1	1	Non-Z-BUS	2-Wire Handshake

Table 2. Operating Modes

Functional Description
(Continued)

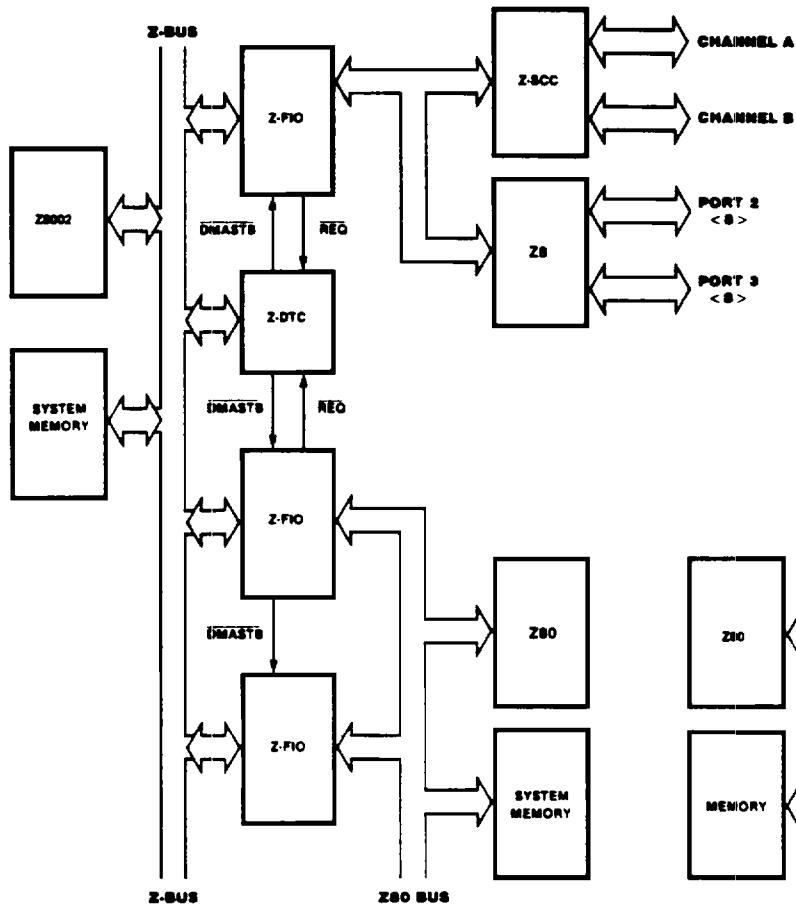

Figure 4. CPU to CPU Configuration

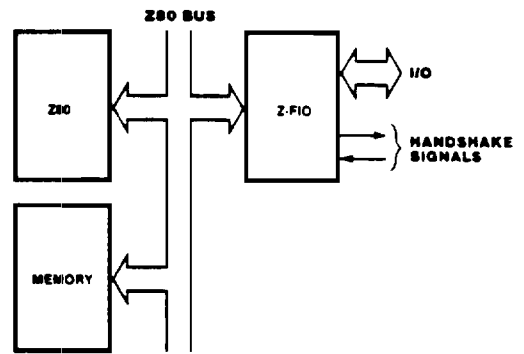

Figure 5. CPU to I/O Configuration

Pins Common To Both Sides	Pin Signals	Pin Names	Pin Numbers		Signal Description
			1	2	
	M ₀	M ₀	21		M ₁ and M ₀ program Port 1 side CPU interface
	M ₁	M ₁	19		
	+5 Vdc	+5 Vdc	40		DC power source
	GND	GND	20		DC power ground

Z-BUS Low Byte Mode	Pin Signals	Pin Names	Pin Numbers Port		Signal Description
			1	2	
Z8038	AD ₀ -AD ₇ (Address/Data)	D ₀ -D ₇	11-18	29-22	Multiplexed bidirectional address/data lines, Z-BUS compatible.
	REQ/WAIT (Request/Wait)	A	1	39	Output, active Low. REQUEST (ready) line for DMA transfer; WAIT line (open-drain) output for syn- chronized CPU and FIO data transfers.
	DMASTB (Direct Memory Access Strobe)	B	2	38	Input, active Low. Strokes DMA data to and from the FIFO buffer.
	DS (Data Strobe)	C	3	37	Input, active Low. Provides timing for data trans- fer to or from FIO.
	R/W (Read/Write)	D	4	36	Input; active High signals CPU read from FIO; active Low signals CPU write to FIO.
	CS (Chip Select)	E	5	35	Input, active Low. Enables FIO. Latched on the rising edge of AS.
	AS (Address Strobe)	F	6	34	Input, active Low. Addresses, CS and INTACK sampled while AS Low.
	INTACK (Interrupt Acknowledge)	G	7	33	Input, active Low. Acknowledges an interrupt. Latched on the rising edge of AS.
	IEO (Interrupt Enable Out)	H	8	32	Output, active High. Sends interrupt enable to lower priority device IEI pin.
	IEI (Interrupt Enable In)	I	9	31	Input, active High. Receives interrupt enable from higher priority device IEO signal.
	INT (Interrupt)	J	10	30	Output, open drain, active Low. Signals FIO inter- rupt request to CPU.

Z-BUS High Byte Mode	Pin Signals	Pin Names	Pin Numbers Port		Signal Description
			1	2	
Z8038	AD ₀ -AD ₇ (Address/Data)	D ₀ -D ₇	11-18	29-22	Multiplexed bidirectional address/data lines, Z-BUS compatible.
	REQ/WAIT (Request/Wait)	A	1	39	Output, active Low. REQUEST (ready) line for DMA transfer; WAIT line (open-drain) output for syn- chronized CPU and FIO data transfers.
	DMASTB (Direct Memory Access Strobe)	B	2	38	Input, active Low. Strokes DMA data to and from the FIFO buffer.
	DS (Data Strobe)	C	3	37	Input, active Low. Provides timing for transfer of data to or from FIO.
	R/W (Read/Write)	D	4	36	Input, active High. Signals CPU read from FIO; active Low signals CPU write to FIO.
	CS (Chip Select)	E	5	35	Input, active Low. Enables FIO. Latched on the rising edge of AS.
	AS (Address Strobe)	F	6	34	Input, active Low. Addresses, CS and INTACK are sampled while AS is Low.
	A ₀ (Address Bit 0)	G	7	33	Input, active High. With A ₁ , A ₂ , and A ₃ , addresses FIO internal registers.
	A ₁ (Address Bit 1)	H	8	32	Input, active High. With A ₀ , A ₂ , and A ₃ , addresses FIO internal registers.
	A ₂ (Address Bit 2)	I	9	31	Input, active High. With A ₀ , A ₁ , and A ₃ , addresses FIO internal registers.
	A ₃ (Address Bit 3)	J	10	30	Input, active High. With A ₀ , A ₁ , and A ₂ , addresses FIO internal registers.

Table 3. Signal/Pin Descriptions

**Non-Z-BUS
Mode**

Z8538

Pin Signals	Pin Names	Pin Numbers		Signal Description
		Port 1	Port 4	
D ₀ -D ₇ (Data)	D ₀ -D ₇	11-18	29-22	Bidirectional data bus.
$\overline{\text{REQ}}/\overline{\text{WT}}$ (Request/Wait)	A	1	39	Output, active Low. REQUEST (ready) line for DMA transfer; WAIT line (open-drain) output for synchronized CPU and FIO data transfer.
$\overline{\text{DACK}}$ (DMA Acknowledge)	B	2	38	Input, active Low. DMA acknowledge.
$\overline{\text{RD}}$ (Read)	C	3	37	Input, active Low. Signals CPU read from FIO.
$\overline{\text{WR}}$ (Write)	D	4	36	Input, active Low. Signals CPU write to FIO.
$\overline{\text{CE}}$ (Chip Select)	E	5	35	Input, active Low. Used to select FIO.
$\text{C}/\overline{\text{D}}$ (Control/Data)	F	6	34	Input, active High. Identifies control byte on D ₀ -D ₇ ; active Low identifies data byte on D ₀ -D ₇ .
$\overline{\text{INTACK}}$ (Interrupt Acknowledge)	G	7	33	Input, active Low. Acknowledges an interrupt.
IEO (Interrupt Enable Out)	H	8	32	Output, active High. Sends interrupt enable to lower priority device IEI pin.
IEI (Interrupt Enable In)	I	9	31	Input, active High. Receives interrupt enable from higher priority device IEO signal.
$\overline{\text{INT}}$ (Interrupt)	J	10	30	Output, open drain, active Low. Signals FIO interrupt to CPU.

**Port 2-I/O
Port Mode**

Pin Signals	Pin Names	Pin Numbers	Mode	Signal Description
D ₀ -D ₇ (Data)	D ₀ -D ₇	29-22	2-Wire HS* 3-Wire HS	Bidirectional data bus.
$\overline{\text{RFD}}/\overline{\text{DAV}}$ (Ready for Data/Data Available)	A	39	2-Wire HS 3-Wire HS	Output. RFD active High. Signals peripherals that FIO is ready to receive data. $\overline{\text{DAV}}$ active Low signals that FIO is ready to send data to peripherals.
$\overline{\text{ACKIN}}$ (Acknowledge Input)	B	38	2-Wire HS	Input, active Low. Signals FIO that output data is received by peripherals or that input data is valid.
$\overline{\text{DAV}}/\overline{\text{DAC}}$ (Data Available/Data Accepted)	B	38	3-Wire HS	Input; $\overline{\text{DAV}}$ (active Low) signals that data is valid on bus. $\overline{\text{DAC}}$ (active High) signals that output data is accepted by peripherals.
FULL	C	37	2-Wire HS	Output, open drain, active High. Signals that FIO buffer is full.
$\overline{\text{DAC}}/\overline{\text{RFD}}$ (Data Accepted/Ready for Data)	C	37	3-Wire HS	Direction controlled by internal programming. Both active High. $\overline{\text{DAC}}$ (an output) signals that FIO has received data from peripheral; $\overline{\text{RFD}}$ (an input) signals that the listeners are ready for data.
EMPTY	D	36	2-Wire HS 3-Wire HS	Output, open drain, active High. Signals that FIFO buffer is empty.
$\overline{\text{CLEAR}}$	E	35	2-Wire HS 3-Wire HS	Programmable input or output, active Low. Clears all data from FIFO buffer.
DATA DIR (Data Direction)	F	34	2-Wire HS 3-Wire HS	Programmable input or output. Active High signals data input to Port 2; Low signals data output from Port 2.
IN ₀	G	33	2-Wire HS 3-Wire HS	Input line to D ₀ of Control Register 3.
OUT ₁	H	32	2-Wire HS 3-Wire HS	Output line from D ₁ of Control Register 3.
$\overline{\text{OE}}$ (Output Enable)	I	31	2-Wire HS 3-Wire HS	Input, active Low. When Low, enables bus drivers. When High, floats bus drivers at high impedance.
OUT ₃	J	30	2-Wire HS 3-Wire HS	Output line from D ₃ of Control register 3.

*Handshake

Table 3. Signal/Pin Descriptions (Continued)

Reset

The FIO can be reset under either hardware or software control by one of the following methods:

- By forcing both \overline{AS} and \overline{DS} Low simultaneously in Z-BUS mode (normally illegal).
- By forcing \overline{RD} and \overline{WR} Low simultaneously in non-Z-BUS mode.
- By writing a 1 to the Reset bit in Control register 0 for software reset.

In the Reset state, all control bits are cleared to 0. Only after clearing the Reset bit (by

writing a 0 to it) can the other command bits be programmed. This action is true for both sides of the FIO when programmed as a CPU interface.

For proper system control, when Port 1 is reset, Port 2 is also reset. In addition, all Port 2's outputs are floating and all inputs are ignored. To initiate the data transfer, Port 2 must be enabled by Port 1. The Port 2 CPU can determine when it is enabled by reading Control register 0, which reads "floating" data bus if not enabled and "01H" if enabled.

CPU Interfaces

The FIO is designed to work with both Z-BUS- and non-Z-BUS-type CPUs on both Port 1 and Port 2. The Z-BUS configuration interfaces CPUs with time-multiplexed address and data information on the same pins. The Z801[®], Z8002[®], and Z8[®] are examples of this type of CPU. The \overline{AS} (Address Strobe) pin is used to latch the address and chip select information sent out by the CPU. The R/ \overline{W} (Read/Write) pin and the \overline{DS} (Data Strobe) pin are used for timing reads and writes from the CPU to

the FIO (Figures 6 and 7).

The non-Z-BUS configuration is used for CPUs where the address and data buses are separate. Examples of this type of CPU are the Z80[®] and the Intel 8080. The \overline{RD} (Read) and \overline{WR} (Write) pins are used to time reads and writes from the CPU to the FIO (Figures 9 and 10). The C/ \overline{D} (Control/Data) pin is used to directly access the FIFO buffer (C/ \overline{D} = 0) and to access the other

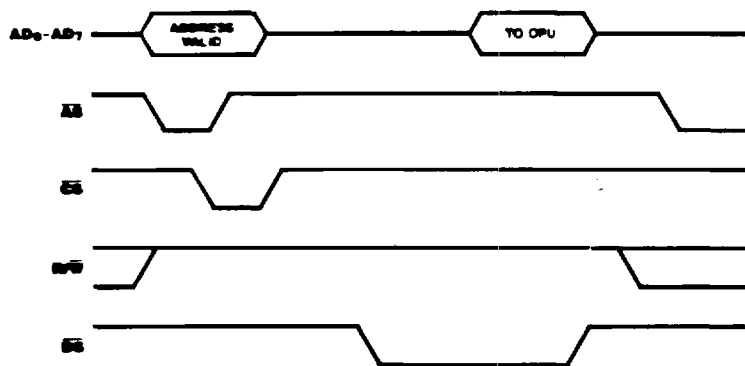

Figure 6. Z-BUS Read Cycle Timing

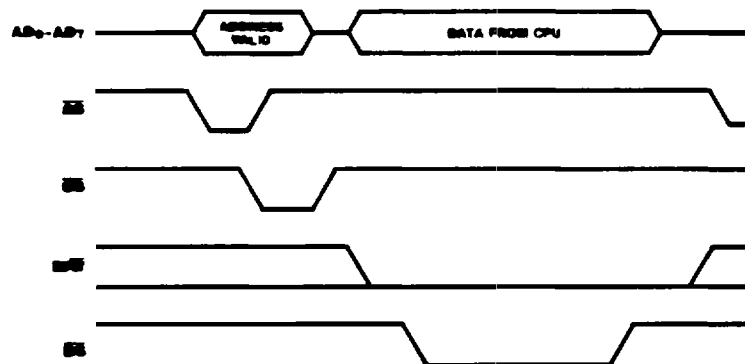

Figure 7. Z-BUS Write Cycle Timing

CPU Interfaces
(Continued)

registers ($C/\overline{D} = 1$). Read and write to all registers except the FIFO buffer¹ are two-step operations, described as follows (Figure 8). First, write the address ($C/\overline{D} = 1$) of the register to be accessed into the Pointer Register (State 0); second, read or write ($C/\overline{D} = 1$) to the register pointed at previously (State 1). Continuous status monitoring can be performed in State 1 by continuous Control Read operations ($C/\overline{D} = 1$).

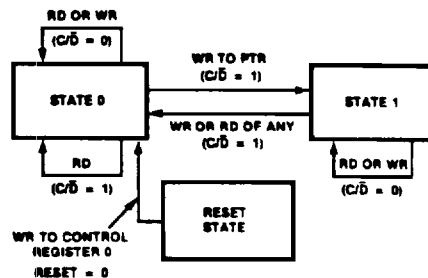

Figure 8. Register Access in Non-Z-BUS Mode

¹The FIFO buffer can also be accessed by this two-step operation.

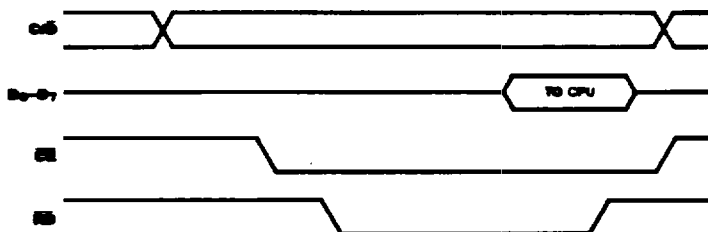

Figure 9. Non-Z-BUS Read Cycle Timing

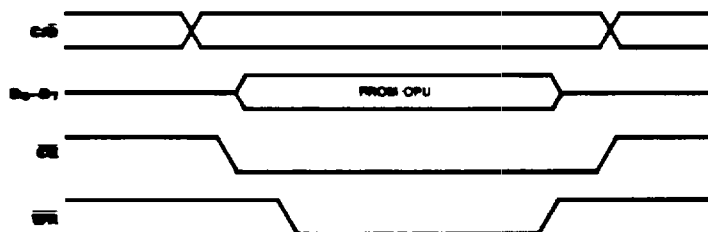

Figure 10. Non-Z-BUS Write Cycle Timing

WAIT Operation

When data is output by the CPU, the $\overline{REQ}/\overline{WT}$ (\overline{WAIT}) pin is active (Low) only when the FIFO buffer is full, the chip is selected, and the FIFO buffer is addressed. \overline{WAIT} goes inactive when the FIFO buffer is not full.

When data is input by the CPU, the $\overline{REQ}/\overline{WT}$ pin becomes active (Low) only when the FIFO buffer is empty, the chip is selected, and the FIFO buffer is addressed. \overline{WAIT} goes inactive when the FIFO buffer is not empty.

Interrupt Operation

The FIO supports Zilog's prioritized daisy chain interrupt protocol for both Z-BUS and non-Z-BUS operating modes (for more details refer to the Zilog *Z-BUS Summary*).

Each side of the FIO has seven sources of interrupt. The priorities of these devices are fixed in the following order (highest to lowest): Mailbox Message, Change in Data Direction, Pattern Match, Status Match, Overflow/

Underflow Error, Buffer Full, and Buffer Empty. Each interrupt source has three bits that control how it generates the interrupt. These bits are Interrupt Pending (IP), Interrupt Enable (IE), and Interrupt Under Service (IUS).

In addition, each side of the FIO has an interrupt vector and four bits controlling the FIO interrupt logic. These bits are Vector

Interrupt Operation
(Continued)

Includes Status (VIS), Master Interrupt Enable (MIE), Disable Lower Chain (DLC), and No Vector (NV).

A typical Interrupt Acknowledge cycle for Z-BUS operation is shown in Figure 11 and for non-Z-BUS operation in Figure 12. The only difference is that in Z-BUS mode, INTACK is latched by \overline{AS} , and in non-Z-BUS mode \overline{INTACK} is not latched.

When MIE = 1, reading the vector always includes status, independent of the state of the

VIS bit. In this way, when VIS = 0, all information can be obtained with one additional read, thus conserving vector space. When MIE = 0, reading the vector register returns the unmodified base vector so that it can be verified.

In non-Z-BUS mode, the IPs do not get set while in State 1. Therefore, to minimize interrupt latency, the FIO should be left in State 0. In Z-BUS mode IPs are set by an \overline{AS} following the event.

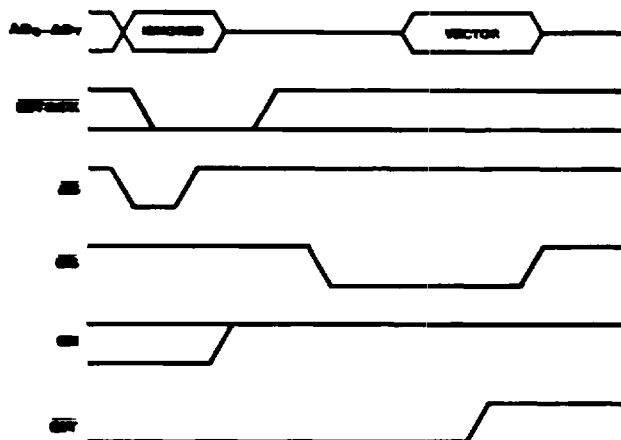

Figure 11. Z-BUS Interrupt Acknowledge Cycle



Figure 12. Non-Z-BUS Interrupt Acknowledge Cycle

CPU to CPU Operation

DMA Operation. The FIO is particularly well suited to work with a DMA in both Z-BUS and non-Z-BUS modes. A data transfer between the FIO and system memory can take place during every machine cycle on both sides of the FIO simultaneously.

In Z-BUS mode, the \overline{DMASTB} pin (DMA Strobe) is used to read or write into the FIFO buffer. The $\overline{R/W}$ (Read/Write) and \overline{DS} (Data Strobe) signals are ignored by the FIO;

however, the \overline{CS} (Chip Select) signal is not ignored and therefore must be kept invalid. Figures 13 and 14 show typical timing.

In Non-Z-BUS mode, the \overline{DACK} pin (DMA Acknowledge) is used to tell the FIO that its DMA request is granted. After \overline{DACK} goes Low, every read or write to the FIO goes into the FIFO buffer. Figures 15 and 16 show typical timing.

**CPU to CPU
Operation
(Continued)**

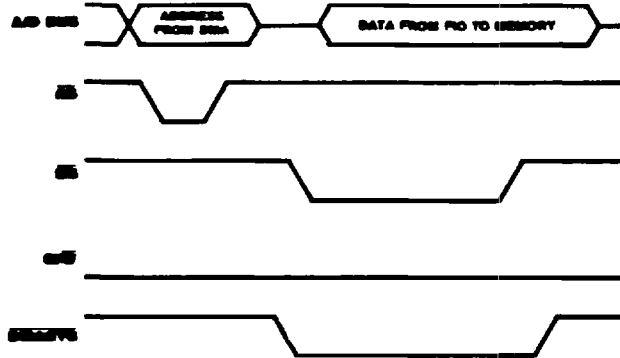

Figure 13. Z-BUS FIO to Memory Data Transaction

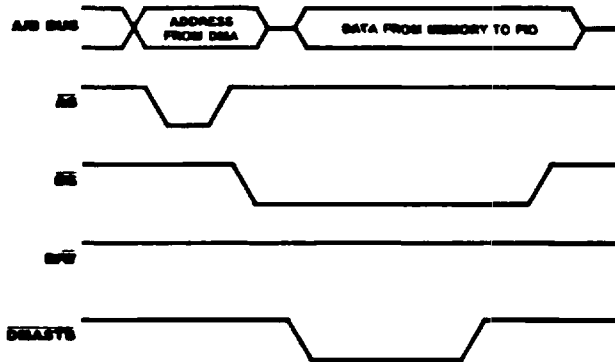

Figure 14. Z-BUS Memory to FIO Data Transaction

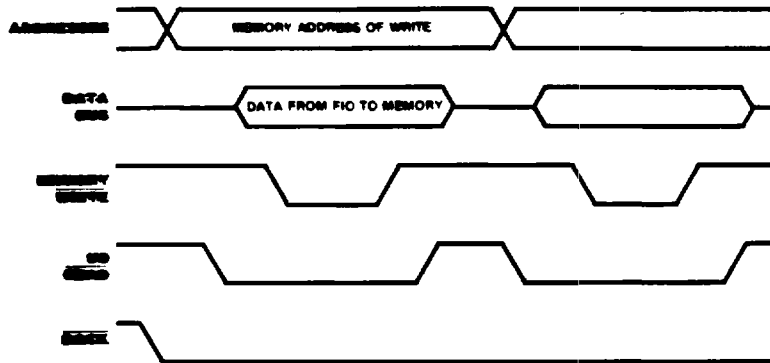

Figure 15. Non-Z-BUS FIO to Memory Transaction

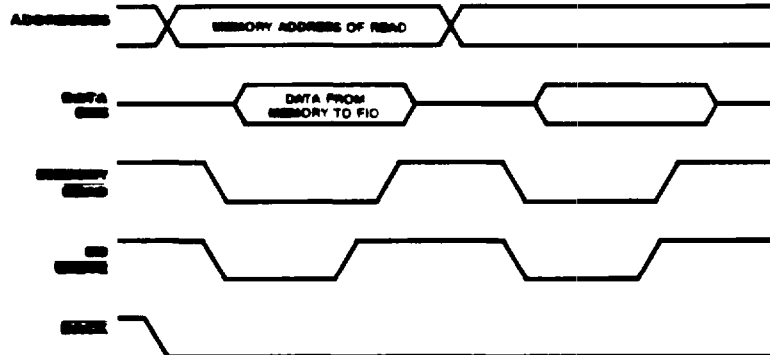
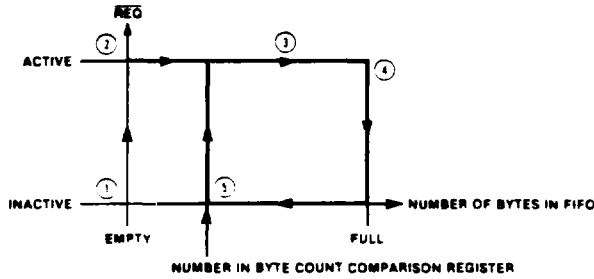

Figure 16. Non-Z-BUS Memory to FIO Data Transaction

CPU to CPU Operation
(Continued)

The FIO provides a special mode to enhance its DMA transfer capability. When data is written into the FIFO buffer, the REQ/WT (REQUEST) pin is active (Low) until the FIFO buffer is full. It then goes inactive and stays inactive until the number of bytes in the FIFO buffer is equal to the value programmed into the Byte Count Comparison register. Then the REQUEST signal goes active and the sequence starts over again (Figure 17).



- NOTES:
1. FIFO empty.
 2. REQUEST enabled, FIO requests DMA transfer.
 3. DMA transfers data into the FIO.
 4. FIFO full, REQUEST inactive.
 5. The FIFO empties from the opposite port until the number of bytes in the FIFO buffer is the same as the number programmed in the Byte Count Comparison register.

Figure 17. Byte Count Control: Write to FIO

When data is read from the FIO, the REQ/WT pin (REQUEST) is inactive until the number of bytes in the FIFO buffer is equal to the value programmed in the Byte Count Comparison register. The REQUEST signal then goes active and stays active until the FIFO buffer is empty. When empty, REQUEST goes inactive and the sequence starts over again (Figure 18).

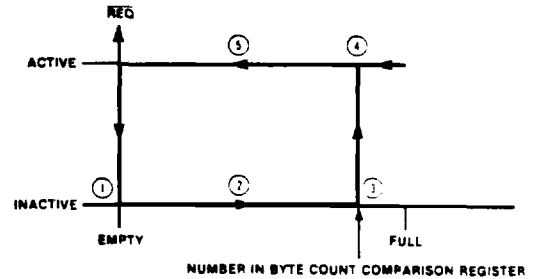

- NOTES:
1. FIFO empty.
 2. CPU/DMA fills FIFO buffer from the opposite port.
 3. Number of bytes in FIFO buffer is the same as the number of bytes programmed in the Byte Count Comparison register.
 4. REQUEST goes active.
 5. DMA transfers data out of FIFO until it is empty.

Figure 18. Byte Count Control: Read from FIO

Message Registers. Two CPUs can communicate through a dedicated "mailbox" register without involving the 128 x 8 bit FIFO buffer (Figure 19). This mailbox approach is useful for transferring control parameters between the interfacing devices on either side of the FIO without using the FIFO buffer. For example, when Port 1's CPU writes to the Message Out register, Port 2's message IP is set. If interrupts are enabled, Port 2's CPU is

interrupted. Port 2's message IP status is readable from the Port 1 side. When Port 2's CPU reads the data from its Message In register, the Port 2 IP is cleared. Thus, Port 1's CPU can read when the message has been read and can now send another message or follow whatever protocol that is set up between the two CPU's. The same transfer can also be made from Port 2's CPU to Port 1's CPU.

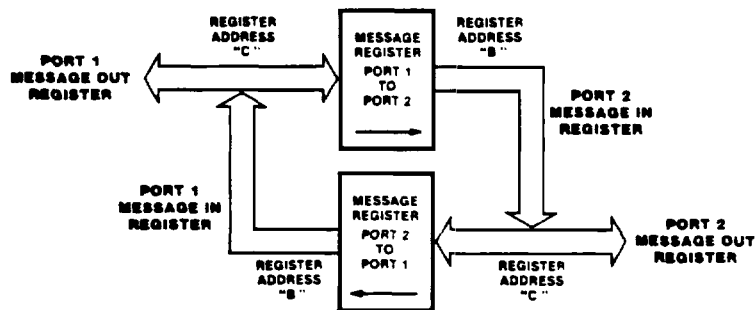

NOTE: Usable only for CPU/CPU interface.

Figure 19. Message Register Operation

CPU to CPU Operation
(Continued)

CLEAR (Empty) FIFO Operation. The $\overline{\text{CLEAR}}$ FIFO bit (active Low) clears the FIFO buffer of data. Writing a 0 to this bit empties the FIFO buffer, inactivates the $\overline{\text{REQUEST}}$ line, and disables the handshake (if programmed). The $\overline{\text{CLEAR}}$ bit does not affect any control or data register. To remove the $\overline{\text{CLEAR}}$ state, write a 1 to the $\overline{\text{CLEAR}}$ bit.

In CPU/CPU mode, under program control, only one of the ports can empty the FIFO by writing to its Control Register 3, bit 6. The Port 1 CPU must program bit 7 in Control Register 3 to determine which port controls the CLEAR FIFO operation (0 = Port 1 control; 1 = Port 2 control).

Direction of Data Transfer Operation. The

Data Direction bit controls the direction of data transfer in the FIFO buffer. The Data Direction bit is defined as 0 = output from CPU and 1 = input to CPU. This bit reads correctly when read by either port's CPU. For example, if Port 1's CPU reads a 0 (CPU output) in its Data Direction bit, then Port 2's CPU reads a 1 (input to CPU) in its Data Direction bit.

In CPU/CPU mode, under program control, only one of the ports can control the direction of data transfer. The Port 1 CPU must program bit 5 in Control Register 3 to determine which port controls the data direction (0 = Port 1 control; 1 = Port 2 control). Figure 20 shows FIO data transfer options.

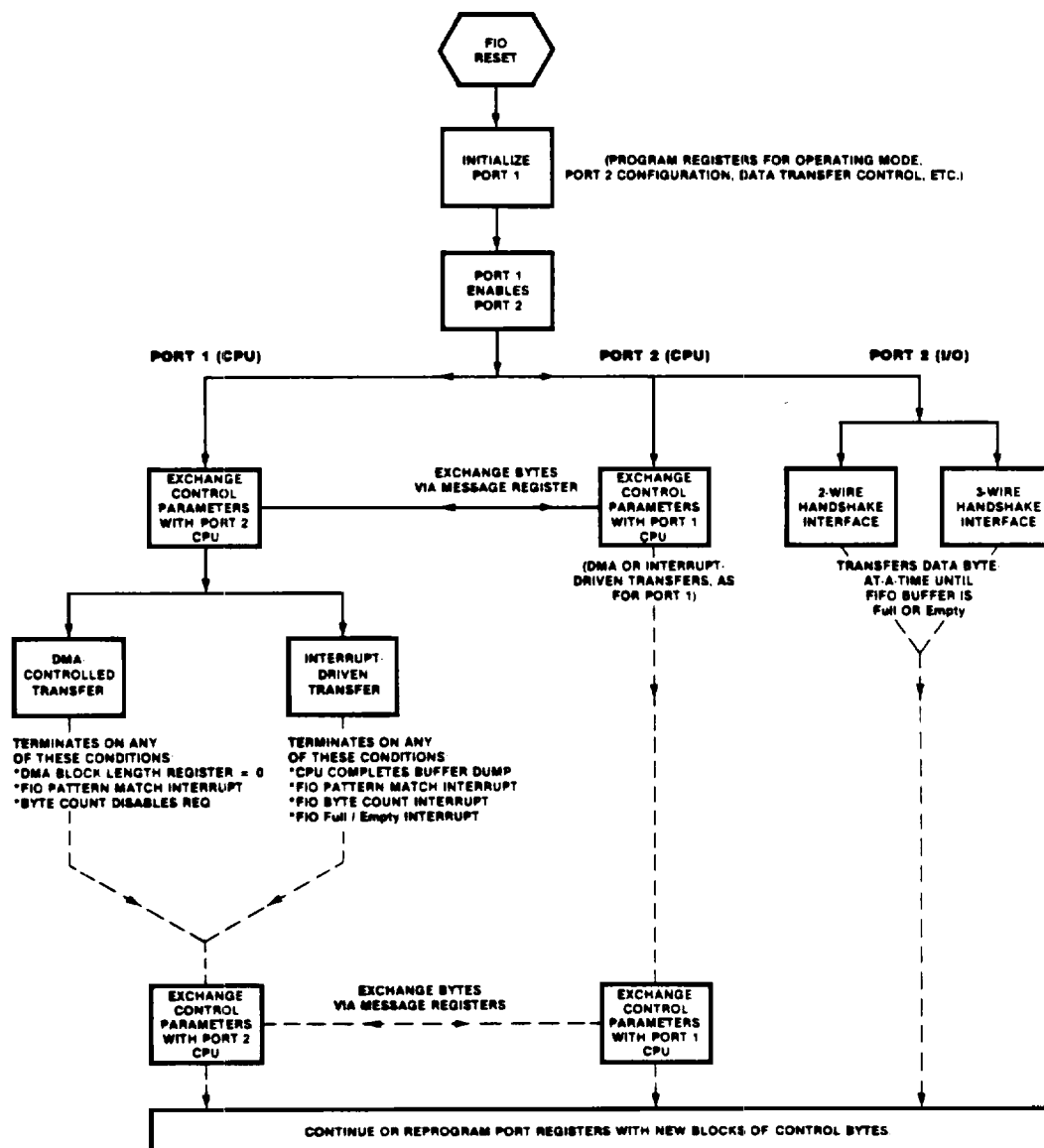

Figure 20. FIO Data Transfer Options

CPU to I/O Operation

When Port 2 is programmed in the Interlocked 2-Wire Handshake mode or the 3-Wire Handshake mode, and Port A is programmed in Z-BUS or non-Z-BUS Microprocessor mode, the FIO interfaces a CPU and a peripheral device. In the Interlocked 2-Wire Handshake mode, $\overline{\text{RFD}}/\overline{\text{DAV}}$ and $\overline{\text{ACKIN}}$ strobe data to and from Port 2. In the 3-Wire Handshake mode, $\overline{\text{RFD}}/\overline{\text{DAV}}$, $\overline{\text{DAV}}/\overline{\text{DAC}}$, and $\overline{\text{DAC}}/\overline{\text{RFD}}$ signals control data flow.

Interlocked 2-Wire Handshake. In the Interlocked Handshake, the action of the FIO must be acknowledged by the other half of the handshake before the next action can take place. In output mode, Port 2 does not indicate that new data is available until the external device indicates it is ready for the data. Similarly, in input mode, Port 2 does not indicate that it is ready for new data until the data source indicates that the previous byte of the data is no longer available, thereby acknowledging Port 2's acceptance of the last byte. This allows the FIO to directly interface to a Z8's port, a CIO's port, a UPC's port, another FIO port, or another FIFO Z8060, with no external logic (Figures 21 and 22).

3-Wire Handshake. The 3-Wire Handshake is designed for applications in which one output port is communicating with many input ports simultaneously. It is essentially the same as the Interlocked Handshake, except that two signals are used to indicate that an input port is ready for new data or that it has accepted the present data. In the 3-Wire Handshake, the rising edge of the $\overline{\text{RFD}}$ status line indicates that the port is ready for data, and the rising edge of the $\overline{\text{DAC}}$ status line indicates that the data has been accepted. With 3-Wire Handshake, the lines of many input ports can be bussed together with open-drain drivers and the out-

put port knows when all of the ports are ready and have accepted the data. This handshake is the same handshake used in the IEEE-488 Instruments. Since the port's direction can be changed under software control, bidirectional IEEE-488-type transfers can be performed. Figures 23 and 24 show the timings associated with 3-Wire Handshake communications.

CLEAR FIFO Operation. In CPU-to-I/O operation, the CLEAR FIFO operation can be performed by the CPU side (Port 1) under software control as previously explained. The CLEAR FIFO operation can also be performed under hardware control by defining the $\overline{\text{CLEAR}}$ pin of Port 2 as an input (Control Register 3, bit 7 = 1).

For cascading purposes, the $\overline{\text{CLEAR}}$ pin can also be defined as an output (Control Register 3, bit 7 = 0), which reflects the current state of the $\overline{\text{CLEAR}}$ FIFO bit. It can then empty other FIOs or initialize other devices in the system.

Data Direction Control. In CPU-to-I/O mode, the direction of data transfer can be controlled by the CPU side (Port 1) under software control as previously explained. The data direction can also be determined by hardware control by defining the Data Direction pin of Port 2 as an input (Control Register 3, bit 5 = 1).

For cascading purposes, the Data Direction pin can also be defined as an output (Control Register 3, bit 5 = 0) pin which reflects the current state of the Data Direction bit. It can then be used to control the direction of data transfer for other FIOs or for external logic.

On the Port 2 side, when data direction is 0, Port 2 is in Output Handshake mode. When data direction is 1, Port 2 is in Input Handshake mode.

**CPU to I/O
Operation
(Continued)**

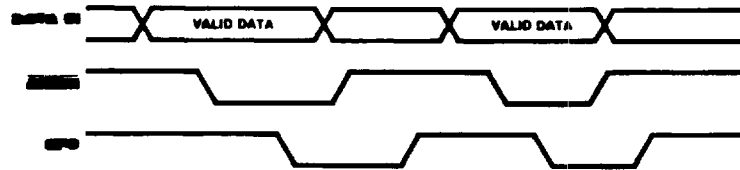

Figure 21. Interlocked Handshake Timing (Input) Port 2 Side Only

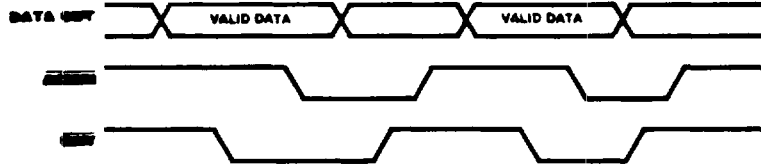

Figure 22. Interlocked Handshake Timing (Output) Port 2 Side Only

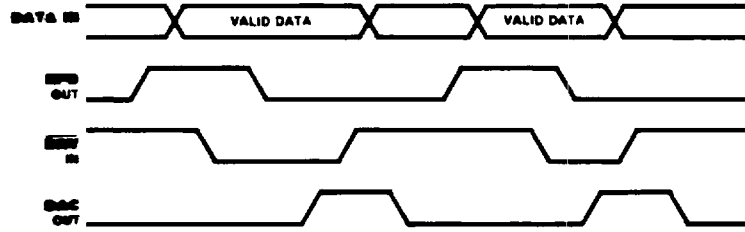

Figure 23. Input (Acceptor) Timing IEEE-488 HS Port: Port 2 Side Only

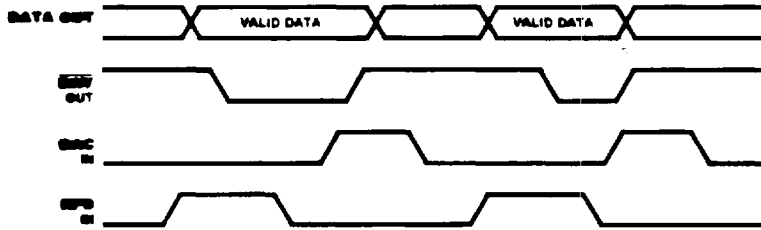

Figure 24. Output (Source) Timing IEEE-488 HS Port: Port 2 Side Only

Programming The programming of the FIO is greatly simplified by the efficient grouping of the various operation modes in the control registers. Since all of the control registers are read/write, the need for maintaining their image in system memory is eliminated. Also, the read/write feature of the registers aids in system debugging.

Each side of the FIO has 16 registers. All 16 registers are used by the Port 1 side; Control register 2 is not used on the Port 2 side. All registers are addressable 0_H through F_H.

In the Z-BUS Low Byte mode, the FIO allows two methods for register addressing under control of the Right Justify Address (RJA) bit in Control register 0. When RJA = 0, address bus bits 1-4 are used for register addressing and bits 1, 5, 6, and 7 are ignored (Table 4). When RJA = 1, bits 0-3 are used for the register addresses, and bits 4-7 are ignored.

Control Registers. These four registers specify FIO operation. The Port 2 side control

registers operate only if the Port 2 device is a CPU. The Port 2 CPU can control interface operations, including data direction, only when enabled by the setting of bit 0 in the Port 1 side of Control Register 2. A 1 in bit 1 of the same register enables the handshake logic.

Interrupt Status Registers. These four registers control and monitor the priority interrupt functions for the FIO.

Interrupt Vector Register. This register stores the interrupt service routine address. This vector is placed on D₀-D₇ when IUS is set by the Interrupt Acknowledge signal from the CPU. When bit 4 (Vector Includes Status) is set in Control Register 0, the reason for the interrupt is encoded within the vector address in bits 1, 2, and 3. If bit 5 is set in Control register 0, no vector is output by the FIO during an Interrupt Acknowledge cycle. However, IUS is set as usual.

	Non Z-BUS	D ₇ -D ₄	D ₃	D ₂	D ₁	D ₀	
	Z-BUS High		A ₃	A ₂	A ₁	A ₀	
Z-BUS Low	$\left\{ \begin{array}{l} \text{RJA}=0 \\ \text{RJA}=1 \end{array} \right.$	$\left\{ \begin{array}{l} \text{AD}_7\text{-AD}_5 \\ \text{AD}_7\text{-AD}_4 \end{array} \right.$	AD ₄ AD ₃	AD ₃ AD ₂	AD ₂ AD ₁	AD ₁ AD ₀	AD ₀
Description							
Control Register 0	x	0	0	0	0	0	x
Control Register 1	x	0	0	0	0	1	x
Interrupt Status Register 0	x	0	0	1	0	0	x
Interrupt Status Register 1	x	0	0	1	1	1	x
Interrupt Status Register 2	x	0	1	0	0	0	x
Interrupt Status Register 3	x	0	1	0	1	1	x
Interrupt Vector Register	x	0	1	1	1	0	x
Byte Count Register	x	0	1	1	1	1	x
Byte Count Comparison Register	x	1	0	0	0	0	x
Control Register 2*	x	1	0	0	1	1	x
Control Register 3	x	1	0	1	0	0	x
Message Out Register	x	1	0	1	1	1	x
Message In Register	x	1	1	0	0	0	x
Pattern Match Register	x	1	1	0	1	1	x
Pattern Mask Register	x	1	1	1	0	0	x
Data Buffer Register	x	1	1	1	1	1	x

x = Don't Care

*Register is only on Port 1 side

Table 4. FIO Register Address Summary

Programming
(Continued)

Byte Count Compare Register. This register contains a value compared with the byte count in the Byte Count register. If the Byte Count Compare interrupt is enabled, an interrupt will occur upon compare.

Message Out Register. Either CPU can place a message in its Message Out register. If the opposite side Message register interrupt is enabled, the receiving side CPU will receive an interrupt request, advising that a message is present in its Message In register. Bit 5 in Control Register 1 on the initiating side is set when a message is written. It is cleared when the message is read by the receiving CPU.

Message In Register. This register receives a message placed in the Message Out register by the opposite side CPU.

Pattern Match Register. This register contains a bit pattern matched against the byte in the

Data Buffer register. When these patterns match, a Pattern Match interrupt will be generated, if previously enabled.

Pattern Mask Register. The Pattern Mask register may be programmed with a bit pattern mask that limits comparable bits in the Pattern Match register to non-masked bits (1 = mask).

Data Buffer Register. This register contains the data to be read from or written to the FIFO buffer.

Byte Count Register. This is a read-only register, containing the byte count for the FIFO buffer. The byte count is derived by subtracting the number of bytes read from the buffer from the number of bytes written into the buffer. The count is "frozen" for an accurate reading by setting bit 6 (Freeze Status register) in Control Register 1. This bit is cleared when the Byte Count register read is completed.

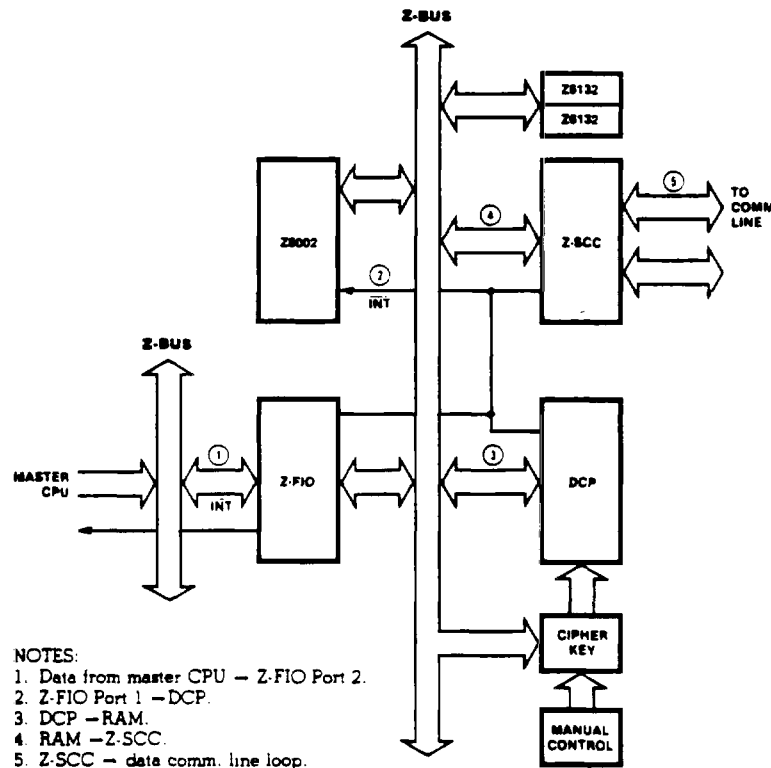
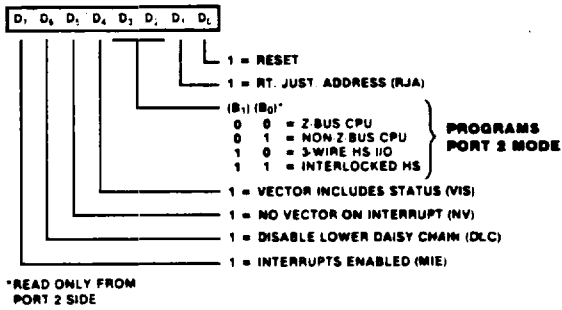

Figure 25. Typical Application: Node Controller

Registers

Control Register 0
Address: 0000
(Read/Write)



Control Register 1
Address: 0001
(Read/Write)

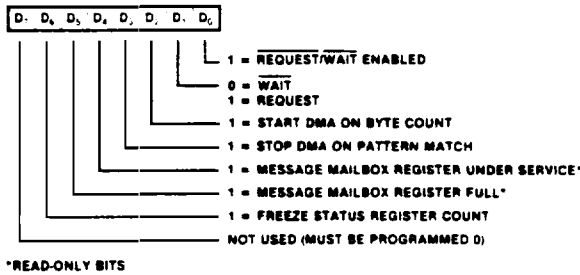

Control Register 2*
Address: 1001
(Read/Write)

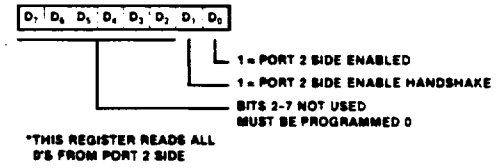

Control Register 3
Address: 1010
(Read/Write)

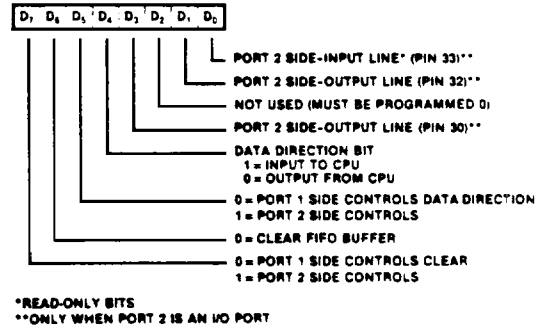

Figure 26. Control Registers

Interrupt Status Register 0
Address: 0010
(Read/Write)

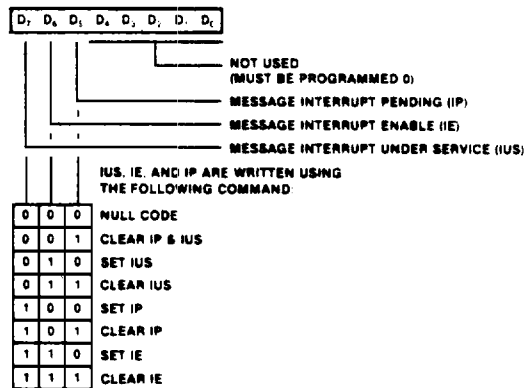
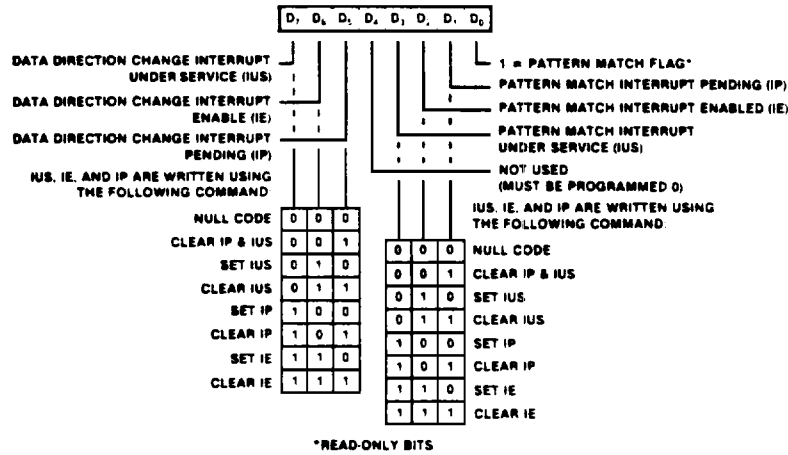
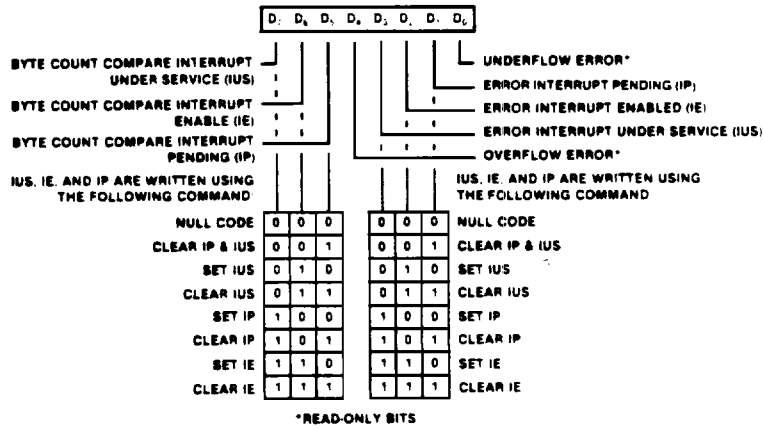

Figure 27. Interrupt Status Registers

Interrupt Status Register 1
Address: 0011
(Read/Write)



Interrupt Status Register 2
Address: 0100
(Read/Write)



Interrupt Status Register 3
Address: 0101
(Read/Write)

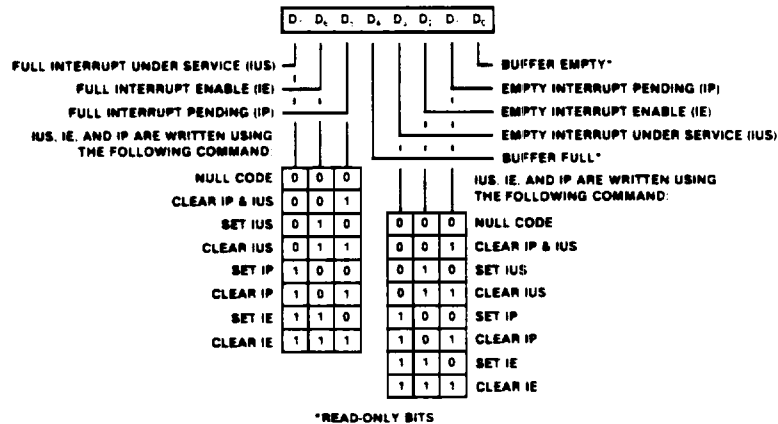

Figure 27. Interrupt Status Registers (Continued)

Registers
(Continued)

Byte Count Register
Address: 0111
(Read Only)

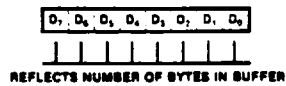

Figure 28. Byte Count Register

Interrupt Vector Register
Address: 0110
(Read/Write)

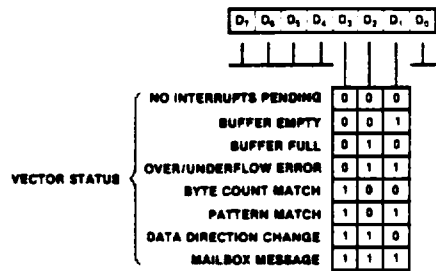

Figure 29. Interrupt Vector Register

Pattern Match Register
Address: 1101
(Read/Write)

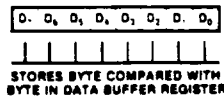

Figure 30. Pattern Match Register

Pattern Mask Register
Address: 1110
(Read/Write)

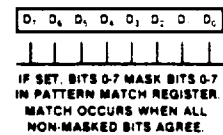

Figure 31. Pattern Mask Register

Data Buffer Register
Address: 1111
(Read/Write)

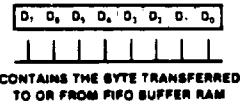

Figure 32. Data Buffer Register

Byte Count Comparison Register
Address: 1000
(Read/Write)

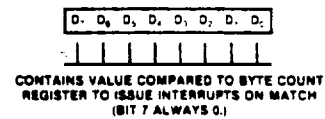

Figure 33. Byte Count Comparison Register

Message Out Register
Address: 1011
(Read/Write)

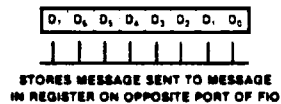

Figure 34. Message Out Register

Message In Register
Address: 1100
(Read Only)

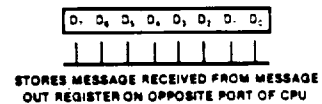

Figure 35. Message In Register

ABSOLUTE MAXIMUM RATINGS

Guaranteed by characterization/design.

Voltages on all pins with respect

to GND	-0.3V to +7V
Operating Case Temperature	-55°C to +125°C
Storage Temperature Range	-65°C to +150°C
Absolute Maximum Power Dissipation	0.20W

Stresses greater than those listed under Absolute Maximum Ratings may cause permanent damage to the device. This is a stress rating only; operation of the device at any condition above those indicated in the operational sections of these specifications is not implied. Exposure to absolute maximum rating conditions for extended periods may affect device reliability.

STANDARD TEST CONDITIONS

The DC Characteristics and Capacitance sections listed below apply for the following standard test conditions, unless otherwise noted. All voltages are referenced to GND. Positive current flows into the referenced pin.

Military Operating Temperature Range (T_C)
-55°C to +125°C

Standard Military Test Condition
 $+4.5V \leq V_{CC} \leq +5.5V$

All AC parameters assume a load capacitance of 50 pf. Add 15 ns delay for each 50 pf increase in load up to a maximum of 200 pf for the data bus. AC timing measurements are referenced to 1.5 volts (except for clock, which is referenced to the 20% and 80% points).

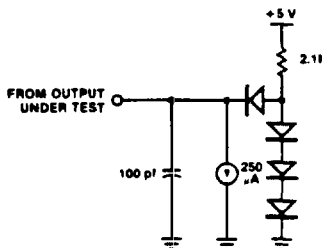

Standard Test Load

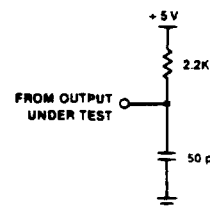

Open-Drain Test Load

DC Characteristics	Symbol	Parameter	Min	Max	Unit	Condition
	V_{IH}	Input High Voltage	2.4	$V_{CC} + 0.3$	V	
	V_{IL}	Input Low Voltage	-0.3	0.8	V	
	V_{OH}	Output High Voltage	2.4		V	$I_{OH} = -250 \mu A$
	V_{OL}	Output Low Voltage		0.4	V	$I_{OL} = +2.0 \text{ mA}$
				0.5	V	$I_{OL} = +3.2 \text{ mA}$
	I_{IL}	Input Leakage	-10.0	+10.0	μA	$0.4 \leq V_{IN} \leq +2.4V$
	I_{OL}	Output Leakage	-10.0	+10.0	μA	$0.4 \leq V_{OUT} \leq +2.4V$
	I_{LM}	Mode Pins Input Leakage (Pins 19 and 21)	-100	+10.0	μA	$0 < V_{IN} < V_{CC}$
	I_{CC}	V_{CC} Supply Current		350	mA	

$V_{CC} = 5V \pm 10\%$ unless otherwise specified, over specified temperature range.

Capacitance	Symbol	Parameter	Min	Max	Unit	Condition
	C_{IN}	Input Capacitance		10	pf	
	C_{OUT}	Output Capacitance		15	pf	
	$C_{I/O}$	Bidirectional Capacitance		20	pf	

Unmeasured pins returned to ground.

Inputs	Symbol	Parameter	Min	Max	Unit	Condition
	t_r	Any Input Rise Time		100	ns	
	t_f	Any Input Fall Time		100	ns	

$f = 1 \text{ MHz}$, over specified temperature range.

AC Characteristics

No.	Symbol	Parameter	4 MHz		6 MHz		Notes††
			Min	Max	Min	Max	
1	T_{wAS}	\overline{AS} Low Width	70		50		1
2	$T_{sA(AS)}$	Address to \overline{AS} ↑ Setup Time	30		10		1
3	$T_{hA(AS)}$	Address to \overline{AS} ↓ Hold Time	50		30		1
4	$T_{sCSO(AS)}$	\overline{CS} to \overline{AS} ↑ Setup Time	0		0		1
5	$T_{hCSO(AS)}$	\overline{CS} to \overline{AS} ↓ Hold Time	60		40		1
6	$T_{dAS(DS)}$	\overline{AS} ↑ to \overline{DS} ↓ Delay	60		40		1
7	$T_{sA(DS)}$	Address to \overline{DS} ↓ (with \overline{AS} ↑ to \overline{DS} ↓ = 60 ns)	120		100		
8	$T_{sRWR(DS)}$	R/ \overline{W} (Read) to \overline{DS} ↓ Setup Time	100		80		
9	$T_{sRWW(DS)}$	R/ \overline{W} (Write) to \overline{DS} ↓ Setup Time	0		0		
10	T_{wDS}	\overline{DS} Low Width	390		250		
11	$T_{sDW(DSf)}$	Write Data to \overline{DS} ↓ Setup Time	30		20		
12	$T_{dDS(DRV)}$	\overline{DS} (Read) ↓ to Address Data Bus Driven	0		0		
13	$T_{dDSf(DR)}$	\overline{DS} ↓ to Read Data Valid Delay		250		180	
14	$T_{hDW(DS)}$	Write Data to \overline{DS} ↓ Hold Time	30		20		
15	$T_{dDSr(DR)}$	\overline{DS} ↑ to Read Data Not Valid Delay	0		0		
16	$T_{dDS(DRz)}$	\overline{DS} ↑ to Read Data Float Delay		70		45	2
17	$T_{hRW(DS)}$	R/ \overline{W} to \overline{DS} ↑ Hold Time	55		40		
18	$T_{dDS(AS)}$	\overline{DS} ↑ to \overline{AS} ↓ Delay	50		25		
19	T_{rc}	Valid Access Recovery Time	1000		650		3

NOTES:

- Parameter does not apply to Interrupt/Acknowledge transactions.
- Float delay is measured to the time when the output has changed 0.5V from steady state with minimum ac load and maximum dc load.

- This is the delay from \overline{DS} of one FIO access to \overline{DS} of another FIO access (either read or write).

* All timing references assume 2.0V for a logic "1" and 0.8V for a logic "0". All timings are preliminary and subject to change.
 † Units in nanoseconds (ns).

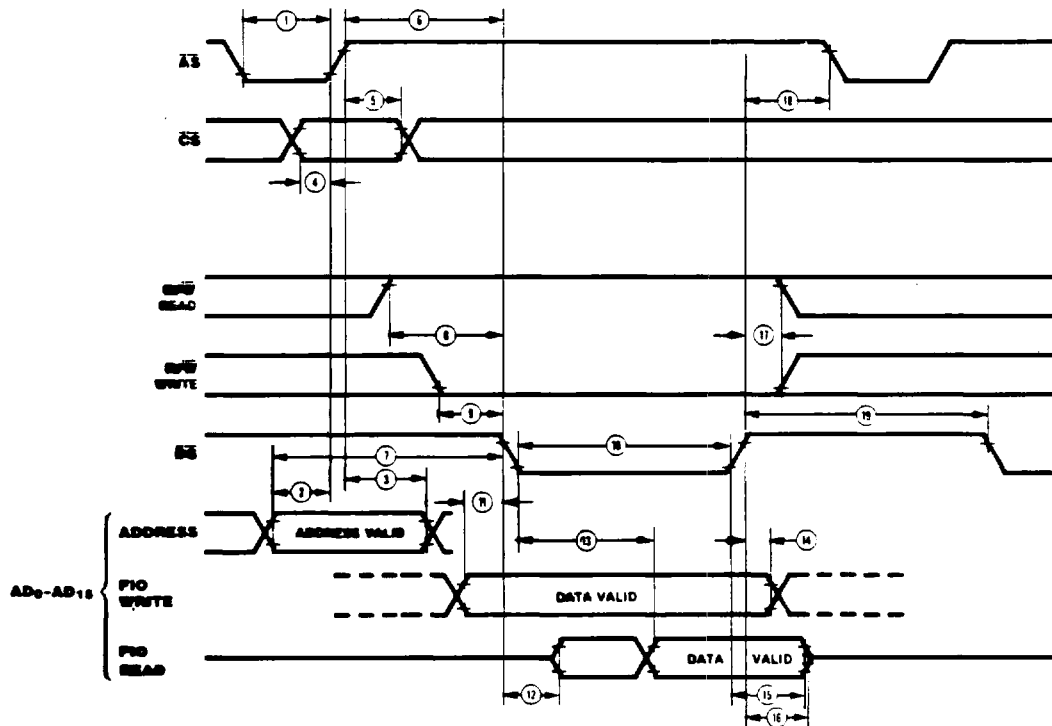

Figure 36. Z-BUS CPU Interface Timing

AC Characteristics

No.	Symbol	Parameter	4 MHz		6 MHz		Notes*†
			Min	Max	Min	Max	
20	TsIA(AS)	$\overline{\text{INTACK}}$ to $\overline{\text{AS}}$ ↑ Setup Time	0		0		
21	ThIA(AS)	$\overline{\text{INTACK}}$ to $\overline{\text{AS}}$ ↓ Hold Time	250		250		
22	TsDSA(DR)	$\overline{\text{DS}}$ (Acknowledge) ↓ to Read Data Valid Delay		250		180	
23	TwDSA	$\overline{\text{DS}}$ (Acknowledge) Low Width	390		250		
24	TdAS(IEO)	$\overline{\text{AS}}$ ↑ to IEO ↓ Delay ($\overline{\text{INTACK}}$ Cycle)		350		250	4
25	TdIEI(IEO)	IEI to IEO Delay		150		100	4
26	TsIEI(DSA)	IEI to $\overline{\text{DS}}$ (Acknowledge) ↓ Setup Time	100		70		
27	ThIEI(DSA)	IEI to $\overline{\text{DS}}$ (Acknowledge) ↓ Hold Time	50		30		4
28	TdDS(INT)	$\overline{\text{DS}}$ ($\overline{\text{INTACK}}$ Cycle) to $\overline{\text{INT}}$ Delay		900		800	
29	TdDCST	Interrupt Daisy Chain Settle Time					4

NOTES

4. The parameters for the devices in any particular daisy chain must meet the following constraint: The delay from $\overline{\text{AS}}$ to $\overline{\text{DS}}$ must be greater than the sum of TdAS(IEO) for the highest priority peripheral, TsIEI(DSA) for the lowest priority peripheral

and TdIEI(IEO) for each peripheral, separating them in the chain.

* Timings are preliminary and subject to change
† Units in nanoseconds (ns)

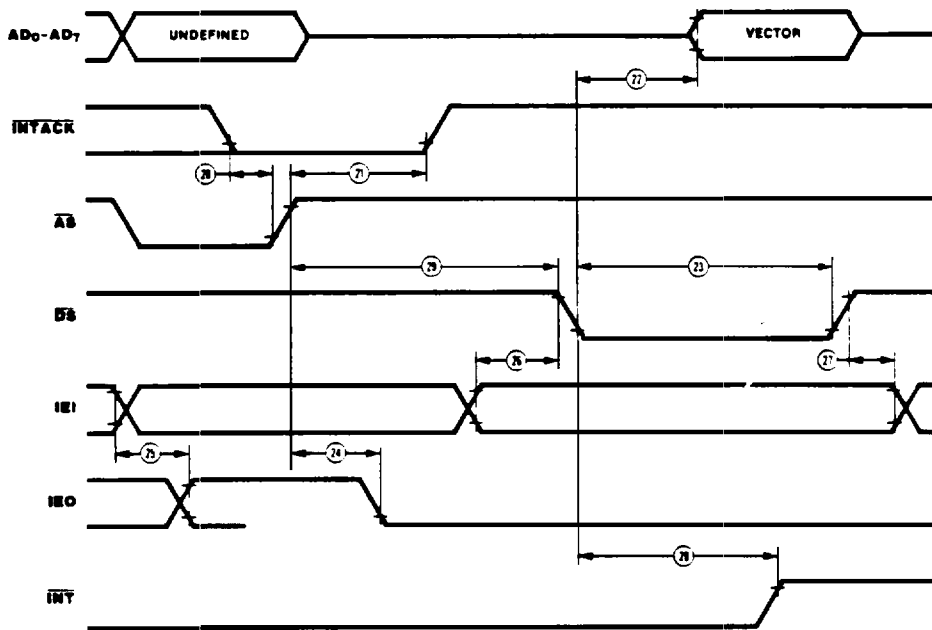

Figure 37. Z-BUS CPU Interrupt Acknowledge Timing

AC Characteristics

No.	Symbol	Parameter	4 MHz		6 MHz		Notes**†
			Min	Max	Min	Max	
30	TdMW(INT)	Message Write to $\overline{\text{INT}}$ Delay		1		1	5
31	TdDC(INT)	Data Direction Change to $\overline{\text{INT}}$ Delay		1		1	6
32	TdPMW(INT)	Pattern Match to $\overline{\text{INT}}$ Delay (Write Case)		1		1	
33	TdPMR(INT)	Pattern Match (Read Case) to $\overline{\text{INT}}$ Delay		1		1	
34	TdSC(INT)	Status Compare to $\overline{\text{INT}}$ Delay		1		1	6
35	TdER(INT)	Error to $\overline{\text{INT}}$ Delay		1		1	
36	TdEM(INT)	Empty to $\overline{\text{INT}}$ Delay		1		1	6
37	TdFL(INT)	Full to $\overline{\text{INT}}$ Delay		1		1	6
38	TdAS(INT)	$\overline{\text{AS}}$ to $\overline{\text{INT}}$ Delay					

NOTES:

5. Write is from the other side of FIO.
 6. Write can be from either side depending on programming of FIO.

* Timings are preliminary and subject to change.
 † Units equal to AS Cycles + ns.

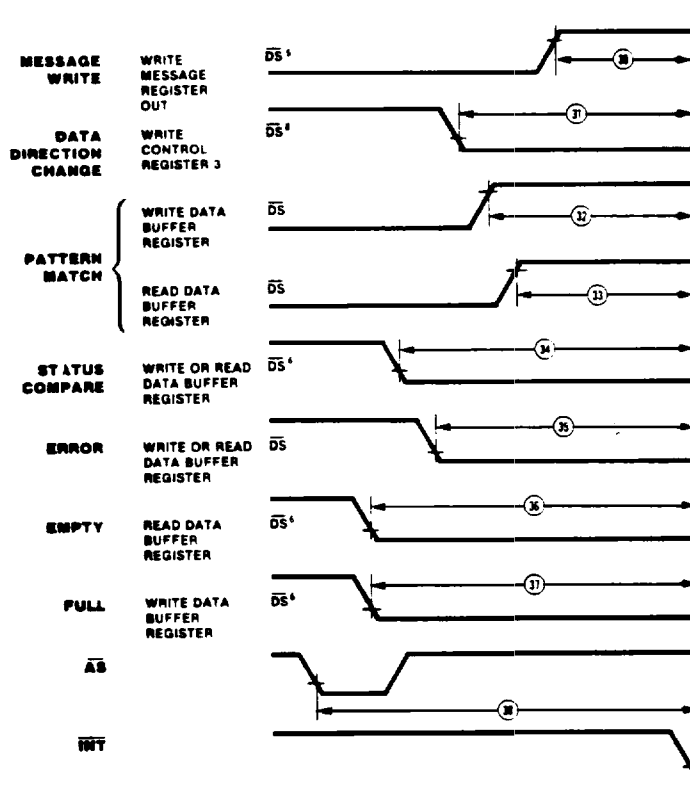

Figure 38. Z-BUS Interrupt Timing

AC Characteristics

No.	Symbol	Parameter	4 MHz		6 MHz		Notes*†
			Min	Max	Min	Max	
1	TdDS(WAIT)	\overline{AS} ↓ to \overline{WAIT} ↓ Delay		190		160	
2	TdDS1(WAIT)	\overline{DS} ↓ to \overline{WAIT} ↓ Delay		1000		1000	
3	TdACK(WAIT)	\overline{ACKIN} ↓ to \overline{WAIT} ↓ Delay		1000		1000	1
4	TdDS(REQ)	\overline{DS} ↓ to \overline{REQ} ↓ Delay		350		300	
5	TdDMA(REQ)	\overline{DMASTB} ↓ to \overline{REQ} ↓ Delay		350		300	
6	TdDS1(REQ)	\overline{DS} ↓ to \overline{REQ} ↓ Delay		1000		1000	
7	TdACK(REQ)	\overline{ACKIN} ↓ to \overline{REQ} ↓ Delay		1000		1000	
8	TdSU(DMA)	Data Setup Time to \overline{DMASTB}	200		150		
9	TdH(DMA)	Data Hold Time to \overline{DMASTB}	30		20		
10	TdDMA(DR)	\overline{DMASTB} ↓ to Valid Data		150		100	
11	TdDMA(DRH)	\overline{DMASTB} ↓ to Data Not Valid	0		0		
12	TdDMA(DR2)	\overline{DMASTB} ↓ to Data Bus Float		70		45	

NOTES:

1. The delay is from \overline{DAV} for 3-Wire Input Handshake. The delay is from \overline{DAC} for 3-Wire Handshake.

* Timings are preliminary and subject to change.
† Units in nanoseconds (ns).

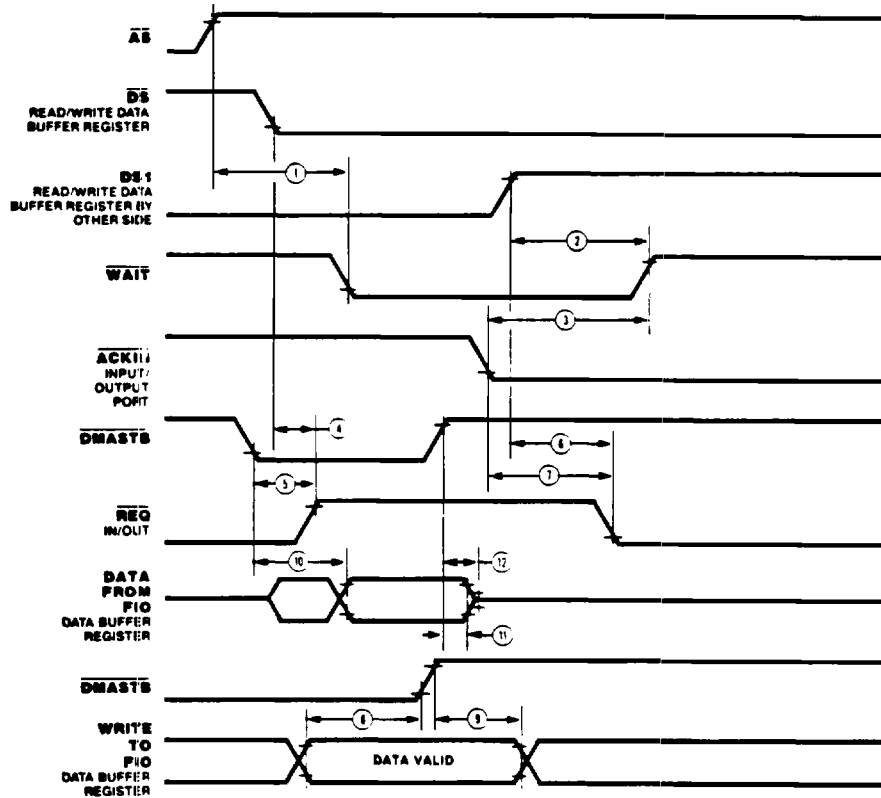

Figure 39. Z-BUS Request/Wait Timing

AC Characteristics

No.	Symbol	Parameter	4 MHz		6 MHz		Notes*†
			Min	Max	Min	Max	
1	TdDSQ(AS)	Delay from \overline{DS} ↓ to \overline{AS} ↓ for No Reset	40		20		
2	TdASQ(DS)	Delay for \overline{AS} ↓ to \overline{DS} ↓ for No Reset	50		30		
3	Tw(AS + DS)	Minimum Width of \overline{AS} and \overline{DS} Both Low for Reset.	500		350		1

NOTES:

1. Internal circuitry allows for the reset provided by the Z8 (\overline{DS} held Low while \overline{AS} pulses) to be sufficient.

* Timings are preliminary and subject to change.
† Units in nanoseconds (ns).



Figure 40. Z-BUS Reset Timing

AC Characteristics

No.	Symbol	Parameter	4 MHz		6 MHz		Notes††
			Min	Max	Min	Max	
1	TsA(RD)	Address Setup to \overline{RD} †	80		80		1
2	TsA(WR)	Address Setup to \overline{WR} †	80		80		
3	ThA(RD)	Address Hold Time to \overline{RD} †	0		0		1
4	ThA(WR)	Address Hold Time to \overline{WR} †	0		0		
5	TsCEI(RD)	\overline{CE} Low Setup Time to \overline{RD}	0		0		1
6	TsCEI(WR)	\overline{CE} Low Setup Time to \overline{WR}	0		0		
7	ThCEI(RD)	\overline{CE} Low Hold Time to \overline{RD}	0		0		1
8	ThCEI(WR)	\overline{CE} Low Hold Time to \overline{WR}	0		0		
9	TsCEh(RD)	\overline{CE} High Setup Time to \overline{RD}	100		70		1
10	TsCEh(WR)	\overline{CE} High Setup Time to \overline{WR}	100		70		
11	TwRD1	\overline{RD} Low Width	390		250		
12	TdRD(DRA)	\overline{RD} † to Read Data Active Delay	0		0		
13	TdRDf(DR)	\overline{RD} † to Valid Data Delay		250		180	
14	TdRDv(DR)	\overline{RD} † to Read Data Not Valid Delay	0		0		
15	TdRD(DRz)	\overline{RD} † to Data Bus Float		70		45	2
16	TwWR1	\overline{WR} Low Width	390		250		
17	TsDW(WR)	Data Setup Time to \overline{WR}	0		0		
19	Trc(WR)	Write Valid Access Recovery Time	1000		650		
20	Trc(RD)	Read Valid Access Recovery Time	1000 + WR _p		650 + WR _p		3

NOTES:

- Parameter does not apply to Interrupt Acknowledge transactions.
 - Float delay is measured to the time the output has changed 0.5V from steady state with minimum ac load and maximum dc load.
 - Recovery time equal to Trc(WR) + write pulse width of the opposite side.
- * Timings are preliminary and subject to change.
 † Units in nanoseconds (ns).

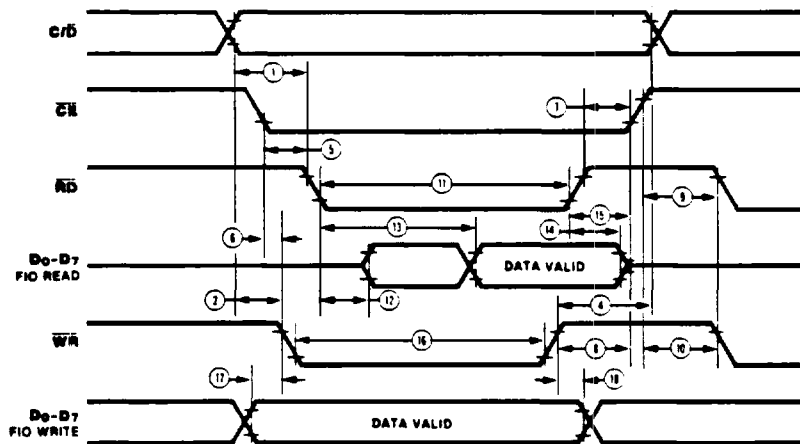

Figure 41. Non-Z-BUS CPU Interface Timing

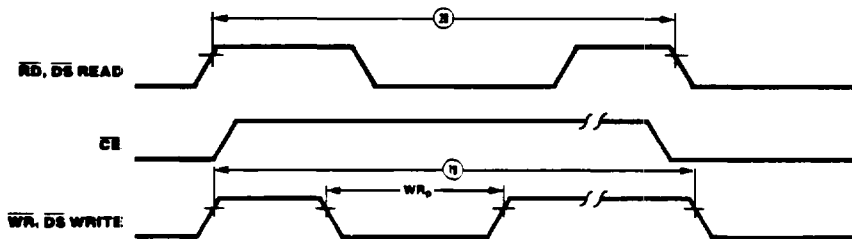

Figure 42. Z-BUS/Non-Z-BUS Recovery Time

AC Characteristics

No.	Symbol	Parameter	4 MHz		6 MHz		Notes†*
			Min	Max	Min	Max	
20	TdIEI(IEO)	IEI to IEO Delay		150		100	4
21	TdI(IEO)	$\overline{\text{INTACK}} \downarrow$ to IEO \downarrow Delay		350		250	4
22	TsIEI(RDA)	IEI Setup Time to $\overline{\text{RD}}$ (Acknowledge)	100		70		4
23	TdRD(DR)	$\overline{\text{RD}} \downarrow$ to Vector Valid Delay		250		180	
24	TwRD1(IA)	Read Low Width (Interrupt Acknowledge)	390		250		
25	ThIA(RD)	$\overline{\text{INTACK}} \uparrow$ to $\overline{\text{RD}} \uparrow$ Hold Time	30		20		
26	ThIEI(RD)	IEI Hold Time to $\overline{\text{RD}} \uparrow$	20		10		
27	TdRD(INT)	$\overline{\text{RD}} \downarrow$ to $\overline{\text{INT}} \uparrow$ Delay		900		800	
28	TdDCST	Interrupt Daisy Chain Settle Time	350		250		4

NOTES:

4. The parameter for the devices in any particular daisy chain must meet the following constraint: The delay from $\overline{\text{INTACK}} \downarrow$ to $\overline{\text{RD}} \downarrow$ must be greater than the sum of TdI(IEO) for the highest priority peripheral, TsIEI(RD)

for the lowest priority peripheral, and TdIEI(IEO) for each peripheral separating them in the chain.

† Units in nanoseconds (ns).

* Timings are preliminary and subject to change

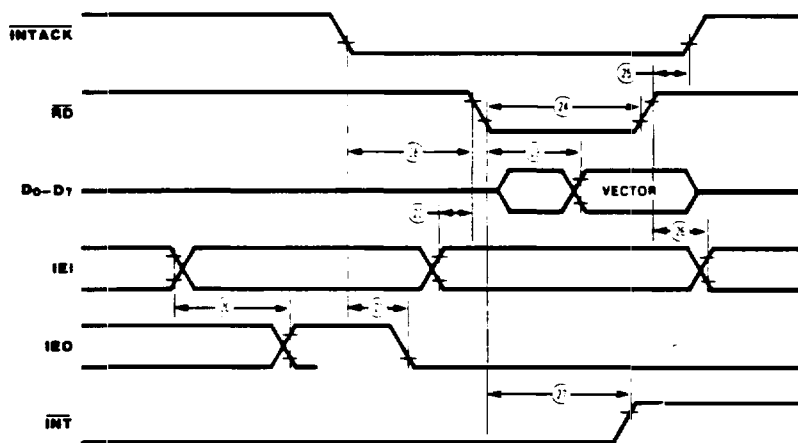

Figure 43. Non-Z-BUS Interrupt Acknowledge Timing

AC Characteristics

No.	Symbol	Parameter	4 MHz		6 MHz		Notes*†
			Min	Max	Min	Max	
29	TdMW(INT)	Message Write to $\overline{\text{INT}}$ Delay					5,6
30	TdDC(INT)	Data Direction Change to $\overline{\text{INT}}$ Delay					5,7
31	TdPMW(INT)	Pattern Match (Write Case) to $\overline{\text{INT}}$ Delay					5
32	TdPMR(INT)	Pattern Match (Read Case) to $\overline{\text{INT}}$ Delay					5
33	TdSC(INT)	Status Compare to $\overline{\text{INT}}$ Delay					5,7
34	TdER(INT)	Error to $\overline{\text{INT}}$ Delay					5,7
35	TdEM(INT)	Empty to $\overline{\text{INT}}$ Delay					5,7
36	TdFL(INT)	Full to $\overline{\text{INT}}$ Delay					5,7
37	TdSO(INT)	State 0 to $\overline{\text{INT}}$ Delay					

NOTES

5. Delay number is valid for State 0 only.

6. Write is from other side of FIO.

7. Write can be from either side, depending on programming of FIO.

* Timings are preliminary and subject to change.

† Units in nanoseconds (ns).

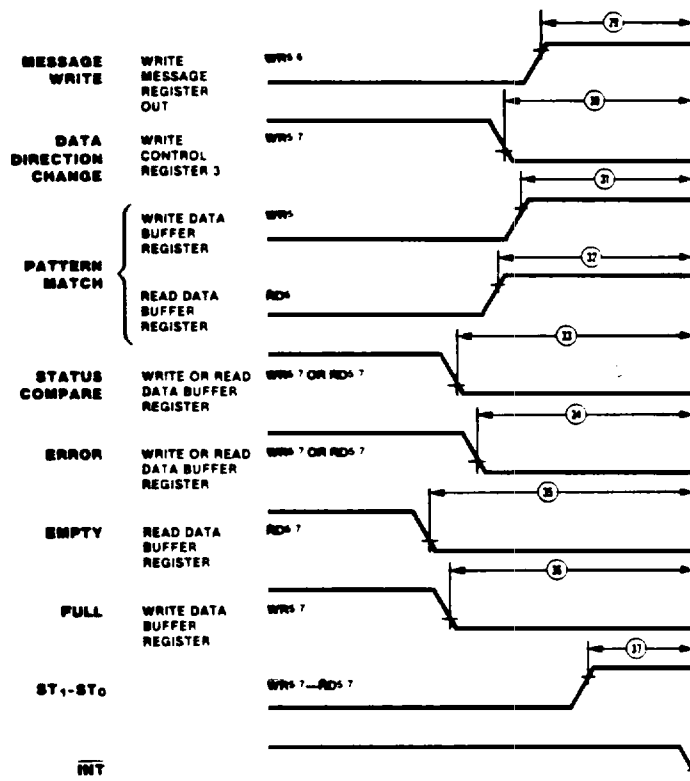

Figure 44. FIO Non-Z-BUS Interrupt Timing

AC Characteristics

No.	Symbol	Parameter	4 MHz		6 MHz		Notes*†
			Min	Max	Min	Max	
1	TdCE(WT)	$\overline{CE} \downarrow$ to \overline{WAIT} Active		200		170	
2	TdRD1(WT)	$\overline{RD} \downarrow$ or $\overline{WR} \downarrow$ to \overline{WAIT} Inactive		1000		1000	
3	TdACK(WT)	$\overline{ACKIN} \downarrow$ to \overline{WAIT} Inactive		1000		1000	1
4	TdRD(REQ)	$\overline{RD} \downarrow$ or $\overline{WR} \downarrow$ to \overline{REQ} Inactive		350		300	
5	TdRD1(REQ)	$\overline{RD} \downarrow$ or $\overline{WR} \downarrow$ to \overline{REQ} Active		1000		1000	
6	TdACK(REQ)	$\overline{ACKIN} \downarrow$ to \overline{REQ} Active		1000		1000	
7	TdDAC(RD)	$\overline{DACK} \downarrow$ to $\overline{RD} \downarrow$ or $\overline{WR} \downarrow$	100		80		
8	TSU(WR)	Data Setup Time to \overline{WR}	200				
9	Th(WR)	Data Hold Time to \overline{WR}	30		20		
10	TdDMA	$\overline{RD} \downarrow$ to Valid Data		150		100	2
11	TdDMA(DRH)	$\overline{RD} \downarrow$ to Data Not Valid	0		0		2
12	TdDMA(DRZ)	$\overline{RD} \downarrow$ to Data Bus Float		70		45	2

NOTES:

1. The delay is from $\overline{DAV} \downarrow$ for 3-Wire Input Handshake. The delay is from $\overline{DAC} \downarrow$ for 3-Wire Output Handshake.
2. Only when \overline{DACK} is active.

- * Timings are preliminary and subject to change.
 † Units in nanoseconds (ns).

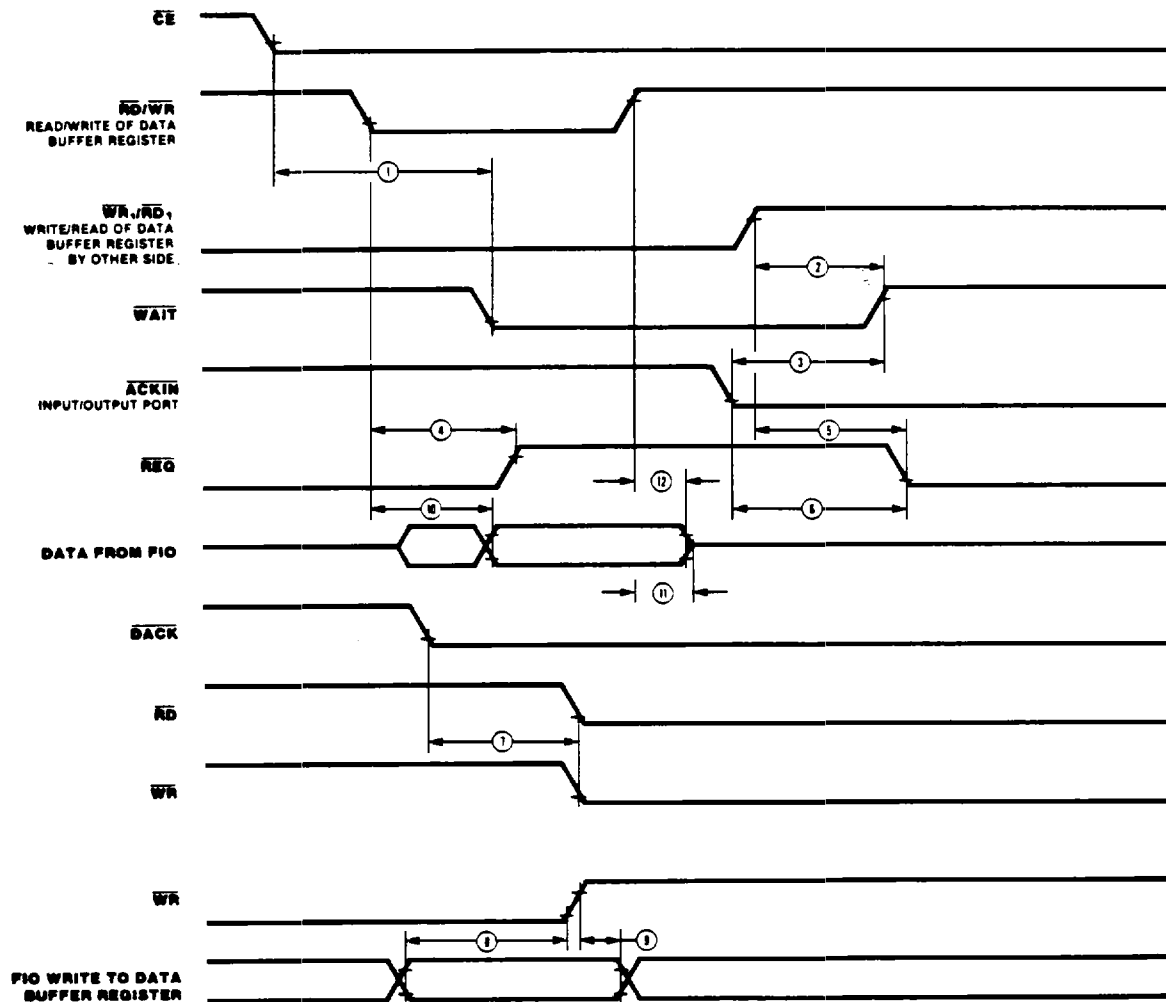

Figure 45. Non-Z-BUS Request/Wait Timing

AC Characteristics

No.	Symbol	Parameter	4 MHz		6 MHz		Notes*†
			Min	Max	Min	Max	
1	TdWR(RD)	Delay from $\overline{WR} \uparrow$ to $\overline{RD} \downarrow$	100		70		
2	TdRD(WR)	Delay from $\overline{RD} \uparrow$ to $\overline{WR} \downarrow$	100		70		
3	TwRD + WR	Width of \overline{RD} and \overline{WR} , both Low for Reset	500		350		

NOTES:

* Timings are preliminary and subject to change.

† Units in nanoseconds (ns).

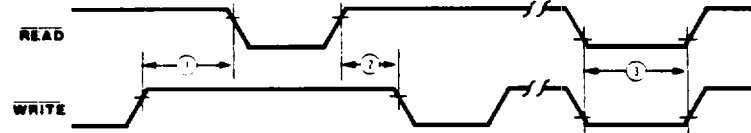

Figure 46. Non-Z-BUS Reset Timing

AC Characteristics

No.	Symbol	Parameter	4 MHz		6 MHz		Notes*†
			Min	Max	Min	Max	
1	TwCLR	Width of Clear to Reset FIFO	700		700		
2	TdOE(DO)	$\overline{OE} \uparrow$ to Data Bus Driven		210		210	
3	TdOE(DRZ)	$\overline{OE} \uparrow$ to Data Bus Float		150		150	
4	TdCLR(ACK)	$\overline{CLEAR} \uparrow$ to $\overline{ACKIN} \downarrow$	800		800		

NOTES:

* Timings are preliminary and subject to change.

† Units in nanoseconds (ns).

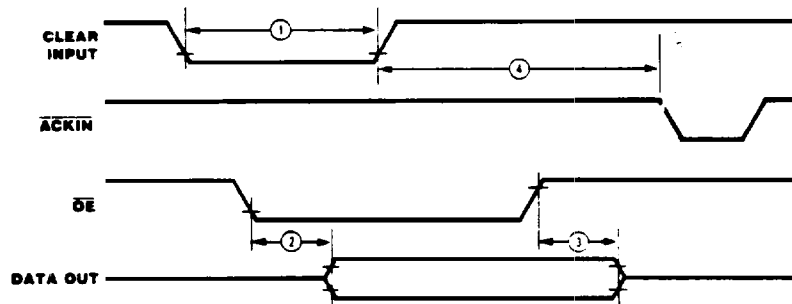

Figure 47. Port 2 Side Operation

AC Characteristics

No.	Symbol	Parameter	4 MHz		6 MHz		Notes*†
			Min	Max	Min	Max	
1	TsDI(ACK)	Data Input to $\overline{\text{ACKIN}}$ ↓ to Setup Time	50		50		
2	TdACKf(RFD)	$\overline{\text{ACKIN}}$ ↓ to RFD ↓ Delay	0	500	0	500	
3	TdRFDr(ACK)	RFD ↑ to $\overline{\text{ACKIN}}$ ↓ Delay	0		0		
4	TsDO(DAV)	Data Out to $\overline{\text{DAV}}$ ↓ Setup Time	50		25		
5	TdDAVf(ACK)	$\overline{\text{DAV}}$ ↓ to $\overline{\text{ACKIN}}$ ↓ Delay	0		0		
6	ThDO(ACK)	Data Out to $\overline{\text{ACKIN}}$ Hold Time	50		50		
7	TdACK(DAV)	$\overline{\text{ACKIN}}$ ↓ to $\overline{\text{DAV}}$ ↓ Delay	0	500	0	500	
8	ThDI(RFD)	Data Input to RFD ↓ Hold Time	0		0		
9	TdRFDf(ACK)	RFD ↓ to $\overline{\text{ACKIN}}$ ↓ Delay	0		0		
10	TdACKr(RFD)	$\overline{\text{ACKIN}}$ ↓ ($\overline{\text{DAV}}$ ↓) to RFD ↓ Delay—Interlocked and 3-Wire Handshake	0	400	0	400	
11	TdDAVr(ACK)	$\overline{\text{DAV}}$ ↓ to $\overline{\text{ACKIN}}$ ↓ (RFD ↓)	0		0		
12	TdACKr(DAV)	$\overline{\text{ACKIN}}$ ↓ to $\overline{\text{DAV}}$ ↓	0	800	0	800	
13	TdACKf(Empty)	$\overline{\text{ACKIN}}$ ↓ to Empty	0		0		
14	TdACKf(Full)	$\overline{\text{ACKIN}}$ ↓ to Full	0		0		
15	TcACK	$\overline{\text{ACKIN}}$ Cycle Time	1		1		1

NOTES:

* Timings are preliminary and subject to change.

† Units in nanoseconds (ns), except as noted.

1. Units in microseconds.

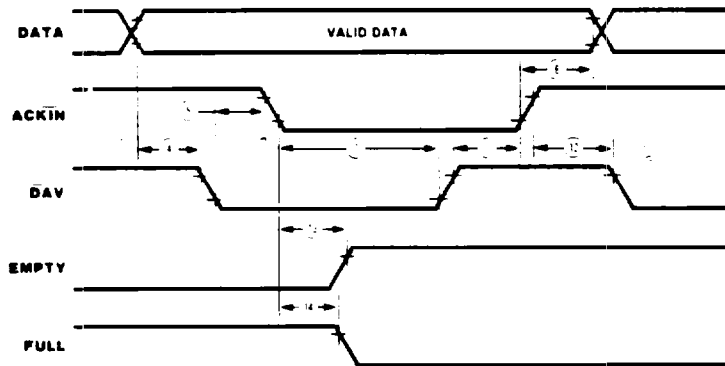

Figure 48. 2-Wire Handshake (Port 2 Side Only) Output

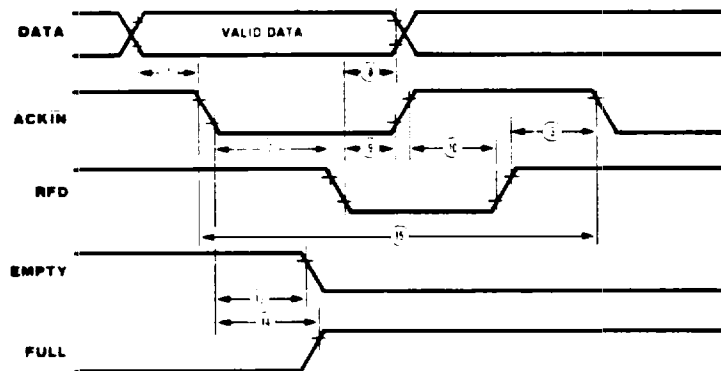

Figure 49. 2-Wire Handshake (Port 2 Side Only) Input

AC Characteristics

No.	Symbol	Parameter	4 MHz		6 MHz		Notes*†
			Min	Max	Min	Max	
1	TsDI(DAV)	Data Input to $\overline{\text{DAV}}$ ↓ Setup Time	50		50		
2	TdDAVI(RFD)	$\overline{\text{DAV}}$ ↓ to RFD ↓ Delay	0	500	0	500	
3	TdDAVI(DAC)	$\overline{\text{DAV}}$ ↓ to DAC ↓ Delay	0	500	0	500	
4	ThDI(DAC)	Data In to DAC ↑ Hold Time	0		0		
5	TdDACIr(DAV)	DAC ↓ to $\overline{\text{DAV}}$ ↑ Delay	0		0		
6	TdDAVIr(DAC)	$\overline{\text{DAV}}$ ↑ to DAC ↓ Delay	0	500	0	500	
7	TdDAVIr(RFD)	$\overline{\text{DAV}}$ ↑ to RFD ↓ Delay	0	500	0	500	
8	TdRFDI(DAV)	RFD ↓ to $\overline{\text{DAV}}$ ↓ Delay	0		0		
9	TsDO(DAC)	Data Out to $\overline{\text{DAV}}$ ↓					
10	TdDAVOI(RFD)	$\overline{\text{DAV}}$ ↓ to RFD ↓ Delay	0		0		
11	TdDAVOI(DAC)	$\overline{\text{DAV}}$ ↓ to DAC ↓ Delay	0		0		
12	ThDO(DAC)	Data Out to DAC ↑ Hold Time					
13	TdDACOr(DAV)	DAC ↓ to $\overline{\text{DAV}}$ ↑ Delay		400		400	
14	TdDAVOr(DAC)	$\overline{\text{DAV}}$ ↑ to DAC ↓ Delay	0		0		
15	TdDAVOr(RFD)	$\overline{\text{DAV}}$ ↑ to RFD ↓ Delay	0		0		
16	TdRFDO(DAV)	RFD ↓ to $\overline{\text{DAV}}$ ↓ Delay	0	800	0	800	

NOTES:

* Timings are preliminary and subject to change.

† Units in nanoseconds (ns).

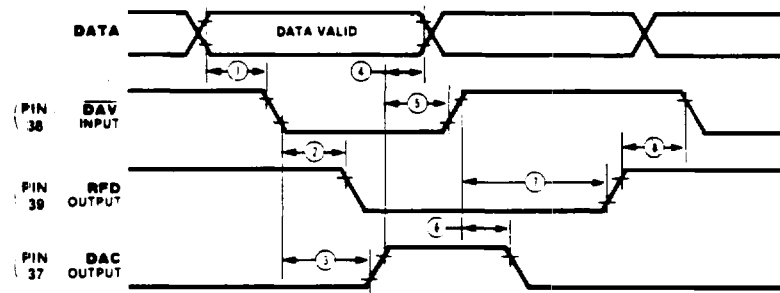

Figure 50. 3-Wire Handshake Input

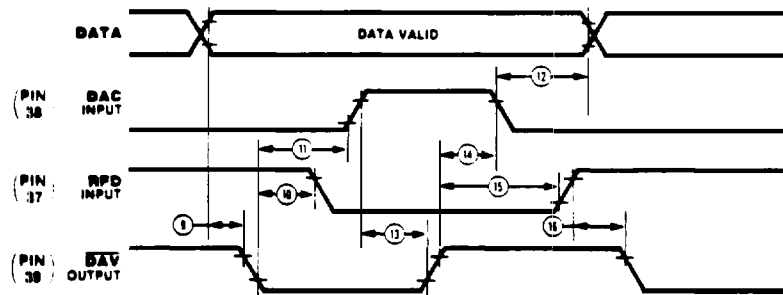

Figure 51. 3-Wire Handshake Output

MIL-STD-883 MILITARY PROCESSED PRODUCT

- Mil-Std-883 establishes uniform methods and procedures for testing microelectronic devices to insure the electrical, mechanical, and environmental integrity and reliability that is required for military applications.
- Mil-Std-883 Class B is the industry standard product assurance level for military ground and aircraft application.
- The total reliability of a system depends upon tests that are designed to stress specific quality and reliability concerns that affect microelectronic products.
- The following tables detail the 100% screening and electrical tests, sample electrical tests, and Qualification/Quality Conformance testing required.

Zilog Military Product Flow

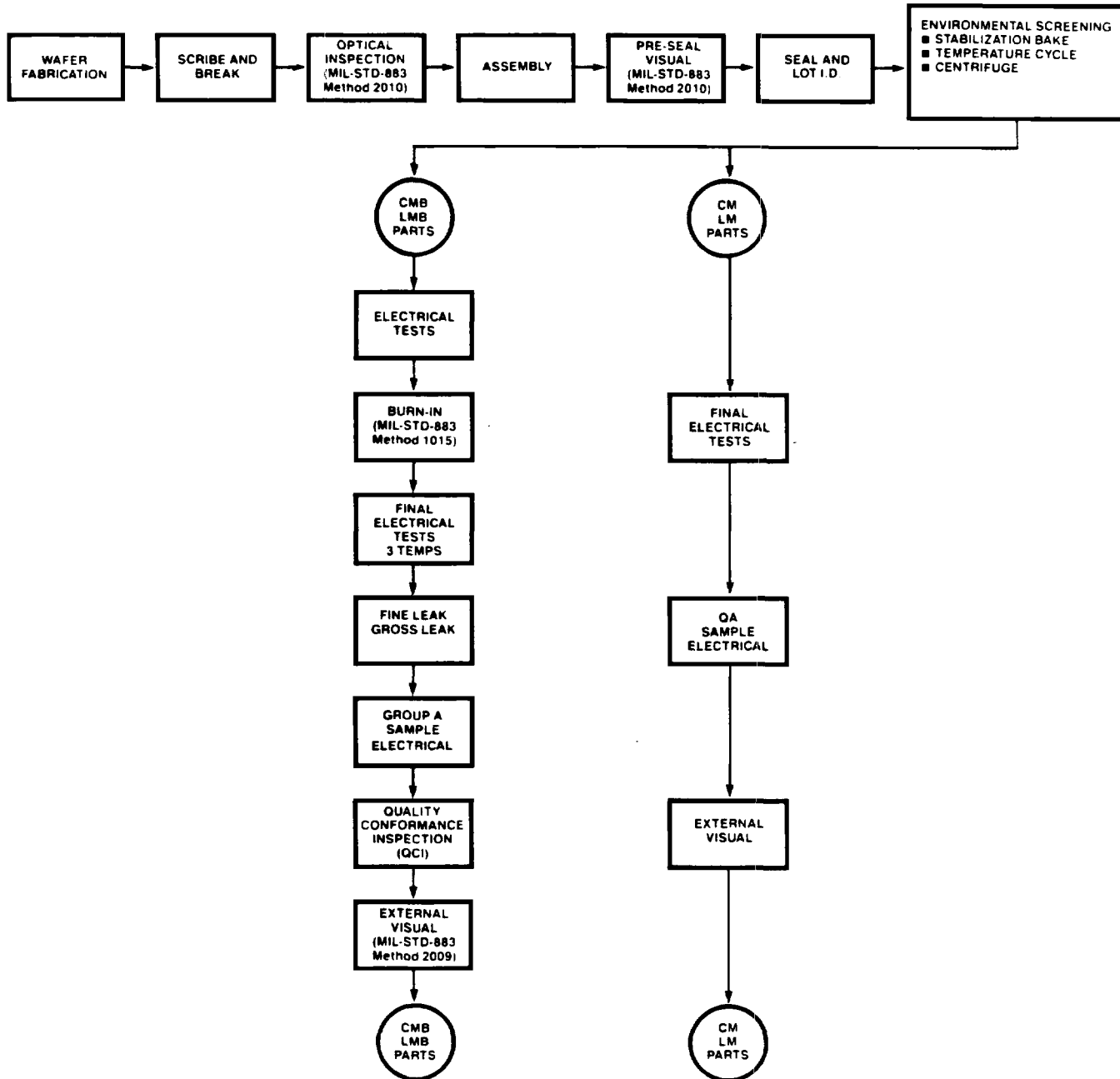

Table I
MIL-STD-883 Class B Screening Requirements
Method 5004

Test	Mil-Std-883 Method	Test Condition	Requirement	
Internal Visual	2010	Condition B	100%	
Stabilization Bake	1008	Condition C	100%	
Temperature Cycle	1010	Condition C	100%	
Constant Acceleration (Centrifuge)	2001	Condition E or D ^(Note 1) , Y ₁ Axis Only	100%	
Initial Electrical Tests		Zilog Military Electrical Specification Static/DC T _C = +25°C	100%	
Burn-In	1015	Condition C or D (Note 2), 160 hours T _A = +125°C	100%	
Interim Electrical Tests		Zilog Military Electrical Specification Static/DC T _C = +25°C	100%	
PDA Calculation		PDA = 5%	100%	
Final Electrical Tests		Zilog Military Electrical Specification Static/DC T _C = +125°C, -55°C Functional, Switching/AC T _C = +25°C	100%	
Fine Leak	1014	Condition B	100%	
Gross Leak	1014	Condition C	100%	
Quality Conformance Inspection (QCI)				
Group A	Each Inspection Lot	5005	(See Table II)	Sample
Group B	Every Week	5005	(See Table III)	Sample
Group C	Periodically (Note 3)	5005	(See Table IV)	Sample
Group D	Periodically (Note 3)	5005	(See Table V)	Sample
External Visual	2009		100%	
QA—Ship			100%	

NOTES:

1. Applies to larger packages which have an inner seal or cavity perimeter of two inches or more in total length or have a package mass of ≥ 5 grams.
2. Fully compliant to Mil-Std-883 Revision C requirements.
3. Performed periodically as required by Mil-Std-883, paragraph 1.2.1 b(17).

Table II Group A
Sample Electrical Tests
MIL-STD-883 Method 5005

Subgroup	Tests	Temperature (T_c)	LTPD Max Accept = 2
Subgroup 1	Static/DC	+ 25 °C	2
Subgroup 2	Static/DC	+ 125 °C	3
Subgroup 3	Static/DC	- 55 °C	5
Subgroup 7	Functional	+ 25 °C	2
Subgroup 8	Functional	- 55 °C and + 125 °C	5
Subgroup 9	Switching/AC	+ 25 °C	2
Subgroup 10	Switching/AC	+ 125 °C	3
Subgroup 11	Switching/AC	- 55 °C	5

NOTES

- The specific parameters to be included for tests in each subgroup shall be as specified in the applicable detail electrical specification. Where no parameters have been identified in a particular subgroup or test within a subgroup, no Group A testing is required for that subgroup or test.
- A single sample may be used for all subgroup testing. Where required size exceeds the lot size, 100% inspection shall be allowed.
- Group A testing by subgroup or within subgroups may be performed in any sequence unless otherwise specified.

Table III Group B
Sample Test Performed Every Week to
Test Construction and Insure Integrity of Assembly Process.
MIL-STD-883 Method 5005

Subgroup	Mil-Std-883 Method	Test Condition	Quantity or LTPD/Max Accept
Subgroup 1 Physical Dimensions	2016		2/0
Subgroup 2 Resistance to Solvents	2015		4/0
Subgroup 3 Solderability	2003	Solder Temperature + 245°C ± 5°C	15 ^(Note 1)
Subgroup 4 Internal Visual and Mechanical	2014		1/0
Subgroup 5 Bond Strength	2011	C	15 ^(Note 2)
Subgroup 6 ^(Note 3) Internal Water Vapor Content	1018	1000 ppm. maximum at + 100°C	3/0 or 5/1
Subgroup 7 ^(Note 4) Seal 7a) Fine Leak 7b) Gross Leak	1014	7a) B 7b) C	5
Subgroup 8 ^(Note 5) Electrostatic Discharge Sensitivity	3015	Zilog Military Electrical Specification Static/DC T _C = + 25°C A = 20-2000V B = >2000V Zilog Military Electrical Specification Static/DC T _C = + 25°C	15/0

NOTES

1. Number of leads inspected selected from a minimum of 3 devices.
2. Number of bond pulls selected from a minimum of 4 devices
3. Test applicable only if the package contains a dessicant
4. Test not required if either 100% or sample seal test is performed between final electrical tests and external visual during Class B screening
5. Test required for initial qualification and product redesign.

Table IV Group C
Sample Test Performed Periodically to Verify Integrity of the Die.
MIL-STD-883 Method 5005

Subgroup	Mil-Std-883 Method	Test Condition	Quantity or LTPD/Max Accept
Subgroup 1			
Steady State Operating Life	1005	Condition C or D (Note 1), 1000 hours at +125 C +125°C	
End Point Electrical Tests		Zilog Military Electrical Specification T _C = +25°C, +125°C, -55°C	
Subgroup 2			
Temperature Cycle	1010	Condition C	
Constant Acceleration (Centrifuge)	2001	Condition E or D ^(Note 2) , Y ₁ Axis Only	
Seal	1014		15
2a) Fine Leak		2a) Condition B	
2b) Gross Leak		2b) Condition C	
Visual Examination	1010 or 1011		
End Point Electrical Tests		Zilog Military Electrical Specification T _C = +25°C, +125°C, -55°C	

NOTE:

1. Fully compliant to Mil-Std-883 Revision C requirements.
2. Applies to larger packages which have an inner seal or cavity perimeter of two inches or more in total length or have a package mass of ≥ 5 grams.

Table V Group D
Sample Test Performed Periodically to Insure Integrity of the Package.
MIL-STD-883 Method 5005

Subgroup	Mil-Std-883 Method	Test Condition	Quantity or LTPD/Max Accept
Subgroup 1 Physical Dimensions	2016		15
Subgroup 2 Lead Integrity	2004	Condition B ₂ or D ^(Note 1)	15
Subgroup 3 Thermal Shock	1011	Condition B minimum, 15 cycles minimum	
Temperature Cycling	1010	Condition C, 100 cycles minimum	15
Moisture Resistance	1004		
Seal	1014		
3a) Fine Leak		3a) Condition B	
3b) Gross Leak		3b) Condition C	
Visual Examination	1004 or 1010		
End Point Electrical Tests		Zilog Military Electrical Specification T _C = +25 °C, +125 °C, -55 °C	
Subgroup 4 Mechanical Shock	2002	Condition B minimum	
Vibration Variable Frequency	2007	Condition A minimum	
Constant Acceleration (Centrifuge)	2001	Condition E or D ^(Note 2) , Y ₁ Axis Only	15
Seal	1014		
4a) Fine Leak		4a) Condition B	
4b) Gross Leak		4b) Condition C	
Visual Examination	1010 or 1011		
End Point Electrical Tests		Zilog Military Electrical Specification T _C = +25 °C, +125 °C, -55 °C	
Subgroup 5 Salt Atmosphere	1009	Condition A minimum	
Seal	1014		15
5a) Fine Leak		5a) Condition B	
5b) Gross Leak		5b) Condition C	
Visual Examination	1009		
Subgroup 6 Internal Water Vapor Content	1018	5,000 ppm. maximum water content at +100 °C	3/0 or 5/1
Subgroup 7 ^(Note 3) Adhesion of Lead Finish	2025		15 ^(Note 4)
Subgroup 8 ^(Note 5) Lid Torque	2024		5/0

NOTES:

1. Lead Integrity Condition D for leadless chip carriers.
2. Applies to larger packages which have an inner seal or cavity perimeter of two inches or more in total length or have a package mass of ≥5 grams.
3. Not applicable to leadless chip carriers.
4. LTPD based on number of leads
5. Not applicable for solder seal packages

PACKAGING INFORMATION

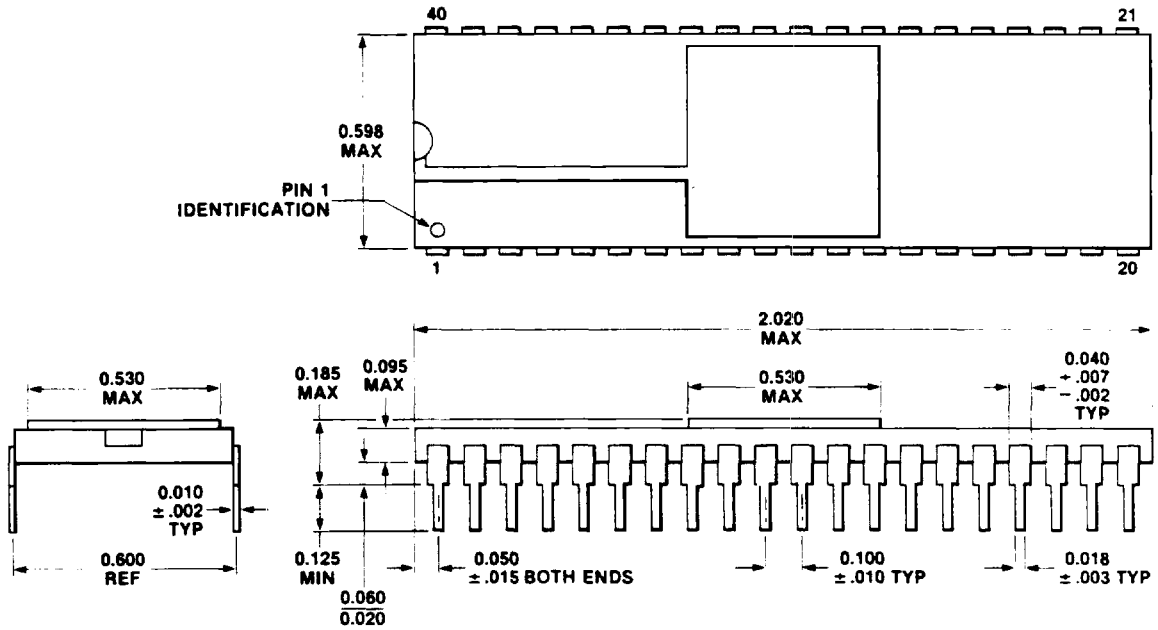

40-Pin Ceramic Dual In-line Package (DIP)

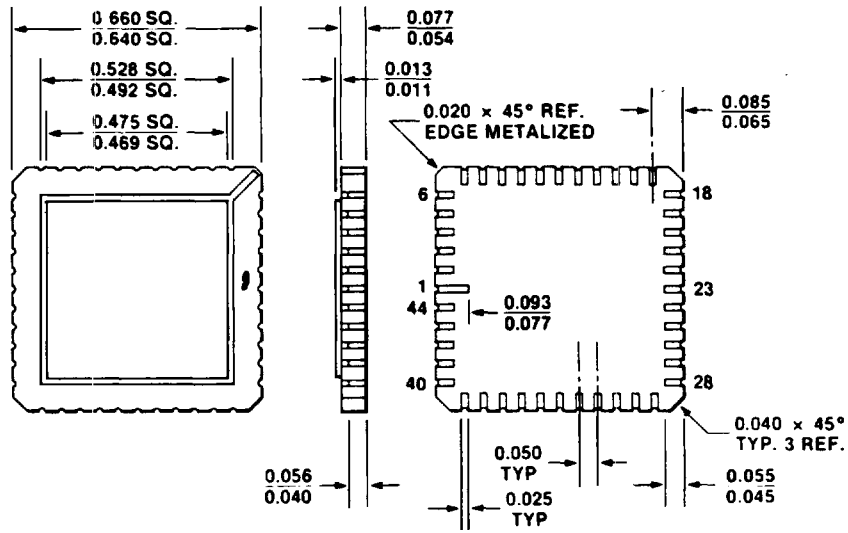

44-Pin Ceramic Leadless Chip Carrier (LCC)

NOTE: Package dimensions are given in inches. To convert to millimeters, multiply by 25.4

ORDERING INFORMATION

Z8038 Z-FIO, 4 MHz
40-pin DIP
Z0803804CMB

Z8038 Z-FIO, 6 MHz
40-pin DIP 44-pin LCC
Z0803806CME Z0803806LME
Z0803806CMB Z0803806LMB

Z8538 FIO, 6 MHz
40-pin DIP 44-pin LCC
Z0853806CME Z0853806LME
Z0853806CMB Z0853806LMB

Codes

PACKAGE

D = Cerdip
P = Plastic
V = Plastic Chip Carrier

Longer Lead Time

C = Ceramic
F = Plastic Quad Flat Pack
G = Ceramic PGA (Pin Grid Array)
L = Ceramic LCC
Q = Ceramic Quad-in-Line
R = Protopack
T = Low Profile Protopack

TEMPERATURE

S = 0°C to +70°C

Longer Lead Time
E = -40°C to +85°C
M = -55°C to +125°C

ENVIRONMENTAL

C = Plastic Standard
E = Hermetic Standard

Longer Lead Time
A = Hermetic Stressed
B = 833 Class B Military
D = Plastic Stressed
J = JAN 38510 Military

Example:

Z803804CMB is a 8038, 4 MHz, Ceramic, -55°C to +125°C, 833 Class B Flow.

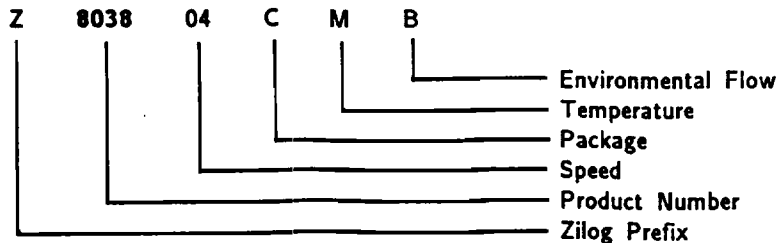

**ZILOG DOMESTIC SALES OFFICES
AND TECHNICAL CENTERS****CALIFORNIA**

Agoura.....818-707-2160
Campbell.....408-370-8016
Costa Mesa.....714-261-1281

COLORADO

Boulder.....303-494-2905

FLORIDA

Largo.....813-585-2533

GEORGIA

Atlanta.....404-451-8425

ILLINOIS

Schaumburg.....312-885-8080

MASSACHUSETTS

Burlington.....617-273-4222

MINNESOTA

Edina.....612-831-7611

NEW JERSEY

Hasbrouck Heights.....201-288-3737
Mt. Laurel.....609-778-8070

OHIO

Seven Hills.....216-447-1480

TEXAS

Richardson.....214-231-9090

INTERNATIONAL SALES OFFICES**CANADA**

Toronto.....416-673-0634

GERMANY

Munich.....49-89-612-6046

JAPAN

Tokyo.....81-3-587-0528

HONG KONG

Kowloon.....852-3-723-8979

R.O.C.

Taiwan.....886-2-731-2420

UNITED KINGDOM

Maidenhead.....44-628-39200

©1987 by Zilog, Inc. All rights reserved. No part of this publication may be reproduced, stored in a retrieval system, or transmitted, in any form or by any means, electronic, mechanical, photocopying, recording, or otherwise, without the prior written permission of Zilog.

The information contained herein is subject to change without notice. Zilog assumes no responsibility for the use of any circuitry embodied in a Zilog product. No other circuit patent licenses are implied.

All specifications (parameters) are subject to change without notice. The applicable Zilog test documentation will specify which parameters are tested.