

Product Preview

1.8 V PLL 1:10 Differential SDRAM Clock Driver

Recommended Applications

- DDR II Memory Modules
- Zero Delay Board fan-out

Features

- 1.8-V Phase Lock Loop Clock Driver for (DDR II) Applications
- Spread Spectrum Clock Compatible
- Operating Frequency: 100 MHz to 340 MHz
- 1 to 10 differential clock distribution (SSTL_18)
- 52-Ball VF-BGA (FP-MAPBGA 0.65-mm pitch) and 40-Pin MLF(QFN)
- External Feedback Pins (FBIN, $\overline{\text{FBIN}}$) are used to synchronize the Outputs to the Input Clocks
- Single-Ended Input and Single-Ended Output Modes
- Meets or Exceeds JESD82-8 PLL Standard for PC2-3200/4300
- Auto Power Down detect logic

Switching Characteristics

- Cycle to Cycle Jitter (>165 Mhz): 40ps max.
- Output to Output Skew: 40 ps max.

Functional Description

The MPC96877 is a high-performance, low-jitter, low-skew, zero-delay buffer that distributes a differential clock input pair (CK, $\overline{\text{CK}}$) to ten differential pairs of clock outputs (Y_n , $\overline{\text{Y}}_n$) and to one differential pair of feedback clock outputs ($\overline{\text{FBOU}}_T$, $\overline{\text{FBOU}}_T$). The clock outputs are controlled by the input clocks (CK, $\overline{\text{CK}}$), the feedback clocks (FBIN, $\overline{\text{FBIN}}$), the LVC MOS control pins (OE, OS), and the analog power input (AV_{DD}). When OE is low, the clock outputs, except $\overline{\text{FBOU}}_T/\overline{\text{FBOU}}_T$, are disabled while the internal PLL continues to maintain its locked-in frequency. OS (output select) is a program pin that must be tied to GND or V_{DD} . When OS is high, OE functions as previously described. When OS and OE are both low, OE has no effect on $\text{Y}_7/\overline{\text{Y}}_7$, they are free running. When AV_{DD} is grounded, the PLL is turned off and bypassed for test purposes. When both clock inputs (CK, $\overline{\text{CK}}$) are logic low, the device enters in a low power mode. An input logic detection circuit on the differential inputs, independent from input buffers, detects the logic low level and performs in a low power state where all outputs, the feedback, and the PLL are off. When the clock inputs transition from being logic low to being differential signals, the PLL turns back on, the inputs and the outputs are enabled, and the PLL obtains phase lock between the feedback clock pair (FBIN, $\overline{\text{FBIN}}$) and the clock input pair (CK, $\overline{\text{CK}}$) within the specified stabilization time.

The MPC96877 is able to track spread spectrum clocking (SSC) for reduced EMI. This device operates from 0°C to 70°C.

MPC96877

**DDR II MEMORY
CLOCK / ZERO DELAY BUFFER**



SCALE 2:1

VK SUFFIX
52-BALL FP-MAPBGA PACKAGE
CASE 1544-01

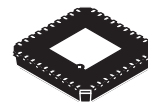

SCALE 2:1

EP SUFFIX
40-PIN MLF/QFN PACKAGE
CASE 1545-01

AVAILABLE ORDERING OPTIONS

T_A	52-Ball BGA	40-Pin QFN
0°C to 70°C	MPC96877VK (Pb-Free)	MPC96877EP (Pb-Free)

MPC96877

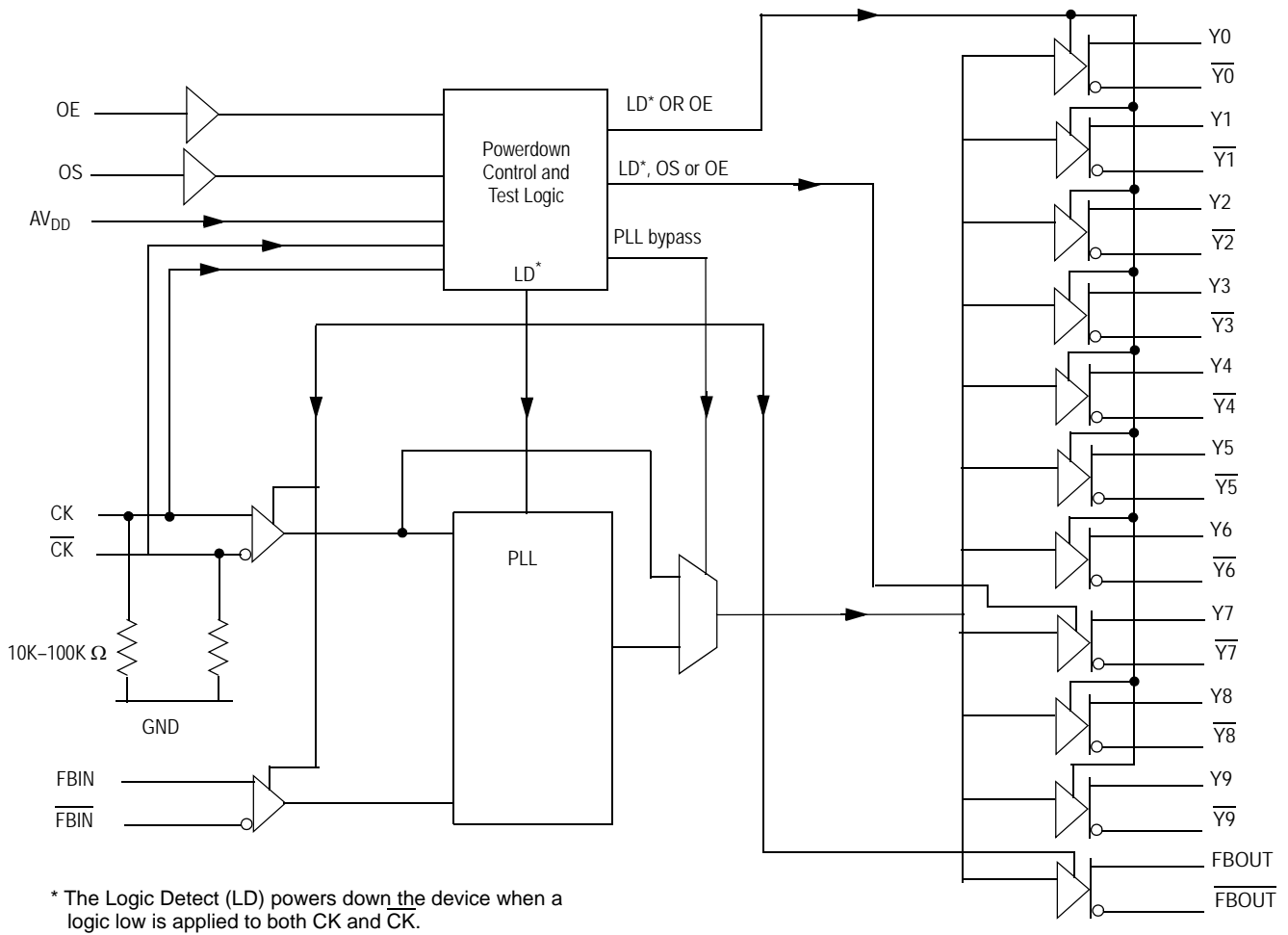
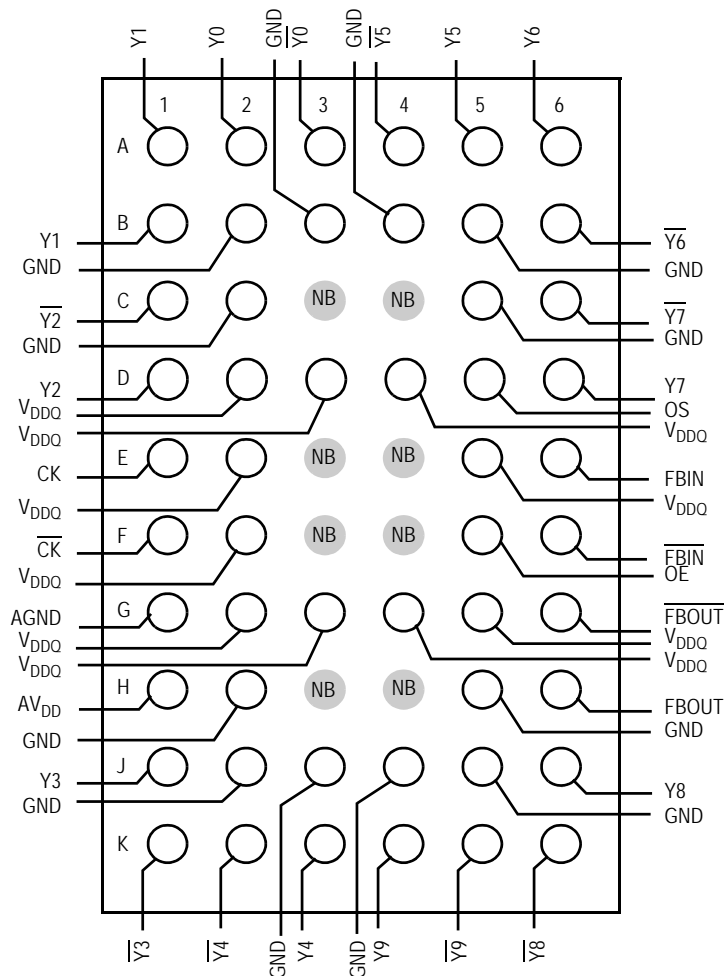
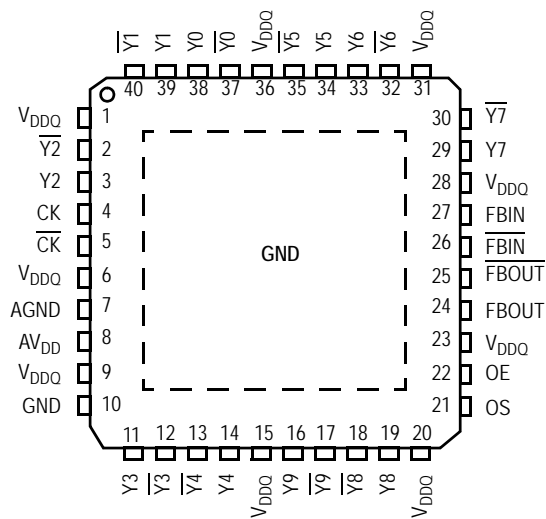

Figure 1. MPC96877 Logic Diagram

VF-MAPBGA (VK) PACKAGE



**EP PACKAGE
(TOP VIEW)**



40-Pin TE-QFN(6.0 x 6.0 mm Body Size,
0.5 mm Pitch, M0#220, Variation VJJD-2,
E2 = D2 = 2.9 mm ±0.15 mm) Package Pinouts

MPC96877

Table 1. Pin Configuration

Pin	BGA	MLF	I/O	Function
AGND	G1	7		Analog ground
AV _{DD}	H1	8		Analog power
CK	E1	4	Input	Clock input with a (10k to 100k) pulldown resistor
$\overline{\text{CK}}$	E6	5	Input	Complimentary clock input with a (10 k to 100k) pulldown resistor
FBIN	F6	27	Input	Feedback clock input
$\overline{\text{FBIN}}$		26	Input	Complimentary Feedback clock input
FBOU _T	H6	24	Output	Feedback clock output
$\overline{\text{FBOU}}\overline{\text{T}}$	G6	25	Output	Complimentary feeback clock output
OE	F5	22	Input	Output Enable (asynchronous)
OS	D5	21	Input	Output Select (tied to GND or V _{DD})
GND	B2, B3, B4, B5, C2,C5,H2,H5, J2, J3, J4, J5	10		Ground
V _{DDQ}	D2, D3, D4, E2, E5, F2, G2, G3, G4, G5	1, 6, 9, 15, 20, 23, 28, 31, 36		Logic and output power
Y[0:9]	A2, A1, D1, J1, K3, A5, A6, D6, J6, K4	38, 39, 3, 11, 14, 34, 33, 29, 19, 16	Output	Clock outputs
Y[0:9]	A3, B1, C1, K1, K2, A4, B6, C6, K6, K5	37, 40, 2, 12, 13, 35, 32, 30, 18, 17	Output	Complimentary clock outputs

Table 2. Function Table

Inputs					Outputs				PLL
AV _{DD}	OE	OS	CK	$\overline{\text{CK}}$	Y	Y	FBOU _T	$\overline{\text{FBOU}}\overline{\text{T}}$	
GND	H	X	L	H	L	H	L	H	Bypassed / OFF
GND	H	X	H	L	H	L	H	L	Bypassed / OFF
GND	L	H	L	H	L _Z	L _Z	L	H	Bypassed / OFF
GND	L	L	H	L	L _Z ¹ Y7 Active	$\overline{\text{L}}\text{Z}^1$ $\overline{\text{Y}}7$ Active	H	L	Bypassed / OFF
1.8 V Nominal	L	H	L	H	L _Z ¹	L _Z ¹	L	H	ON
1.8 V Nominal	L	L	H	L	L _Z ¹ Y7 Active	$\overline{\text{L}}\text{Z}^1$ $\overline{\text{Y}}7$ Active	H	L	ON
1.8 V Nominal	H	X	L	H	L	H	L	H	ON
1.8 V Nominal	H	X	H	L	H	L	H	L	ON
1.8 V Nominal	X	X	L	L	L _Z ¹	L _Z ¹	L _Z ¹	L _Z ¹	OFF
X	X	X	H	H	RESERVED				

1. L_Z means the outputs are disabled to a low state meeting the I_{ODL} limit in Table 5.

Table 3. Absolute Maximum Ratings over Free-Air Operating Range¹

Parameter	Value
Supply voltage range, V_{DDQ} or AV_{DD}	-0.5 V to 2.5 V
Input voltage range, $V_I^{2,3}$	-0.5 V to $V_{DDQ} + 0.5$ V
Output voltage range, $V_O^{1,2}$	-0.5 V to $V_{DDQ} + 0.5$ V
Input clamp current, I_{IK} ($V_I < 0$ or $V_I > V_{DDQ}$)	±50 mA
Output clamp voltage, I_{OK} ($V_O < 0$ or $V_O > V_{DDQ}$)	±50 mA
Continuous output current, I_O ($V_O = 0$ to V_{DDQ})	±50 mA
Continuous current through each V_{DDQ} or GND	±100 mA
Storage temperature range, T_{STG}	-65°C to 150°C

- Stresses beyond those listed under “absolute maximum ratings” may cause permanent damage to the device. These are stress ratings only, and functional operation of the device at these or any other conditions beyond those indicated under “recommended operating conditions” is not implied. Exposure to absolute-maximum-rated conditions for extended periods may affect device reliability.
- The input and output voltage ratings may be exceeded if the input and output clamp-current ratings are observed.
- This value is limited to 2.5 V maximum.

Table 4. Recommended Operating Conditions

Rating	Parameter	Affected Pins	Min	Nom	Max	Unit
Output supply voltage	V_{DDQ}		1.7	1.8	1.9	V
Supply voltage ¹	AV_{DD}			V_{DDQ}		
Low-level input voltage ²	V_{IL}	OE, OS, CK, \overline{CK}			$0.35 \times V_{DDQ}$	V
High-level input voltage ²	V_{IH}	OE, OS, CK, \overline{CK}	$0.65 \times V_{DDQ}$			
High-level output current	I_{OH}				-9	mA
Low-level output current	I_{OL}				9	mA
Input differential-pair cross voltage	V_{IX}		$(V_{DDQ}/2) - 0.15$		$(V_{DDQ}/2) + 0.15$	V
Input voltage level	V_{IN}		-0.3		$V_{DDQ} + 0.3$	
Input differential-pair voltage ² (see Figure 9)	V_{ID}	DC	0.3		$V_{DDQ} + 0.4$	
		AC	0.6		$V_{DDQ} + 0.4$	
Operating free-air temperature			0		70	°C

- The PLL is turned off and bypassed for test purposes when AV_{DD} is grounded. During this test mode, V_{DDQ} remains within the recommended operating conditions and not timing parameters are guaranteed.
- V_{ID} is the magnitude of the difference between the input level on CK and the input level on \overline{CK} , see Figure 12 for definition. For CK and \overline{CK} the V_{IH} and V_{IL} limits are used to define the DC low and high levels for the logic detect state.

Table 5. Electrical Characteristics over Recommended Free-Air Operating Temperature Range

Description	Parameter	Affected Pins	Test Conditions	AV _{DD} , V _{DDQ}	Min	Max	Unit
All inputs	V _{IK}		I _I = -18mA	1.7 V		-1.2	V
High output voltage	V _{OH}		I _{OH} = -100 μA	1.7 to 1.9 V	V _{DDQ} -0.2		V
			I _{OH} = -9 mA	1.7 V	1.1		
Low output voltage	V _{OL}		I _{OL} = 100 μA	1.7 to 1.9 V		0.1	V
			I _{OL} = 9 mA	1.7 V		0.6	
Output disable current	I _{ODL}		OE = L, V _{ODL} = 100 mV	1.7 V	100		μA
Output differential voltage	V _{OD}			1.7 V	0.5		V
Input leakage current	I _I	CK, \overline{CK}	V _I = V _{DDQ} or GND	1.9 V		± 250	μA
		OE, OS, FBIN, \overline{FBIN}	V _I = V _{DDQ} or GND	1.9 V		± 10	
Static supply current I _{DDQ} + I _{ADD}	I _{DDLD}		CK and \overline{CK} = L	1.9 V		500	μA
Dynamic Supply current I _{DDQ} + I _{ADD} , see Note 1 for CPD calculation	I _{DD}		CK and \overline{CK} = 270 MHz all outputs open	1.9 V		300	mA

NOTE: 1. Total I_{DD} = I_{DDQ} + I_{ADD} = F_{CK} * C_{PD} * V_{DDQ}, solving for C_{PD} = (I_{DDQ} + I_{ADD})/(F_{CK} * V_{DDQ}) where F_{CK} is the input Frequency, V_{DDQ} is the power supply and C_{PD} is the Power Dissipation Capacitance.

Table 6. Timing Requirements over Recommended Free-Air Operating Temperature Range

Timing Requirements	AV _{DD} , V _{DDQ} = 1.8 V ± 0.1 V		Unit
	Min	Max	
Operating clock frequency ^{1 2}	125	340	MHz
Application clock frequency ^{1 3}	160	340	MHz
Input clock duty cycle	40	60	%
Stabilization time ⁴		15	μs

1. The PLL must be able to handle spread spectrum induced skew.
2. Operating clock frequency indicates a range over which the PLL must be able to lock, but in which it is not required to meet the other timing parameters. (Used for low speed system debug.)
3. Application clock frequency indicates a range over which the PLL must meet all timing parameters.
4. Stabilization time is the time required for the integrated PLL circuit to obtain phase lock of its feedback signal to its reference signal after power up. During normal operation, the stabilization time is also the time required for the integrated PLL circuit to obtain phase lock of its feedback signal to its reference signal when CK and \overline{CK} go to a logic low state, enter the power-down mode and later return to active operation. CK and \overline{CK} may be left floating after they have been driven low for one complete clock cycle.

Table 7. Switching Characteristics over Recommended Free-Air Operating Temperature Range Unless Otherwise Noted (see Notes)

Description	Parameter	Diagram	$AV_{DD}, V_{DDQ} = 1.8 V \pm 0.1 V$			Unit
			Min	Nom	Max	
OE to any $\overline{Y/\overline{Y}}$	ten	see Figure 11			8	ns
OE to any $\overline{Y/\overline{Y}}$	tdis	see Figure 11			8	ns
Cycle-to-Cycle period jitter	tjit(cc+)	see Figure 4	0		40	ps
	tjit(cc-)		0		-40	ps
Static phase offset	t(ϕ)	see Figure 5	-50		50	ps
Dynamic phase offset	t(ϕ)dyn	see Figure 10	-50		50	ps
Output clock skew	tsk(o)	see Figure 6			40	ps
Period Jitter	tjit(per)	see Figure 7	-40		40	ps
Half -period jitter	tjit(hper)	see Figure 8	-75		75	ps
Output Enable	slr(i)	see Figures 3 and 9	0.5			V/ns
Input clock slew rate, measured single ended			1	2.5	4	
Output clock slew rate, measured single ended	slr(o)	see Figures 3 and 9	1.5	2.5	3	V/ns
Output differential-pair cross voltage	V_{OX}	see Figure 2	$(V_{DDQ}/2) - 0.1$		$(V_{DDQ}/2) + 0.1$	V
SSC modulation frequency			30		33	kHz
SSC clock input frequency deviation			0.0		-0.5	
PLL Loop bandwidth (-3dB from unity gain)			2.0			MHz

NOTES:

1. There are two different terminations that are used with the following tests. The loadboard in Figure 2 is used to measure the input and output differential-pair cross voltage only. The loadboard in Figure 3 is used to measure all other tests. For consistency, equal length cables must be used.
2. Static Phase offset does not include Jitter.
3. Period Jitter and Half-Period Jitter specifications are separate specifications that must be met independently of each other.
4. The Output Slew Rate is determined from the IBIS model into the load shown in Figure 4. It is measured single ended.
5. To eliminate the impact of input slew rates on static phase offset, the input slew rates of Reference Clock Input CK, \overline{CK} and Feedback Clock Input FBIN, \overline{FBIN} are recommended to be nearly equal. The 2.5 V/ns slew rates are shown as a recommended target. Compliance with these Nom values is not mandatory if it can be adequately demonstrated that alternative characteristics meet the requirements of the registered DDR2 DIMM application.

TEST CIRCUIT AND SWITCHING WAVEFORMS

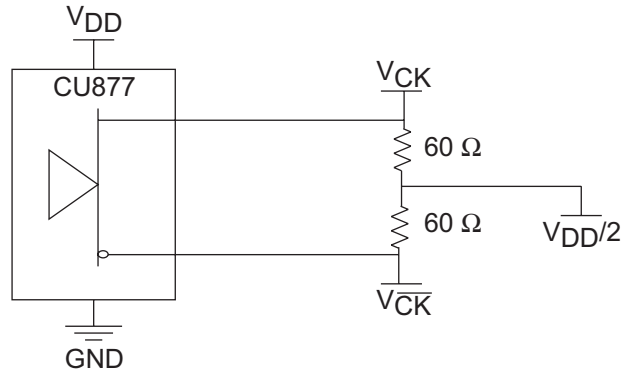

Figure 2. IBIS Model Output Load

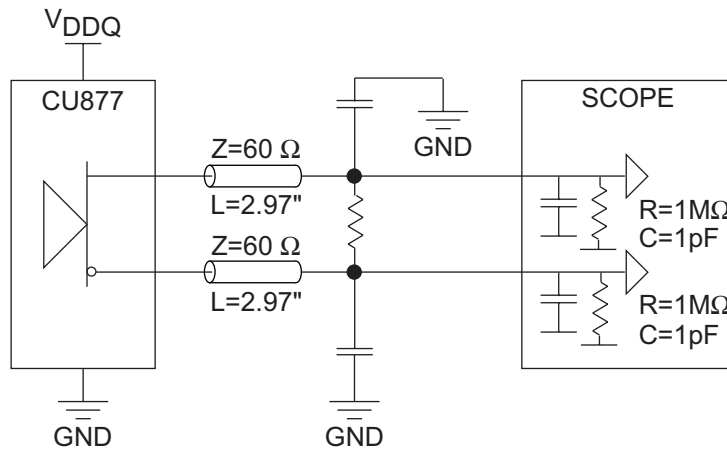
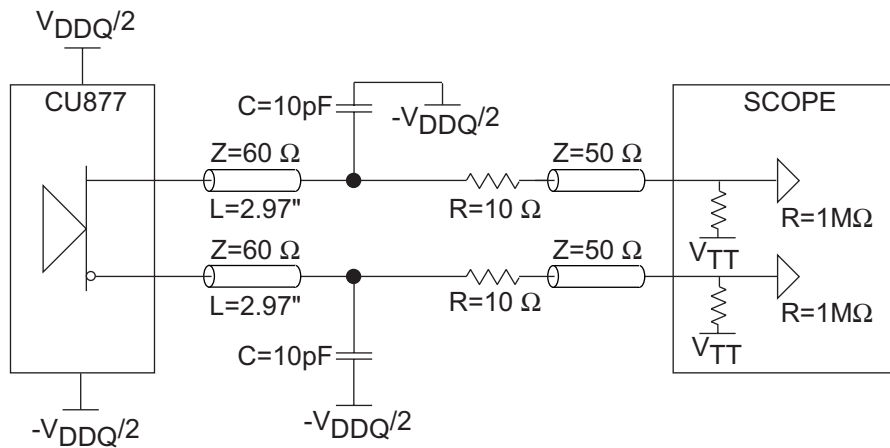

Figure 3. Output Load Test Circuit 1



Note: $V_{TT} = GND$

Figure 4. Output Load Test Circuit 2

TEST CIRCUIT AND SWITCHING WAVEFORMS (Continued)

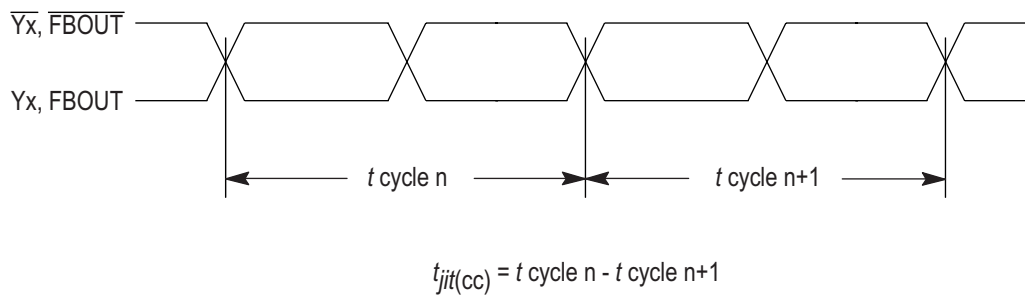
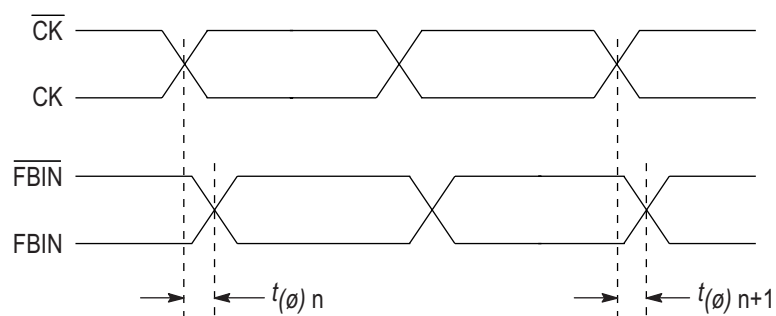

Figure 5. Cycle-to-Cycle Period Jitter



$$t_{(\phi)} = \frac{\sum_{n=1}^{n=N} t_{(\phi) n}}{N} \quad (N \text{ is a large number of samples})$$

Figure 6. Static Phase Offset

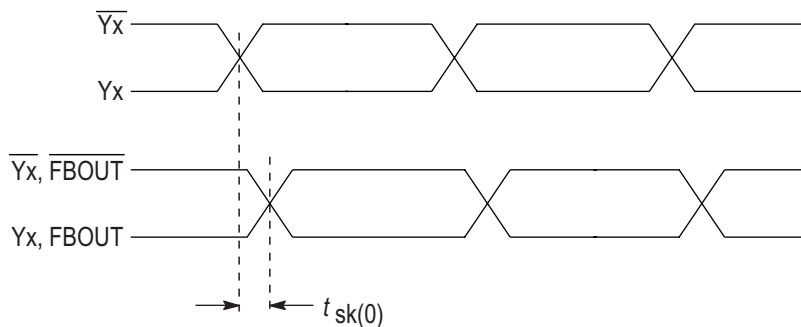

Figure 7. Output Skew

TEST CIRCUIT AND SWITCHING WAVEFORMS (Continued)

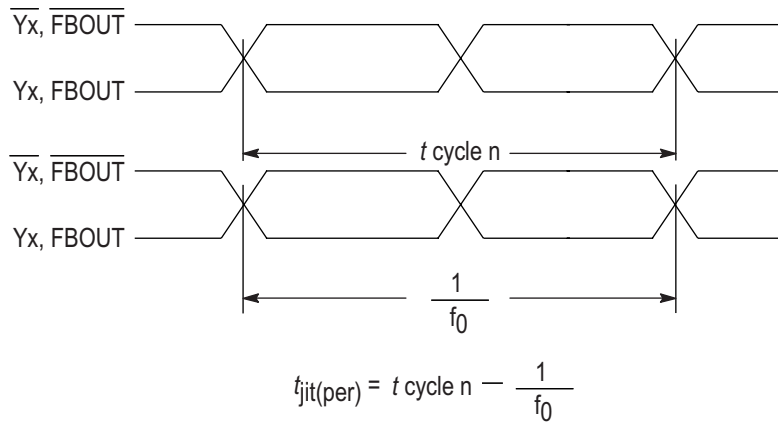

Figure 8. Period Jitter

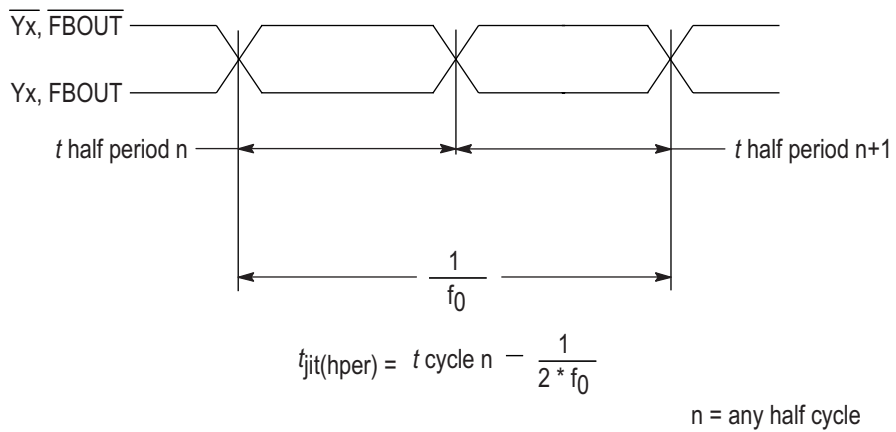

Figure 9. Half-Period Jitter

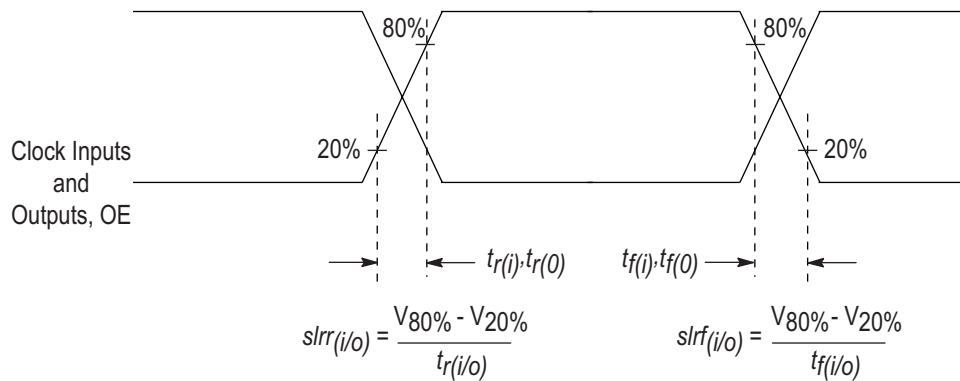

Figure 10. Input and Output Slew Rates

TEST CIRCUIT AND SWITCHING WAVEFORMS (Continued)

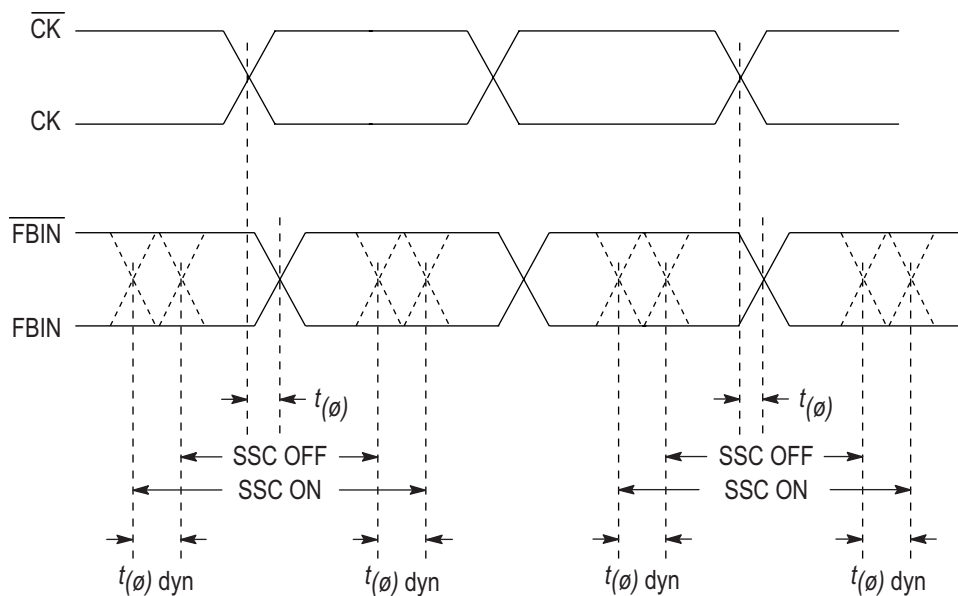

Figure 11. Dynamic Phase Offset

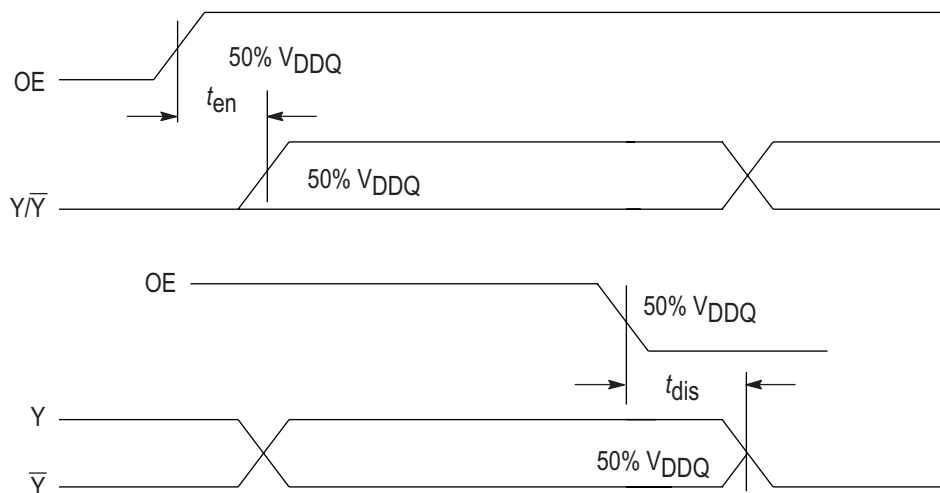
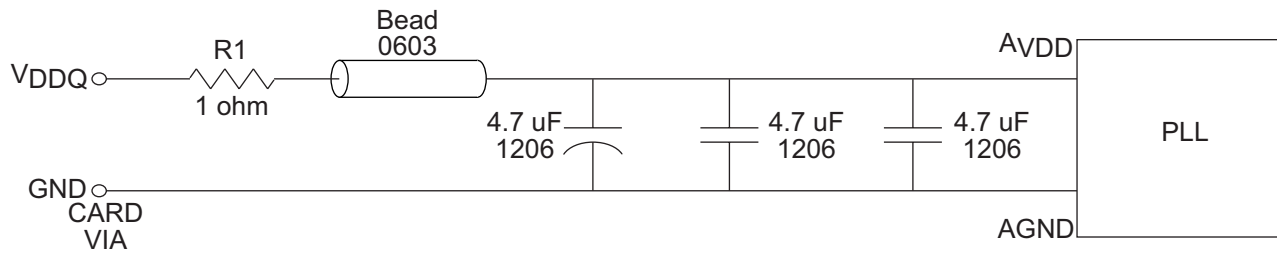

Figure 12. Time Delay between OE and Clock Output

RECOMMENDED FILTERING FOR THE ANALOG POWER SUPPLY (AV_{DD})**NOTES:**

1. Place the 2200pF capacitor close to the PLL
2. Use a wide trace for the PLL analog power and ground. Connect PLL and caps to AGND to AGND trace & connect trace to one GND via (farthest from PLL).
3. Recommended bead: Fair Rite P/N 2506036017Y0 or equivalent (0.8 Ohm DC max, 600 Ohms @ 100 MHz)

Figure 13. AV_{DD} Filtering

PACKAGE DIMENSIONS

VK SUFFIX
 52-BALL FP-MAPBGA
 NON-LEADED PACKAGE
 CASE 1544-01
 ISSUE O

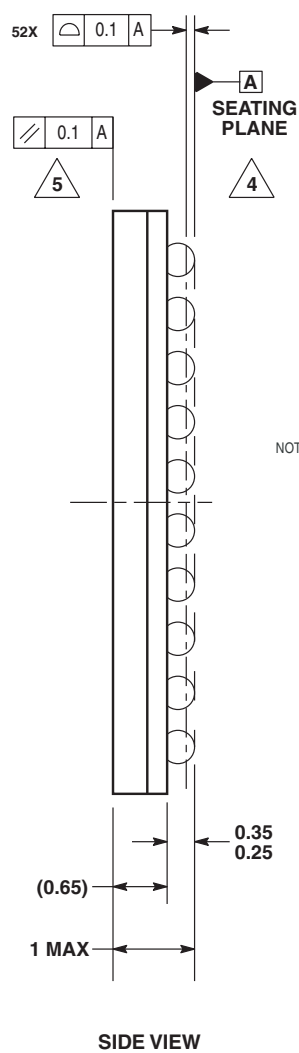
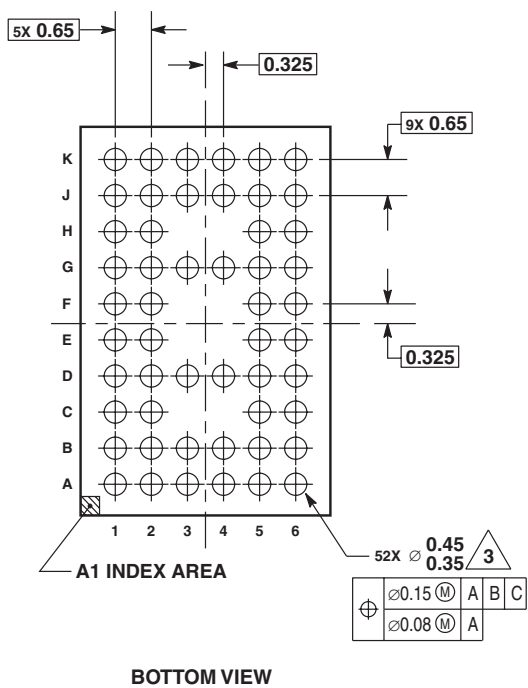
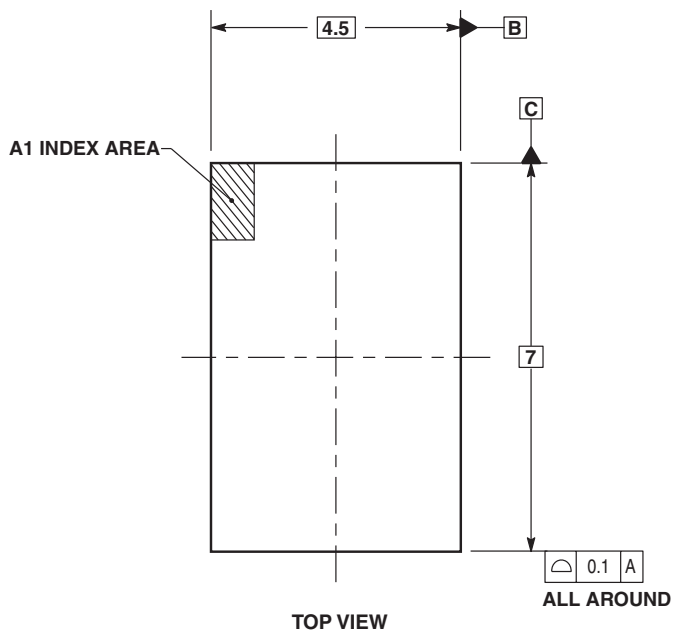

- NOTES:
1. ALL DIMENSIONS ARE IN MILLIMETERS.
 2. DIMENSIONING AND TOLERANCING PER ASME Y14.5M, 1994.
 3. MAXIMUM SOLDER BALL DIAMETER MEASURED PARALLEL TO DATUM A.
 4. DATUM A. THE SEATING PLANE, IS DETERMINED BY THE SPHERICAL CROWNS OF THE SOLDER BALLS.
 5. PARALLELISM MEASUREMENT SHALL EXCLUDE ANY EFFECT OF MARK ON TOP SURFACE OF PACKAGE.

EP SUFFIX
40-PIN MLF/QFN PACKAGE
CASE 1545-01

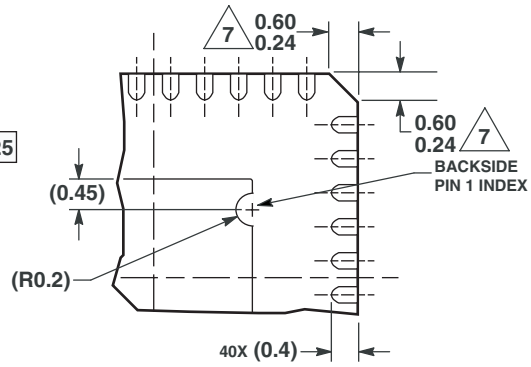
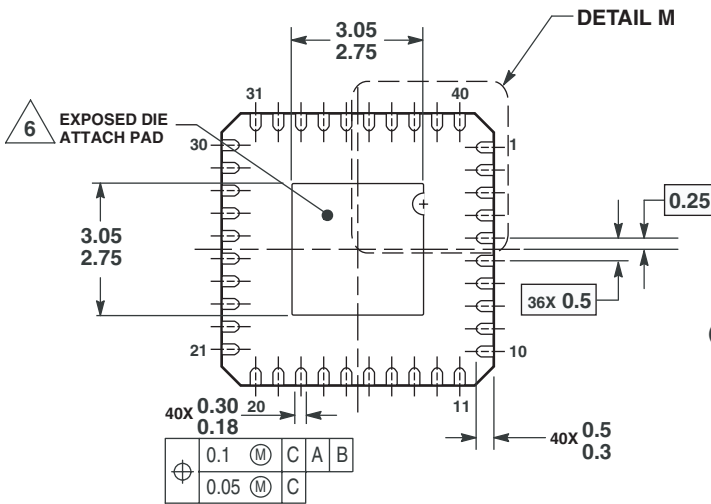
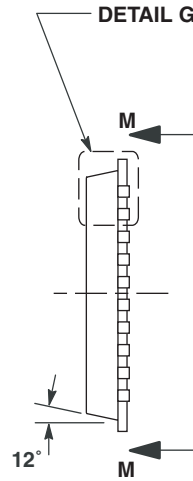
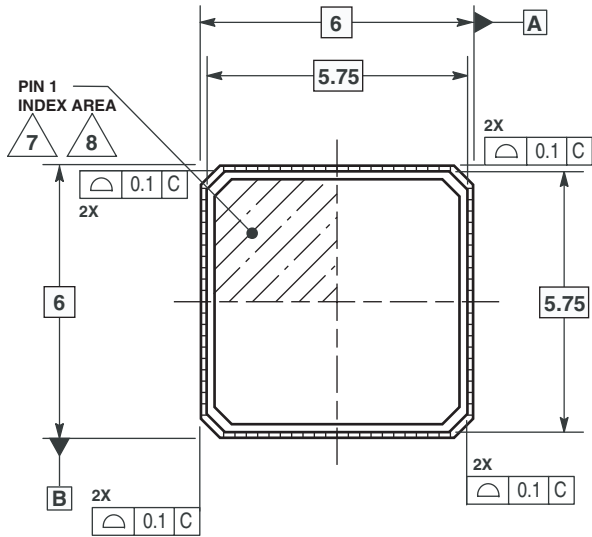

DETAIL M
PREFERRED BACKSIDE PIN 1 INDEX

VIEW M-M

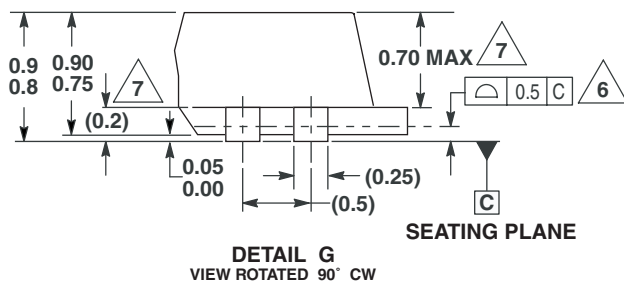

DETAIL G
VIEW ROTATED 90° CW

NOTES:

1. ALL DIMENSIONS ARE IN MILLIMETERS.
2. DIMENSIONING AND TOLERANCING PER ASME Y14.5M, 1994.
3. MAXIMUM PACKAGE WARPAGE IS 0.05 mm.
4. MAXIMUM ALLOWABLE BURRS IS 0.0706 mm IN ALL DIRECTIONS.
5. THIS DIMENSION APPLIES TO METALLIZED TERMINAL AND IS MEASURED BETWEEN 0.20 mm AND 0.25 mm FROM TERMINAL TIP. IF THE TERMINAL HAS THE OPTIONAL RADIUS ON THE OTHER END OF THE TERMINAL, THIS DIMENSION SHOULD NOT BE MEASURED IN THAT RADIUS AREA.
6. COPLANARITY APPLIES TO LEADS, CORNER LEADS AND DIE ATTACH PAD.
7. EXACT SHAPE AND SIZE OF THIS FEATURE IS OPTIONAL.
8. THE PIN #1 IDENTIFIER MUST BE EXISTED ON THE TOP SURFACE OF THE PACKAGE BY USING INDENTATION MARK OR OTHER FEATURE OF PACKAGE BODY.
9. DIE THICKNESS ALLOWABLE IS 0.305 mm MAXIMUM.

NOTES

Information in this document is provided solely to enable system and software implementers to use Motorola products. There are no express or implied copyright licenses granted hereunder to design or fabricate any integrated circuits or integrated circuits based on the information in this document.

Motorola reserves the right to make changes without further notice to any products herein. Motorola makes no warranty, representation or guarantee regarding the suitability of its products for any particular purpose, nor does Motorola assume any liability arising out of the application or use of any product or circuit, and specifically disclaims any and all liability, including without limitation consequential or incidental damages. "Typical" parameters which may be provided in Motorola data sheets and/or specifications can and do vary in different applications and actual performance may vary over time. All operating parameters, including "Typicals" must be validated for each customer application by customer's technical experts. Motorola does not convey any license under its patent rights nor the rights of others. Motorola products are not designed, intended, or authorized for use as components in systems intended for surgical implant into the body, or other applications intended to support or sustain life, or for any other application in which the failure of the Motorola product could create a situation where personal injury or death may occur. Should Buyer purchase or use Motorola products for any such unintended or unauthorized application, Buyer shall indemnify and hold Motorola and its officers, employees, subsidiaries, affiliates, and distributors harmless against all claims, costs, damages, and expenses, and reasonable attorney fees arising out of, directly or indirectly, any claim of personal injury or death associated with such unintended or unauthorized use, even if such claim alleges that Motorola was negligent regarding the design or manufacture of the part.

MOTOROLA and the Stylized M Logo are registered in the US Patent and Trademark Office. All other product or service names are the property of their respective owners.

© Motorola, Inc. 2004

HOW TO REACH US:

USA/EUROPE/LOCATIONS NOT LISTED:
Motorola Literature Distribution
P.O. Box 5405, Denver, Colorado 80217
1-800-521-6274 or 480-768-2130

JAPAN: Motorola Japan Ltd.; SPS, Technical Information Center
3-20-1 Minami-Azabu, Minato-ku, Tokyo 106-8573, Japan
81-3-3440-3569

ASIA/PACIFIC: Motorola Semiconductors H.K. Ltd.; Silicon Harbour Centre
2 Dai King Street, Tai Po Industrial Estate, Tai Po, N.T., Hong Kong
852-26668334

HOME PAGE: <http://motorola.com/semiconductors>



MOTOROLA

MPC96877