

I²C-Bus INTERFACE REAL TIME CLOCK MODULE

RX - 8581 SA / JE / NB

- Built-in frequency adjusted 32.768 kHz crystal unit.
 - Interface Type : I²C-Bus Interface (400 kHz)
 - Operating voltage range : 1.8 V to 5.5 V
 - Wide Timekeeper voltage range : 1.6 V to 5.5 V
 - Low backup current : 0.45 μA / 3 V (Typ.)
 - 32.768 kHz frequency output function : C-MOS output With Control Pin
 - The various functions include full calendar, alarm, timer.
 - Lead(Pb)-free : Contains high melting temperature type solder (Pb85 %) exempted by RoHS directive.
- * The I²C-Bus is a trademark of Philips Electronics N.V.



Actual size



Block diagram

Overview

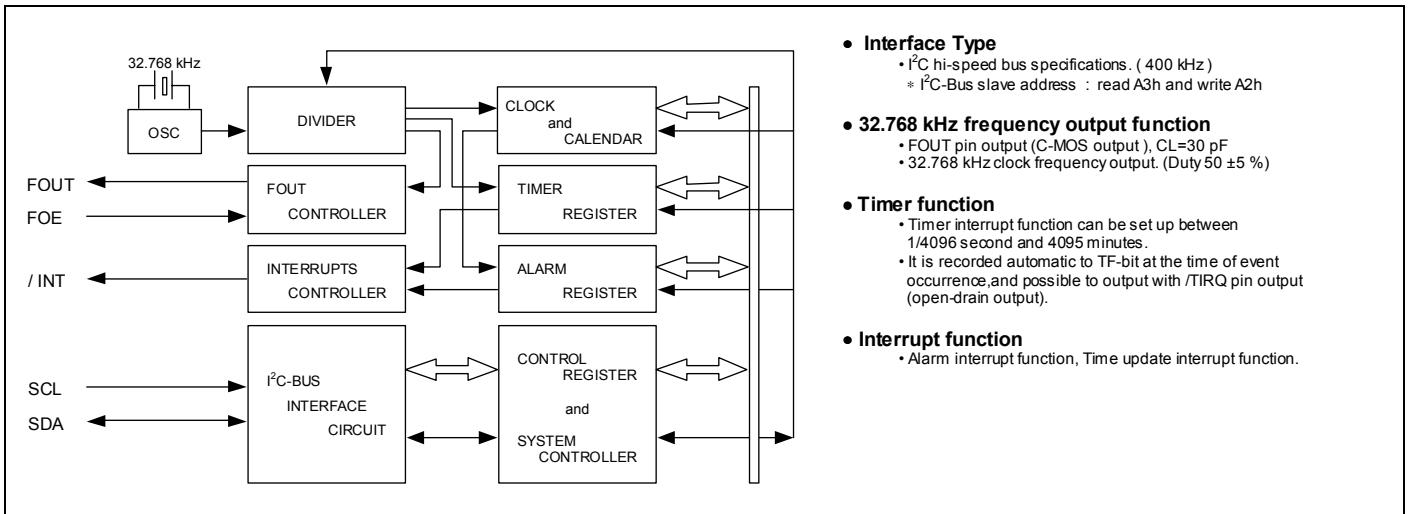

- **Interface Type**
 - I²C hi-speed bus specifications. (400 kHz)
 - I²C-Bus slave address : read A3h and write A2h
- **32.768 kHz frequency output function**
 - FOUT pin output (C-MOS output), CL=30 pF
 - 32.768 kHz clock frequency output. (Duty 50 ± 5 %)
- **Timer function**
 - Timer interrupt function can be set up between 1/4096 second and 4095 minutes.
 - It is recorded automatic to TF-bit at the time of event occurrence, and possible to output with /TIRQ pin output (open-drain output).
- **Interrupt function**
 - Alarm interrupt function, Time update interrupt function.

Terminal connection / External dimensions

(Unit:mm)

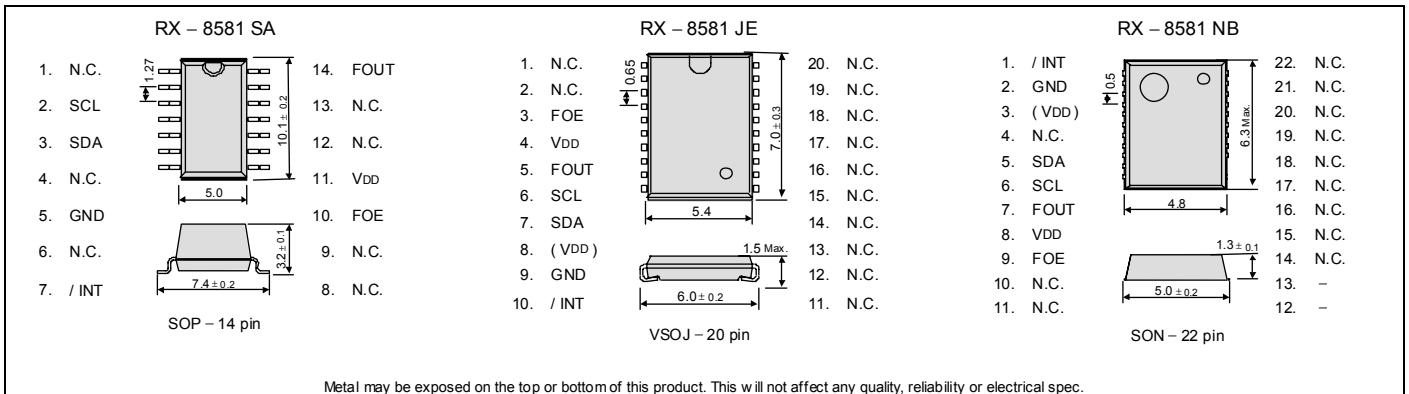

Metal may be exposed on the top or bottom of this product. This will not affect any quality, reliability or electrical spec.

Specifications (characteristics)

* Refer to application manual for details.

■ Recommended Operating Conditions

Item	Symbol	Condition	Min.	Typ.	Max.	Unit
Power voltage	V _{DD}	—	1.8	3.0	5.5	V
Clock voltage	V _{CLK}	—	1.6	3.0	5.5	V
Operating temperature	T _{OPR}	—	-40	+25	+85	°C

■ Frequency characteristics

Item	Symbol	Condition	Rating	Unit
Frequency tolerance	Δf/f	T _a = +25 °C V _{DD} = 3.0 V	5 ± 23 *	× 10 ⁻⁶
FOUT output Duty	tw / t	T _a = -40 °C to +85 °C V _{DD} = 2.4 V to 5.5 V	50 ± 5	%

* Please ask for tighter tolerance. (Equivalent to 1 minute of monthly deviation)

■ DC characteristics

T_a = -40 °C to +85 °C

Item	Symbol	Condition	Min.	Typ.	Max.	Unit
Current Consumption	I _{BK}	f _{SCL} = 0 Hz FOE = GND FOUT ; output OFF (LOW)	V _{DD} = 5 V	0.65	1.2	μA
			V _{DD} = 3 V	0.45	0.8	
Current Consumption	I _{32k}	f _{SCL} = 0 Hz FOE = V _{DD} FOUT ; 32.768 kHz output ON CL = 30 pF	V _{DD} = 5 V	8.0	20.0	μA
			V _{DD} = 3 V	5.0	12.0	

End to End EPSON TOYOCOM

The development of our ubiquitous network society has caused a diversification of applications and has increased the demand for high-level quartz devices in terms of quality, quantity, and function.

The Quartz Device Operations Division of SEIKO EPSON CORPORATION (EPSON) and TOYO COMMUNICATION EQUIPMENT CO., LTD. (TOYOCOM) were integrated on October 1, 2005 to establish a new company, EPSON TOYOCOM CORPORATION, to meet these market and customer demands.

Each company contributes its own strength; EPSON holds a strong presence in consumer products and TOYOCOM is strong in industrial products. The consolidation of these two companies in a new company that provides advanced expertise with a wide range of products for terminals and infrastructure to our

customers.

Quartz devices have become crucial in the network environment where products are increasingly intended for broadband, ubiquitous applications and where various types of terminals can transfer information almost immediately via LAN and WAN on a global scale. EPSON TOYOCOM CORPORATION addresses every single aspect within a network environment. The new corporation offers "end-to-end" solutions to problems arising with products for consumer use, such as core network systems and automotive systems.

PROMOTION OF ENVIRONMENTAL MANAGEMENT SYSTEM CONFORMING INTERNATIONAL STANDARD

At EPSON TOYOCOM, all environmental initiatives operate under the Plan-Do-Check-Action (PDCA) cycle designed to achieve continuous improvements. The environmental management system (EMS) operates under the ISO 14001 environmental management standard.

In May 2001, all of our major manufacturing and non-manufacturing sites, in Japan and overseas, completed the acquisition of ISO 14001 certification. In the future, new group companies will be expected to acquire the certification around the third year of operations.

ISO 14000 is an international standard for environmental management that was established by the International Standards Organization in 1996 against the background of growing concern regarding global warming, destruction of the ozone layer, and global deforestation.

WORKING FOR HIGH QUALITY

EPSON TOYOCOM quickly began working to acquire company-wide ISO 9000 series certification, and has acquired ISO 9001 or ISO 9002 certification with all targeted products manufactured in Japanese and overseas plants.

The Quartz Device Operations Division (In Japan, EPM and SZE) have acquired QS-9000 certification, which are of higher Level. Also QS-9000 and TS 16949 certification, which is of higher level, has been acquired.

QS-9000 is an enhanced standard for quality assurance systems formulated by leading U.S. automobile manufacturers based on the international ISO 9000 series.

ISO/TS 16949 is a global standard based on QS-9000, a severe standard corresponding to the requirements from automobile industry.

Notice

- The material is subject to change without notice.
- Any part of this material may not be reproduced or duplicated in any form or any means without the written permission of EPSON TOYOCOM.
- The information, applied circuit, program, usage etc., written in this material is just for reference. EPSON TOYOCOM does not assume any liability for the occurrence of infringing any patent or copyright of a third party. This material does not authorize the licensing for any patent or intellectual copyrights.
- Any product described in this material may contain technology or the subject relating to strategic products under the control of the Foreign Exchange and Foreign Trade Law of Japan and may require an export licence from the Ministry of International Trade and Industry or other approval from another government agency.
- These products are intended for general use in electronic equipment. When using them in specific applications that require extremely high reliability such as applications stated below, it is required to obtain the permission from EPSON TOYOCOM in advance.
/ Space equipment (artificial satellites, rockets, etc) / Transportation vehicles and related (automobiles, aircraft, trains, vessels, etc)
/ Medical instruments to sustain life / Submarine transmitters / Power stations and related / Fire work equipment and security equipment
/ traffic control equipment / and others requiring equivalent reliability.
- In this new crystal master for EPSON TOYOCOM, product code and marking will still remain as previously identified prior to the merger. Due to the on going strategy of gradual unification of part numbers, please review product code and marking as they will change during the course of the coming months.
We apologize for the inconvenience, but we will eventually have a unified part numbering system for Epson Toyocom which will be user friendly.