

Product Description

The Sirenza Microdevices' SLX-2043 is a low noise amplifier module operating in the 1700 - 2200 MHz frequency band. This device has been optimized to serve high linearity basestation applications where a high intercept point is required with low noise figure. The SLX-2043 uses PHEMT device technology, internal bias circuitry, and proven ceramic module technology to yield a high performance product with proven reliability. Internal RF matching is also included on both the input and output to provide an easy to implement, unconditionally stable, 50 ohm circuit block.

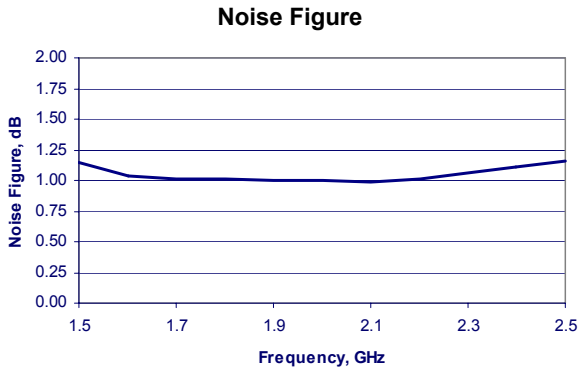

SLX-2043

1700-2200 MHz High Linearity Low Noise Amplifier Module



Product Features

- Very Low Noise Figure, 1.05dB
- OIP₃ = +35dBm
- Gain = 15dB
- 50Ω Input/Output match
- Single Supply Operation

Applications

- PCS, TDMA, CDMA, WCDMA receivers

Product Specifications

Symbol	Parameters	Unit	Min.	Typ.	Max.	Min.	Typ.	Max.
F _O	Frequency Range	GHz	1.7		2.0	>2.0		2.2
S ₂₁	Gain	dB	13.5	15	16.5	13	14.5	16
S ₁₁	Input Return Loss	dB	9	12	-	9	12	-
S ₂₂	Output Return Loss	dB	10	13	-	10	13	-
NF	Noise Figure	dB	-	1.05	1.3	-	1.05	1.3
OIP ₃	Output Third Order Intercept Point	dBm	32	35	-	33	35	-
P _{1dB}	Compression Point	dBm		20			19	
GD	Group Delay	ns		<0.5			<0.5	
	Deviation from Linear Phase (over 100MHz)	degrees		<0.15			<0.1	
S ₁₂	Reverse Isolation	dB		-23			-23	
V _{dd}	Supply Voltage	V	3.8	4	4.2			
I _{dd}	Supply Current	mA	90	108	120			
R _{th}	Thermal Resistance (junction-lead)	°C/W		60				

All parameters measured in a 50 ohm system, V_{dd}=4V, T=25°C. OIP₃ measured at a power of 6dBm per tone, 6MHz tone spacing.
NOTE: For applications between 2.2 - 2.5GHz please contact WIP-APPS@sirenzamicro.com

The information provided herein is believed to be reliable at press time. Sirenza Microdevices assumes no responsibility for inaccuracies or omissions. Sirenza Microdevices assumes no responsibility for the use of this information, and all such information shall be entirely at the user's own risk. Prices and specifications are subject to change without notice. No patent rights or licenses to any of the circuits described herein are implied or granted to any third party. Sirenza Microdevices does not authorize or warrant any Sirenza Microdevices product for use in life-support devices and/or systems.

Copyright 2002 Sirenza Microdevices, Inc. All worldwide rights reserved.
522 Almanor Ave., Sunnyvale, CA 94085

Phone: (800) SMI-MMIC

Absolute Maximum Ratings

Parameters	Value	Unit
Supply Current (I _{dd})	150	mA
Device Voltage (V _{dd})	5.0	V
Operating Temperature	-40 to +85	°C
Storage Temperature Range	-65 to +150	°C
Peak Reflow Temperature (30sec)	+230	°C
Operating Junction Temperature	+150	°C
Maximum Input Power	+21	dBm

Subjecting this device at or beyond any one of these limits may cause permanent damage. For reliable operation, the device operating voltage and current must not exceed the maximum values shown in the “ProductSpecifications” table.

Bias conditions should also satisfy the following expression:

$V_{DD} I_{DD} R_{TH} < T_J - T_{OP}$ where T_J is the junction temperature (150°C) and T_{OP} is the board temperature.

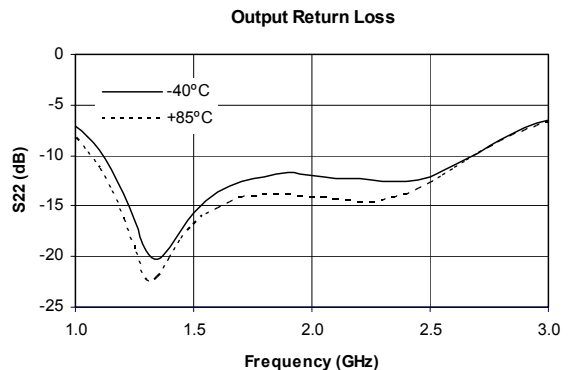
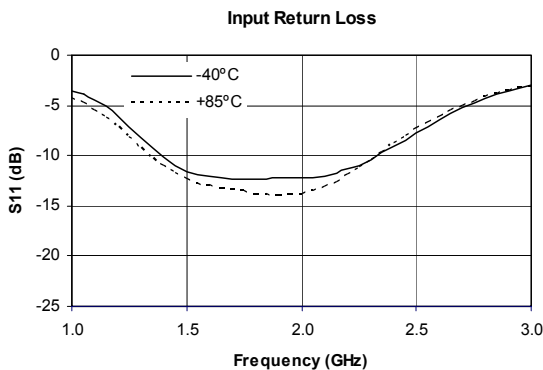
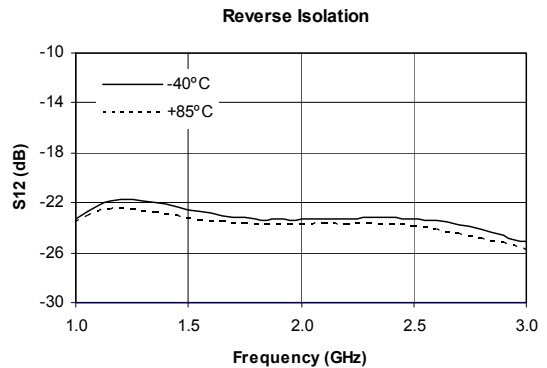
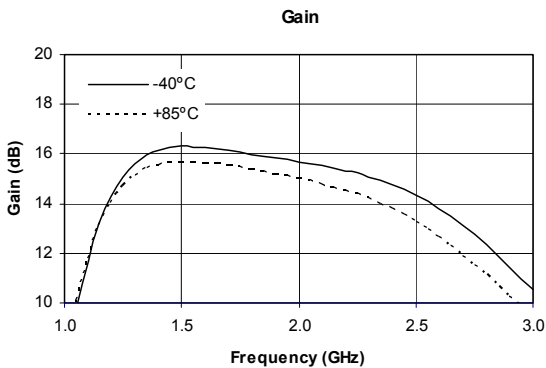

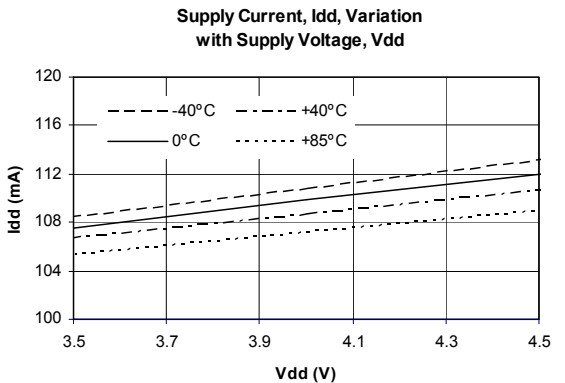
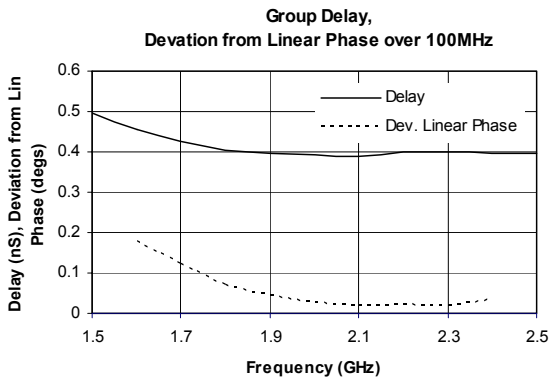
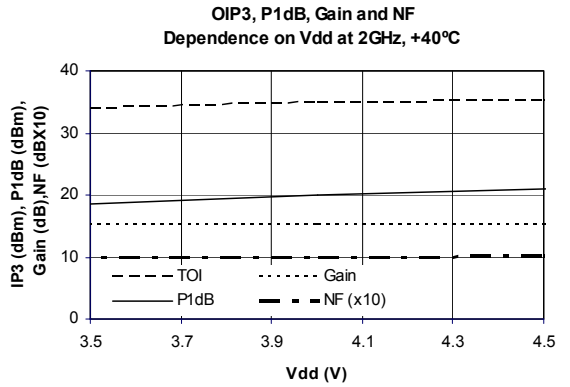
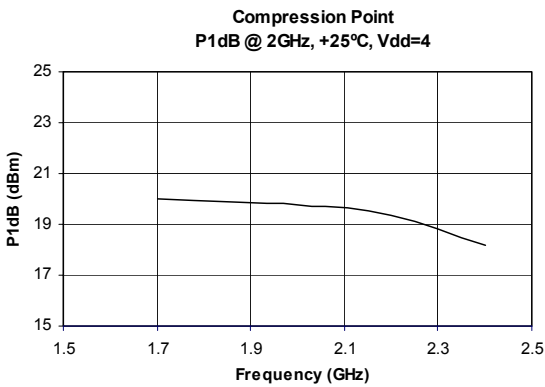
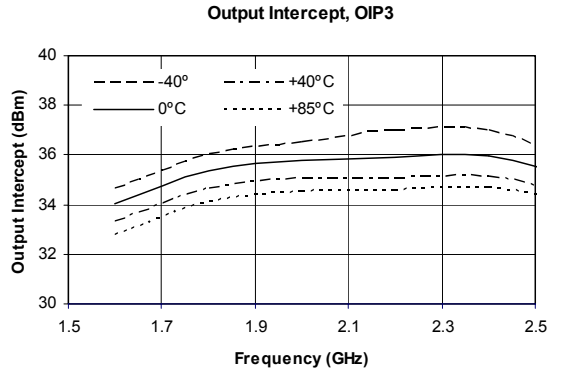
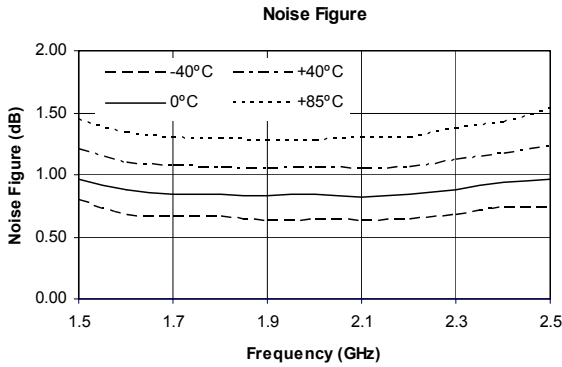



Caution: ESD Sensitive
 Appropriate precaution in handling, packaging and testing devices must be observed.

Part Number Ordering Information

Part Number	Reel Size	Devices/Reel
SLX-2043	7"	500

Part Symbolization

The part will be symbolized with an "SLX2043" on the top surface of the package.

Pin #	Function	Description	Device Schematic
1	RF In	RF input pin. This pin is at DC ground. An external DC blocking capacitor should be used in most applications.	
2	RF Out/ DC Input	RF output and bias pin. Bias should be supplied to this pin through an external RF choke inductor. Because DC biasing is present on this pin, a DC blocking capacitor should be used in most applications (see application schematic). The supply side of the bias network should be well bypassed.	
3 Package Backside	GND	Connection to RF/DC ground. For best performance use via holes as shown in recommended PCB layout to reduce inductance and to provide adequate thermal path.	

Package Dimensions ("43" Ceramic Module)

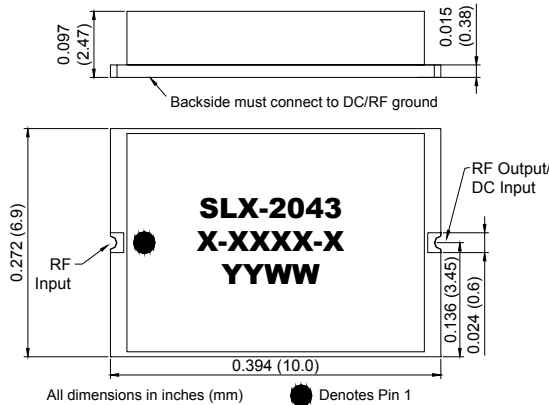

Test PCB Pad Layout

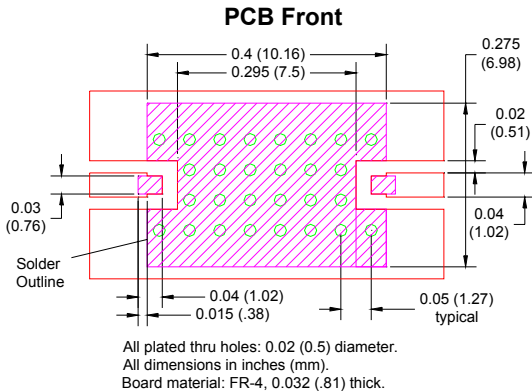

Package Back

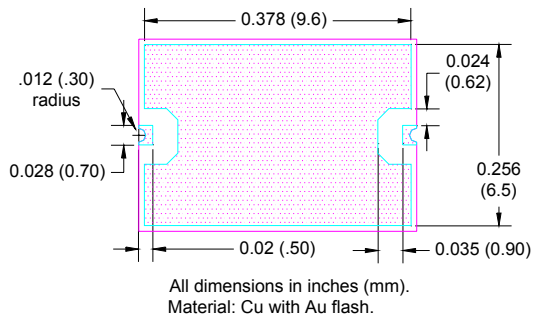

1.7GHz to 2.2GHz Application Schematic

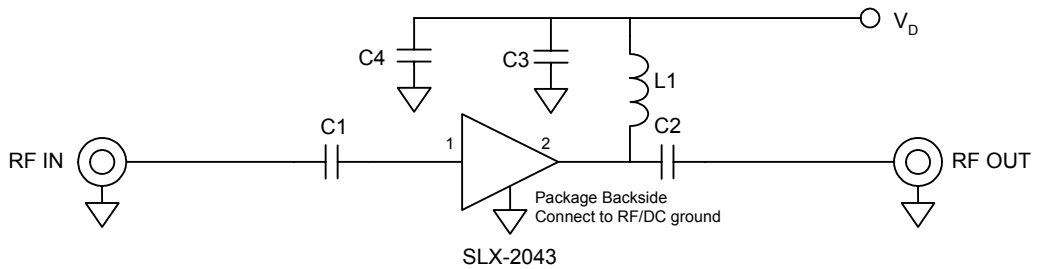

Bill of Materials

Component Designator	Value	Qty	Vendor	Part Number	Description
U1		1	SMDI	SLX-2043	High linearity low noise amplifier
S1, S2		2	Johnson Components	142-0701-851	SMA side mount connector
C1, C2	10 pF	2	Kemet	C0603C100J5GAC	0603 capacitor
C3	220 pF	1	Kemet	C0603C221J5GAC	0603 capacitor
C4	0.01 uF	1	Kemet	C0603C103K5RAC	0603 capacitor
R1	0Ω	1	Panasonic	POOGCTND	0603 jumper
J1		1	Sullins	S1312-2-ND	2 pin header
L1	47 nH	1	TOKO	LL1608-F47NK	0603 inductor

1.7GHz to 2.2GHz Test Board P/N EEB102232

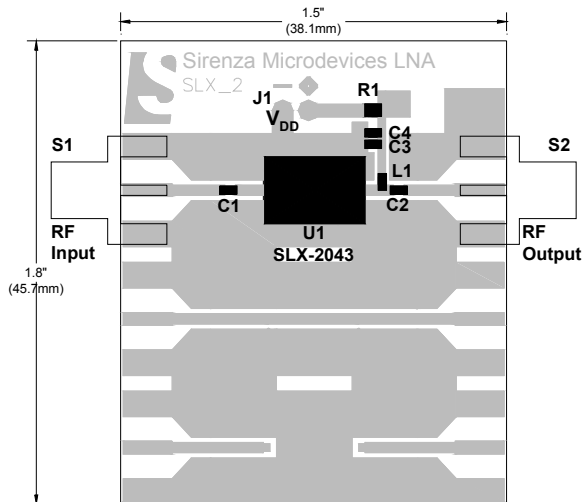

Abstract

This application note describes the components and materials that make up the SLX-2043 low noise amplifier module. It also describes the circuit board layout required for optimum performance, and procedures for the reliable solder attachment.

Introduction

The SLX is a thick film hybrid low noise amplifier designed for 1.7 - 2.2GHz applications that require both low noise figure and good linearity. This module is based on conventional thick film circuit fabrication methods, and can be surface mounted onto circuit boards using industry standard solder reflow techniques. In order to extract peak performance from this amplifier, it is important to use an appropriate circuit board layout, and to ensure that the part is soldered down correctly. Please contact wip-apps@sirenza-micro.com if your application is between 2.2 - 2.5 GHz.

Materials

The base of the SLX-2043 is an alumina (ceramic) "thick film" substrate, 0.015" (.38mm) thick. The back of this substrate is metallized with plated copper (on a base layer of fired silver) that has been protected with a thin flash of nickel and gold to guarantee solderability, even after extended storage time. The ceramic substrate has via holes that are filled with a fired silver compound. On the component side of the substrate (the side that is covered with the lid) there are conductors based on plated copper (that are protected with a flash of nickel-gold), and pure gold conductors. The copper conductors are formed by plating copper onto a silver conductor that has been fired into the substrate. The fired silver base ensures excellent adhesion to the substrate, and the plated copper ensures that the silver is completely protected. The gold conductors are fired into the substrate and are used wherever wire bonds are required. Thick film resistors are also integrated onto this substrate. A glass passivation layer is used for additional protection, and to act as a solder dam.

Inside the module there are several different types of components in use. Solder terminated "0402" capacitors and inductors are held down with high temperature lead free (96.5% Sn 3.5% Ag) solder. Discrete PHEMT transistors (in bare die format) are held down with conductive silver epoxy and are connected to the rest of the circuit with gold wire-bonds. There is one microwave single layer

capacitor that is also wirebonded and attached with conductive epoxy.

The module is sealed with a plastic (Vectra) lid that is held down with a B-stage epoxy seal ring. The overall module is non-hermetic, but it will pass a standard "bubble" leak test.

The module is designed to be reflowed onto a laminate based circuit board such as FR4. Input and output connections to the module are made with "castellations" on either end of the module. Castellations are rounded metalized notches (metalized with silver, copper, nickel, gold, as in other parts of the module) in the edge of the ceramic substrate. When these are put through a solder reflow process, the solder tends to wick up into the notches, creating a solder fillet that can be easily inspected. The third connection, ground, is formed by the rest of the metal on the back of the module.

Board Design

As the module has the input, output, and ground connections on the same plane, in principal coplanar waveguide should be used to feed the module. In practice, ground vias under the module connect the "top" ground to a microstrip ground plane. Care still needs to be taken to ensure a graceful transition from microstrip to coplanar waveguide. Care also needs to be taken to ensure that the medium leading up to the module (be it microstrip, coplanar waveguide, or grounded coplanar waveguide) is 50 ohms, with minimal loss. The dimensions used in the evaluation board are recommended (they yield a return loss of 27dB at 2 GHz) if that material structure can be adapted.

The evaluation board layout is shown in Figure 1. The DC blocks, bias inductor, and decoupling capacitors are also shown on the board. The coplanar line leading up to the module has a width of 0.04" (1.0mm) with a spacing of 0.02" (0.5mm) to the coplanar ground. The thickness of the board dielectric, FR4, is 0.032" (0.81mm), although typically the overall board thickness is increased with additional layers. One ounce copper is used on both sides. At 2.5GHz, the performance of the FR-4 board material is becoming marginal, so users may find it necessary to adjust the tuning of the part with external tuning elements if operating at this frequency.

Sirenza Microdevices will provide the detailed layout (in AutoCAD format) to users wishing to use the same layout and materials.

Figure 1: Evaluation Board Layout

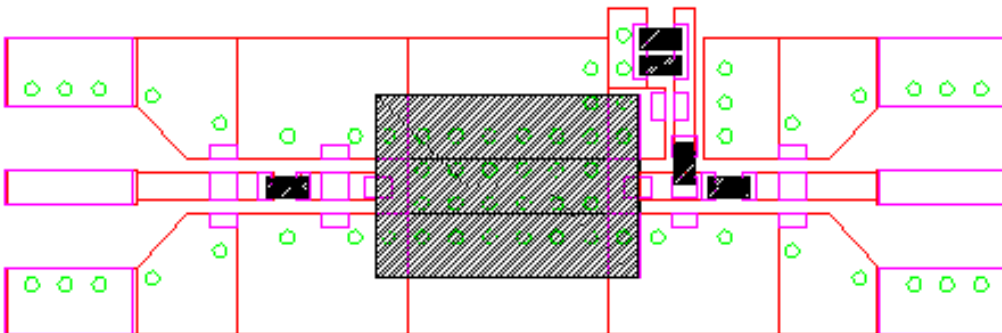

Solder Reflow

The module is designed to be soldered onto a pad that has an array of via holes for improved grounding. Note that the module is reasonably tolerant of voids in the solder coverage on the back, but that voids should be avoided because they can result in an increase in thermal impedance, which will result in the module running too hot. The gold content on the back is very small so solder embrittlement will not be a problem.

The module can be assembled onto a circuit board using standard oven or IR reflow profiles. It is difficult to recommend any single reflow profile because such profiles depend on the board size, other components on the board, and the reflow equipment in use. The most critical parameter is the peak temperature. The lid can become deformed if the peak temperature exceeds 230°C. Reflow profiles that have a peak temperature on the order of 220°C for 30 seconds will be adequate for this part. Lower peak temperatures can be used if the time is increased. For small volume prototype fabrication and rework, a hot plate running at about 250°C is recommended, with the part left on only until the solder reflows. Soldering irons are not recommended for mounting or removing the part.

There is a thermal coefficient of expansion mismatch between the module and typical circuit board material, but the small dimensions of the module make the strain induced into the module minimal, so no problems should be encountered. If the module is mounted on a very thin laminate (such as FR-4 0.032" (0.81mm) or less), then care should be taken to avoid flexing the laminate, as the ceramic substrate could crack. This has not been observed on conventional thick substrate materials. (The evaluation board is a three layer structure with two .032" thick dielectric layers.)

Conclusion

The SLX-2043 has been designed to be both easy to use and robust, and lab tests done at Sirenza Microdevices have repeatedly demonstrated this. By following the guidelines in this application note, excellent performance can be achieved. We hope that this application note and the products offered by Sirenza Microdevices will assist you in achieving your design goals. If there are any questions about this module or any other Sirenza Microdevices part, please contact us at wip-apps@sirenza.com.