

VX-706

Features

- AT-Cut Crystal
- Surface Mount FR4 based package
- Single layer
- Reflow Process Compatible
- Low Phase Noise & Jitter
- Tight Stabilities
- Frequency Range 40 - 300MHz
- Standard Frequencies 61,44; 100; 122,88; 153,6; 200; 250; 300MHz

Applications

- Industrial
- Synthesizers
- Test & Measurement
- Military

Performance Specifications

Frequency Stabilities ¹					
Parameter	Min	Typical	Max	Units	Condition
vs. operating temperature range (referenced to +25°C)	-30		+30	ppm	-40 to +85°C
Initial tolerance	-15		+15	ppm	@V _c =V _s /2 V _s ±5% Load ±10%
vs. supply voltage change	-3		+3	ppm	
vs. load change	-2		+2	ppm	
vs. aging / 1 Year	-2		+2	ppm	
vs. aging (15 years)	-8		+8	ppm	

Performance Specifications

Supply Voltage (Vs)						
Parameter	Min	Typical	Max	Units	Condition	
Supply voltage (standard)	3.135	3.3	3.465	VDC		Options
Current consumption			20	mA	@ HCMOS	
Current consumption			100	mA	@ PECL	
Supply voltage	4.75	5	5.25	VDC		
Current consumption			15	mA	@ HCMOS	
Current consumption			65	mA	@ PECL	
RF Output						
Signal	HCMOS					Options
Load		15		pF		
Rise and Fall time			5	ns	@ 15 pF 10 to 90%	
Duty cycle	45		55	%	@ Vs / 2	
Signal	PECL					
Load		50		Ω		
Rise and Fall time			1	ns	20 to 80%	
Duty cycle	45		55	%		
Frequency Tuning (EFC)						
Tuning Range	±60.0	±100	±200.0	ppm		
Linearity	10 %					
Tuning Slope	Positive					
Control Voltage Range	0 0.5	1.65 2.5	3.3 4.5	VDC VDC	with Vs = 3.3V with Vs = 5V	
Frequency Control Input Impedance	100			kΩ		
Additional Parameters						
Phase Noise		-72 -105 -132 -154 -164 -166		dBc/Hz dBc/Hz dBc/Hz dBc/Hz dBc/Hz dBc/Hz	10 Hz 100 Hz 1 kHz 10 kHz 100 kHz 1 MHz	@122.88 MHz LVCMOS 3.3V
Jitter		0.042		ps RMS	@ 12kHz .. 20MHz	
Phase Noise		-74 -104 -133 -154 -160 -162		dBc/Hz dBc/Hz dBc/Hz dBc/Hz dBc/Hz dBc/Hz	10 Hz 100 Hz 1 kHz 10 kHz 100 kHz 1 MHz	@ 122.88 MHz PECL 3.3V
Jitter		0.064		ps RMS	@ 12kHz .. 20MHz	
Weight			1.0 g			
Processing & Packing	Handling & Processing Note					
Absolute Maximum Ratings						
Supply voltage (Vs)			6.0	V		
Operable Temperature Range	-40		+85	°C		
Storage Temperature Range	-40		+95	°C		

Standard Shipping Method

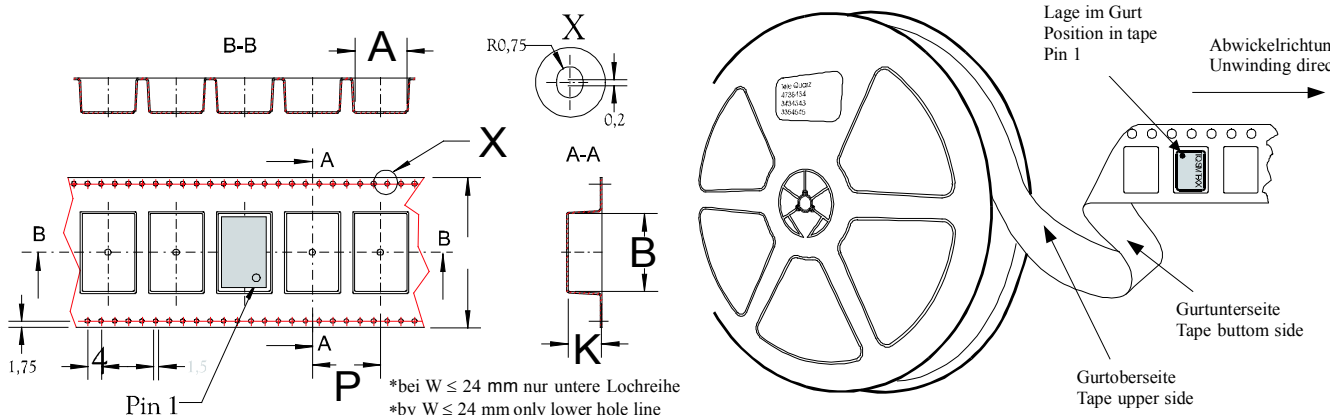

Enclosure Type	Tape Width W (mm)	Quantity per meter	Quantity per reel	Dimension P
G322	12	150	750	8

Enclosure

Package Codes

Type	Height "H"	Pin Length "L"
G322	1.6	NA

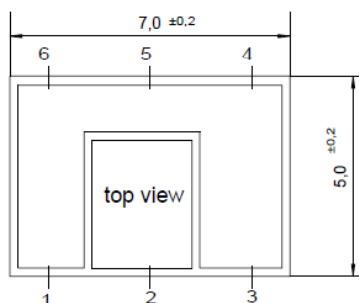

G 322

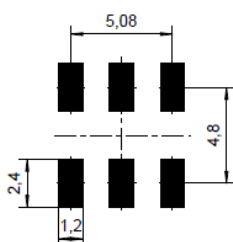
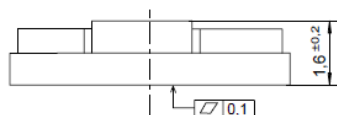

Padvorschlag
land pattern
recommendation

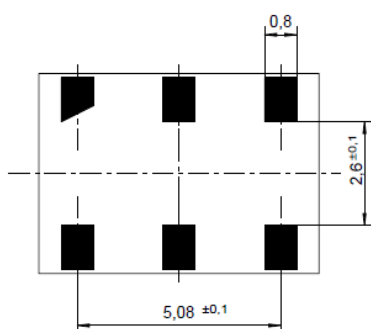

Marking

VX-706-xxxx
Frequency
● AYYWW

Pin Connections

1	Control Voltage (Vc)
2	N.C. / Enable (Option)
3	Ground
4	RF Output
5	RF Output complementary (PECL) N.C. (CMOS)
6	Supply Voltage Input (Vs)

Enable true table (optional)

	HCMOS		LVPECL	
	Pin 4	Pin 5	Pin 4	Pin 5
High	Data	N.C.	No Data	No Data
Open	Data	N.C.	Data	Compl. Data
Low	High Tristate	N.C.	Data	Compl. Data

Typical Performance

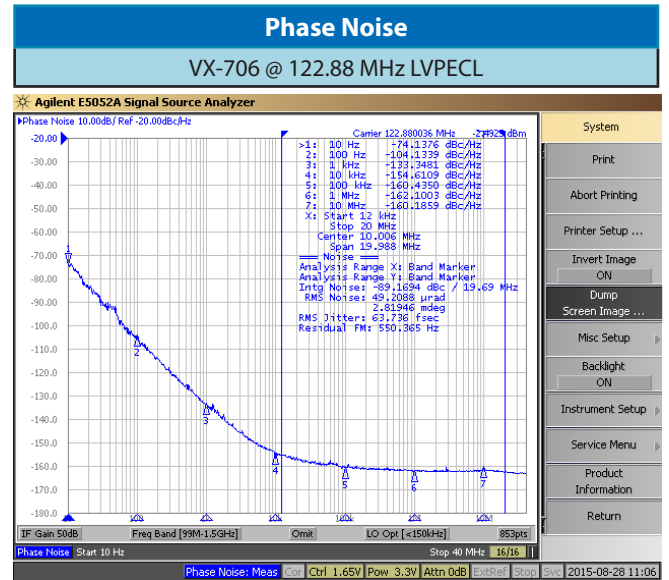
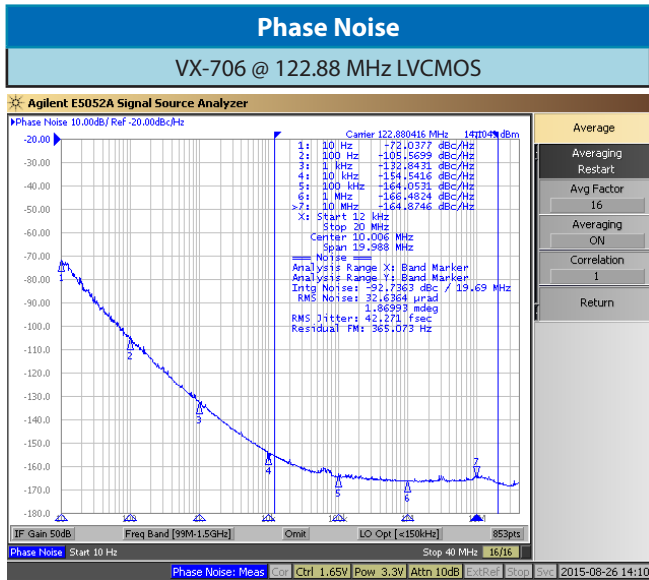

Recommended Reflow Profile

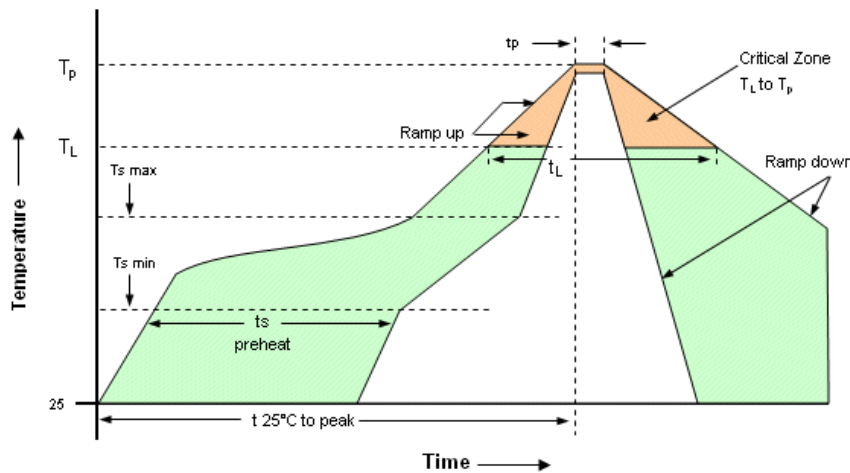

Profile Feature	Pb-Free Assembly/ Sn-Pb Assembly	Profile Feature	Pb-Free Assembly/ Sn-Pb Assembly
Average ramp-up rate (T_L to T_p)	3°C/second max.	Time 25°C to Peak Temperature	8 minutes max.
Preheat -Temperature Min T_{Smin} -Temperature Max T_{Smax} -Time (min to max) t_s	150°C 200°C 60-180 seconds	Time maintained above -Temperature (T_L) -Time (t_L)	217°C 60-150 seconds
T_{Smax} to T_L -Ramp-up Rate	3°C/second max		
Time maintained above -Temperature (T_L) -Time (t_L)	217°C 60-150 seconds	Time within 5°C of actual Peak Temperature (t_p)	20-40 seconds
Peak Temperature (T_p)	max 260°C	Ramp-down Rate	6°C/ second max

Note: All temperatures refer to topside of the package, measured on the package body surface. SMD oscillators must be on the top side of the PCB during the reflow process.

Ordering Information

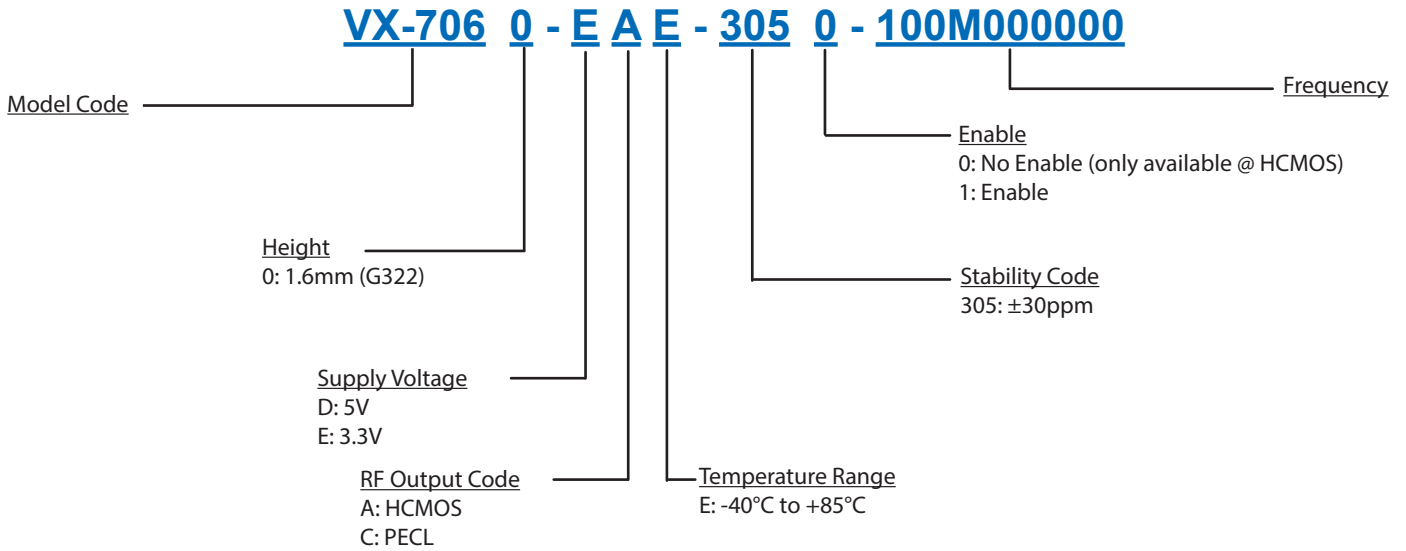

Notes:

1. Contact factory for improved stabilities or additional product options. Not all options and codes are available at all frequencies.
2. Unless other stated all values are valid after warm-up time and refer to typical conditions for supply voltage, frequency control voltage, load, temperature (25°C).
3. Phase noise degrades with increasing output frequency.
4. Subject to technical modification.
5. Contact factory for availability.

For Additional Information, Please Contact

USA:

Microsemi
267 Lowell Road, Unit 102
Hudson, NH 03051
Tel: 1.888.328.7661
Fax: 1.888.329.8328

Europe:

Vectron International GmbH
Landstrasse, D-74924
Neckarbischofsheim, Germany
Tel: +49 (0) 7268-801-0
Fax: +49 (0) 7268-801-281

Asia:

Microsemi
68 Yin Cheng Road(C), 22nd Floor
One LuJiaZui
Pudong, Shanghai 200120, China
Tel: +86 21 6194 6886
Fax: +86 21 6194 6699

Disclaimer

Microsemi reserves the right to make changes to the product(s) and or information contained herein without notice. No liability is assumed as a result of their use or application. No rights under any patent accompany the sale of any such product(s) or information.

Rev: 01/2018