

54F/74F651 • 54F/74F652 Transceivers/Registers

General Description

These devices consist of bus transceiver circuits with D-type flip-flops, and control circuitry arranged for multiplexed transmission of data directly from the input bus or from internal registers. Data on the A or B bus will be clocked into the registers as the appropriate clock pin goes to HIGH logic level. Output Enable pins (OEAB, OEBA) are provided to control the transceiver function.

Features

- Independent registers for A and B buses
- Multiplexed real-time and stored data
- Choice of non-inverting and inverting data paths
 - 'F651 inverting
 - 'F652 non-inverting
- Guaranteed 4000V minimum ESD protection

Ordering Code: See Section 11

Commercial	Military	Package Number	Package Description
74F651SPC		N24C	24-Lead (0.300" Wide) Molded Dual-In-Line
	54F651SDM (Note 2)	J24F	24-Lead (0.300" Wide) Ceramic Dual-In-Line
74F651SC (Note 1)		M24B	24-Lead (0.300" Wide) Molded Small Outline, JEDEC
	54F651FM (Note 2)	W24C	24-Lead Cerpack
	54F651LM (Note 2)	E28A	24-Lead Ceramic Leadless Chip Carrier, Type C
74F652SPC		N24C	24-Lead (0.300" Wide) Molded Dual-In-Line
	54F652SDM (Note 2)	J24F	24-Lead (0.300" Wide) Ceramic Dual-In-Line
74F652SC (Note 1)		M24B	24-Lead (0.300" Wide) Molded Small Outline, JEDEC
	54F652FM (Note 2)	W24C	24-Lead Cerpack
	54F652LM (Note 2)	E28A	24-Lead Ceramic Leadless Chip Carrier, Type C

Note 1: Devices also available in 13" reel. Use suffix = SCX

Note 2: Military grade device with environmental and burn-in processing. Use suffix = DMCB, FMOB and LMOB

Connection Diagrams

**Pin Assignment
DIP, SOIC and Flatpak**

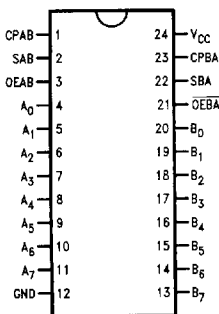

**Pin Assignment
for LCC**

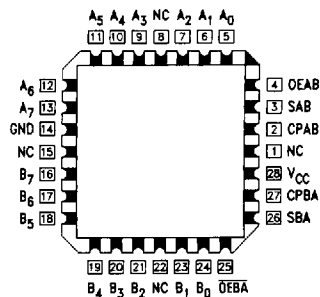

TL/F/9581-3

TL/F/9581-4

Logic Symbols

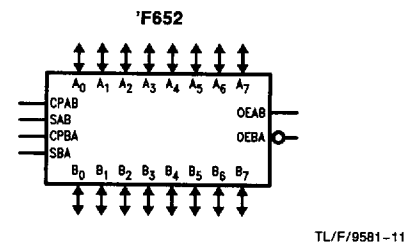
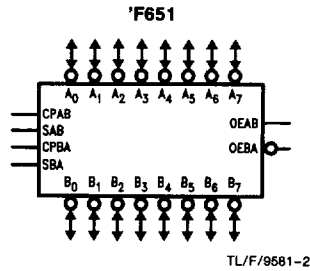
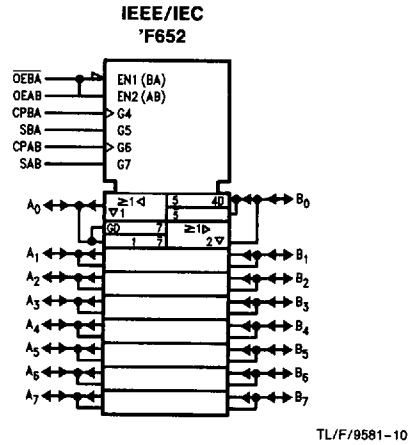
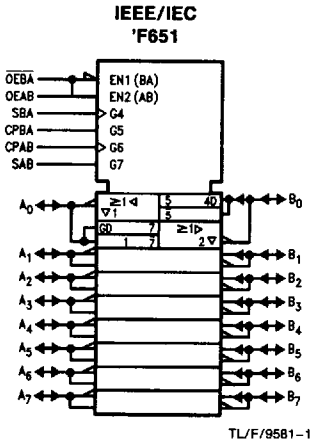

Unit Loading/Fan Out: See Section 2 for U.L. Definitions

Pin Names	Description	54F/74F	
		U.L. HIGH/LOW	Input I_{IH}/I_{IL} Output I_{OH}/I_{OL}
A ₀ -A ₇ , B ₀ -B ₇	A and B Inputs/ TRI-STATE® Outputs	1.0/1.0 600/106.6 (80)	20 μ A/ -0.6 mA -12 mA/64 mA (48 mA)
CPAB, CPBA	Clock Inputs	1.0/1.0	20 μ A/ -0.6 mA
SAB, SBA	Select Inputs	1.0/1.0	20 μ A/ -0.6 mA
OEAB, OEBA	Output Enable Inputs	1.0/1.0	20 μ A/ -0.6 mA

Logic Diagrams

'F652

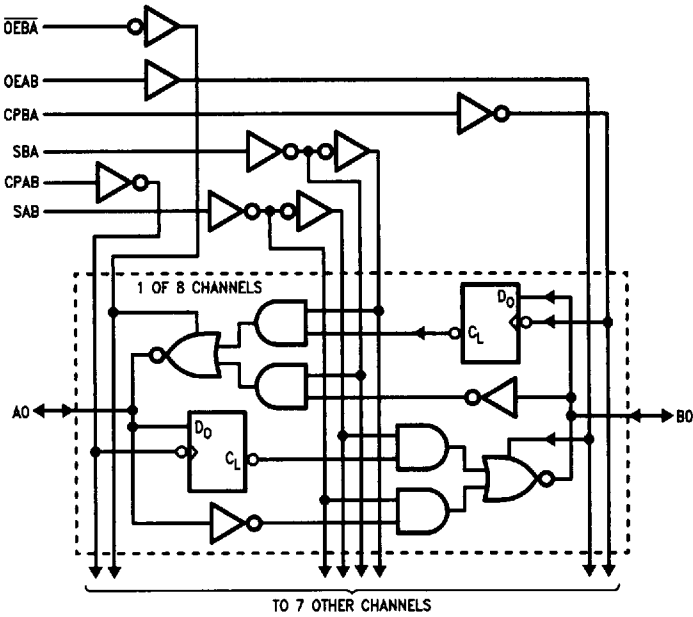

TL/F/9581-5

Please note that this diagram is provided only for the understanding of logic operations and should not be used to estimate propagation delays.

'F651

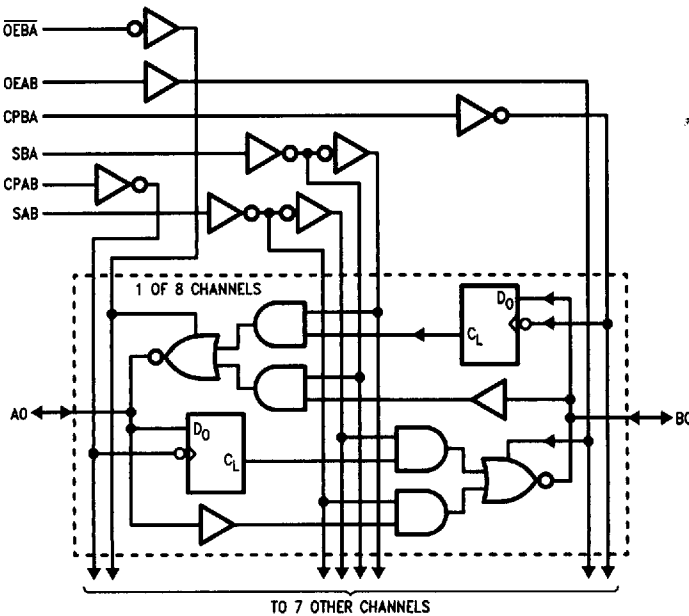

TL/F/9581-12

Please note that this diagram is provided only for the understanding of logic operations and should not be used to estimate propagation delays.

Functional Description

In the transceiver mode, data present at the HIGH impedance port may be stored in either the A or B register or both. The select (SAB, SBA) controls can multiplex stored and real-time.

The examples in *Figure 1* demonstrate the four fundamental bus-management functions that can be performed with the Octal bus transceivers and receivers.

Data on the A or B data bus, or both can be stored in the internal D flip-flop by LOW to HIGH transitions at the appro-

priate Clock Inputs (CPAB, CPBA) regardless of the Select or Output Enable Inputs. When SAB and SBA are in the real time transfer mode, it is also possible to store data without using the internal D flip-flops by simultaneously enabling OEAB and OEBA. In this configuration each Output reinforces its input. Thus when all other data sources to the two sets of bus lines are in a HIGH impedance state, each set of bus lines will remain at its last state.

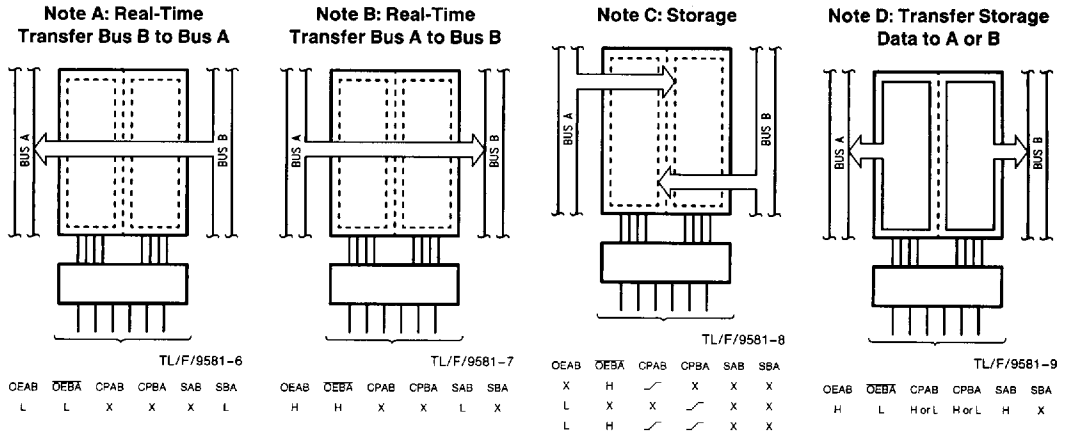

FIGURE 1

Inputs						Inputs/Outputs (Note 1)		Operating Mode
OEAB	OEBA	CPAB	CPBA	SAB	SBA	A ₀ thru A ₇	B ₀ thru B ₇	
L	H	H or L	H or L	X	X	Input	Input	Isolation
L	H	↗	↘	X	X			Store A and B Data
X	H	↗	H or L	X	X	Input	Not Specified	Store A, Hold B
H	H	↗	↘	X	X	Input	Output	Store A in Both Registers
L	X	H or L	↗	X	X	Not Specified	Input	Hold A, Store B
L	L	↗	↘	X	X	Output	Input	Store B in Both Registers
L	L	X	X	X	L			Real-Time B Data to A Bus
L	L	X	H or L	X	H	Input	Output	Store B Data to A Bus
H	H	X	X	L	X			Real-Time A Data to B Bus
H	H	H or L	X	H	X	Output	Output	Stored A Data to B Bus
H	L	H or L	H or L	H	H			Stored A Data to B Bus and Stored B Data to A Bus

H = HIGH Voltage Level
 L = LOW Voltage Level
 X = Immaterial
 ↗ = LOW to HIGH Clock Transition

Note 1: The data output functions may be enabled or disabled by various signals at OEAB or OEBA inputs. Data input functions are always enabled, i.e., data at the bus pins will be stored on every LOW to HIGH transition on the clock inputs.

Absolute Maximum Ratings (Note 1)

If Military/Aerospace specified devices are required, please contact the National Semiconductor Sales Office/Distributors for availability and specifications.

Storage Temperature	-65°C to +150°C
Ambient Temperature under Bias	-55°C to +125°C
Junction Temperature under Bias	-55°C to +175°C
Plastic	-55°C to +150°C
V _{CC} Pin Potential to Ground Pin	-0.5V to +7.0V
Input Voltage (Note 2)	-0.5V to +7.0V
Input Current (Note 2)	-30 mA to +5.0 mA

Note 1: Absolute maximum ratings are values beyond which the device may be damaged or have its useful life impaired. Functional operation under these conditions is not implied.

Note 2: Either voltage limit or current limit is sufficient to protect inputs.

Voltage Applied to Output in HIGH State (with V _{CC} = 0V)	-0.5V to V _{CC}
Standard Output	-0.5V to +5.5V
TRI-STATE Output	-0.5V to +5.5V
Current Applied to Output in LOW State (Max)	twice the rated I _{OL} (mA)
ESD Last Passing Voltage (Min)	4000V

Recommended Operating Conditions

Free Air Ambient Temperature	-55°C to +125°C
Military	-55°C to +125°C
Commercial	0°C to +70°C
Supply Voltage	+4.5V to +5.5V
Military	+4.5V to +5.5V
Commercial	+4.5V to +5.5V

DC Electrical Characteristics

Symbol	Parameter	54F/74F			Units	V _{CC}	Conditions
		Min	Typ	Max			
V _{IH}	Input HIGH Voltage	2.0			V		Recognized as a HIGH Signal
V _{IL}	Input LOW Voltage			0.8	V		Recognized as a LOW Signal
V _{CD}	Input Clamp Diode Voltage			-1.2	V	Min	I _{IN} = -18 mA (Non I/O Pins)
V _{OH}	Output HIGH Voltage	54F 10% V _{CC} 74F 10% V _{CC}	2.0	2.0	V	Min	I _{OH} = -12 mA (A _n , B _n) I _{OH} = -15 mA (A _n , B _n)
V _{OL}	Output LOW Voltage	54F 10% V _{CC} 74F 10% V _{CC}		0.55 0.55	V	Min	I _{OL} = 48 mA (A _n , B _n) I _{OL} = 64 mA (A _n , B _n)
I _{IH}	Input HIGH Current	54F 74F		20.0 5.0	μA	Max	V _{IN} = 2.7V (Non I/O Pins)
I _{BVI}	Input HIGH Current Breakdown Test	54F 74F		100 7.0	μA	Max	V _{IN} = 7.0V
I _{BVIT}	Input HIGH Current Breakdown (I/O)	54F 74F		1.0 0.5	mA	Max	V _{IN} = 5.5V (A _n , B _n)
I _{CEX}	Output HIGH Leakage Current	54F 74F		250 50	μA	Max	V _{OUT} = V _{CC}
V _{ID}	Input Leakage Test	74F	4.75		V	0.0	I _{ID} = 1.9 μA All Other Pins Grounded
I _{OD}	Output Leakage Circuit Current	74F		3.75	μA	0.0	V _{I_{OD}} = 150 mV All Other Pins Grounded
I _{IL}	Input LOW Current			-0.6	mA	Max	V _{IN} = 0.5V (Non I/O Pins)
I _{IH} + I _{OZH}	Output Leakage Current			70	μA	Max	V _{OUT} = 2.7V (A _n , B _n)
I _{IL} + I _{OZL}	Output Leakage Current			-650	μA	Max	V _{OUT} = 0.5V (A _n , B _n)
I _{OS}	Output Short-Circuit Current		-100	-225	mA	Max	V _{OUT} = 0V
I _{ZZ}	Bus Drainage Test			500	μA	0.0V	V _{OUT} = 5.25V
I _{CCH}	Power Supply Current		105	135	mA	Max	V _O = HIGH
I _{CCL}	Power Supply Current		118	150	mA	Max	V _O = LOW
I _{CCZ}	Power Supply Current		115	150	mA	Max	V _O = HIGH Z

AC Electrical Characteristics: See Section 2 for Waveforms and Load Configurations

Symbol	Parameter	74F		54F		74F		Units	Fig. No.
		$T_A = +25^\circ\text{C}$ $V_{CC} = +5.0\text{V}$ $C_L = 50\text{ pF}$		$T_A, V_{CC} = \text{Mil}$ $C_L = 50\text{ pF}$		$T_A, V_{CC} = \text{Com}$ $C_L = 50\text{ pF}$			
		Min	Max	Min	Max	Min	Max		
f_{max}	Max. Clock Frequency	90		75		90		MHz	2-1
t_{PLH} t_{PHL}	Propagation Delay Clock to Bus	2.0	7.0	2.0	8.5	2.0	8.0	ns	2-3
t_{PLH} t_{PHL}	Propagation Delay Bus to Bus ('F651)	1.0	7.5	1.0	8.0	1.0	8.0		
t_{PLH} t_{PHL}	Propagation Delay Bus to Bus ('F652)	1.0	7.0	1.0	8.0	1.0	7.5	ns	2-3
t_{PLH} t_{PHL}	Propagation Delay SBA or SAB to A or B	2.0	8.5	2.0	11.0	2.0	9.5		
t_{PLH} t_{PHL}		2.0	8.0	2.0	10.0	2.0	9.0	ns	2-3

AC Operating Requirements: See Section 2 for Waveforms

Symbol	Parameter	74F		54F		74F		Units	Fig. No.
		$T_A = +25^\circ\text{C}$ $V_{CC} = +5.0\text{V}$		$T_A, V_{CC} = \text{Mil}$		$T_A, V_{CC} = \text{Com}$			
		Min	Max	Min	Max	Min	Max		
t_{PZH} t_{PZL}	Enable Time *OEBA to A	2.0	9.5	2.0	10.0	2.0	10.0	ns	2-5
t_{PHZ} t_{PLZ}	Disable Time *OEBA to A	1.0	7.5	1.0	9.0	1.0	8.0		
t_{PZH} t_{PZL}	Enable Time OEAB to B	2.0	9.5	2.0	10.0	2.0	10.0		
t_{PHZ} t_{PLZ}	Disable Time OEAB to B	2.0	9.0	1.0	9.0	2.0	10.0	ns	2-5
$t_{\text{S}}(\text{H})$ $t_{\text{S}}(\text{L})$	Setup Time, HIGH or LOW, Bus to Clock	5.0		5.0		5.0		ns	2-6
$t_{\text{H}}(\text{H})$ $t_{\text{H}}(\text{L})$	Hold Time, HIGH or LOW, Bus to Clock	2.0		2.5		2.0			
$t_{\text{W}}(\text{H})$ $t_{\text{W}}(\text{L})$	Clock Pulse Width HIGH or LOW	5.0		5.0		5.0		ns	2-4
		5.0		5.0		5.0			