

CFPT-9300 SMD TCVCXO

ISSUE 6; 12 AUGUST 2009 - RoHS 2002/95/EC

Description

- Surface mount temperature compensated voltage controlled crystal oscillators for medium to high volume applications where small size and high performance are prerequisites. Manufactured for us by Rakon utilising their Pluto™ ASIC technology and capable of sub 0.3ppm performance over an extended temperature range. Its ability to function down to a supply voltage of 2.4V and low power consumption makes it particularly suitable for mobile applications

Package Outline

- 5.0 x 3.2mm
- Optional low profile, nom dimensions 5.0 x 3.2 x 1.4mm

Standard Frequencies

- 10 (HCMOS only), 12.688375, 12.8, 13, 14.4, 16, 16.367, 16.384, 16.8, 19.2, 19.44, 20, 24, 24.5535, 26, 32.768, 33.6, 36, 38.88 and 40 MHz

Frequency Range

- 1.5 to 52 MHz

Output Compatibility & Load (standard)

- HCMOS 15pF max
- Clipped sinewave 10kΩ // 10pF, DC-coupled

Output Compatibility & Load (options)

- ACMOS 50pF max
- Sinewave 10kΩ // 10pF, DC-coupled

Frequency Stability

- Temperature: see table
- Supply Voltage Variation, ±5%
HCMOS, < 20MHz ±0.1ppm typ.
HCMOS, 20-35MHz ±0.3ppm typ.
HCMOS, 35-52MHz ±0.5ppm typ.
Clipped Sinewave ±0.05ppm typ.
- Load Coefficient,
15pF ±5pF (HCMOS)
< 20 MHz ±0.2ppm typ
20-35 MHz ±0.5ppm typ
35-52 MHz ±0.8ppm typ
10kΩ // 10pF ± 10% ±0.05ppm typ

Supply Voltage

- Standard 3.0V, 3.3V (see table)
- Supply voltages in the range 2.4 to 6.0V available to order, please contact our sales office

Supply Current (typically)

- HCMOS
 $1 + \text{Frequency(MHz)} * \text{Supply(V)} * \{\text{Load(pF)} + 15\} * 10^{-3} \text{mA}$
e.g. 20MHz, 3.3V, 15pF ≈ 3mA
- Clipped Sinewave
 $1 + \text{Frequency(MHz)} * 1.2 * \{\text{Load(pF)} + 30\} * 10^{-3} \text{mA}$
e.g. 20MHz, 10pF ≈ 2mA

Ageing

- ±1ppm maximum in first year, frequency ≤20MHz
- ±2ppm maximum in first year, frequency >20MHz
- ±3ppm maximum for 10 years (including the first year), frequency ≤20MHz
- ±5ppm maximum for 10 years (including the first year), frequency >20MHz
- ±1ppm maximum after reflow

Frequency Adjustment - option A (standard)

Ageing adjustment by means of external Control Voltage applied to pad 1

- Range (frequency ≤ 20MHz) ≥ ±5ppm
- Range (frequency > 20MHz) ≥ ±7ppm
- Linearity ≤2%
- Slope Positive
- Input resistance ≥ 100kΩ
- Modulation bandwidth ≥ 2kHz
- Standard control voltage range 1.5V±1V

Frequency Adjustment - option B

No frequency adjustment

- Initial calibration ≤ ±1.0ppm

Storage Temperature Range

- 55 to +125°C

Environmental

- Vibration: IEC 60068-2-6, test Fc, procedure B4: 10-60Hz 1.5 mm displacement, 60-2000Hz at 20gn, 4 hours in each of three mutually perpendicular planes at 1 octave per minute.
- Shock: IEC 60068-2-27, test Ea: 1500gn acceleration for 0.5ms duration, half-sine pulse, 3 shocks in each direction along three mutually perpendicular planes.

Marking Includes

- 'R' (Manufacturers ID) + Manufacturing identifier (X XX) + Pad 1 / Static sensitivity identifier (Triangle) + Abbreviated Part Number + Date Code

Packaging

- Bulk or Tape & Reel
- Tape & Reel in accordance with EIA-481-D

Minimum Order Information Required

- Frequency + Model Number + Frequency Stability vs Operating Temperature Range Code + Frequency Adjustment Code

Electrical Specification - maximum limiting values

Frequency Range	Supply Voltage	Output Waveform	Output Levels	Rise Time (tr)	Fall Time(tf)	Duty Cycle	Model Number
1.5 to 52.0MHz	3.3V ±10%*	HCMOS 15pF	VoH ≥ 90% Vs VoL ≤ 10% Vs	8ns	8ns	45/55%	CFPT-9301
12.0 to 52.0MHz	3.0V ±10%*	Clipped Sine 10kΩ//10pF	V pk-pk ≥0.8V	–	–	–	CFPT-9302

*Parts will operate correctly with ±10% supply voltage variation but supply coefficient is measured with ±5% variation

Frequency Stabilities over Operating Temperature Range

Operating Temperature Ranges	Frequency Stabilities v Operating Temperature Range				
	±0.2ppm	±0.3ppm	±0.5ppm	±1.0ppm	±2.0ppm
-20 to 70°C	Code MS**	Code AS**	Code ES	Code FS	Code GS
-40 to 85°C	–	Code AX**	Code EX**	Code FX	Code GX

Ordering Example 14.4MHz CFPT-9301 EX A
 Frequency _____
 Model No. _____
 Frequency Stability vs Operating Temperature Code _____
 Frequency Adjustment Code _____

**Codes may not be available for all frequencies

Outline (mm)

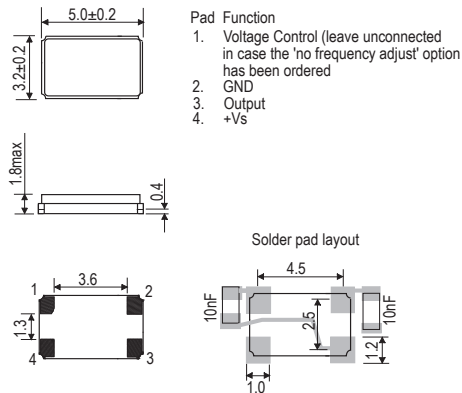

Low profile option: 1.6mm max height

Output Waveform

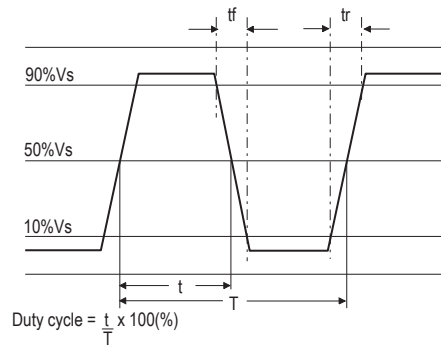

Test Circuit

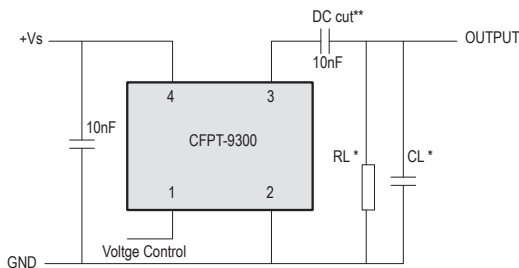

* Load 15pF (HCMOS) or 10kΩ // 10pF (clipped sinewave), inclusive of probe and jig capacitance

** DC cut capacitor required for AC coupled clipped sinewave

Typical Phase Noise at 14.4MHz

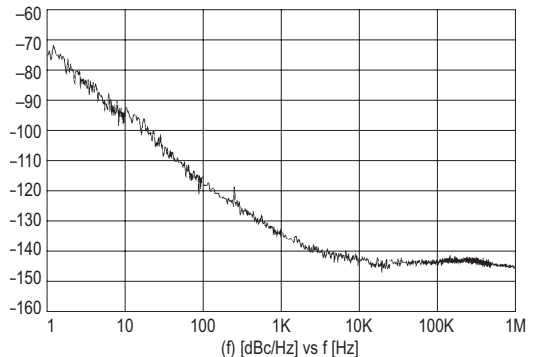

TCXOs