

COS/MOS INTEGRATED CIRCUIT

4532B



8-BIT PRIORITY ENCODER

- CONVERTS FROM 1 OF 8 TO BINARY
- PROVIDES CASCADING FEATURE TO HANDLE ANY NUMBER OF INPUTS
- GROUP SELECT INDICATES ONE OR MORE PRIORITY INPUTS
- QUIESCENT CURRENT SPECIFIED TO 20V FOR HCC DEVICE
- STANDARDIZED SYMMETRICAL OUTPUT CHARACTERISTICS
- 5V, 10V, AND 15V PARAMETRIC RATINGS
- INPUT CURRENT OF 100 nA AT 18V AND 25°C FOR HCC DEVICE
- 100% TESTED FOR QUIESCENT CURRENT
- MEETS ALL REQUIREMENTS OF JEDEC TENTATIVE STANDARD No. 13A, "STANDARD SPECIFICATIONS FOR DESCRIPTION OF "B" SERIES CMOS DEVICES"

The **HCC 4532B** (extended temperature range) and **HCF 4532B** (intermediate temperature range) are monolithic integrated circuit, available in 16-lead dual in-line plastic or ceramic package, ceramic flat package and plastic micropackage.

The **HCC/HCF 4532** consists of combinational logic that encodes the highest priority input (D7-D0) to a 3-bit binary code. The eight inputs, D7 through D0, each have an assigned priority. D7 is the highest priority and D0 is the lowest. The priority encoder is inhibited when the chip-enable input E_1 is low. When E_1 is high, the binary representation of the highest-priority input appears on output lines Q2-Q0, and the group select line GS is high to indicate that priority inputs are present. The enable-out (E_O) is high when no priority inputs are present. If any one input is high, E_O is low and all cascaded lower-order stages are disabled.

ABSOLUTE MAXIMUM RATINGS

V_{DD}^*	Supply voltage: HCC types HCF types	-0.5 to 20	V
V_i	Input voltage	-0.5 to 18	V
I_i	DC input current (any one input)	-0.5 to $V_{DD} + 0.5$	V
P_{tot}	Total power dissipation (per package)	± 10	mA
	Dissipation per output transistor	200	mW
	for T_{op} = full package-temperature range	100	mW
T_{op}	Operating temperature: HCC types HCF types	-55 to 125	°C
		-40 to 85	°C
T_{stg}	Storage temperature	-65 to 150	°C

* All voltage values are referred to V_{SS} pin voltage

ORDERING NUMBERS:

- HCC 4532 BD for dual in-line ceramic package
- HCC 4532 BF for dual in-line ceramic package, frit seal
- HCC 4532 BK for ceramic flat package
- HCF 4532 BE for dual in-line plastic package
- HCF 4532 BF for dual in-line ceramic package, frit seal
- HCF 4532 BM for plastic micropackage

HCC/DCF 4532 B

MECHANICAL DATA (dimensions in mm)

Dual in-line ceramic package for HCC 4532 BD

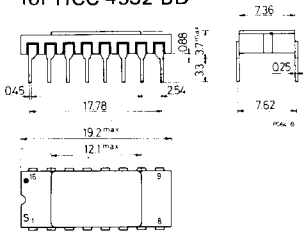

Dual in-line ceramic package for HCC/DCF 4532 BF

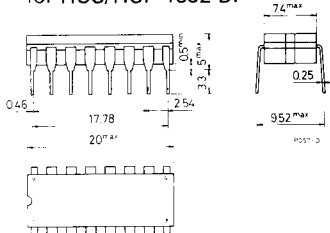

Dual in-line plastic package for HCF 4532 BE

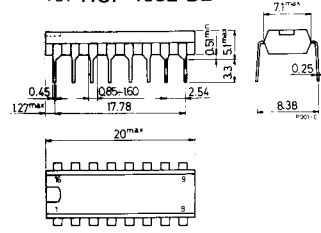

Ceramic flat package for HCC 4532 BK

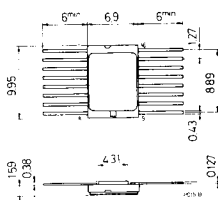

Plastic micropackage for HCF 4532 BM

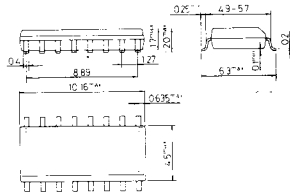

CONNECTION DIAGRAM

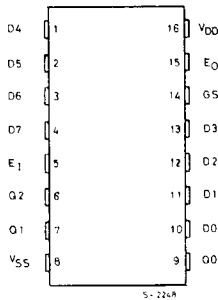

FUNCTIONAL DIAGRAM

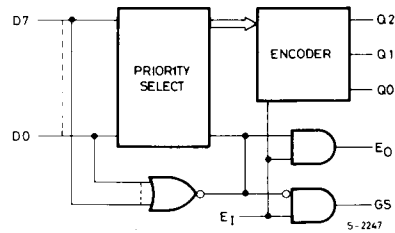

RECOMMENDED OPERATING CONDITIONS

V_{DD}	Supply voltage: HCC types HCF types	3 to 18 3 to 15	V V
V_I	Input voltage	0 to V_{DD}	V
T_{op}	Operating temperature: HCC types HCF types	-55 to 125 -40 to 85	°C °C

LOGIC DIAGRAM

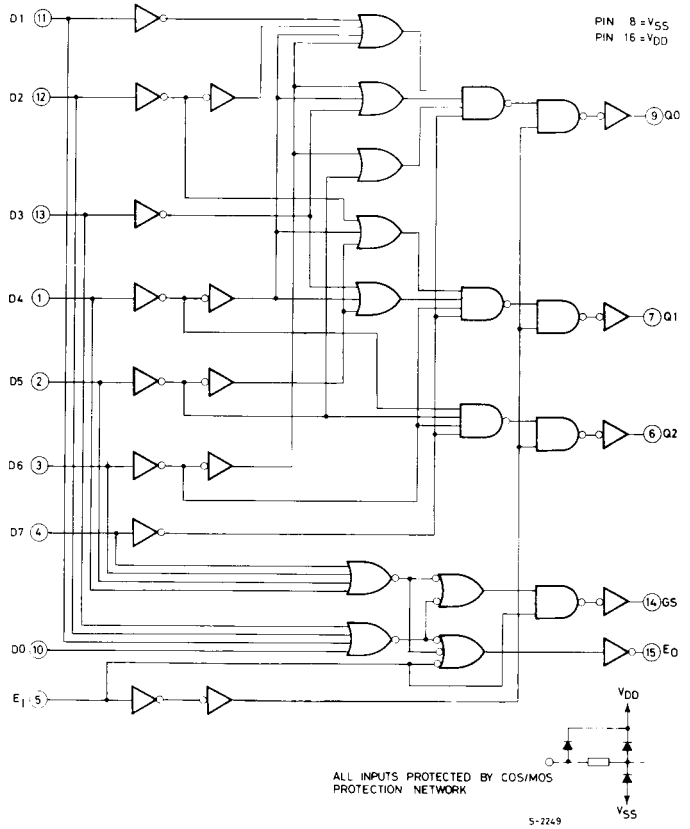

TRUTH TABLE

Input									Output				
E1	D7	D6	D5	D4	D3	D2	D1	D0	GS	Q2	Q1	Q0	E0
0	X	X	X	X	X	X	X	X	0	0	0	0	0
1	0	0	0	0	0	0	0	0	0	0	0	0	1
1	1	X	X	X	X	X	X	X	1	1	1	1	0
1	0	1	X	X	X	X	X	X	1	1	1	0	0
1	0	0	1	X	X	X	X	X	1	1	0	1	0
1	0	0	0	1	X	X	X	X	1	1	0	0	0
1	0	0	0	0	1	X	X	X	1	0	1	1	0
1	0	0	0	0	0	1	X	X	1	0	1	0	0
1	0	0	0	0	0	0	1	X	1	0	0	1	0
1	0	0	0	0	0	0	0	1	1	0	0	0	0

X - Don't Care

Logic 1 ≡ High

Logic 0 ≡ Low

HCC/HCF 4532B

Handwritten notes:
 4532B
 HCC-HCF
 4532B

STATIC ELECTRICAL CHARACTERISTICS (over recommended operating conditions)

Parameter		Test conditions				Values						Unit	
		V _I (V)	V _O (V)	I _O (μ A)	V _{DD} (V)	T _{Low} *		25°C			T _{High} *		
						Min.	Max.	Min.	Typ.	Max.	Min.		Max.
I _L	Quiescent current	HCC types	0/ 5			5		5		0.04	5		150
			0/10			10		10		0.04	10		300
			0/15			15		20		0.04	20		600
			0/20			20		100		0.08	100		3000
		HCF types	0/ 5			5		20		0.04	20		150
			0/10			10		40		0.04	40		300
								0.04	80		600		
V _{OH}	Output high voltage	0/ 5		< 1	5	4.95		4.95			4.95		
		0/10		< 1	10	9.95		9.95			9.95		
		0/15		< 1	15	14.95		14.95			14.95		
V _{OL}	Output low voltage	5/0		< 1	5		0.05			0.05		0.05	
		10/0		< 1	10		0.05			0.05		0.05	
		15/0		< 1	15		0.05			0.05		0.05	
V _{IH}	Input high voltage		0.5/4.5	< 1	5	3.5		3.5			3.5		
			1/9	< 1	10	7		7			7		
			1.5/13.5	< 1	15	11		11			11		
V _{IL}	Input low voltage		4.5/0.5	< 1	5		1.5			1.5		1.5	
			9/1	< 1	10		3			3		3	
			13.5/1.5	< 1	15		4			4		4	
I _{OH}	Output drive current	HCC types	0/ 5	2.5		5	-2		-1.6	-3.2		-1.15	
			0/ 5	4.6		5	-0.64		-0.51	-1		-0.36	
			0/10	9.5		10	-1.6		-1.3	-2.6		-0.9	
			0/15	13.5		15	-4.2		-3.4	-6.8		-2.4	
		HCF types	0/ 5	2.5		5	-1.53		-1.36	-3.2		-1.1	
			0/ 5	4.6		5	-0.52		-0.44	-1		-0.36	
I _{OL}	Output sink current	HCC types	0/ 5	0.4		5	0.64		0.51	1		0.36	
			0/10	0.5		10	1.6		1.3	2.6		0.9	
			0/15	1.5		15	4.2		3.4	6.8		2.4	
		HCF types	0/ 5	0.4		5	0.52		0.44	1		0.36	
			0/10	0.5		10	1.3		1.1	2.6		0.9	
			0/15	1.5		15	3.6		3.0	6.8		2.4	
I _{IH} , I _{IL}	Input leakage current	HCC types	0/18	Any input	18		± 0.1		$\pm 10^{-5}$	± 0.1		± 1	
		HCF types	0/15		15		± 0.3		$\pm 10^{-5}$	± 0.3		± 1	
C _I	Input capacitance			Any input					5	7.5		pF	

* T_{Low} = - 55°C for HCC device; -40°C for HCF device.

* T_{High} = +125°C for HCC device; +85°C for HCF device.

The Noise Margin for both "1" and "0" level is: 1V min. with V_{DD} = 5V
 2V min. with V_{DD} = 10V
 2.5V min. with V_{DD} = 15V



DYNAMIC ELECTRICAL CHARACTERISTICS ($T_{amb} = 25^{\circ}C$, $C_L = 50$ pF, $R_L = 200$ k Ω , typical temperature coefficient for all V_{DD} values is 0,3%/ $^{\circ}C$, all input rise and fall times = 20 ns)

Parameter	Test conditions	Values			Unit	
		V_{DD} (V)	Min.	Typ.		Max.
t_{PLH} , t_{PHL} Propagation delay time (E_I to E_O , E_I to GS)		5		110	220	ns
		10		55	110	
		15		45	85	
t_{PLH} , t_{PHL} Propagation delay time (E_I to Q_M , D_n to GS)		5		170	340	ns
		10		85	170	
		15		65	125	
t_{PLH} , t_{PHL} Propagation delay time (D_n to Q_M)		5		220	440	ns
		10		110	220	
		15		85	160	
t_{TLH} , t_{THL} Transition time		5		100	200	ns
		10		50	100	
		15		40	80	

TEST CIRCUITS

Input leakage current

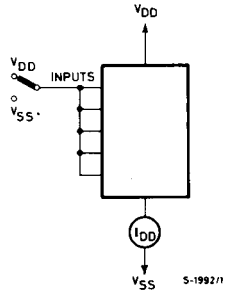

Noise immunity

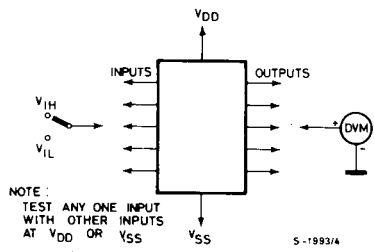

Quiescent device current

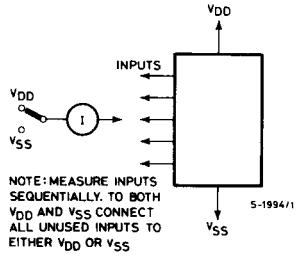

Dynamic power dissipation

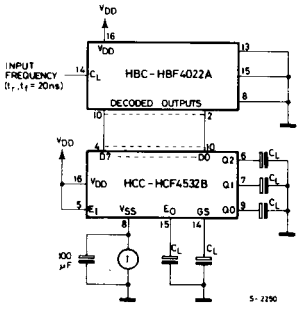

HCC/HC_F 4532B

Minimum output low (sink) current characteristics

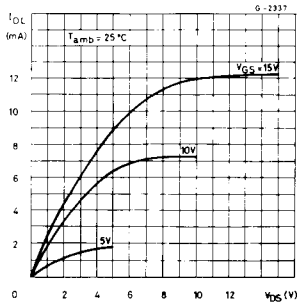

Typical output high (source) current characteristics

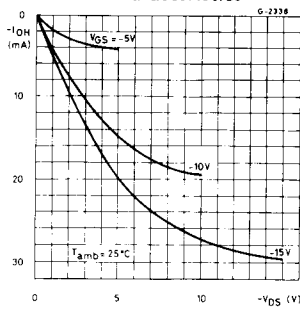

Minimum output high (source) current characteristics

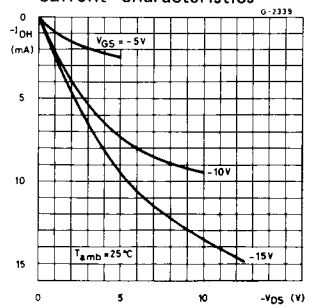

Typical output low (sink) current characteristics

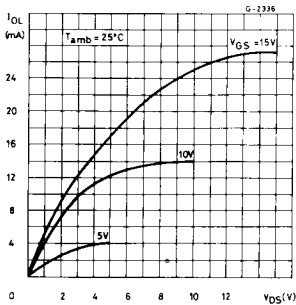

Typical propagation delay (D_n to Q_m) vs. supply voltage

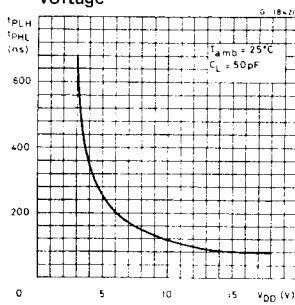

Typical propagation delay (E_1 to GS , E_1 to E_O) vs. load capacitance

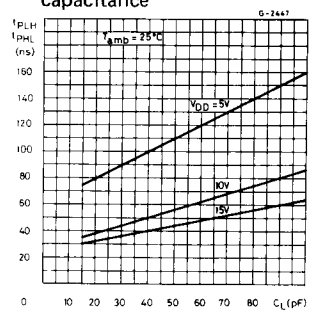

Typical propagation delay (D_n to Q_m) vs. load capacitance

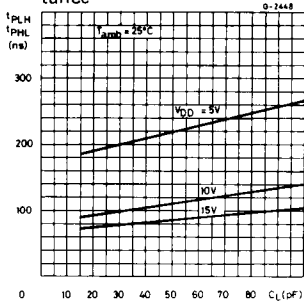

Typical transition time vs. load capacitance

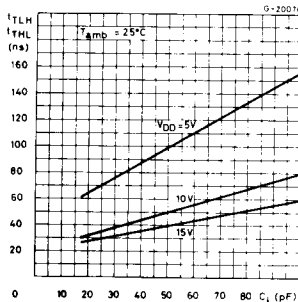

Typical dynamic power dissipation vs. frequency

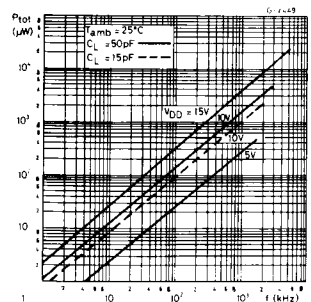

APPLICATIONS

16-level priority encoder

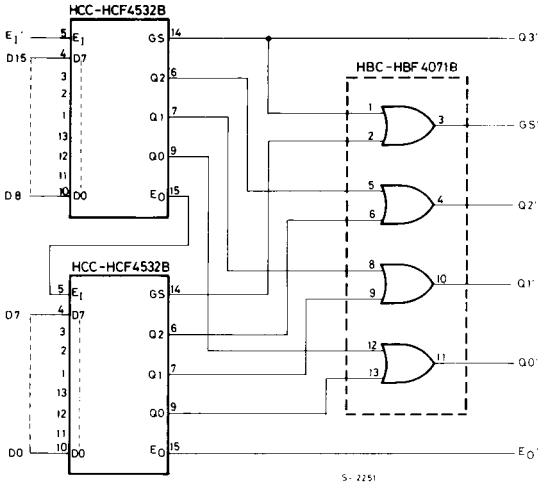

0-to-9 keyboard encoder

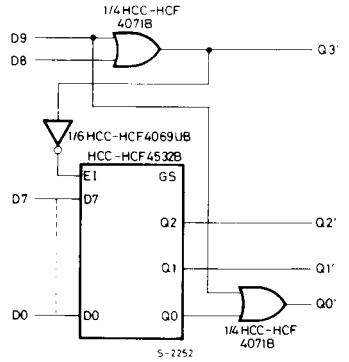

TRUTH TABLE

Input										Output				
D9	D8	D7	D6	D5	D4	D3	D2	D1	D0	GS	Q3'	Q2'	Q1'	Q0'
1	X	X	X	X	X	X	X	X	X	0	1	0	0	1
0	1	X	X	X	X	X	X	X	X	0	1	0	0	0
0	0	1	X	X	X	X	X	X	X	1	0	1	1	1
0	0	0	1	X	X	X	X	X	X	1	0	1	1	0
0	0	0	0	1	X	X	X	X	X	1	0	1	0	1
0	0	0	0	0	1	X	X	X	X	1	0	1	0	0
0	0	0	0	0	0	1	X	X	X	1	0	0	1	1
0	0	0	0	0	0	0	1	X	X	1	0	0	1	0
0	0	0	0	0	0	0	0	1	X	1	0	0	0	1
0	0	0	0	0	0	0	0	0	1	1	0	0	0	0

X = Don't Care

Logic 1 ≡ High

Logic 0 ≡ Low

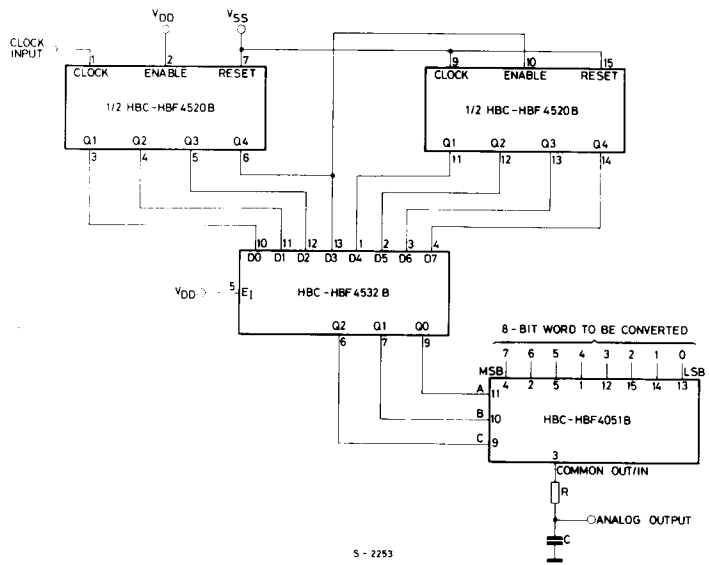
APPLICATIONS (continued)
DIGITAL TO ANALOG CONVERSION

S - 2253