



SANYO Semiconductors

DATA SHEET

LB8683CL

Monolithic Digital IC
For Cell Phone Cameras
**1.5-channel Bidirectional
Motor Driver IC**

Overview

The LB8683CL is a low-voltage, low-saturation forward/reverse motor driver IC with built-in 1.5-channel bridge. Its compact, low-profile package makes it ideal for use in cell phone cameras.

Using direct microcontroller drive, and the control of the shutter and the voice coil motor for the iris drive, etc..

Features

- Low voltage operation(2.2V min)
- Ultraminiature ECSP2828-10 package (2.8mm×2.8mm×0.8mm)

Functions

- Constant current control ($I_{OUT} = 100\text{mA}$ when $R_F = 2\Omega$)
- Built-in thermal protection circuit
- Built-in reference voltage circuit (0.2V typical)
- Built-in spark killer diodes

Specifications**Absolute Maximum Ratings** at $T_a = 25^\circ\text{C}$

Parameter	Symbol	Conditions	Ratings	Unit
Maximum supply voltage	$V_{CC\text{ max}}$		-0.3 to +0.8	V
Output voltage	$V_{OUT\text{ max}}$	OUT1, OUT2, OUT3	$V_{CC} + V_{SF}$	V
Input voltage	$V_{IN\text{ max}}$	IN1, IN2, IN3	-0.3 to +0.8	V
GND pin source current	I_{GND}	Per channel	400	mA
Allowable power dissipation	$P_d\text{ max}$	When mounted on a circuit board*	450	mW
Operating temperature	T_{opr}		-30 to +85	$^\circ\text{C}$
Storage temperature	T_{stg}		-40 to +150	$^\circ\text{C}$

* Specified circuit board: 20.0mm×10.0mm×0.8mm, paper phenol board.

■ Any and all SANYO Semiconductor Co.,Ltd. products described or contained herein are, with regard to "standard application", intended for the use as general electronics equipment (home appliances, AV equipment, communication device, office equipment, industrial equipment etc.). The products mentioned herein shall not be intended for use for any "special application" (medical equipment whose purpose is to sustain life, aerospace instrument, nuclear control device, burning appliances, transportation machine, traffic signal system, safety equipment etc.) that shall require extremely high level of reliability and can directly threaten human lives in case of failure or malfunction of the product or may cause harm to human bodies, nor shall they grant any guarantee thereof. If you should intend to use our products for applications outside the standard applications of our customer who is considering such use and/or outside the scope of our intended standard applications, please consult with us prior to the intended use. If there is no consultation or inquiry before the intended use, our customer shall be solely responsible for the use.

■ Specifications of any and all SANYO Semiconductor Co.,Ltd. products described or contained herein stipulate the performance, characteristics, and functions of the described products in the independent state, and are not guarantees of the performance, characteristics, and functions of the described products as mounted in the customer's products or equipment. To verify symptoms and states that cannot be evaluated in an independent device, the customer should always evaluate and test devices mounted in the customer's products or equipment.

SANYO Semiconductor Co., Ltd.

TOKYO OFFICE Tokyo Bldg., 1-10, 1 Chome, Ueno, Taito-ku, TOKYO, 110-8534 JAPAN

Allowable Operating Ranges at $T_a = 25^\circ\text{C}$

Parameter	Symbol	Conditions	Ratings	Unit
Supply voltage	V_{CC}		2.2 to 7.5	V
High-level input voltage	V_{IH}	IN1, IN2, IN3	1.5 to 7.5	V
Low-level input voltage	V_{IL}		-0.3 to +0.5	V

Electrical Characteristics at $T_a = 25^\circ\text{C}$, $V_{CC} = 3.3\text{V}$

Parameter	Symbol	Conditions	Ratings			Unit
			min	typ	max	
Current drain	I_{CC0}	IN1 = IN2 = IN3 = 0V		0.1	1	μA
	I_{CC1}	IN1 or IN2 or IN3 = 3V $I_O = 100\text{mA}$ $R_F = 2\Omega$		5.8	8.0	mA
Output saturation voltage	V_{OUT1}	IN1 or IN2 or IN3 = 3V $I_O = 100\text{mA}$		0.2	0.32	V
	V_{OUT2}	IN1 or IN2 or IN3 = 3V $I_{OUT} = 200\text{mA}$ (Design specification)		0.41	0.62	V
Constant-current output	I_{OUT1}	Between RFG and ground: 2Ω	95	100	105	mA
	I_{OUT2}	Between RFG and ground: 1Ω (Design specification)	190	200	210	mA
Input current	I_{IN}	$V_{IN} = 3\text{V}$		50	70	μA
Spark killer diode						
Reverse current	$I_S(\text{leak})$				1	μA
Forward voltage	V_{SF}	$I_{OUT} = 100\text{mA}$			1.7	V
		$I_{OUT} = 200\text{mA}$ (Design specification)			1.7	V

Note: The design specifications are design guarantee values and are not tested.

Package Dimensions

unit : mm
3301A

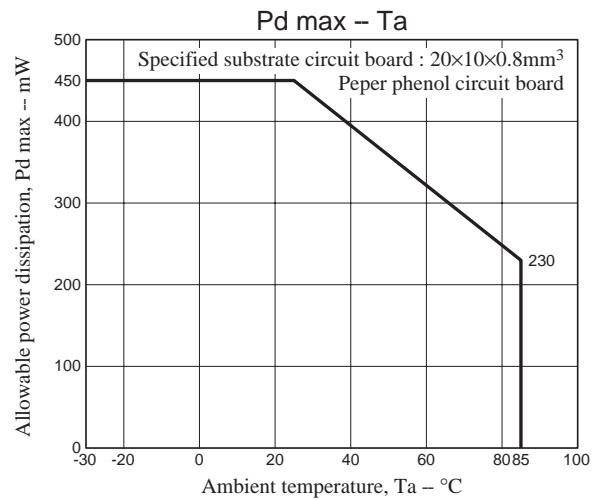
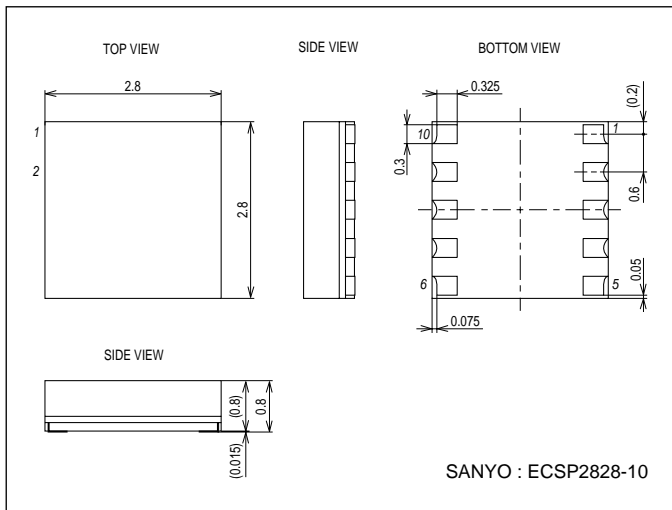

Pin Assignment

VCC	1	10	OUT1
IN1	2	9	RSE
IN2	3	8	RFG
IN3	4	7	OUT2
GND	5	6	OUT3

Top view

Block Diagram

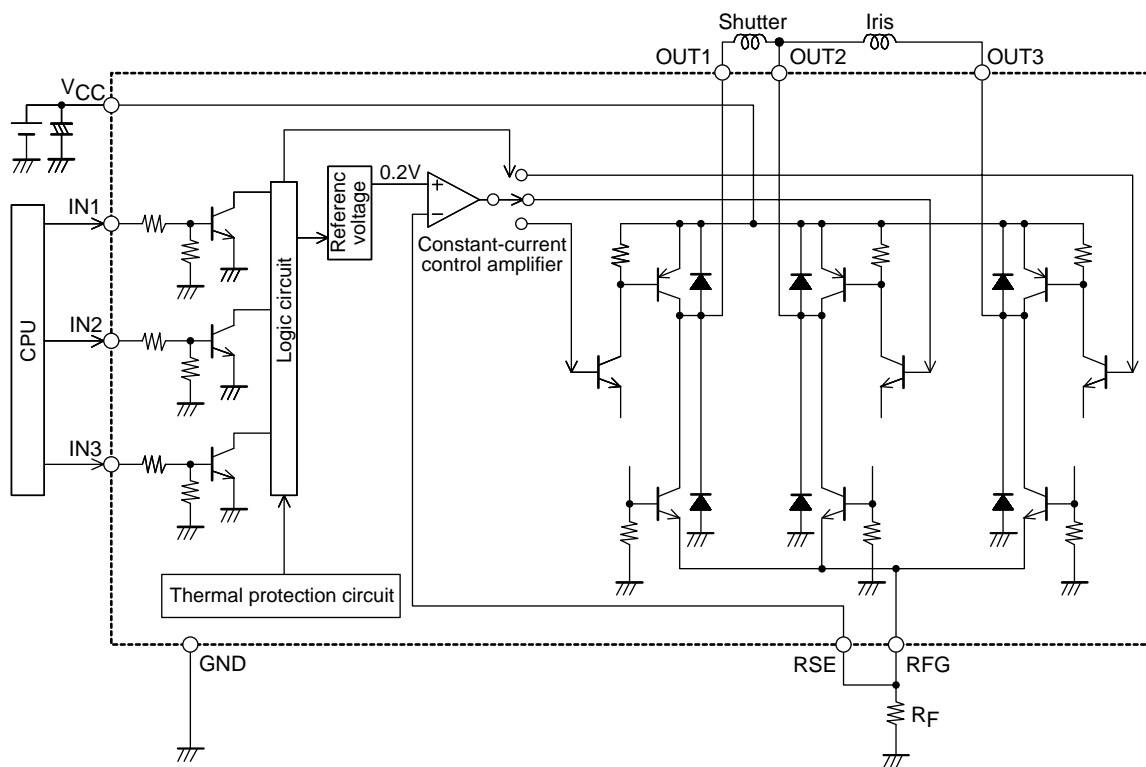

Constant-current formula: $I_{OUT} = 0.2/R_F$

Usage Notes

- If VCC is comparatively high, there are case where the use of a mechanical shutter will require 0.01μF capacitors to be inserted between the outputs (OUT pins).
- If only one channel is used and the supply voltage is comparatively high, there are case where the use of a mechanical shutter will require 0.01μF capacitors to be inserted between the outputs (OUT pins).
- The current is set by the value of the resistor RF inserted between RFG and ground according to the constant-current formula.

Truth Table

Input			Output			Notes	
IN1	IN2	IN3	OUT1	OUT2	OUT3		
L	Low	Low	-	-	-	Standby	
	High	Low	High	Low	-	Shutter	Forward
	Low	High	Low	High	-		Reverse
	High	High	Low	High	-		
H	Low	Low	-	-	-	Iris	OFF
	High	Low	-	Low	High		Forward
	Low	High	-	High	Low		Reverse
	High	High	-	High	Low		

Note 1. The [-] entry for the outputs indicates the off (high-impedance) state.

Timing Chart

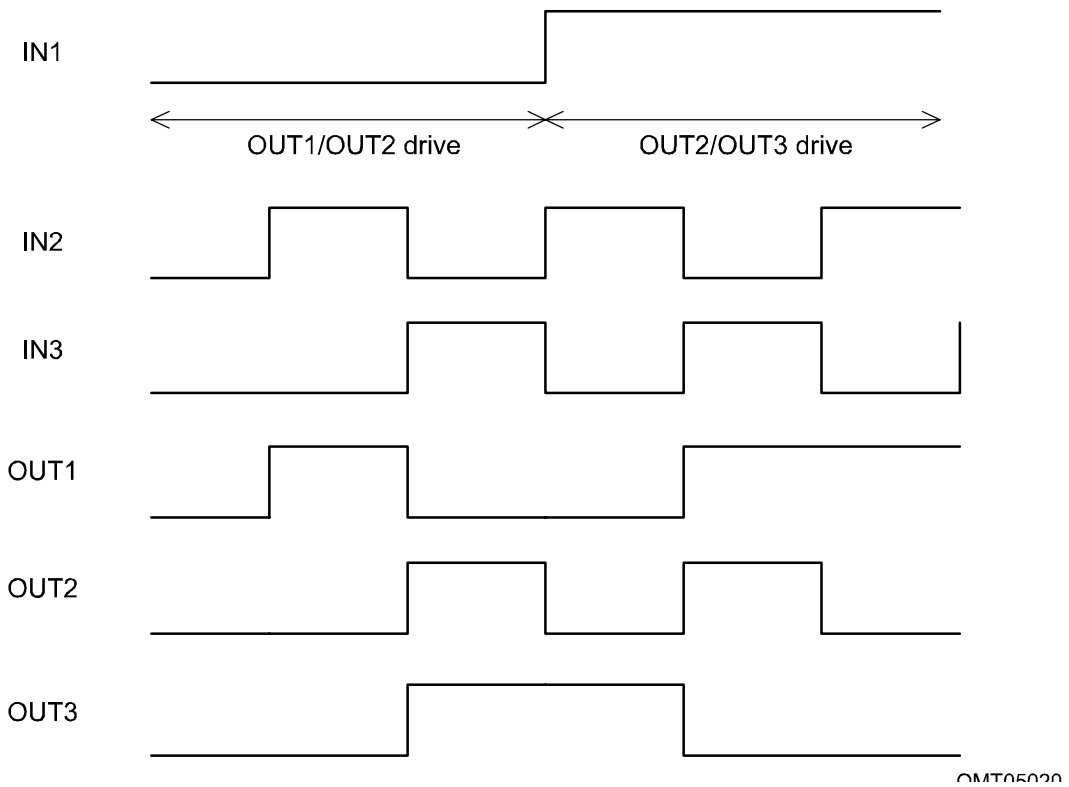

- The IN1 input selects OUT1/OUT2 or OUT2/OUT3 drive.
- The IN2 and IN3 inputs control forward/reverse switching.
- Broken lines (---) indicate the off state.
- During OUT1/OUT2 or OUT2/OUT3 drive, the output high side will be saturated and the low side not saturated. Also note that the output is a constant-current output.

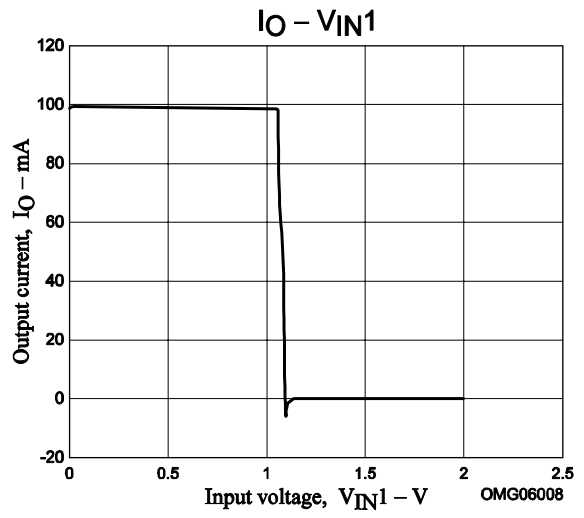
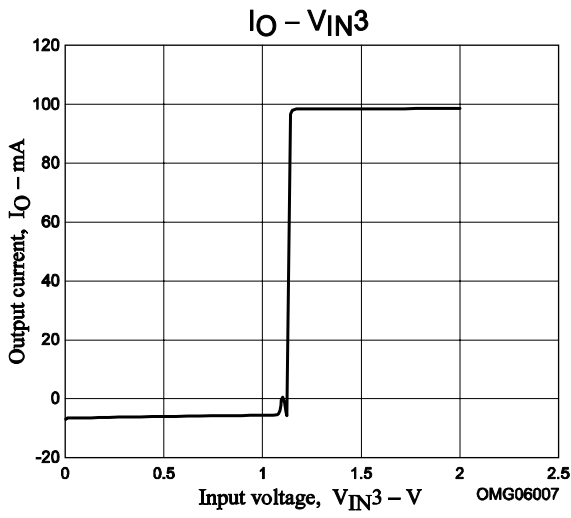
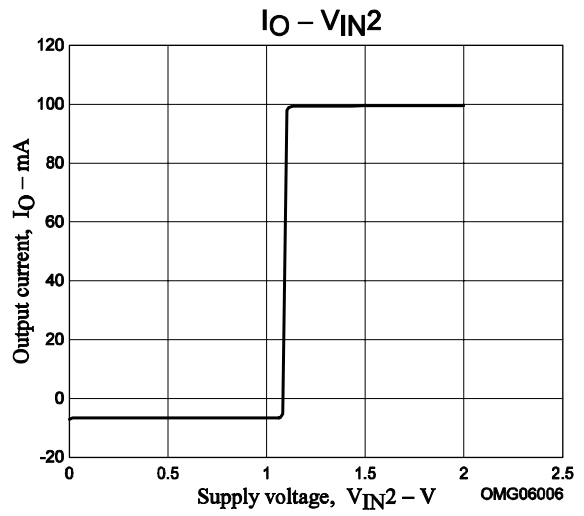
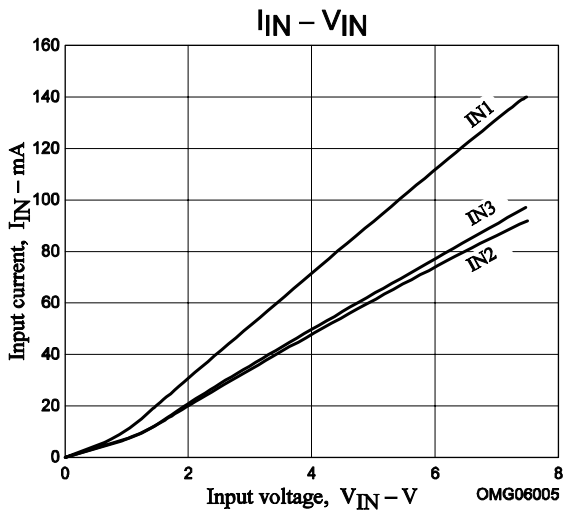
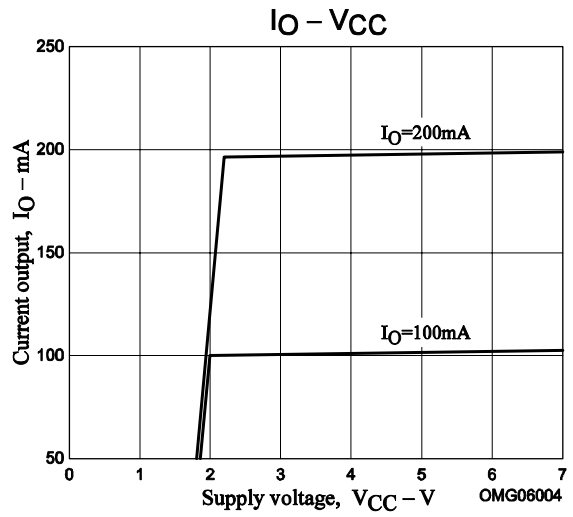
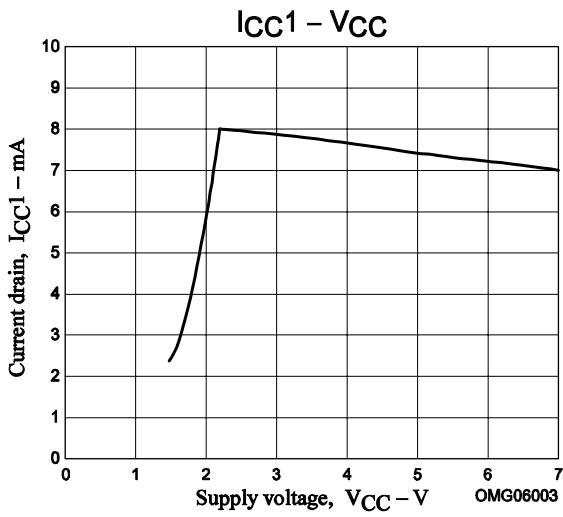

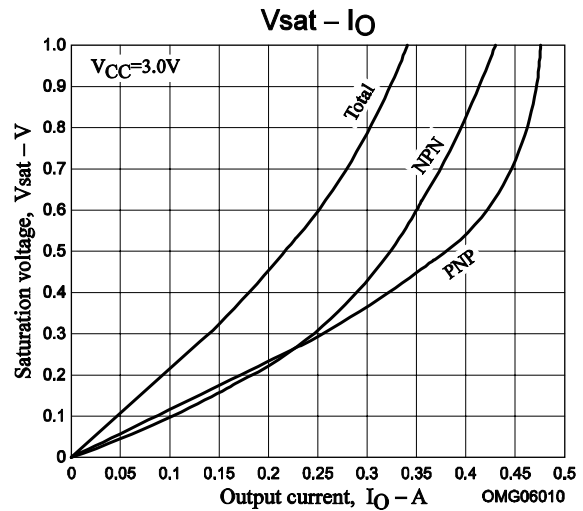
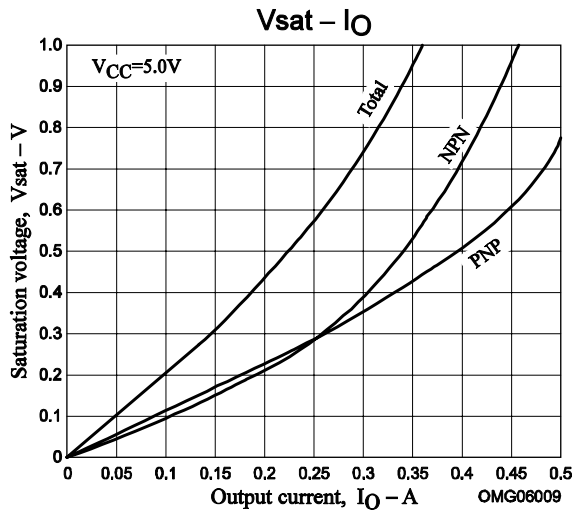

- SANYO Semiconductor Co.,Ltd. assumes no responsibility for equipment failures that result from using products at values that exceed, even momentarily, rated values (such as maximum ratings, operating condition ranges, or other parameters) listed in products specifications of any and all SANYO Semiconductor Co.,Ltd. products described or contained herein.
- SANYO Semiconductor Co.,Ltd. strives to supply high-quality high-reliability products, however, any and all semiconductor products fail or malfunction with some probability. It is possible that these probabilistic failures or malfunction could give rise to accidents or events that could endanger human lives, trouble that could give rise to smoke or fire, or accidents that could cause damage to other property. When designing equipment, adopt safety measures so that these kinds of accidents or events cannot occur. Such measures include but are not limited to protective circuits and error prevention circuits for safe design, redundant design, and structural design.
- In the event that any or all SANYO Semiconductor Co.,Ltd. products described or contained herein are controlled under any of applicable local export control laws and regulations, such products may require the export license from the authorities concerned in accordance with the above law.
- No part of this publication may be reproduced or transmitted in any form or by any means, electronic or mechanical, including photocopying and recording, or any information storage or retrieval system, or otherwise, without the prior written consent of SANYO Semiconductor Co.,Ltd.
- Any and all information described or contained herein are subject to change without notice due to product/technology improvement, etc. When designing equipment, refer to the "Delivery Specification" for the SANYO Semiconductor Co.,Ltd. product that you intend to use.
- Information (including circuit diagrams and circuit parameters) herein is for example only; it is not guaranteed for volume production.
- Upon using the technical information or products described herein, neither warranty nor license shall be granted with regard to intellectual property rights or any other rights of SANYO Semiconductor Co.,Ltd. or any third party. SANYO Semiconductor Co.,Ltd. shall not be liable for any claim or suits with regard to a third party's intellectual property rights which has resulted from the use of the technical information and products mentioned above.

This catalog provides information as of June, 2007. Specifications and information herein are subject to change without notice.