

### THYRISTOR SURGE PROTECTIVE DEVICE

$V_{DRM}: 58 - 320 V$   
 $I_{PP}: 30 A$

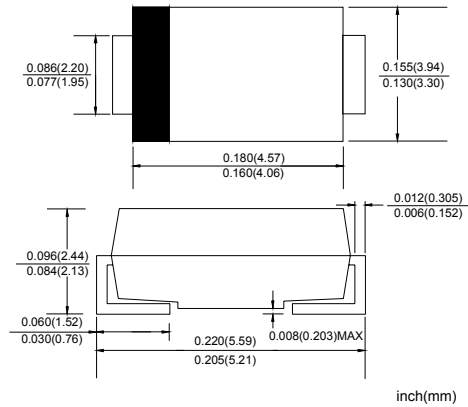
#### FEATURES

- Oxide glass passivated junction
- Bidirectional protection in a single device
- Surge capabilities up to 30A @10/1000us or 150A @8/20us
- High off state impedance and low on state voltage
- Plastic material has UL flammability classification 94V-0

#### MECHANICAL DATA

- Case: JEDEC SMB molded plastic
- Polarity: Denotes none cathode band
- Weight: 0.003 ounces, 0.093 grams

#### SMB



#### MAXIMUM RATINGS

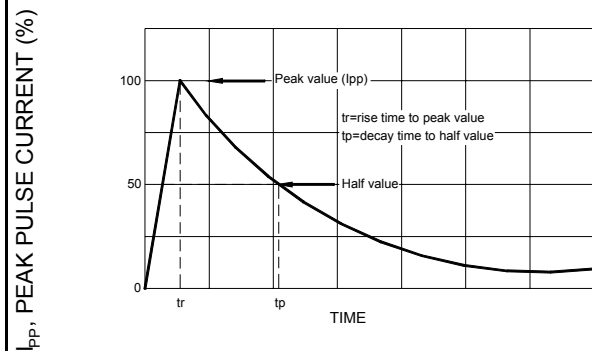
CHARACTERISTICS	SYMBOL	VALUE	UNIT
Non-repetitive peak impulse current @ 10/1000us	$I_{PP}$	30	A
Non-repetitive peak on-state current @ 8.3ms (one half cycle)	$I_{TSM}$	15	A
Junction temperature range	$T_J$	-55 --- +150	
Storage temperature range	$T_{STG}$	-55 --- +150	

#### THERMAL RESISTANCE

CHARACTERISTICS	SYMBOL	VALUE	UNIT
Junction to leads	$R_{\theta JL}$	30	/W
Junction to ambient on print circuit (on recommended pad layout)	$R_{\theta JA}$	120	/W
Typical positive temperature coefficient for brekdown voltage	$V_{BR}/T_J$	0.1	%/

#### MAXIMUM RATED SURGE WAVEFORM

WAVEFORM	STANDARD	$I_{PP}(A)$
2/10 us	GR-1089-CORE	200
8/20 us	IEC 61000-4-5	150
10/160 us	FCC Part 68	100
10/700 us	ITU-T K20/21	60
10/560 us	FCC Part 68	50
10/1000 us	GR-1089-CORE	30



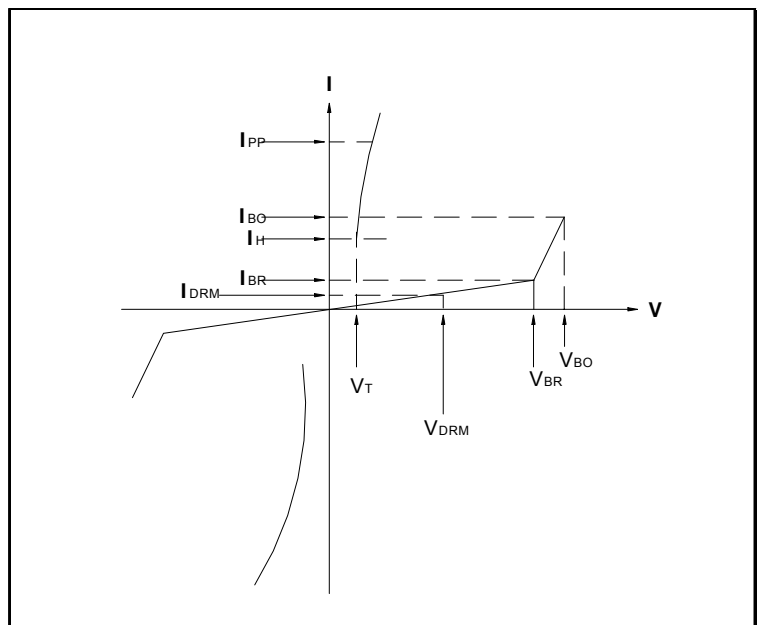
www.galaxycn.com

# RATINGS AND CHARACTERISTIC CURVES

PB064L --- PB350L

PARAMETER	RATED REPETITIVE OFF-STATE VOLTAGE	OFF-STATE LEAKAGE CURRENT @ $V_{DRM}$	BREAKOVER VOLTAGE	ON-STATE VOLTAGE @ $I_T=1.0A$	BREAKOVER CURRENT		HOLDING CURRENT		OFF-STATE CAPACITANCE
					$I_{BO-}$	$I_{BO+}$	$I_{H-}$	$I_{H+}$	
SYMBOL	$V_{DRM}$	$I_{DRM}$	$V_{BO}$	$V_T$	$I_{BO-}$	$I_{BO+}$	$I_{H-}$	$I_{H+}$	$C_o$
UNITS	VOLTS	$\mu A$	VOLTS	VOLTS	mA	mA	mA	mA	pF
LIMIT	MAX	MAX	MAX	MAX	MIN	MAX	MIN	MAX	TYP
P064L	58	5	77	3.5	50	800	150	800	140
P072L	65	5	88	3.5	50	800	150	800	440
P090L	75	5	98	3.5	50	800	150	800	440
P110L	90	5	130	3.5	50	800	150	800	90
P130L	120	5	160	3.5	50	800	150	800	90
P150L	140	5	180	3.5	50	800	150	800	90
P180L	160	5	220	3.5	50	800	150	800	90
P230L	190	5	265	3.5	50	800	150	800	60
P260L	220	5	300	3.5	50	800	150	800	60
P310L	275	5	350	3.5	50	800	150	800	60
P350L	320	5	400	3.5	50	800	150	800	60

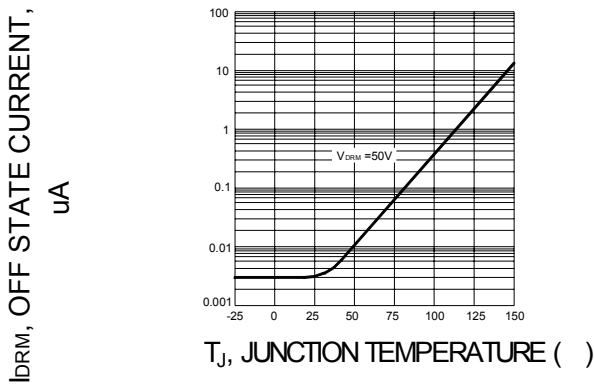
SYMBOL	PARAMETER
$V_{DRM}$	Stand-off voltage
$I_{DRM}$	Leakage current at stand-off voltage
$V_{BR}$	Breakdown voltage
$I_{BR}$	Breakdown current
$V_{BO}$	Breakover voltage
$I_{BO}$	Breakover current
$I_H$	Holding current Note:1
$V_T$	On state voltage
$I_{PP}$	Peak pulse current
$C_O$	Off state capacitance Note:2



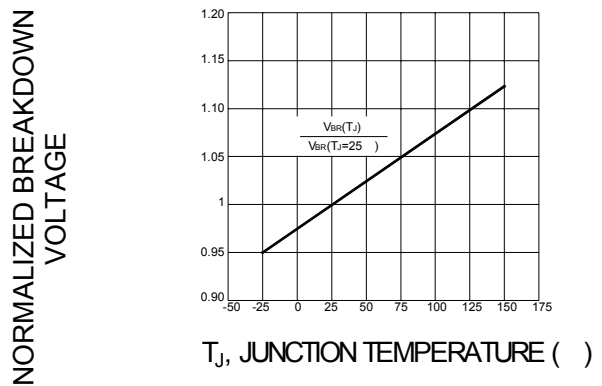
NOTES: 1.  $I_H > (V_T/R_L)$   $I_H$  this criterion is not obeyed, the  $T_{SPD}$  triggers but does not return correctly to high-resistance state. The surge recovery time does not exceed 30ms.

2. Off-state capacitance measured at  $f=1.0MHz$ ;  $1.0V_{RMS}$  signal;  $V_R=2V_{DC}$  bias.

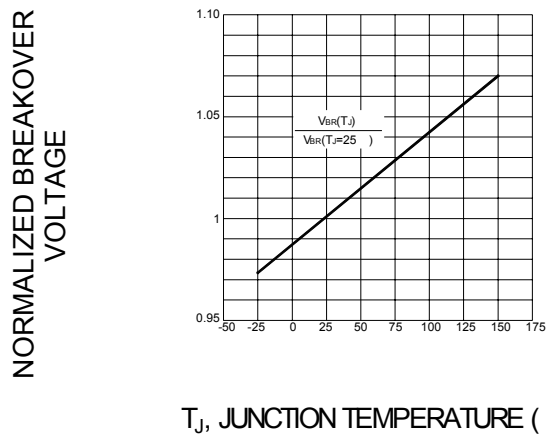
**FIG.1 – OFF STATE CURRENT vs JUNCTION TEMPERATURE**



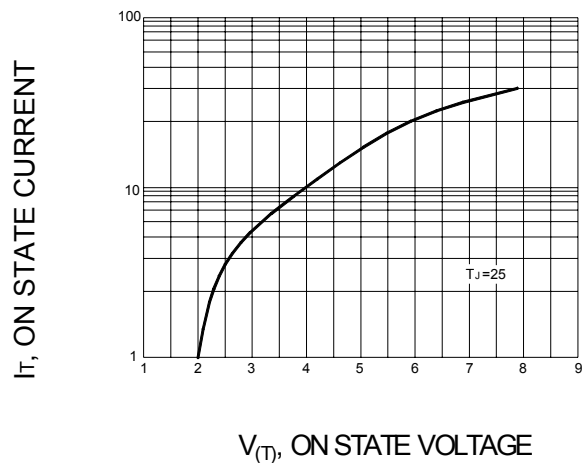
**FIG.2- RELATIVE VARIATION OF BREAKDOWN VOLTAGE vs JUNCTION TEMPERATURE**



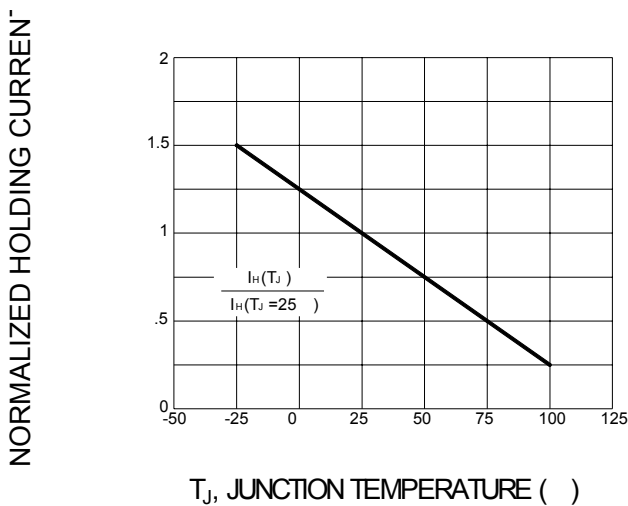
**FIG.3 – RELATIVE VARIATION OF BREAKOVER VOLTAGE vs JUNCTION TEMPERATURE**



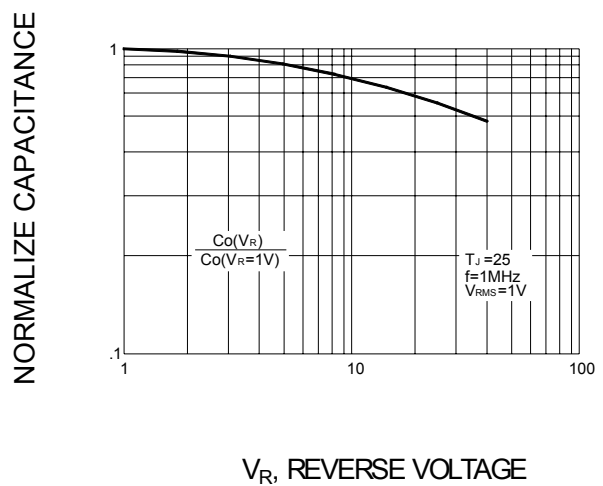
**FIG.4 – ON STATE CURRENT vs ON STATE VOLTAGE**

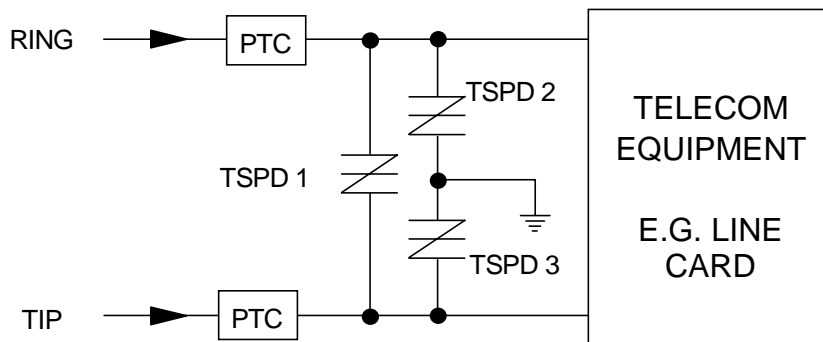
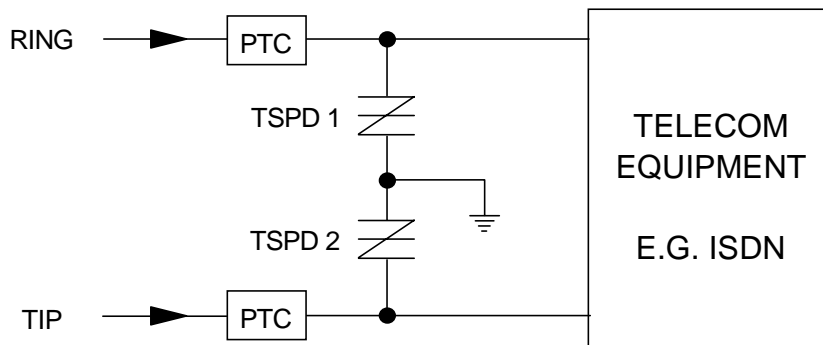
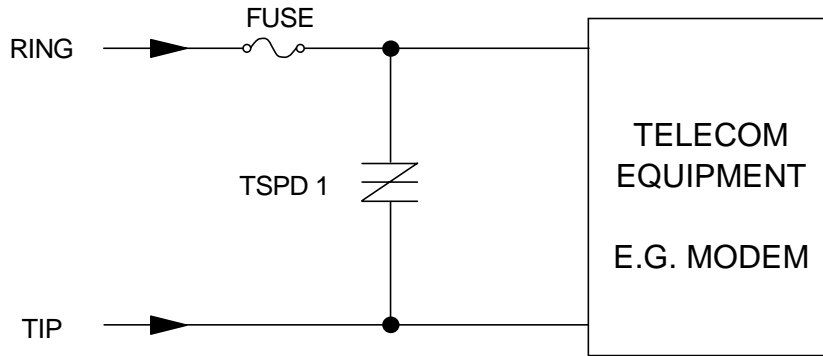


**FIG.5 – RELATIVE VARIATION OF HOLDING CURRENT vs JUNCTION TEMPERATURE**



**FIG.6 – RELATIVE VARIATION OF JUNCTION CAPACITANCE vs REVERSE VOLTAGE BIAS**





The PTC (Positive Temperature Coefficient) is an overcurrent protection device