

CA555, CA555C, LM555, LM555C

Timers for Timing Delays and Oscillator Application in Commercial, Industrial and Military Equipment

November 1996

Features

- Accurate Timing From Microseconds Through Hours
- Astable and Monostable Operation
- Adjustable Duty Cycle
- Output Capable of Sourcing or Sinking up to 200mA
- Output Capable of Driving TTL Devices
- Normally ON and OFF Outputs
- High Temperature Stability 0.005%/°C
- Directly Interchangeable with SE555, NE555, MC1555, and MC1455

Applications

- Precision Timing
- Sequential Timing
- Time Delay Generation
- Pulse Generation
- Pulse Detector
- Pulse Width and Position Modulation

Ordering Information

PART NUMBER (BRAND)	TEMP. RANGE (°C)	PACKAGE	PKG. NO.
CA0555E	-55 to 125	8 Ld PDIP	E8.3
CA0555M (555)	-55 to 125	8 Ld SOIC	M8.15
CA0555M96 (555)	-55 to 125	8 Ld SOIC †	M8.15
CA0555T	-55 to 125	8 Pin Metal Can	T8.C
CA0555CE	0 to 70	8 Ld PDIP	E8.3
CA0555CM (555C)	0 to 70	8 Ld SOIC	M8.15
CA0555CM96 (555C)	0 to 70	8 Ld SOIC †	M8.15
CA0555CT	0 to 70	8 Pin Metal Can	T8.C
LM555N	0 to 70	8 Ld PDIP	E8.3
LM555CN	0 to 70	8 Ld PDIP	E8.3

NOTE: † Denotes Tape and Reel

Description

The CA555 and CA555C are highly stable timers for use in precision timing and oscillator applications. As timers, these monolithic integrated circuits are capable of producing accurate time delays for periods ranging from microseconds through hours. These devices are also useful for astable oscillator operation and can maintain an accurately controlled free running frequency and duty cycle with only two external resistors and one capacitor.

The circuits of the CA555 and CA555C may be triggered by the falling edge of the waveform signal, and the output of these circuits can source or sink up to a 200mA current or drive TTL circuits.

These types are direct replacements for industry types in packages with similar terminal arrangements e.g. SE555 and NE555, MC1555 and MC1455, respectively. The CA555 type circuits are intended for applications requiring premium electrical performance. The CA555C type circuits are intended for applications requiring less stringent electrical characteristics.

Pinouts

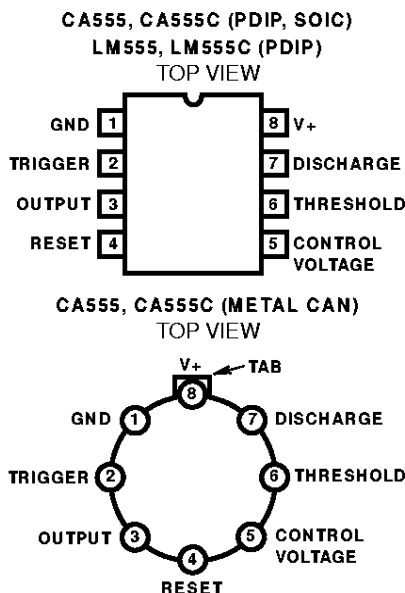

Functional Block Diagram

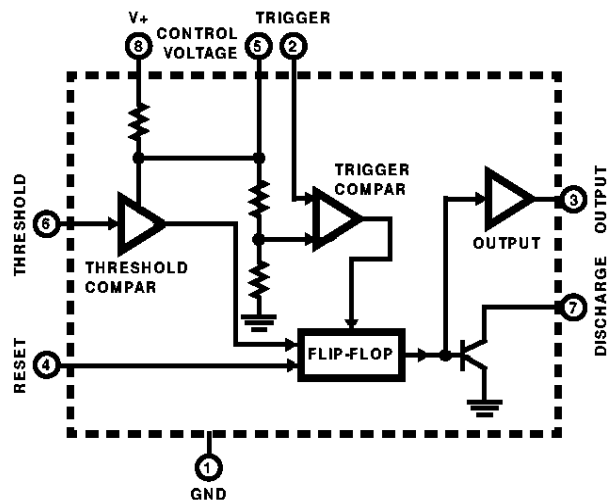

CA555, CA555C, LM555, LM555C

Absolute Maximum Ratings

DC Supply Voltage 18V

Operating Conditions

Temperature Range

CA555 -55°C to 125°C

CA555C, LM555, LM555C 0°C to 70°C

Thermal Information

Thermal Resistance (Typical, Note 1) θ_{JA} (°C/W) θ_{JC} (°C/W)

Metal Can Package 170 85

PDIP Package 100 N/A

SOIC Package 160 N/A

Maximum Junction Temperature (Hermetic Package) 175°C

Maximum Junction Temperature (Plastic Package) 150°C

Maximum Storage Temperature Range -65°C to 150°C

Maximum Lead Temperature (Soldering 10s) 300°C
(SOIC - Lead Tips Only)

CAUTION: Stresses above those listed in "Absolute Maximum Ratings" may cause permanent damage to the device. This is a stress only rating and operation of the device at these or any other conditions above those indicated in the operational sections of this specification is not implied.

NOTE:

- θ_{JA} is measured with the component mounted on an evaluation PC board in free air.

Electrical Specifications $T_A = 25^\circ\text{C}$, $V_+ = 5\text{V}$ to 15V Unless Otherwise Specified

PARAMETER	SYMBOL	TEST CONDITIONS	CA555, LM555			CA555C, LM555C			UNITS
			MIN	TYP	MAX	MIN	TYP	MAX	
DC Supply Voltage	V_+		4.5	-	18	4.5	-	16	V
DC Supply Current (Low State), (Note 2)	I_+	$V_+ = 5\text{V}$, $R_L = \infty$	-	3	5	-	3	6	mA
		$V_+ = 15\text{V}$, $R_L = \infty$	-	10	12	-	10	15	mA
Threshold Voltage	V_{TH}		-	$(2/3)V_+$	-	-	$(2/3)V_+$	-	V
Trigger Voltage		$V_+ = 5\text{V}$	1.45	1.67	1.9	-	1.67	-	V
		$V_+ = 15\text{V}$	4.8	5	5.2	-	5	-	V
Trigger Current			-	0.5	-	-	0.5	-	μA
Threshold Current (Note 3)	I_{TH}		-	0.1	0.25	-	0.1	0.25	μA
Reset Voltage			0.4	0.7	1.0	0.4	0.7	1.0	V
Reset Current			-	0.1	-	-	0.1	-	mA
Control Voltage Level		$V_+ = 5\text{V}$	2.9	3.33	3.8	2.6	3.33	4	V
		$V_+ = 15\text{V}$	9.6	10	10.4	9	10	11	V
Output Voltage Low State	V_{OL}	$V_+ = 5\text{V}$, $I_{SINK} = 5\text{mA}$	-	-	-	-	0.25	0.35	V
		$I_{SINK} = 8\text{mA}$	-	0.1	0.25	-	-	-	V
		$V_+ = 15\text{V}$, $I_{SINK} = 10\text{mA}$	-	0.1	0.15	-	0.1	0.25	V
		$I_{SINK} = 50\text{mA}$	-	0.4	0.5	-	0.4	0.75	V
		$I_{SINK} = 100\text{mA}$	-	2.0	2.2	-	2.0	2.5	V
		$I_{SINK} = 200\text{mA}$	-	2.5	-	-	2.5	-	V
Output Voltage High State	V_{OH}	$V_+ = 5\text{V}$, $I_{SOURCE} = 100\text{mA}$	3.0	3.3	-	2.75	3.3	-	V
		$V_+ = 15\text{V}$, $I_{SOURCE} = 100\text{mA}$	13.0	13.3	-	12.75	13.3	-	V
		$I_{SOURCE} = 200\text{mA}$	-	12.5	-	-	12.5	-	V
Timing Error (Monostable)		$R_1, R_2 = 1\text{k}\Omega$ to $100\text{k}\Omega$, $C = 0.1\mu\text{F}$	-	0.5	2	-	1	-	%
Frequency Drift with Temperature		Tested at $V_+ = 5\text{V}$, $V_+ = 15\text{V}$	-	30	100	-	50	-	ppm/°C
Drift with Supply Voltage			-	0.05	0.2	-	0.1	-	%/V

CA555, CA555C, LM555, LM555C

Electrical Specifications $T_A = 25^\circ\text{C}$, $V_+ = 5\text{V to } 15\text{V}$ Unless Otherwise Specified (Continued)

PARAMETER	SYMBOL	TEST CONDITIONS	CA555, LM555			CA555C, LM555C			UNITS
			MIN	TYP	MAX	MIN	TYP	MAX	
Output Rise Time	t_R		-	100	-	-	100	-	ns
Output Fall Time	t_F		-	100	-	-	100	-	ns

NOTES:

- When the output is in a high state, the DC supply current is typically 1mA less than the low state value.
- The threshold current will determine the sum of the values of R_1 and R_2 to be used in Figure 4 (astable operation); the maximum total $R_1 + R_2 = 20\text{M}\Omega$.

Schematic Diagram

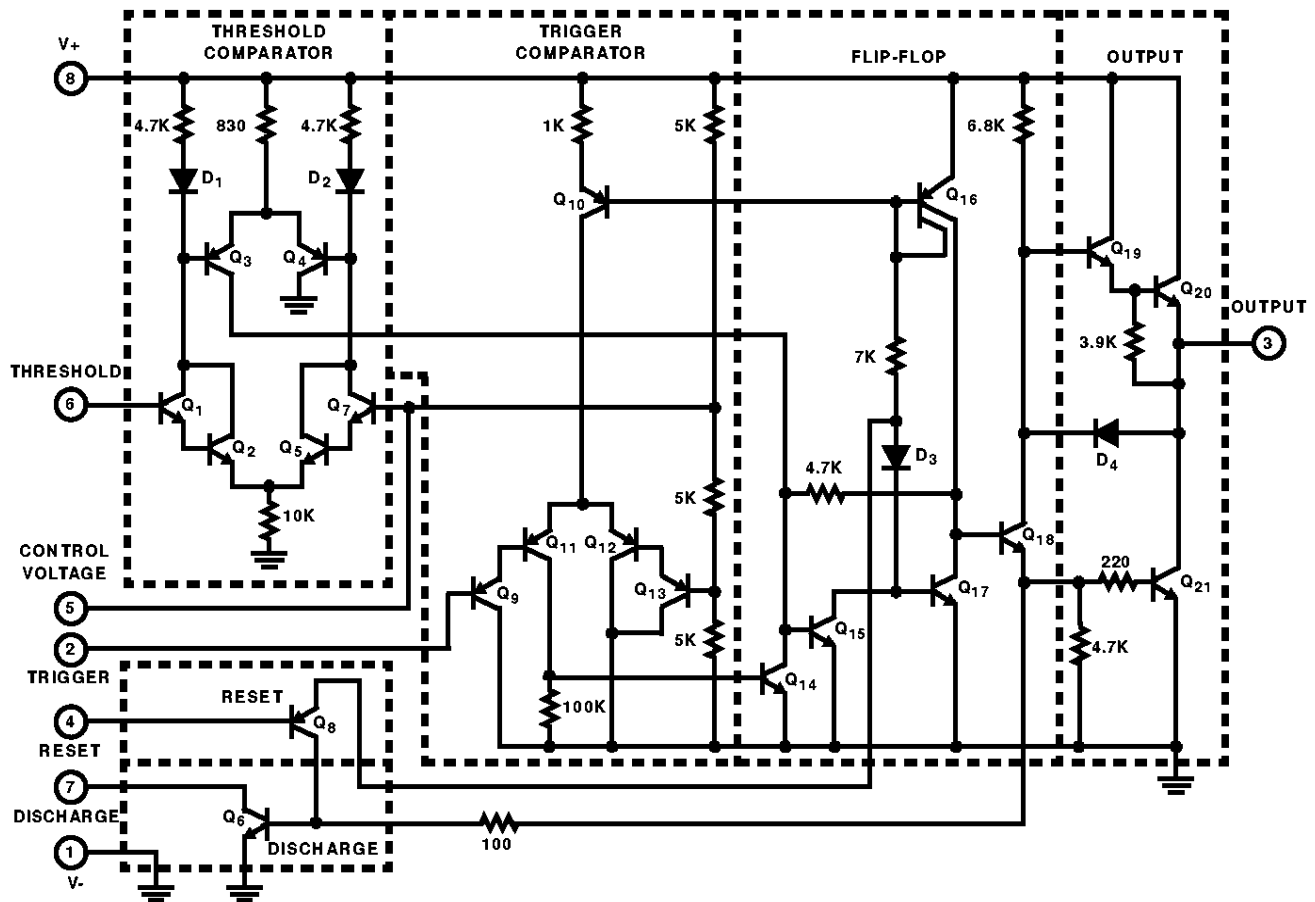

NOTE: Resistance values are in ohms.

Typical Applications

Reset Timer (Monostable Operation)

Figure 1 shows the CA555 connected as a reset timer. In this mode of operation capacitor C_T is initially held discharged by a transistor on the integrated circuit. Upon closing the "start" switch, or applying a negative trigger pulse to terminal 2, the integral timer flip-flop is "set" and releases the short circuit across C_T which drives the output voltage "high" (relay ener-

gized). The action allows the voltage across the capacitor to increase exponentially with the constant $t = R_1 C_T$. When the voltage across the capacitor equals $2/3 V_+$, the comparator resets the flip-flop which in turn discharges the capacitor rapidly and drives the output to its low state.

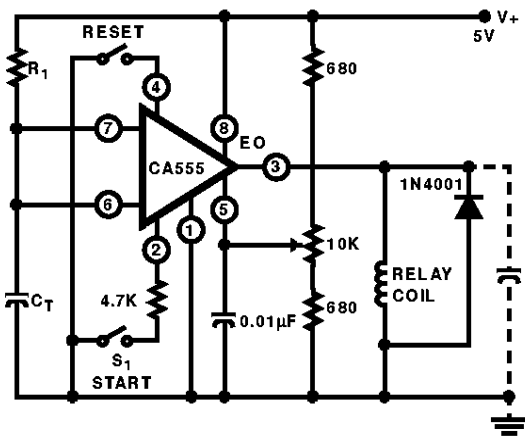

NOTE: All resistance values are in ohms.

FIGURE 1. RESET TIMER (MONOSTABLE OPERATION)

Since the charge rate and threshold level of the comparator are both directly proportional to V_+ , the timing interval is relatively independent of supply voltage variations. Typically, the timing varies only 0.05% for a 1V change in V_+ .

Applying a negative pulse simultaneously to the reset terminal (4) and the trigger terminal (2) during the timing cycle discharges C_T and causes the timing cycle to restart. Momentarily closing only the reset switch during the timing interval discharges C_T , but the timing cycle does not restart.

Figure 2 shows the typical waveforms generated during this mode of operation, and Figure 3 gives the family of time delay curves with variations in R_1 and C_T .

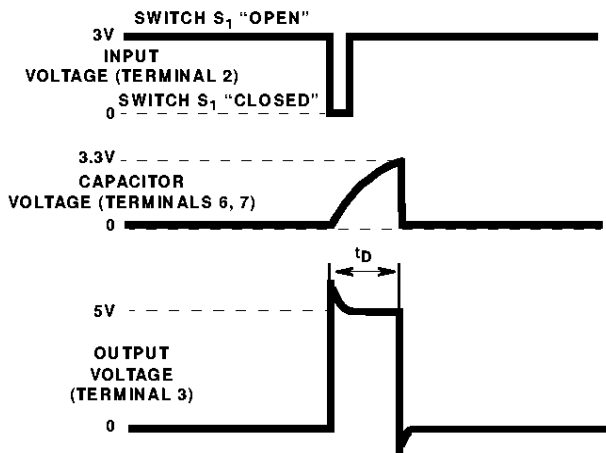

FIGURE 2. TYPICAL WAVEFORMS FOR RESET TIMER

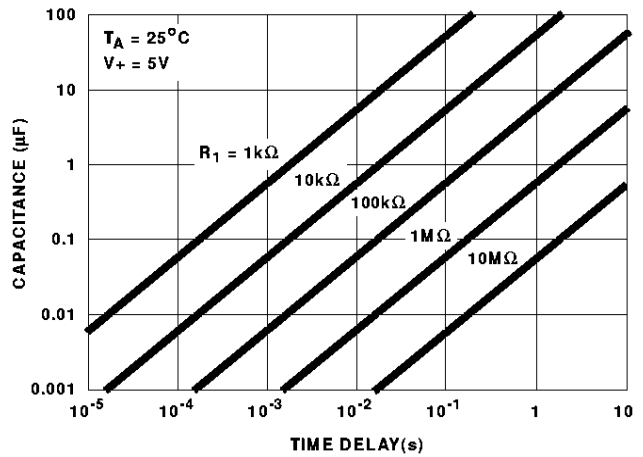

FIGURE 3. TIME DELAY vs RESISTANCE AND CAPACITANCE

Repeat Cycle Timer (Astable Operation)

Figure 4 shows the CA555 connected as a repeat cycle timer. In this mode of operation, the total period is a function of both R_1 and R_2 .

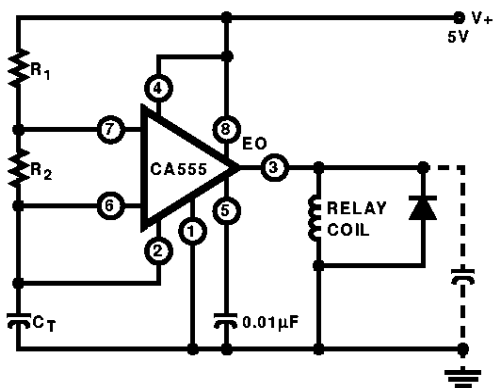

FIGURE 4. REPEAT CYCLE TIMER (ASTABLE OPERATION)

$$T = 0.693 (R_1 + 2R_2) C_T = t_1 + t_2$$

where $t_1 = 0.693 (R_1 + R_2) C_T$

and $t_2 = 0.693 (R_2) C_T$

the duty cycle is:

$$\frac{t_1}{t_1 + t_2} = \frac{R_1 + R_2}{R_1 + 2R_2}$$

Typical waveforms generated during this mode of operation are shown in Figure 5. Figure 6 gives the family of curves of free running frequency with variations in the value of $(R_1 + 2R_2)$ and C_T .

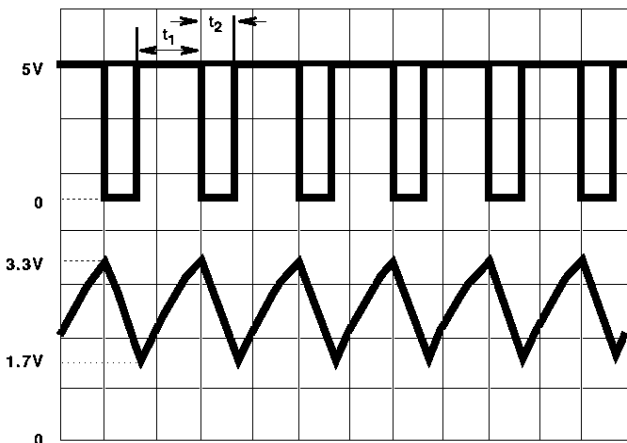

Top Trace: Output voltage (2V/Div. and 0.5ms/Div.)
Bottom Trace: Capacitor voltage (1V/Div. and 0.5ms/Div.)

FIGURE 5. TYPICAL WAVEFORMS FOR REPEAT CYCLE TIMER

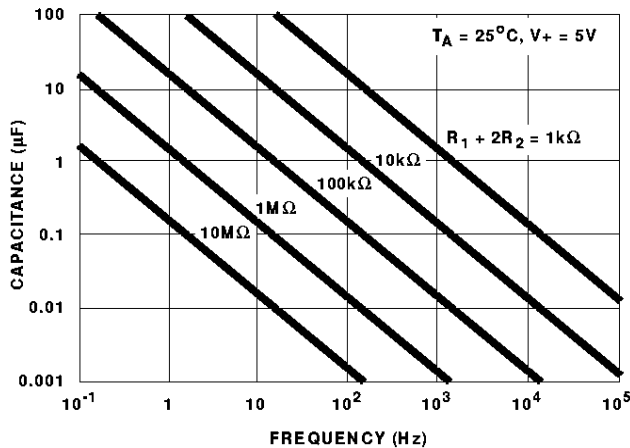
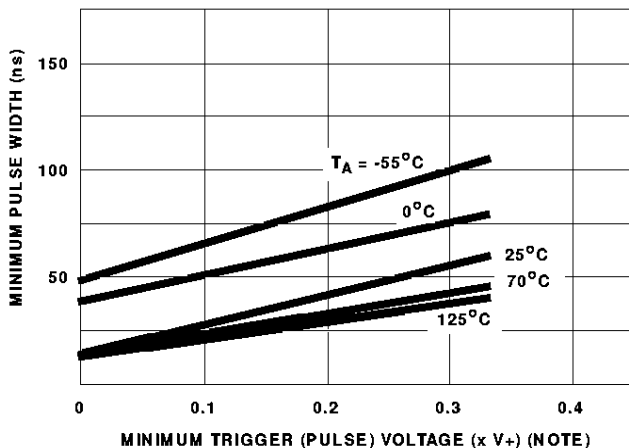

FIGURE 6. FREE RUNNING FREQUENCY OF REPEAT CYCLE TIMER WITH VARIATION IN CAPACITANCE AND RESISTANCE

Typical Performance Curves



NOTE: Where x is the decimal multiplier of the supply voltage.

FIGURE 7. MINIMUM PULSE WIDTH vs MINIMUM TRIGGER VOLTAGE

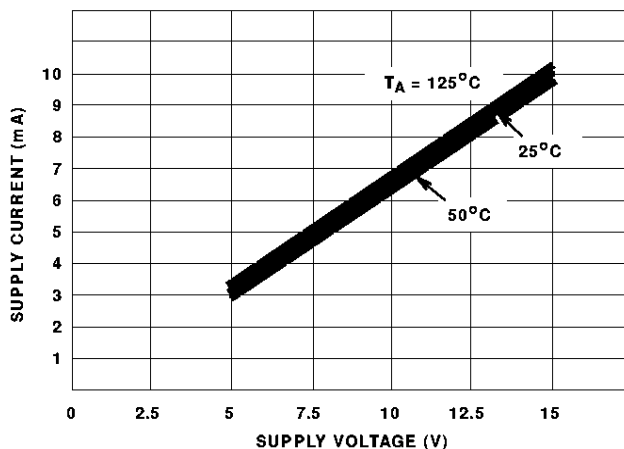

FIGURE 8. SUPPLY CURRENT vs SUPPLY VOLTAGE

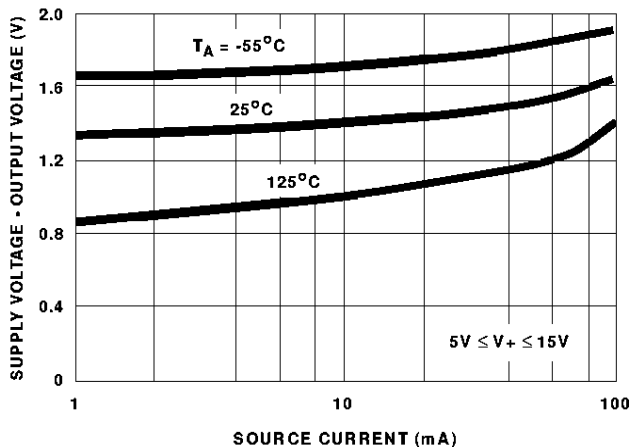

FIGURE 9. OUTPUT VOLTAGE DROP (HIGH STATE) vs SOURCE CURRENT

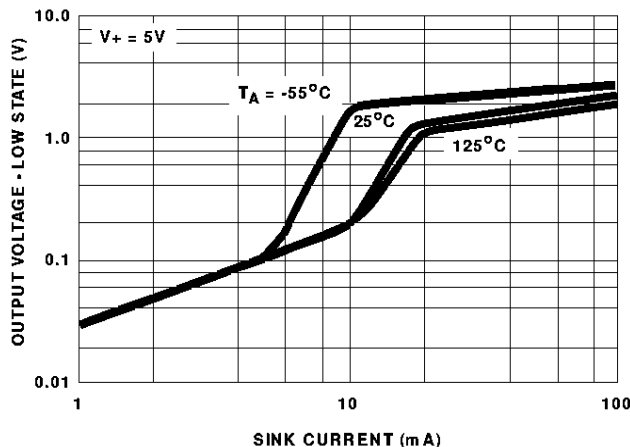

FIGURE 10. OUTPUT VOLTAGE LOW STATE vs SINK CURRENT

Typical Performance Curves (Continued)

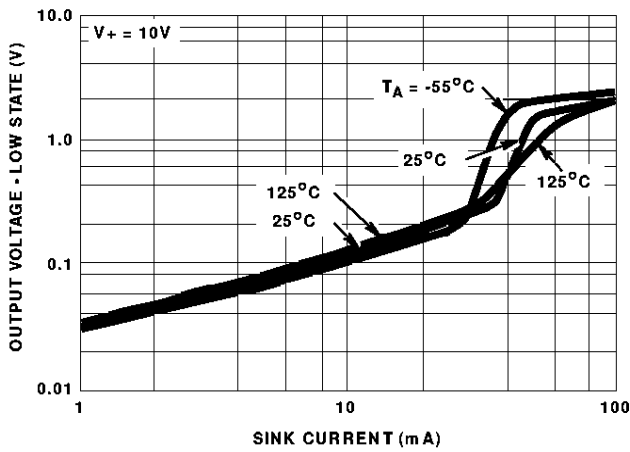

FIGURE 11. OUTPUT VOLTAGE LOW STATE vs SINK CURRENT

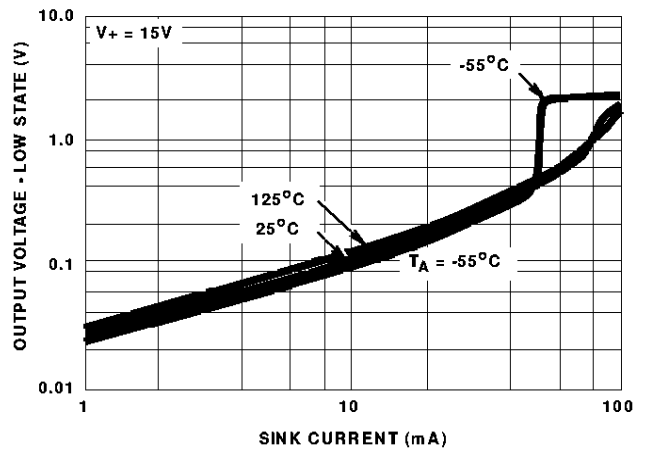

FIGURE 12. OUTPUT VOLTAGE LOW STATE vs SINK CURRENT

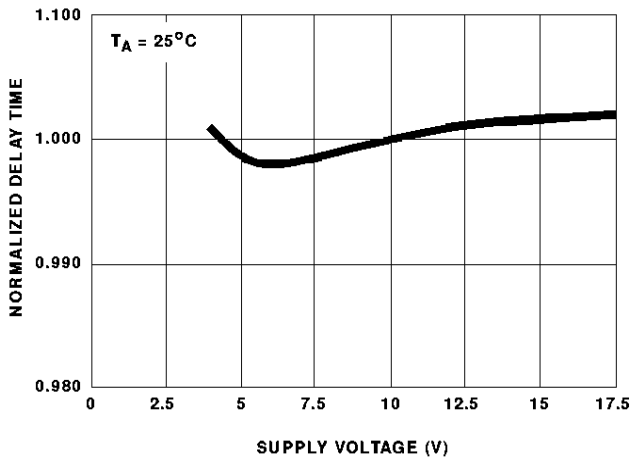

FIGURE 13. DELAY TIME vs SUPPLY VOLTAGE

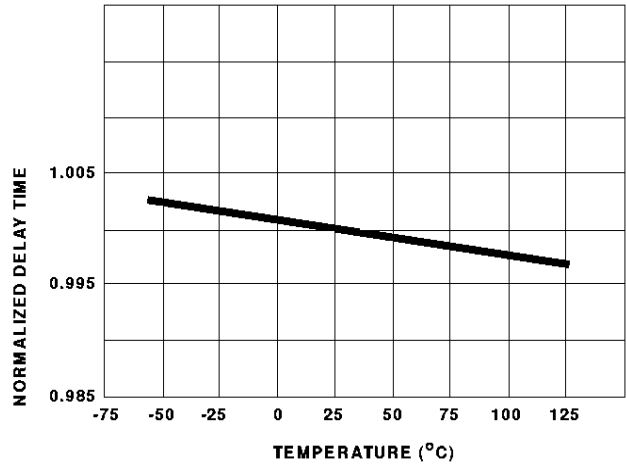
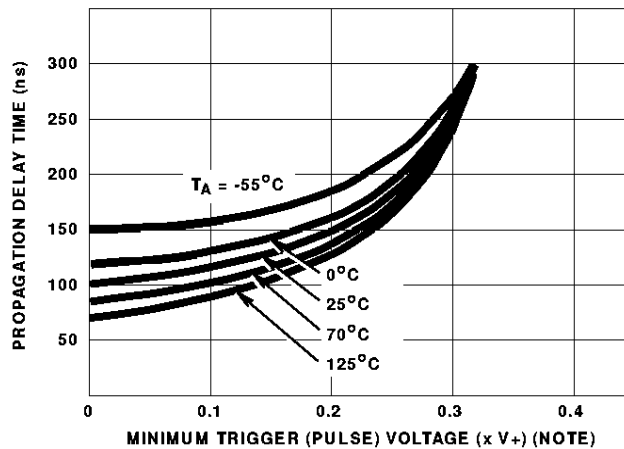

FIGURE 14. DELAY TIME vs TEMPERATURE



NOTE: Where x is the decimal multiplier of the supply voltage.

FIGURE 15. PROPAGATION DELAY TIME vs TRIGGER VOLTAGE