

DATA SHEET

FI1216MK2 Desktop video tuner system CCIR B/G

Preliminary specification
Supersedes data of 1996 Feb 16
File under Display Components, DC03

1997 Mar 13

Desktop video tuner system CCIR B/G

FI1216MK2

FEATURES

- System CCIR B/G
- True 5 V device (low power dissipation)
- Full frequency range from channel 2 (48.25 MHz) to channel 69 (855.25 MHz)
- PLL controlled tuning
- True-synchronous vision IF demodulator (PLL)
- Demodulated video output, AF sound output, second sound IF output
- I²C-bus control of tuning, address selection, AFC status information
- Complies with European regulations on radiation, signal handling and immunity ("*CENELEC 55020, 55013*" and "*Amtsblatt 15/92*")
- Small horizontally mounted metal housing.

DESCRIPTION

The FI1200MK2 family consists of the following types FI1216MK2, FI1246MK2, FI1256MK2. They are designed to meet a wide range of RF applications in the PC Multi-Media environment.

The FI1216MK2 types are available with a single 75 Ω input for TV reception. The input connector is available in either standard phono (female socket) or IEC (female socket).

The tuning and bandswitching are performed through the built-in digitally controlled I²C-bus. All front-ends meet the input immunity and radiation of CENELEC.

The FI1216MK2 consists of a tuner section and an IF section, which are all designed on a single PCB. The front-end is assembled in a metal housing made of a rectangular tin plated steel frame with front and rear covers which have soldered contacts to the frame. A single phono or IEC aerial socket is mounted on one side of the frame. All other connections are made via pins at the bottom.

The tuner section is equipped with 3 tuned RF MOSFET input stages, with a 3-band mixer-oscillator IC, containing the oscillators, mixers and IF amplifier. Tuning and band switching in the tuner section are done with a digital programmable PLL tuning system. This enables tuning with step-size programmable between 31.25, 50.0 or 62.5 kHz. A DC-DC converter is built around the PLL synthesizer IC to provide the tuning voltage, thus making the FI1216MK2 front-end a true 5 V device.

The IF section uses a true-synchronous vision IF demodulator (PLL) with an intercarrier SAW filter in front of it.

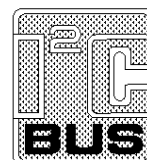

The analog AFC voltage is fed to the 5-level A/D converter in the PLL tuning IC, so that the AFC status can be read via the I²C-bus.

ORDERING INFORMATION

TYPE	DESCRIPTION	CATALOGUE NUMBERS
FI1216MK2/HM/PH	standard phono	3139 147 13291
FI1216MK2/HM/IEC	IEC	3139 147 13301

MARKING

The following items of information are printed on a sticker that is on the top cover of the tuner:

- Type number
- Code number
- Origin letter of factory
- Change code
- Year and week code.

INTERMEDIATE FREQUENCIES

SYSTEM	FREQUENCY ⁽¹⁾ (MHz)
	PAL B/G
Picture carrier	38.90
Colour	34.47
Sound 1	33.40
Sound 2	33.16
NICAM	33.05

Note

1. The oscillator frequency is above the input signal frequency.

CHANNEL COVERAGE

BAND	CHANNELS
Low band	48.25 to 170.00 MHz
Mid band	170.00 to 450.00 MHz
High band	450.00 to 855.25 MHz

Desktop video tuner system CCIR B/G

FI1216MK2

BLOCK DIAGRAM

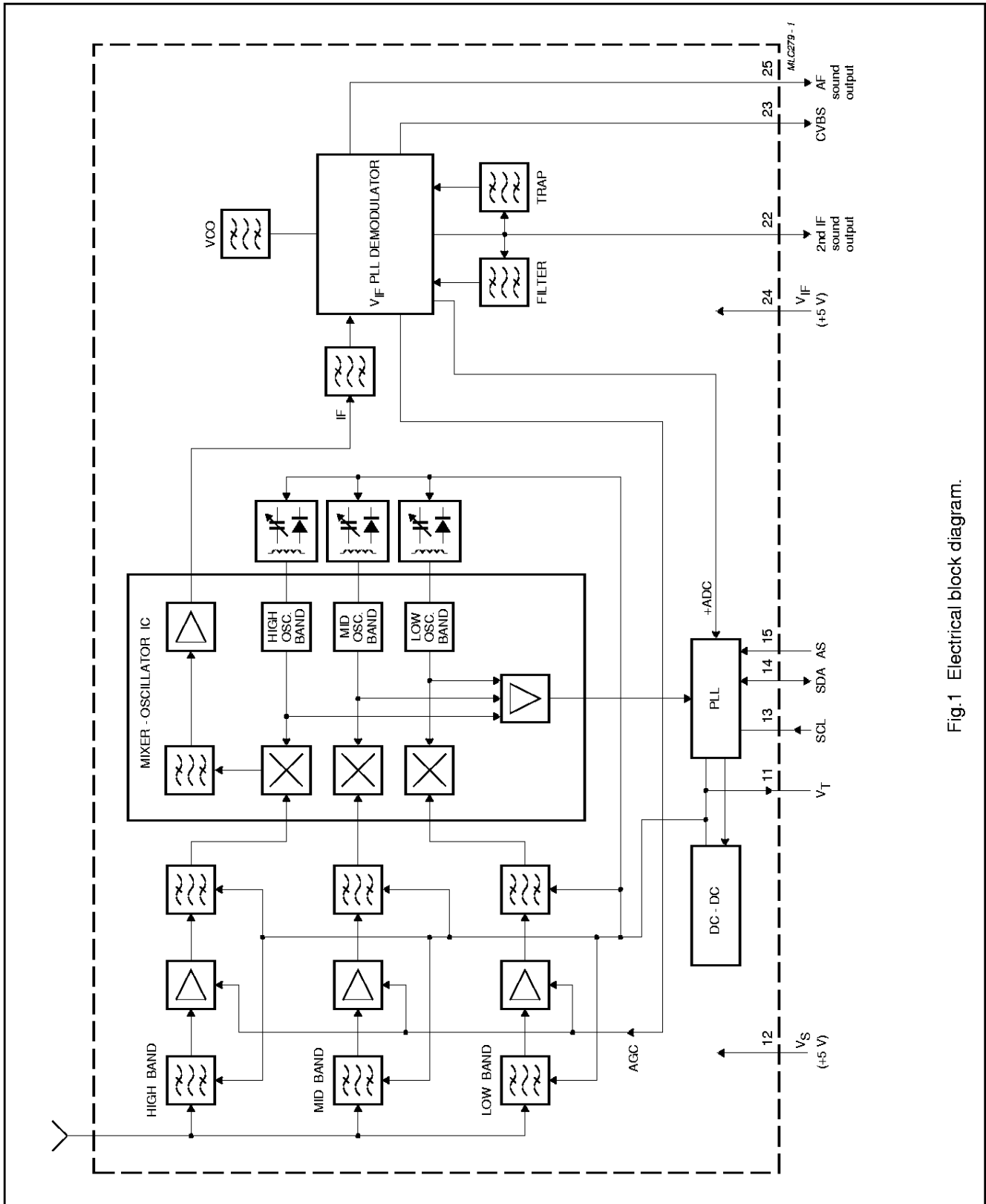

Fig.1 Electrical block diagram.

**Desktop video tuner
system CCIR B/G**

F11216MK2

PINNING

SYMBOL	PIN	DESCRIPTION
V _T	11	tuning voltage (monitor)
V _S	12	supply voltage tuner section +5 V
SCL	13	I ² C-bus serial clock
SDA	14	I ² C-bus serial data
AS	15	I ² C-bus address select
n.c.	21	not connected
2 nd IF sound output	22	second IF sound output
CVBS	23	Composite Video Baseband Signal output
V _{IF}	24	supply voltage IF section +5 V
AF sound output	25	AF sound output
—	TH1, TH2, TH3 and TH4	mounting tags (ground)

Desktop video tuner system CCIR B/G

FI1216MK2

LIMITING VALUES

Limiting values under operational conditions

The tuner can be guaranteed to function properly under the following conditions.

SYMBOL	PARAMETER	PIN	MIN.	TYP.	MAX.	UNIT
V_S	supply voltage	12	4.75	5.00	5.25	V
$V_{S(\text{ripple})}$	peak-to-peak ripple voltage susceptibility (at 5 V \pm 5%); note 1					
	20 Hz to 100 kHz		–	–	20	mV
	>100 kHz to 500 kHz		–	–	10	mV
I_S	supply current		–	–	120	mA
V_{SCL}	SCL bus input voltage	13	–0.3	–	+5.25	V
V_{SDA}	SDA bus input voltage	14	–0.3	–	+5.25	V
I_{SDA}	SDA bus current (open collector)		–1	–	+5	mA
V_{AS}	address select voltage; note 2	15	–	–	+5.25	V
Z_{IF}	2 nd IF sound output load impedance:	22				
	DC		0.5	–	–	k Ω
	AC		0.5	–	–	k Ω
Z_{CVBS}	Composite Video Baseband Signal load impedance:	23				
	DC		–	75	–	Ω
	AC		–	75	–	Ω
t_L	load time constant		–	–	100	ns
V_{IF}	IF supply voltage	24	4.75	5.0	5.25	V
$V_{IF(\text{ripple})}$	peak-to-peak ripple voltage susceptibility (at 5 V \pm 5%); note 1					
	20 Hz to 100 kHz		–	–	20	mV
	>100 kHz to 500 kHz		–	–	10	mV
I_{IF}	IF supply current		–	–	100	mA
Z_{AF}	AF sound output load impedance:	25				
	DC		1.0	–	–	k Ω
	AC		0.6	–	–	k Ω

Notes

1. Sinusoidal ripple voltage superimposed on the 5 V supply voltage in the frequency range of 20 Hz to 500 kHz. Criteria for TV interference >57 dB.
2. For detailed information about the address decoding, refer to Chapter "Application information".

**Desktop video tuner
system CCIR B/G**
F1216MK2
Environmental conditions

SYMBOL	PARAMETER	CONDITIONS	MIN.	TYP.	MAX.	UNIT
Non-operational conditions						
T _{amb}	ambient temperature		-25	-	+85	°C
RH	relative humidity		-	-	100	%
g _B	bump acceleration	25 g	-	-	245	m/s ²
g _S	shock acceleration	50 g	-	-	490	m/s ²
	vibration amplitude	10 to 55 Hz	-	0.35	-	mm
Operational conditions						
T _{amb}	ambient temperature		-10	-	+60	°C
RH	relative humidity		-	-	95	%

OVERALL PERFORMANCE
Conditional data

Unless otherwise specified, all electrical values for Chapter "Overall performance" apply at the following conditions.

SYMBOL	PARAMETER	VALUE	UNIT
T _{amb}	ambient temperature	25 ±5	°C
RH	relative humidity	60 ±15	%
V _S	supply voltage (tuner and IF section)	5 ±0.125	V
Z _{CVBS}	video output load impedance (DC)	>75	Ω
Z _{IF}	IF sound output load impedance (DC)	>500	Ω
t _{pr}	pre-heating time (+5 V at pin 24)	10	minute
Z _{S(AE)}	aerial source impedance (unbalanced)	75	Ω

**Desktop video tuner
system CCIR B/G**

FI1216MK2

TUNER SECTION**Tuner characteristics**

For detailed information about the PLL programming, refer to Chapter "Application information".

The desktop video tuner is guaranteed to function properly within the specified operational conditions, but a certain deterioration of performance parameters may occur at the limits of the operational conditions.

Test equipment

EQUIPMENT	PARAMETER	VALUE	UNIT
DC voltmeter	input impedance	>1	M Ω
Oscilloscope	input impedance: resistance capacitance	>1 <15	M Ω pF
Spectrum analyzer	input impedance	50	Ω
FET probe	input impedance: resistance capacitance	1 3.5	M Ω pF
	output impedance	50	Ω
	voltage gain	0	dB

Desktop video tuner
system CCIR B/G

FI1216MK2

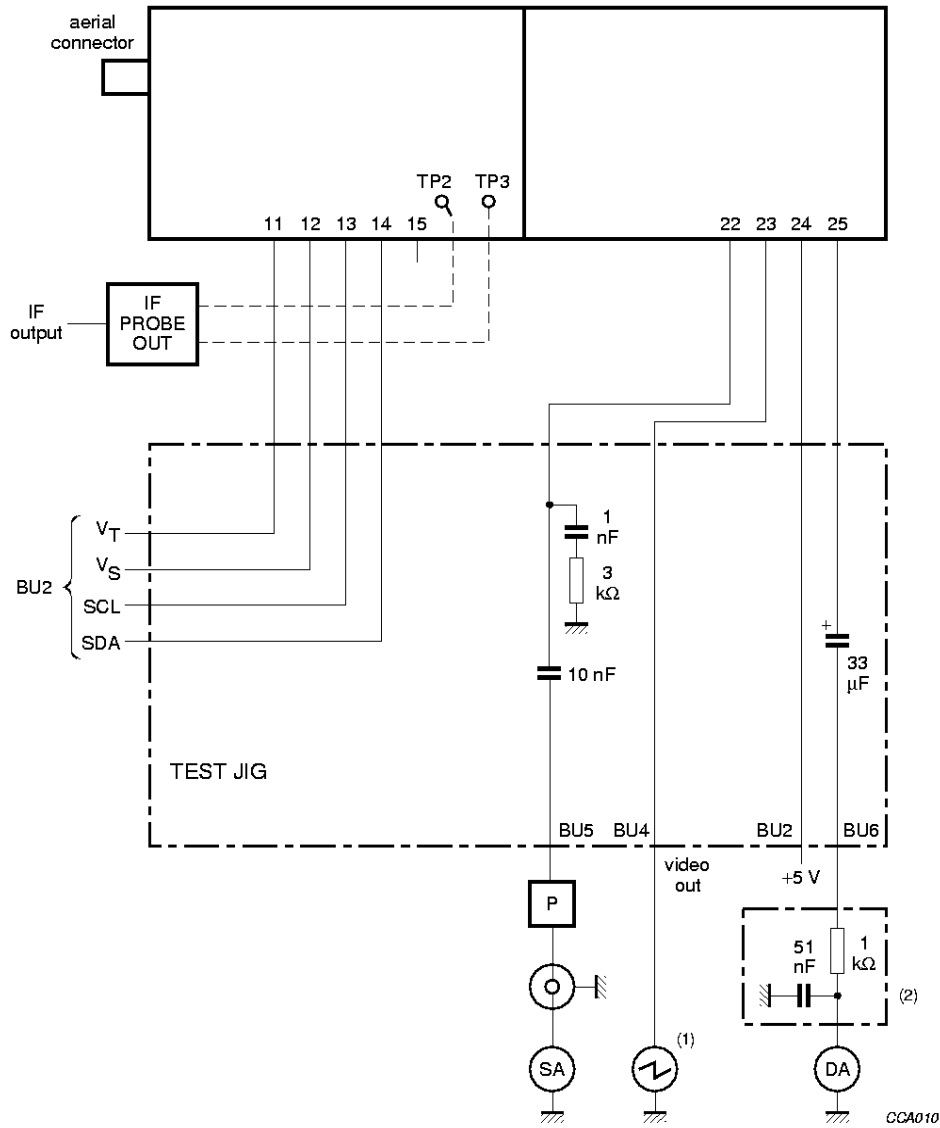

- (1) BU4 loaded with 75 Ω.
- (2) 50 μs de-emphasis.
- SA = spectrum analyzer.
- P = FET probe.
- DA = distortion analyzer.

Fig.2 Typical test set up.

**Desktop video tuner
system CCIR B/G**
FI1216MK2
Definitions of test signals (see Fig.2)

TEST SIGNAL	FREQ. (MHz)	AMPLITUDE	MODULATION	
			VIDEO	AUDIO
A0: unmodulated vision carrier	480.25	60 dB μ V		
A1: CCIR B/G standard signal with video modulation	480.25	60 dB μ V (top sync)	100% (rest carrier 10%) 2T pulse and bar	
B1: unmodulated sound carrier B/G system	485.75	-13 dB w.r.t. A0 to A1		
B2: FM modulated sound carrier B/G system	485.75	-13 dB w.r.t. A0 to A1		1 kHz; modulation frequency deviation ± 27 kHz; 50 μ s pre-emphasis
B3: unmodulated sound carrier B/G system	478.75	-13 dB w.r.t. A0 to A1		

Aerial input characteristics

SYMBOL	PARAMETER	CONDITIONS	MIN.	MAX.	UNIT
V _{SWR}	reflection coefficient	referred to 75 Ω impedance (worst case on or between picture and sound carrier at maximum gain)	-	5	
V _{PSM}	surge protection voltage		5	-	kV
V _{ant}	antenna connection disturbance voltage	<1.75 GHz	-	46	dB μ V

Desktop video tuner system CCIR B/G

FI1216MK2

General characteristics

SYMBOL	PARAMETER	CONDITIONS	MIN.	TYP.	MAX.	UNIT
f_b	frequency range: low band mid band high band		48.25 175.25 455.25	– – –	168.25 447.25 855.25	MHz MHz MHz
Δf_b	margin: for low band for mid/high band		1.5 3	– –	– –	MHz MHz
α_i	image rejection (nominal gain to 10 dB gain reduction): low band mid band mid band high band	<300 MHz >300 MHz	70 66 60 50	– – – –	– – – –	dB dB dB dB
α_{IF}	IF rejection (picture)		60	–	–	dB
Z_{IF}	$\frac{1}{2}$ IF susceptibility: E2 to E12 E21 to E69		75 60	– –	– –	dB μ V dB μ V
α_S	sound-chrominance moiré rejection: off-air UHF	up to 40 dB gain control up to 30 dB minimum gain control	56 56	– –	– –	dB dB
m_x	cross modulation: in-channel in-band low band ($n \pm 2$) mid band ($n \pm 3$) high band ($n \pm 5$) out of band		70 78 78 84 –	– – – – 100	– – – – –	dB μ V dB μ V dB μ V dB μ V dB μ V
	breakthrough susceptibility: E2 to E12; E21 to E69		60	–	–	dB μ V
V_{osc}	oscillator voltage at all pins		–	–	70	dB μ V
t_{li}	oscillators lock-in time	charge pump set logic HIGH	–	–	150	ms
α_{vs}	the video signal-to-sound interference ratio with the tuner exposed to sound signals in the audio frequency range 100 Hz to 10 kHz and sound pressure levels up to 105 dB (20 μ Pa)		40	–	–	dB
V_{ESD}	electrostatic discharge (ESD) on all pins	note 1	2	–	–	kV

Note

1. All the pins of the desktop video tuner are protected against electrostatic discharge (ESD) up to 2 kV. The product is classified in category B ("MIL-STD-883C").

Desktop video tuner system CCIR B/G

FI1216MK2

Video and audio characteristics (see Fig.2)

PARAMETER	TEST SIGNAL	TEST POINT	MIN.	TYP.	MAX.	UNIT
CVBS characteristics:						
video amplitude signal at pin 23	A1 (peak-to-peak value)	BU4	0.7	–	1.1	V
DC level sync pulse at pin 23	A1	BU4	–	0.35	–	V
Video amplitude drop with respect to modulation 0.1 MHz at $T_{amb} = 45\text{ }^{\circ}\text{C}$:						
at 1 MHz	A1	BU4	–1.0	–	+1.0	dB
at 2 MHz	A1	BU4	–1.5	–	+1.5	dB
at 3 MHz	A1	BU4	–2.5	–	+1.5	dB
at 4 MHz	A1	BU4	–3.0	–	+2.0	dB
at 4.43 MHz	A1	BU4	–4.0	–	+2.0	dB
Sound carrier rejection	A1 (1 MHz) + B1	BU4	40	–	–	dB
Residual 40.4 MHz signal in video channel: level of 1.5 MHz	A1 + B3	BU4	–	–	68	dB μ V
Residual 77.8 MHz signal in video channel	A1	BU4	–	–	80	dB μ V
Second IF sound output level at level of 5.5 MHz	A1 + B1	BU5	84	–	–	dB μ V
Test on 2T pulse at $T_{amb} = 45\text{ }^{\circ}\text{C}$:						
2T pulse/bar response	A1	BU4	–2.5	–	+2.5	%
2T pulse response	A1	BU4	–	–	+3.0	%
CVBS S/N (unweighted)	A1 + B1	BU4	41	–	–	dB
Gain limited sensitivity at 1 dB reduction of video output	A1	BU4	–	–	30	dB μ V
Audio characteristics:						
AF output level measured via LP 20 kHz filter, RMS detector, 50 μ s de-emphasis	A1 + B2	BU6	0.25	0.35	0.50	V
THD (Total Harmonic Distortion) measured via LP 20 kHz filter, RMS detector, 50 μ s de-emphasis	A1 + B2	BU6	–	–	0.5	%
S/N measured via CCIR filter, peak CCIR detector, 50 μ s de-emphasis	A1 (6 kHz sine wave, black-to-white) + B1	BU6	41	–	–	dB
AF 3 dB response measured via LP 20 kHz filter, RMS detector, de-emphasis off	A1 (black) + B1	BU6	16	–	–	kHz
AM suppression ratio	A1 + B2	BU6	40	–	–	dB

Digital AFC status

PARAMETER	CONDITIONS	FREQUENCY (kHz)	DIGITAL READ-OUT
ADC word at I ² C-bus during read operation	input voltage at pin 10: 0.0 to 0.15V _S	–125	00
	input voltage at pin 10: 0.15 to 0.30V _S	–62.5	01
	input voltage at pin 10: 0.30 to 0.45V _S	0	02
	input voltage at pin 10: 0.45 to 0.60V _S	+62.5	03
	input voltage at pin 10: 0.60 to 1.00V _S	+125	04

**Desktop video tuner
system CCIR B/G**

FI1216MK2

APPLICATION INFORMATION

A detailed description of the I²C-bus specification, with applications, is given in brochure "The I²C-bus and how to use it". This brochure may be ordered using the code number 9398 393 40011.

WRITE mode

BYTE	BITS								
	7 MSB	6	5	4	3	2	1	0 LSB	A ⁽¹⁾
Address byte	1	1	0	0	0	MA1	MA0	0	A
Program divider byte 1	0	n14	n13	n12	n11	n10	n9	n8	A
Program divider byte 2	n7	n6	n5	n4	n3	n2	n1	n0	A
Control information byte 1	1	CP	T2	T1	T0	RSA	RSB	OS	A
Control information byte 2	P7	P6	P5	P4	P3	P2	P1	P0	A

Note

- 1. A = Acknowledge.

ADDRESS SELECTION

V_S = +5 V (PLL supply voltage).

MA1	MA0	ADDRESS	VOLTAGE AT PIN 15
0	0	C0	0.0V _S to 0.1V _S
0	1	C2	0.2V _S to 0.3V _S
1	0	C4	0.4V _S to 0.6V _S
1	1	C6	0.9V _S to 1.0V _S

PROGRAMMABLE DIVIDER SETTINGS (BYTES 1 AND 2)

Divider ratio:

$$N = 16 \times \{f_{RF(pc)} + f_{IF(pc)}\}, \text{ where (pc) is picture carrier and } f_{RF} \text{ and } f_{IF} \text{ are expressed in MHz}$$

$$f_{osc} = N/16 \text{ (MHz).}$$

$$N = (8192 \times n13) + (4096 \times n12) + (2048 \times n11) + (1024 \times n10) + (512 \times n9) + (256 \times n8) + (128 \times n7) + (64 \times n6) + (32 \times n5) + (16 \times n4) + (8 \times n3) + (4 \times n2) + (2 \times n1) + n0$$

CONTROL BYTE

Charge pump settings:

- CP = 1, for fast tuning
- CP = 0, for moderate speed tuning with slightly better residual oscillator FM.

Test mode settings:

- T2 = T1 = 0; T0 = 1, for normal operation.

PLL disabling:

- OS = 0, for normal operation
- OS = 1, for switching the charge pump to the high impedance state.

Desktop video tuner system CCIR B/G

FI1216MK2

Ratio select bits

RSA	RSB	STEP SIZE
X	0	50 kHz
0	1	31.25 kHz (for slow picture search)
1	1	62.5 kHz (for normal picture search)

PORTS BYTE

Band switching

BAND	BIT ⁽¹⁾							
	P0	P1	P2	P3 ⁽²⁾	P4	P5	P6	P7
Low band	0	0	0	X	0	1	0	1
Mid band	0	0	0	X	1	0	0	1
High band	0	0	0	X	1	1	0	0

Notes

1. X = don't care; P0 to P7 are output ports on the PLL device.
2. P3 is a system switch output for customer applications.

TELEGRAM EXAMPLES (WRITE MODE)

Start - Adb - Ack - Db1 - Ack - Db2 - Ack - Cb - Ack - Pb - Ack - Stop.

Start - Adb - Ack - Cb - Ack - Pb - Ack - Db1 - Ack - Db2 - Ack - Stop.

Start - Adb - Ack - Db1 - Ack - Db2 - Ack - Cb - Ack - Stop.

Start - Adb - Ack - Db1 - Ack - Db2 - Ack - Stop.

Where:

- Start = start condition
- Adb = address byte
- Ack = acknowledge
- Db1 = divider byte 1
- Db2 = divider byte 2
- Cb = control byte
- Pb = ports byte
- Stop = stop condition.

Remark: for channel selection involving band switching, and to ensure smooth tuning to the desired channel without causing unnecessary charge pump action, it is recommended to consider the difference between wanted channel frequency (f_w) and the current channel frequency (f_c):

- If $f_w > f_c$, use telegram as:
Start - Adb - Ack - Db1 - Ack - Db2 - Ack - Cb - Ack - Pb - Ack - Stop.
- If $f_w < f_c$, use telegram as:
Start - Adb - Ack - Cb - Ack - Pb - Ack - Db1 - Ack - Db2 - Ack - Stop.

Unnecessary charge pump action will result in very low tuning voltage ($V_T \approx 0$ V) which may drive the oscillator to extreme conditions.

**Desktop video tuner
system CCIR B/G**

FI1216MK2

READ mode

The in-lock can be read by setting the R/W bit to 1.

BYTE	BITS								
	7 MSB	6	5	4	3	2	1	0 LSB	A ⁽⁵⁾
Address byte	1	1	0	0	0	MA1	MA0	1	A
Status byte	POR ⁽¹⁾	FL ⁽²⁾	I2 ⁽³⁾	I1 ⁽³⁾	I0 ⁽³⁾	A2 ⁽⁴⁾	A1 ⁽⁴⁾	A0 ⁽⁴⁾	A

Notes

1. POR = Power On Reset. POR is internally set to 1 in case V_S drops below 3 V. The POR bit is reset when an end of data is detected by the PLL IC.
2. FL = In-lock flag; FL = 1: loop is phase-locked. The loop must be phase-locked during at least 8 periods of the internal 7.8125 kHz reference frequency before the FL flag is internally set to 1.
3. I2, I1 and I0 = digital information for I/O ports P2, P1 and P0 respectively.
4. A2, A1 and A0 = built-in 5-level A/D converter on I/O port P6. AFC information to the controller of the IF section is available on pin 10 (see Table "Digital AFC status").
5. A = Acknowledge.

TELEGRAM EXAMPLES (READ MODE)

Start - Adb - Ack - STB - Ack - STB - - Stop (no Ack from processor = End-of-data).

Start - Adb - Ack - STB - - Stop (no Ack from processor = End-of-data).

Where:

STB = Status byte.

Video buffer

A video buffer is built into the video module to enable the unit to drive a 75 Ω load directly. In case it is required to use the FI1216MK2 as a replacement for the FI1216 in the same videocard, it is necessary to replace the 75 Ω series resistor in the video card by a 0 Ω series resistor. At the same time the 22 k Ω series resistor in the tuning supply must be removed.

I²C-bus load

The FI1216MK2 contains a series resistor ($R = 100 \Omega$) in the SCL and SDA lines. Both lines also have a capacitive load of typical 56 pF (see Fig.3).

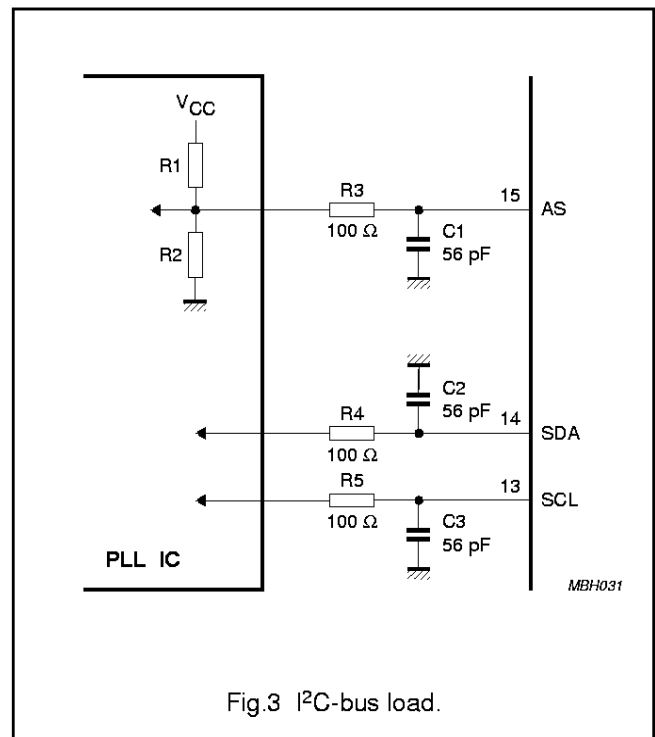
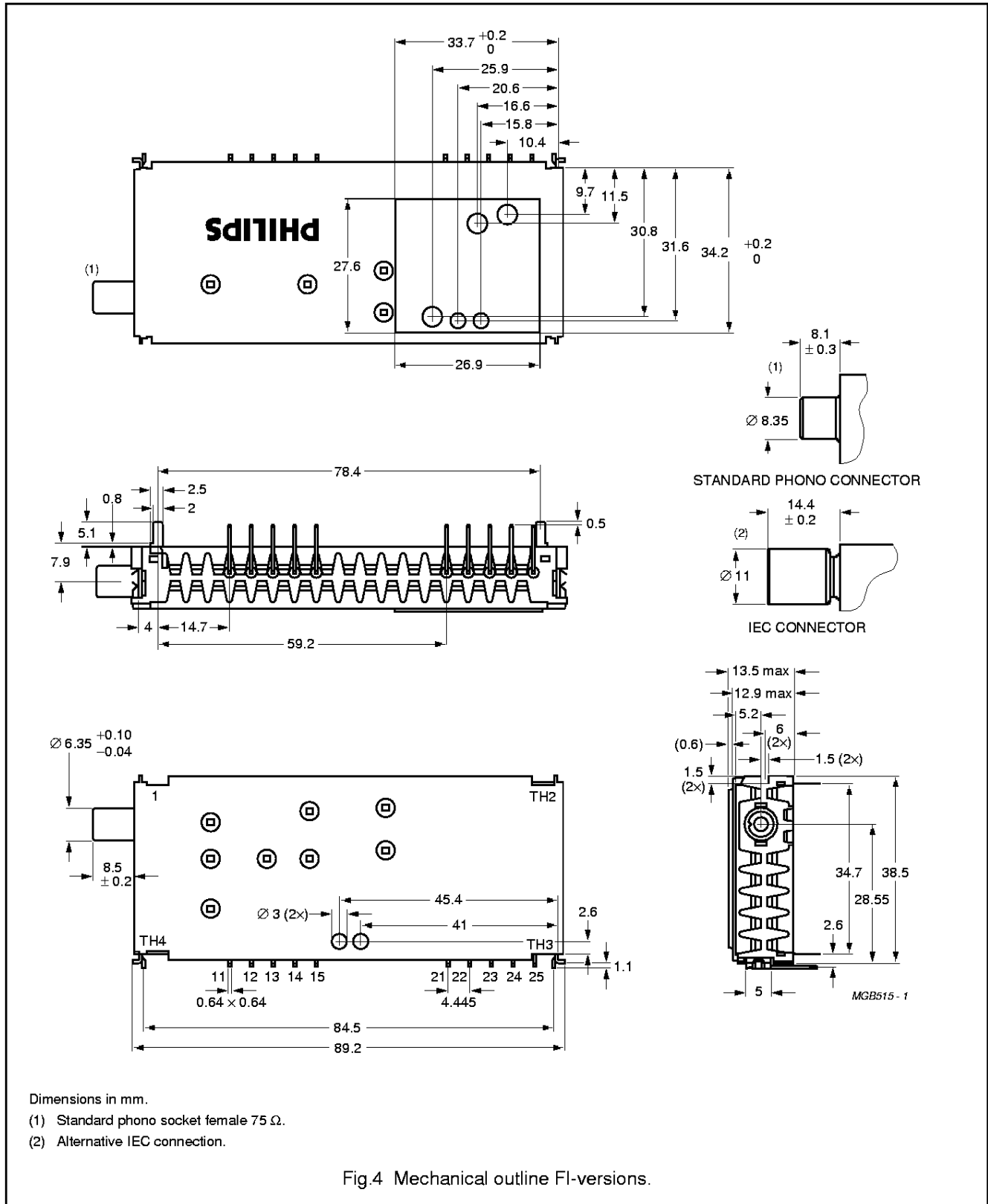

Fig.3 I²C-bus load.

Desktop video tuner
system CCIR B/G

FI1216MK2

MECHANICAL DATA



Desktop video tuner
system CCIR B/G

F11216MK2

Aerial connections

Standard-phono socket female 75 Ω or IEC (female).

Solderability

The solderability of pins and mounting tags when tested initially and after 16 hours steam ageing in accordance with "IEC 68-2-20", test Ta, method 1 (solder bath 235 °C for 2 s), results in a wetted area of 95%. No de-wetting will occur when soldered at 260 °C for 5 s.

Resistance to soldering heat

The product will not be damaged when tested in accordance with "IEC 68-2-20", test Tb, method 1A (solder bath 260 °C for 10 ± 1 s).

Mass

Approximately 50 g.

Robustness of pins

The pins will not be damaged when tested in accordance with "IEC 68-2-21":

- Test Ua1, tensile of 10 N in axial direction
- Test Ua2, thrust of 4 N in axial direction.

Punching pattern of chassis PCB

Field rejects are often related to broken tag joints. Therefore, the following punching pattern is recommended (see Fig.5).

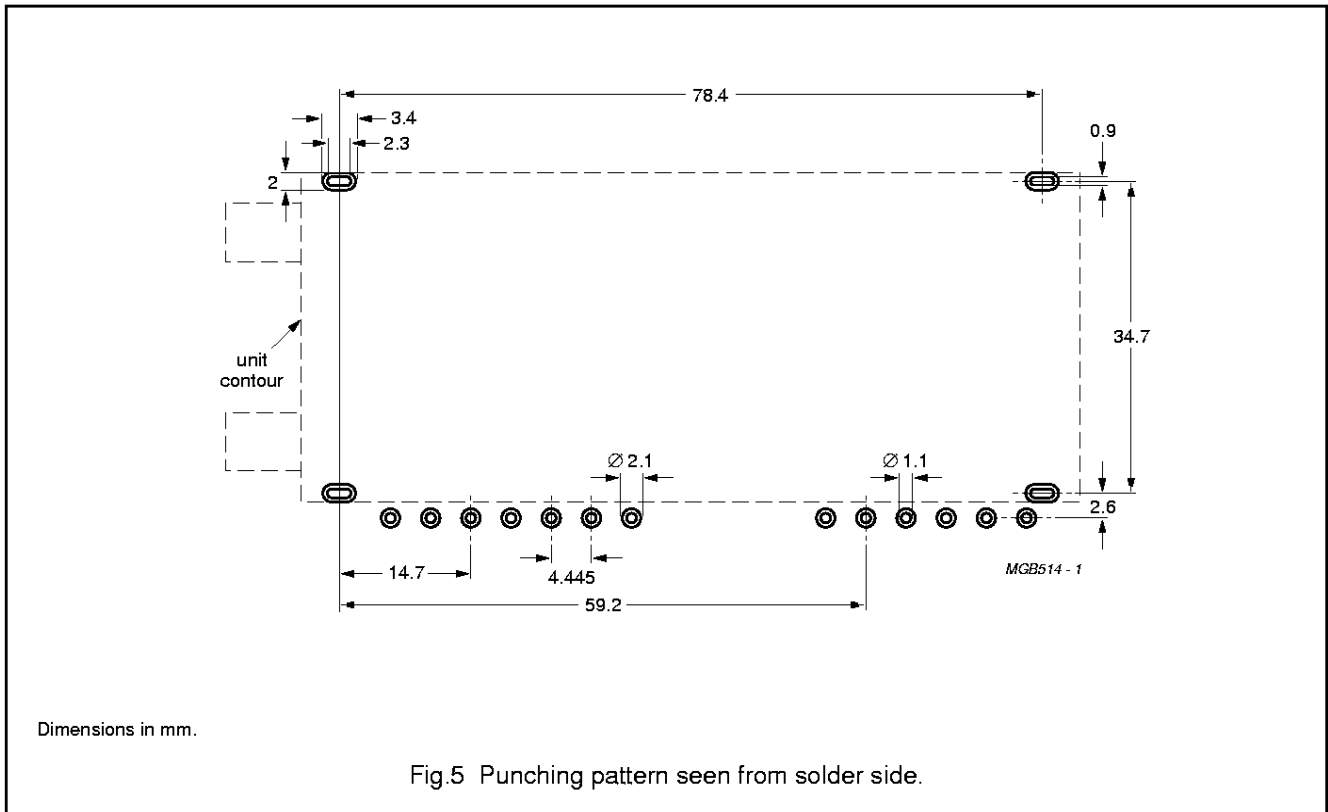

Fig.5 Punching pattern seen from solder side.

Desktop video tuner system CCIR B/G

FI1216MK2

TV CHANNEL FREQUENCIES (MHz)

CCIR cable

Vision IF = 38.90 MHz; sound IF = 33.40 MHz.

CHANNEL	FREQ. RANGE	PICTURE CARRIER FREQUENCY	SOUND CARRIER FREQUENCY
E2	47-54	48.25	53.75
E3	54-61	55.25	60.75
E4	61-68	62.25	67.75
S01	68-75	69.25	74.75
S02	75-82	76.25	81.75
S03	82-89	83.25	88.75
S1	104-111	105.25	110.75
S2	111-118	112.25	117.75
S3	118-125	119.25	124.75
S4	125-132	126.25	131.75
S5	132-139	133.25	138.75
S6	139-146	140.25	145.75
S7	146-153	147.25	152.75
S8	153-160	154.25	159.75
S9	160-167	161.25	166.75
S10	167-174	168.25	173.75
E5	174-181	175.25	180.75
E6	181-188	182.25	187.75
E7	188-195	189.25	194.75
E8	195-202	196.25	201.75
E9	202-209	203.25	208.75
E10	209-216	210.25	215.75
E11	216-223	217.25	222.75
E12	223-230	224.25	229.75
S11	230-237	231.25	236.75
S12	237-244	238.25	243.75
S13	244-251	245.25	250.75
S14	251-258	252.25	257.75

CHANNEL	FREQ. RANGE	PICTURE CARRIER FREQUENCY	SOUND CARRIER FREQUENCY
S15	258-265	259.25	264.75
S16	265-272	266.25	271.75
S17	272-279	273.25	278.75
S18	279-286	280.25	285.75
S19	286-293	287.25	292.75
S20	293-300	294.25	299.75
S21	302-310	303.25	308.75
S22	310-318	311.25	316.75
S23	318-326	319.25	324.75
S24	326-334	327.25	332.75
S25	334-342	335.25	340.75
S26	342-350	343.25	348.75
S27	350-358	351.25	356.75
S28	358-366	359.25	364.75
S29	366-374	367.25	372.75
S30	374-382	375.25	380.75
S31	382-390	383.25	388.75
S32	390-398	391.25	396.75
S33	398-406	399.25	404.75
S34	406-414	407.25	412.75
S35	414-422	415.25	420.75
S36	422-430	423.25	428.75
S37	430-438	431.25	436.75
S38	438-446	439.25	444.75
S39	446-454	447.25	452.75
S40	454-462	455.25	460.75
S41	462-470	463.25	468.75

Desktop video tuner system CCIR B/G

FI1216MK2

CCIR B/G

Vision IF = 38.90 MHz; sound IF = 33.40 MHz.

CHANNEL	FREQ. RANGE	PICTURE CARRIER FREQUENCY	SOUND CARRIER FREQUENCY
2	47-54	48.25	53.75
3	54-61	55.25	60.75
4	61-68	62.25	67.75
5	174-181	175.25	180.75
6	181-188	182.25	187.75
7	188-195	189.25	194.75
8	195-202	196.25	201.75
9	202-209	203.25	208.75
10	209-216	210.25	215.75
11	216-223	217.25	222.75
12	223-230	224.25	229.75
21	470-478	471.25	476.75
22	478-486	479.25	484.75
23	486-494	487.25	492.75
24	494-502	495.25	500.75
25	502-510	503.25	508.75
26	510-518	511.25	516.75
27	518-526	519.25	524.75
28	526-534	527.25	532.75
29	534-542	535.25	540.75
30	542-550	543.25	548.75
31	550-558	551.25	556.75
32	558-566	559.25	564.75
33	566-574	567.25	572.75
34	574-582	575.25	580.75
35	582-590	583.25	588.75
36	590-598	591.25	596.75
37	598-606	599.25	604.75
38	606-614	607.25	612.75
39	614-622	615.25	620.75

CHANNEL	FREQ. RANGE	PICTURE CARRIER FREQUENCY	SOUND CARRIER FREQUENCY
40	622-630	623.25	628.75
41	630-638	631.25	636.75
42	638-646	639.25	644.75
43	646-654	647.25	652.75
44	654-662	655.25	660.75
45	662-670	663.25	668.75
46	670-678	671.25	676.75
47	678-686	679.25	684.75
48	686-694	687.25	692.75
49	694-702	695.25	700.75
50	702-710	703.25	708.75
51	710-718	711.25	716.75
52	718-726	719.25	724.75
53	726-734	727.25	732.75
54	734-742	735.25	740.75
55	742-750	743.25	748.75
56	750-758	751.25	756.75
57	758-766	759.25	764.75
58	766-774	767.25	772.75
59	774-782	775.25	780.75
60	782-790	783.25	788.75
61	790-798	791.25	796.75
62	798-806	799.25	804.75
63	806-814	807.25	812.75
64	814-822	815.25	820.75
65	822-830	823.25	828.75
66	830-838	831.25	836.75
67	838-846	839.25	844.75
68	846-854	847.25	852.75
69	854-862	855.25	860.75

Desktop video tuner system CCIR B/G

FI1216MK2

Italy

Vision IF = 38.90 MHz; sound IF = 33.40 MHz.

CHANNEL	PICTURE CARRIER FREQUENCY	SOUND CARRIER FREQUENCY
A	53.75	59.25
B	62.25	67.75
C	82.25	87.75
D	175.25	180.75
E	183.75	189.25
F	197.25	192.75
G	201.25	206.75
H	210.25	215.75
H1	217.25	222.75
H2	224.25	229.75

DEFINITIONS

Data sheet status	
Objective specification	This data sheet contains target or goal specifications for product development.
Preliminary specification	This data sheet contains preliminary data; supplementary data may be published later.
Product specification	This data sheet contains final product specifications.
Application information	
Where application information is given, it is advisory and does not form part of the specification.	

LIFE SUPPORT APPLICATIONS

These products are not designed for use in life support appliances, devices, or systems where malfunction of these products can reasonably be expected to result in personal injury. Philips customers using or selling these products for use in such applications do so at their own risk and agree to fully indemnify Philips for any damages resulting from such improper use or sale.

PURCHASE OF PHILIPS I²C COMPONENTS

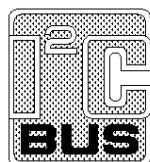

Purchase of Philips I²C components conveys a license under the Philips' I²C patent to use the components in the I²C system provided the system conforms to the I²C specification defined by Philips. This specification can be ordered using the code 9398 393 40011.

Philips Components – a worldwide company

Argentina: Ierod, BUENOS AIRES,
Tel. (01) 786 7635, Fax. (01) 786 9397.

Australia: Philips Components Pty Ltd, NORTH RYDE,
Tel. (02) 9805 4455, Fax. (02) 9805 4466.

Austria: Österreichische Philips Industrie GmbH, WIEN,
Tel. (01) 601 01 12 41, Fax. (01) 60 101 12 11.

Belarus: Philips Office Belarus, MINSK,
Tel. (5172) 200 915, Fax. (5172) 200 773.

Benelux: Philips Nederland B.V., EINDHOVEN, NL.,
Tel. (+31 40) 2783 749, Fax. (+31 40) 2788 399.

Brazil: Philips Components, SÃO PAULO,
Tel. (011) 821 2333, Fax. (011) 829 1849.

Canada: Philips Electronics Ltd., SCARBOROUGH,
Tel. (0416) 292 5161, Fax. (0416) 754 6248.

China: Philips Company, SHANGHAI,
Tel. (021) 6485 0600, Fax. (021) 6485 5615.

Colombia: Iprelensó Ltda, SANTAFE DE BOGOTA,
Tel. (01) 345 8713, Fax. (01) 345 8712.

Denmark: Philips Components A/S, COPENHAGEN S,
Tel. (32) 883 333, Fax. (31) 571 949.

Finland: Philips Components, ESPOO,
Tel. 9 (0)-615 800, Fax. 9 (0)-615 80510.

France: Philips Composants, SURESNES,
Tel. (01) 4099 6161, Fax. (01) 4099 6427.

Germany: Philips Components GmbH, HAMBURG,
Tel. (040) 2489-0, Fax. (040) 2489 1400.

Greece: Philips Hellas S.A., TAVROS,
Tel. (01) 4894 339/(01) 4894 239, Fax. (01) 4814 240.

Hong Kong: Philips Hong Kong, KOWLOON,
Tel. 2784 3000, Fax. 2784 3003.

India: Philips India Ltd., BOMBAY,
Tel. (022) 4938 541, Fax. (022) 4938 722.

Indonesia: P.T. Philips Development Corp., JAKARTA,
Tel. (021) 520 1122, Fax. (021) 520 5189.

Ireland: Philips Electronics (Ireland) Ltd., DUBLIN,
Tel. (01) 76 40 203, Fax. (01) 76 40 210.

Israel: Rapac Electronics Ltd., TEL AVIV,
Tel. (03) 6450 444, Fax. (03) 6491 007.

Italy: Philips Components S.r.l., MILANO,
Tel. (02) 6752 2531, Fax. (02) 6752 2557.

Japan: Philips Japan Ltd., TOKYO,
Tel. (03) 3740 5028, Fax. (03) 3740 0580.

Korea (Republic of): Philips Electronics (Korea) Ltd., SEOUL,
Tel. (02) 709 -1472, Fax. (02) 709 1480.

Malaysia: Philips Malaysia SDN Berhad
Components Division, PULAU PINANG,
Tel. (04) 657 0055, Fax. (04) 656 5951.

Mexico: Philips Components, EL PASO, U.S.A.,
Tel. (915) 772 4020, Fax. (915) 772 4332.

New Zealand: Philips New Zealand Ltd., AUCKLAND,
Tel. (09) 849 4160, Fax. (09) 849 7811.

Norway: Norsk A/S Philips, OSLO,
Tel. (22) 74 8000, Fax. (22) 74 8341.

Pakistan: Philips Electrical Industries of Pakistan Ltd., KARACHI,
Tel. (021) 587 4641-49, Fax. (021) 577 035/587 4546.

Philippines: Philips Semiconductors Philippines Inc.,
METRO MANILA, Tel. (02) 816 6380, Fax. (02) 817 3474.

Poland: Philips Poland Sp. z.o.o., WARSZAWA,
Tel. (022) 612 2594, Fax. (022) 612 2327.

Portugal: Philips Portuguesa S.A.,
Philips Components: LINDA-A-VELHA,
Tel. (01) 416 3160/416 3333, Fax. (01) 416 3174/416 3366.

Russia: Philips Russia, MOSCOW,
Tel. (095) 247 9124, Fax. (095) 247 9132.

Singapore: Philips Singapore Pte Ltd., SINGAPORE,
Tel. 350 2000, Fax. 355 1758.

South Africa: S.A. Philips Pty Ltd., JOHANNESBURG,
Tel. (011) 470 5911, Fax. (011) 470 5494.

Spain: Philips Components, BARCELONA,
Tel. (93) 301 63 12, Fax. (93) 301 42 43.

Sweden: Philips Components AB, STOCKHOLM,
Tel. (+46) 8 632 2000, Fax. (+46) 8 632 2745.

Switzerland: Philips Components AG, ZÜRICH,
Tel. (01) 488 22 11, Fax. (01) 481 77 30.

Taiwan: Philips Taiwan Ltd., TAIPEI,
Tel. (02) 388 7666, Fax. (02) 382 4382.

Thailand: Philips Electronics (Thailand) Ltd., BANGKOK,
Tel. (02) 745 4090, Fax. (02) 398 0793.

Turkey: Türk Philips Ticaret A.S., GÜLTEPE/ISTANBUL,
Tel. (0212) 279 2770, Fax. (0212) 282 6707.

Ukraine: Philips Ukraine Ltd., KIEV,
Tel. (044) 268 7327, Fax. (044) 268 6323.

United Kingdom: Philips Components Ltd., DORKING,
Tel. (01306) 512 000, Fax. (01306) 512 345.

United States:

- Philips Components, JUPITER, FL,
Tel. (561) 745 3300, Fax. (561) 745 3600.
- For literature: (800) 447 3762.
- Display and Wire Wound Components, ANN ARBOR, MI,
Tel. (313) 996 9400, Fax. (313) 761 2776.
- Magnetic Products, SAUGERTIES, NY,
Tel. (914) 246 2811, Fax. (914) 246 0487.

Uruguay: Philips Components, MONTEVIDEO,
Tel. (02) 704 044, Fax. (02) 920 601.

For all other countries apply to: Philips Components,
Marketing Communications, P.O. Box 218, 5600 MD EINDHOVEN,
The Netherlands, Fax. +31-40-2724 547.

COD11 © Philips Electronics N.V. 1997

All rights are reserved. Reproduction in whole or in part is prohibited without the prior written consent of the copyright owner.
The information presented in this document does not form part of any quotation or contract, is believed to be accurate and reliable and may be changed without notice. No liability will be accepted by the publisher for any consequence of its use. Publication thereof does not convey nor imply any license under patent- or other industrial or intellectual property rights.

Printed in The Netherlands

Let's make things better.

**Philips
Components**



PHILIPS