

November 1989
Edition 1.0

PRODUCT PROFILE

MB767

Octal TTL to ECL Level Translator with Strobe

DESCRIPTION

The Fujitsu MB767 is a high-speed TTL-to-ECL level translator with eight circuits. The MB767 ECL input interface is compatible with 10KH ECL. The MB767 is housed in a 20-pin plastic or ceramic dual in-line package, 22-pin PLCC, and 24-pin ceramic LCC.

FEATURES

- High speed switching:
Propagation delay time: 1.6 ns (typ.)
- Strobe input: As TTL level strobe input changes to Low, all outputs change to Low.
- High-density mounting:
Eight circuits per package.
- Input interface level: Compatible with 10KH ECL.
- Power supply voltage: 5.0 V (V_{CC}) and -5.2 V (V_{EE}), which are typical for TTL and ECL. Switching on and off can be done with either V_{CC} or V_{EE} .

ABSOLUTE MAXIMUM RATINGS

$T_A = 25^\circ\text{C}$

Parameter	Symbol	Rating	Unit
Power Supply Voltage	V_{CC}	0 to +7.0	V
Power Supply Voltage	V_{EE}	-7.0 to 0	V
Input Voltage	V_I	-0.5 to +5.5	V
Input Current	I_I	-18 to 0	mA
Output Voltage	V_O	-0.5 to +5.5	V
Output Current	I_{OUT}	-40 to 0	mA
Operating Ambient Temperature	T_A	-10 to +125	$^\circ\text{C}$
Storage Temperature	T_{STG}	-55 to +150	$^\circ\text{C}$

RECOMMENDED OPERATING CONDITIONS

Parameter	Symbol	Rating	Unit
Power Supply Voltage	V_{CC}	$+5.0 \pm 10\%$	V
Power Supply Voltage	V_{EE}	$-5.2 \pm 10\%$	V
Output Termination Resistor	R_T	50	Ω
Output Termination Voltage	V_T	$-2.0 \pm 10\%$	V
Input Voltage	V_I	0 to V_{CC}	V
Operating Ambient Temperature	T_A	0 to +75	$^\circ\text{C}$

NOTE: Permanent device damage may occur if absolute maximum ratings are exceeded. Functional operation should be restricted to the conditions as detailed in the operation sections of this data sheet. Exposure to absolute maximum rating conditions for extended periods may affect device reliability.

H: High level
L: Low Level
x: Don't care

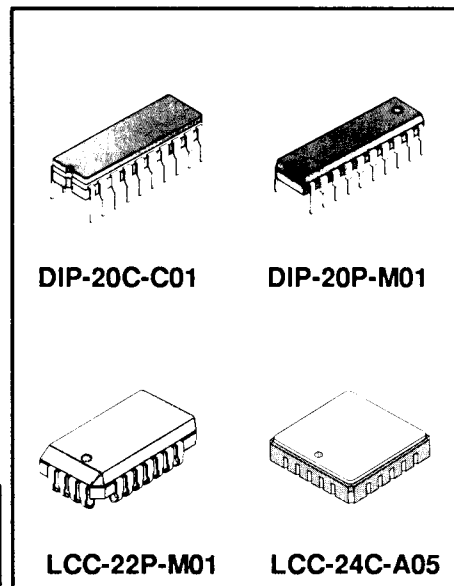

PIN ASSIGNMENT (TOP VIEW) 20 Pin DIP*

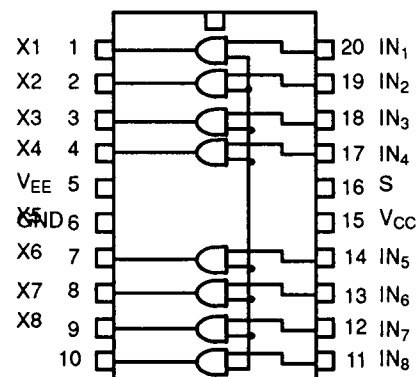

INPUT: IN_1 to IN_8 = ECL level input
S = Strobe input (TTL level)
OUTPUT: X_1 to X_8 = TTL level output
*PLCC and LCC pinouts are shown in the complete data sheet

TRUTH TABLE

Input		Output
IN_n (TTL)	S (TTL)	X_n (ECL)
H	H	H
L	H	L
x	L	L