



REMOTE CONTROL COMMANDER IC

■ GENERAL DESCRIPTION

The NJU6015 is a remote control commander IC, and generates the control code according to the key input of 8 x 8 matrix. It contains auto clear circuit, carrier generator, key input / key scan output circuit, extension code generator, data ROM and operated single power supply.

The NJU6015 has the stand-by mode using auto clear function with external capacitance.

The transmission code is using a Pulse Position Modulation (PPM) method and its transmission by the IR-LED. Maximum 80 - pattern output is available by programming the PLA and custom code ROM.

■ PACKAGE OUTLINE

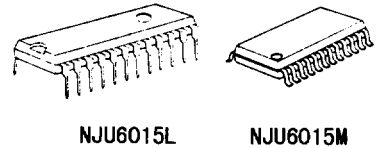

■ FEATURES

- Transmission Code    -- Pulse Position Modulation
- Generating Pattern    -- Fixed by PLA and ROM
- Frame Number Setting -- 1 to 8 frame
- Internal Oscillation Circuit
- Power On Initialization
- Stand-by Mode        -- 1  $\mu$ A Max.
- Low Power Consumption
- Low Operating Voltage -- 1.1 ~ 1.8V
- Package Outline      -- DMP / SDIP 24
- C-MOS Technology

■ PIN CONFIGURATION

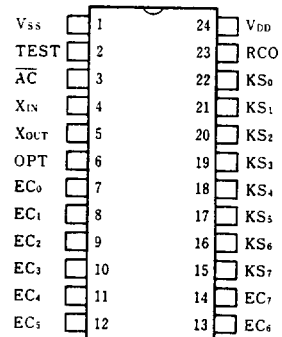

■ BLOCK DIAGRAM

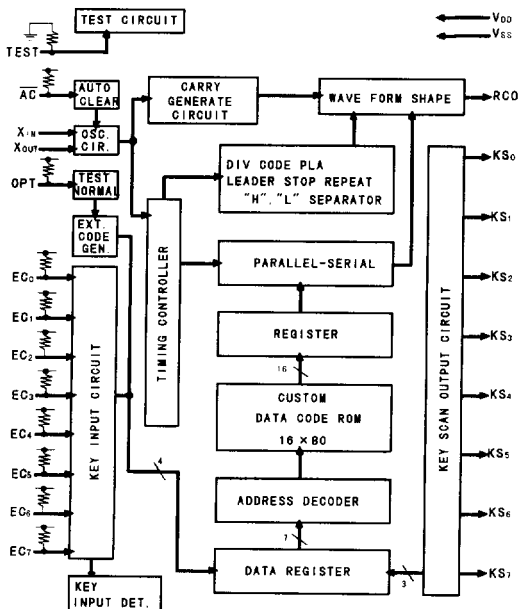

**■ TERMINAL DESCRIPTION**

NO.	SYMBOL	FUNCTION
1	V <sub>SS</sub>	GND
2	TEST	Testing Terminal (Normally OPEN, Internal Pull-down Resistance)
3	AC	Auto Clear Terminal (Internal Pull-up Resistance) Power on initialization is executed by connecting a capacitance to this.
4, 5	X <sub>IN</sub> , X <sub>OUT</sub>	Oscillation Inverter Input / Output Terminal (Internal Feedback Resistance) This connects a ceramic resonator.
6	OPT	Extension Key Input Terminal (Internal Pull-up Resistance) The keys are extended by connecting with switches between the OPT terminal and the key scan terminals KS <sub>6</sub> and KS <sub>7</sub> .
7~14	EC <sub>0</sub> ~EC <sub>7</sub>	Key Matrix Input Terminal (Internal Pull-up Resistance) The RCO output is started when this key input is perceived after 36msec period.
15~22	KS <sub>7</sub> ~KS <sub>0</sub>	Key Scan Output Terminal Key scan time is 0.42msec. In case using maximum 32 keys, all scan time is about 36msec in high speed.
23	RCO	Remote Control Oscillation Terminal The pulse line of the transmission cord modulated by carrier wave is output. This pulse operates the IR-LED by driving the base of an external NPN transistor.
24	V <sub>DD</sub>	Power Supply Voltage range is wide from 1.1V to 1.8V, therefore it is single battery (1.5V) enough to operate. Except for key operation, operating current (stand-by current) is dropped under 1uA by stopping oscillation.

10

**■ FUNCTIONAL DESCRIPTION**
**(1) Oscillation Circuit**

The NJU6015 incorporates an internal oscillation circuit, therefore, when a ceramic resonator is connected the terminals X<sub>IN</sub> and X<sub>OUT</sub>, carrier wave of a transmission signal is generated inside.

**(2) Key Matrix**

The key of 8×8 matrix consists the inputs EC<sub>0</sub> to EC<sub>7</sub> and the key scan outputs KS<sub>0</sub> to KS<sub>7</sub>. And Keys are extended by combining the OPT terminal and the terminals KS<sub>6</sub> and KS<sub>7</sub>.

**(3) Transmission Signal**
**(3-1) Data Format**

The NJU6015 has 14 kinds of the data transmission format as shown in Table 1.



Table 1 Data Transmission Format in NJU6015

Wave Type	Date Line Up																																														
1	<table border="1"> <tr> <td colspan="2">Custom Code 8bit</td> <td colspan="2">Custom Code 8bit</td> <td colspan="2">Data Code 8bit</td> <td colspan="2">Data Code 8bit</td> </tr> <tr> <td>Leader</td><td>C1</td><td>C2</td><td>C3</td><td>C4</td><td>C5</td><td>C6</td><td>C7</td><td>C8</td><td>C1</td><td>C2</td><td>C3</td><td>C4</td><td>C5</td><td>C6</td><td>C7</td><td>C8</td><td>D1</td><td>D2</td><td>D3</td><td>D4</td><td>D5</td><td>D6</td><td>D7</td><td>D8</td><td>D1</td><td>D2</td><td>D3</td><td>D4</td><td>D5</td><td>D6</td><td>D7</td><td>D8</td><td>Stop</td><td>Repeat</td> </tr> </table>	Custom Code 8bit		Custom Code 8bit		Data Code 8bit		Data Code 8bit		Leader	C1	C2	C3	C4	C5	C6	C7	C8	C1	C2	C3	C4	C5	C6	C7	C8	D1	D2	D3	D4	D5	D6	D7	D8	D1	D2	D3	D4	D5	D6	D7	D8	Stop	Repeat			
Custom Code 8bit		Custom Code 8bit		Data Code 8bit		Data Code 8bit																																									
Leader	C1	C2	C3	C4	C5	C6	C7	C8	C1	C2	C3	C4	C5	C6	C7	C8	D1	D2	D3	D4	D5	D6	D7	D8	D1	D2	D3	D4	D5	D6	D7	D8	Stop	Repeat													
2	<table border="1"> <tr> <td colspan="2">Custom Code 8bit</td> <td colspan="2">Data Code 8bit</td> </tr> <tr> <td>Leader</td><td>C1</td><td>C2</td><td>C3</td><td>C4</td><td>C5</td><td>C6</td><td>C7</td><td>C8</td><td>D1</td><td>D2</td><td>D3</td><td>D4</td><td>D5</td><td>D6</td><td>D7</td><td>D8</td><td>Stop</td> </tr> </table>	Custom Code 8bit		Data Code 8bit		Leader	C1	C2	C3	C4	C5	C6	C7	C8	D1	D2	D3	D4	D5	D6	D7	D8	Stop																								
Custom Code 8bit		Data Code 8bit																																													
Leader	C1	C2	C3	C4	C5	C6	C7	C8	D1	D2	D3	D4	D5	D6	D7	D8	Stop																														
3	<table border="1"> <tr> <td colspan="2">Data Code 8bit</td> </tr> <tr> <td>D1</td><td>D2</td><td>D3</td><td>D4</td><td>D5</td><td>D6</td><td>Stop</td> </tr> </table>	Data Code 8bit		D1	D2	D3	D4	D5	D6	Stop																																					
Data Code 8bit																																															
D1	D2	D3	D4	D5	D6	Stop																																									
4	<table border="1"> <tr> <td colspan="2">Data Code 10bit</td> </tr> <tr> <td>D1</td><td>2</td><td>3</td><td>4</td><td>5</td><td>6</td><td>7</td><td>8</td><td>9</td><td>10</td><td>Stop</td> </tr> </table>	Data Code 10bit		D1	2	3	4	5	6	7	8	9	10	Stop																																	
Data Code 10bit																																															
D1	2	3	4	5	6	7	8	9	10	Stop																																					
5	<table border="1"> <tr> <td colspan="2">Custom Code 8bit</td> <td colspan="2">Custom Code 8bit</td> <td colspan="2">Data Code 8bit</td> <td colspan="2">Data Code 8bit</td> </tr> <tr> <td>Leader</td><td>C1</td><td>C2</td><td>C3</td><td>C4</td><td>C5</td><td>C6</td><td>C7</td><td>C8</td><td>C1</td><td>C2</td><td>C3</td><td>C4</td><td>C5</td><td>C6</td><td>C7</td><td>C8</td><td>D1</td><td>D2</td><td>D3</td><td>D4</td><td>D5</td><td>D6</td><td>D7</td><td>D8</td><td>D1</td><td>D2</td><td>D3</td><td>D4</td><td>D5</td><td>D6</td><td>D7</td><td>D8</td><td>Stop</td> </tr> </table>	Custom Code 8bit		Custom Code 8bit		Data Code 8bit		Data Code 8bit		Leader	C1	C2	C3	C4	C5	C6	C7	C8	C1	C2	C3	C4	C5	C6	C7	C8	D1	D2	D3	D4	D5	D6	D7	D8	D1	D2	D3	D4	D5	D6	D7	D8	Stop				
Custom Code 8bit		Custom Code 8bit		Data Code 8bit		Data Code 8bit																																									
Leader	C1	C2	C3	C4	C5	C6	C7	C8	C1	C2	C3	C4	C5	C6	C7	C8	D1	D2	D3	D4	D5	D6	D7	D8	D1	D2	D3	D4	D5	D6	D7	D8	Stop														
6	<table border="1"> <tr> <td colspan="2">Address 5</td> <td colspan="2">Data 6</td> <td>Option2</td> <td>Mask1</td> <td>Check1</td> <td colspan="2">Address 5</td> <td colspan="2">Data 6</td> <td>Option2</td> <td>Mask1</td> <td>Check1</td> </tr> <tr> <td>A1</td><td>A2</td><td>A3</td><td>A4</td><td>A5</td><td>D1</td><td>D2</td><td>D3</td><td>D4</td><td>D5</td><td>D6</td><td>D1</td><td>D2</td><td>M1</td><td>H1</td><td>Stop</td><td>A1</td><td>A2</td><td>A3</td><td>A4</td><td>A5</td><td>D1</td><td>D2</td><td>D3</td><td>D4</td><td>D5</td><td>D6</td><td>D1</td><td>D2</td><td>M1</td><td>H1</td><td>Stop</td> </tr> </table>	Address 5		Data 6		Option2	Mask1	Check1	Address 5		Data 6		Option2	Mask1	Check1	A1	A2	A3	A4	A5	D1	D2	D3	D4	D5	D6	D1	D2	M1	H1	Stop	A1	A2	A3	A4	A5	D1	D2	D3	D4	D5	D6	D1	D2	M1	H1	Stop
Address 5		Data 6		Option2	Mask1	Check1	Address 5		Data 6		Option2	Mask1	Check1																																		
A1	A2	A3	A4	A5	D1	D2	D3	D4	D5	D6	D1	D2	M1	H1	Stop	A1	A2	A3	A4	A5	D1	D2	D3	D4	D5	D6	D1	D2	M1	H1	Stop																
7	<table border="1"> <tr> <td colspan="2">Data Code 12bit</td> </tr> <tr> <td>D1</td><td>2</td><td>3</td><td>4</td><td>5</td><td>6</td><td>7</td><td>8</td><td>9</td><td>10</td><td>11</td><td>12</td><td>Stop</td> </tr> </table>	Data Code 12bit		D1	2	3	4	5	6	7	8	9	10	11	12	Stop																															
Data Code 12bit																																															
D1	2	3	4	5	6	7	8	9	10	11	12	Stop																																			
8	<table border="1"> <tr> <td colspan="2">Data Code 12bit</td> </tr> <tr> <td>Leader</td><td>D1</td><td>2</td><td>3</td><td>4</td><td>5</td><td>6</td><td>7</td><td>8</td><td>9</td><td>10</td><td>11</td><td>12</td><td>Stop</td> </tr> </table>	Data Code 12bit		Leader	D1	2	3	4	5	6	7	8	9	10	11	12	Stop																														
Data Code 12bit																																															
Leader	D1	2	3	4	5	6	7	8	9	10	11	12	Stop																																		
9	<table border="1"> <tr> <td colspan="2">Custom Code 8bit</td> <td colspan="2">Data Code 8bit</td> </tr> <tr> <td>Leader</td><td>C1</td><td>C2</td><td>C3</td><td>C4</td><td>C5</td><td>C6</td><td>C7</td><td>C8</td><td>Separator</td><td>D1</td><td>D2</td><td>D3</td><td>D4</td><td>D5</td><td>D6</td><td>D7</td><td>D8</td><td>Stop</td> </tr> </table>	Custom Code 8bit		Data Code 8bit		Leader	C1	C2	C3	C4	C5	C6	C7	C8	Separator	D1	D2	D3	D4	D5	D6	D7	D8	Stop																							
Custom Code 8bit		Data Code 8bit																																													
Leader	C1	C2	C3	C4	C5	C6	C7	C8	Separator	D1	D2	D3	D4	D5	D6	D7	D8	Stop																													
10	<table border="1"> <tr> <td colspan="2">Custom Code 8bit</td> <td colspan="2">Custom Code 8bit</td> <td colspan="2">Data Code 8bit</td> <td colspan="2">Data Code 8bit</td> </tr> <tr> <td>Leader</td><td>C1</td><td>C2</td><td>C3</td><td>C4</td><td>C5</td><td>C6</td><td>C7</td><td>C8</td><td>C1</td><td>C2</td><td>C3</td><td>C4</td><td>C5</td><td>C6</td><td>C7</td><td>C8</td><td>D1</td><td>D2</td><td>D3</td><td>D4</td><td>D5</td><td>D6</td><td>D7</td><td>D8</td><td>D1</td><td>D2</td><td>D3</td><td>D4</td><td>D5</td><td>D6</td><td>D7</td><td>D8</td><td>Stop</td><td>Repeat</td> </tr> </table>	Custom Code 8bit		Custom Code 8bit		Data Code 8bit		Data Code 8bit		Leader	C1	C2	C3	C4	C5	C6	C7	C8	C1	C2	C3	C4	C5	C6	C7	C8	D1	D2	D3	D4	D5	D6	D7	D8	D1	D2	D3	D4	D5	D6	D7	D8	Stop	Repeat			
Custom Code 8bit		Custom Code 8bit		Data Code 8bit		Data Code 8bit																																									
Leader	C1	C2	C3	C4	C5	C6	C7	C8	C1	C2	C3	C4	C5	C6	C7	C8	D1	D2	D3	D4	D5	D6	D7	D8	D1	D2	D3	D4	D5	D6	D7	D8	Stop	Repeat													
11	<table border="1"> <tr> <td colspan="2">Custom Code 8bit</td> <td colspan="2">Data Code 8bit</td> <td colspan="2">Custom Code 8bit</td> <td colspan="2">Data Code 8bit</td> </tr> <tr> <td>Leader</td><td>C1</td><td>C2</td><td>C3</td><td>C4</td><td>C5</td><td>C6</td><td>D1</td><td>D2</td><td>D3</td><td>D4</td><td>D5</td><td>D6</td><td>C1</td><td>C2</td><td>C3</td><td>C4</td><td>C5</td><td>C6</td><td>D1</td><td>D2</td><td>D3</td><td>D4</td><td>D5</td><td>D6</td><td>Stop</td> </tr> </table>	Custom Code 8bit		Data Code 8bit		Custom Code 8bit		Data Code 8bit		Leader	C1	C2	C3	C4	C5	C6	D1	D2	D3	D4	D5	D6	C1	C2	C3	C4	C5	C6	D1	D2	D3	D4	D5	D6	Stop												
Custom Code 8bit		Data Code 8bit		Custom Code 8bit		Data Code 8bit																																									
Leader	C1	C2	C3	C4	C5	C6	D1	D2	D3	D4	D5	D6	C1	C2	C3	C4	C5	C6	D1	D2	D3	D4	D5	D6	Stop																						
12	<table border="1"> <tr> <td colspan="2">Custom Code 5bit</td> <td colspan="2">Data Code 6bit</td> <td colspan="2">Custom Code 5bit</td> <td colspan="2">Data Code 6bit</td> </tr> <tr> <td>Leader</td><td>C1</td><td>C2</td><td>C3</td><td>C4</td><td>C5</td><td>D1</td><td>D2</td><td>D3</td><td>D4</td><td>D5</td><td>D6</td><td>C1</td><td>C2</td><td>C3</td><td>C4</td><td>C5</td><td>D1</td><td>D2</td><td>D3</td><td>D4</td><td>D5</td><td>D6</td><td>Stop</td> </tr> </table>	Custom Code 5bit		Data Code 6bit		Custom Code 5bit		Data Code 6bit		Leader	C1	C2	C3	C4	C5	D1	D2	D3	D4	D5	D6	C1	C2	C3	C4	C5	D1	D2	D3	D4	D5	D6	Stop														
Custom Code 5bit		Data Code 6bit		Custom Code 5bit		Data Code 6bit																																									
Leader	C1	C2	C3	C4	C5	D1	D2	D3	D4	D5	D6	C1	C2	C3	C4	C5	D1	D2	D3	D4	D5	D6	Stop																								
13	<table border="1"> <tr> <td colspan="2">Custom Code 8bit</td> <td colspan="2">Data Code 8bit</td> </tr> <tr> <td>C1</td><td>C2</td><td>C3</td><td>C4</td><td>C5</td><td>C6</td><td>C7</td><td>C8</td><td>D1</td><td>D2</td><td>D3</td><td>D4</td><td>D5</td><td>D6</td><td>D7</td><td>D8</td><td>Stop</td> </tr> </table>	Custom Code 8bit		Data Code 8bit		C1	C2	C3	C4	C5	C6	C7	C8	D1	D2	D3	D4	D5	D6	D7	D8	Stop																									
Custom Code 8bit		Data Code 8bit																																													
C1	C2	C3	C4	C5	C6	C7	C8	D1	D2	D3	D4	D5	D6	D7	D8	Stop																															
14	<table border="1"> <tr> <td colspan="2">Custom Code 8bit</td> <td colspan="2">Custom Code 8bit</td> <td colspan="2">Data Code 8bit</td> <td colspan="2">Data Code 8bit</td> </tr> <tr> <td>Leader</td><td>C1</td><td>C2</td><td>C3</td><td>C4</td><td>C5</td><td>C6</td><td>C7</td><td>C8</td><td>C1</td><td>C2</td><td>C3</td><td>C4</td><td>C5</td><td>C6</td><td>C7</td><td>C8</td><td>D1</td><td>D2</td><td>D3</td><td>D4</td><td>D5</td><td>D6</td><td>D7</td><td>D8</td><td>D1</td><td>D2</td><td>D3</td><td>D4</td><td>D5</td><td>D6</td><td>D7</td><td>D8</td><td>Stop</td><td>Repeat</td> </tr> </table>	Custom Code 8bit		Custom Code 8bit		Data Code 8bit		Data Code 8bit		Leader	C1	C2	C3	C4	C5	C6	C7	C8	C1	C2	C3	C4	C5	C6	C7	C8	D1	D2	D3	D4	D5	D6	D7	D8	D1	D2	D3	D4	D5	D6	D7	D8	Stop	Repeat			
Custom Code 8bit		Custom Code 8bit		Data Code 8bit		Data Code 8bit																																									
Leader	C1	C2	C3	C4	C5	C6	C7	C8	C1	C2	C3	C4	C5	C6	C7	C8	D1	D2	D3	D4	D5	D6	D7	D8	D1	D2	D3	D4	D5	D6	D7	D8	Stop	Repeat													

10

Note 1) Each wave form is available as the masked ROM option.



### (3-2) The Number of Output Frame

The number of transmission signal frame generated by minimum key input time is available as the masked ROM option. It has from 1 frame to 8 frame.

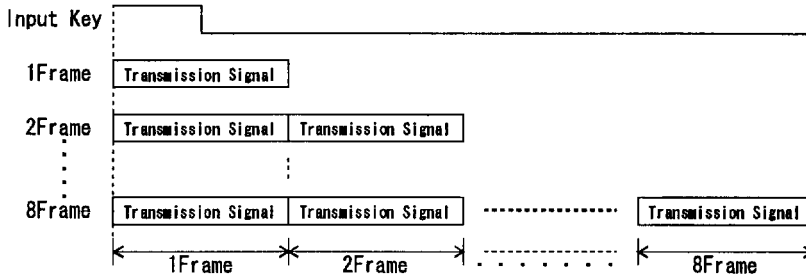

### (4) Key Operation

#### (4-1) Standard Key Operation

The key board matrix correspond to the ROM code address is shown as follows:

		Standard Key Matrix							
Key Scan		EC <sub>0</sub>	EC <sub>1</sub>	EC <sub>2</sub>	EC <sub>3</sub>	EC <sub>4</sub>	EC <sub>5</sub>	EC <sub>6</sub>	EC <sub>7</sub>
KS <sub>0</sub>	00 (KY1)	08 (KY9)	16 (KY17)	24 (KY25)	32 (KY33)	40 (KY41)	48 (KY49)	56 (KY57)	
KS <sub>1</sub>	01 (KY2)	09 (KY10)	17 (KY18)	25 (KY26)	33 (KY34)	41 (KY42)	49 (KY50)	57 (KY58)	
KS <sub>2</sub>	02 (KY3)	10 (KY11)	18 (KY19)	26 (KY27)	34 (KY35)	42 (KY43)	50 (KY51)	58 (KY59)	
KS <sub>3</sub>	03 (KY4)	11 (KY12)	19 (KY20)	27 (KY28)	35 (KY36)	43 (KY44)	51 (KY52)	59 (KY60)	
KS <sub>4</sub>	04 (KY5)	12 (KY13)	20 (KY21)	28 (KY29)	36 (KY37)	44 (KY45)	52 (KY53)	60 (KY61)	
KS <sub>5</sub>	05 (KY6)	13 (KY14)	21 (KY22)	29 (KY30)	37 (KY38)	45 (KY46)	53 (KY54)	61 (KY62)	
KS <sub>6</sub>	06 (KY7)	14 (KY15)	22 (KY23)	30 (KY31)	38 (KY39)	46 (KY47)	54 (KY55)	62 (KY63)	
KS <sub>7</sub>	07 (KY8)	15 (KY16)	23 (KY24)	31 (KY32)	39 (KY40)	47 (KY48)	55 (KY56)	63 (KY64)	

Note 2) The inside of parentheses means the key number.

Only for standard key operation, when the roll over input occurs, the transmission data in the data register is cleared by the roll over preventive circuit and the transmission is forbid.

#### (4-2) Extension Key Operation

The extension key is connected between the OPT terminal and the key scan output terminal KS<sub>5</sub> or KS<sub>7</sub>, key board matrix correspond to ROM code address is shown as follows:

Key Scan	Normal KeyMatrix	Extension Key Matrix								OPT
		EC <sub>0</sub>	EC <sub>1</sub>	EC <sub>2</sub>	EC <sub>3</sub>	EC <sub>0</sub>	EC <sub>1</sub>	EC <sub>2</sub>	EC <sub>3</sub>	
KS <sub>0</sub>	Shown upper	Not Double Press Key								
KS <sub>1</sub>										
KS <sub>2</sub>										
KS <sub>3</sub>										
KS <sub>4</sub>										
KS <sub>5</sub>		40	41	42	43	44	45	46	47	KY65
KS <sub>6</sub>		48	49	4A	4B	4C	4D	4E	4F	KY66
KS <sub>7</sub>										

The extension key is formed by the KY33 and the KY34, and it is generated the extension code by operating with the combination key.



The combination key corresponded to the extension key is as follows:

Double Space Key	Combination Key							
KY65	KY7	KY15	KY23	KY31	KY39	KY47	KY55	KY63
KY66	KY8	KY16	KY24	KY32	KY40	KY48	KY56	KY64

It is correspondence as this table, therefore any other combinations aren't transmitted, besides, only extension key KY65 or KY66 isn't transmitted. The extension key should be pushed with the combination key.

#### (4-3) Key Timing Prevented Of Two Key Roll Over

The timing of key scan is 0.21msec. The time to stop scanning is about 36msec. Besides, to prevent chattering of key ON, a data isn't read for 9msec after pressing a key. Therefore the key timing prevented of two key roll over is as follow:

- ① Pressing At The Same Time Within 36msec → Forbidding Transmission

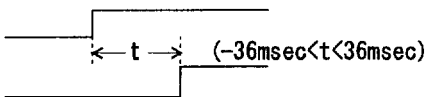

↑ Key ON

- ② Pressing Second Key after 36msec

→ After Transmitting First Key Data, Forbidding Transmission

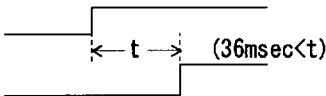

↑ Key ON

- ③ Taking Off Both Key Within 36msec

→ Forbidding Transmission

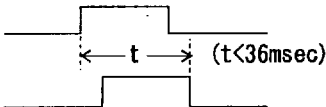

↑ Key ON      ↓ Key OFF

- ④ Taking Off The Other Key After 36msec

→ Transmitting Rest Key Data

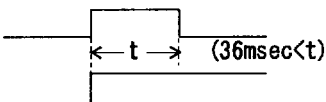

↑ Key ON

As this, provided an key is kept to press over 36msec, its code is transmitted once.

#### (4-4) Roll Over Timing Of Extension Key

When keys are pressed over two at the same time, transmission is usually forbid by the roll over preventive circuit. However, when the extension key is pressed, it is transmitted by operating with the combination key at input timing as follows:



## ① Extension Key Signal Transmission

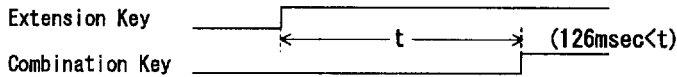

## ② Forbidding Extension Key Signal Transmission

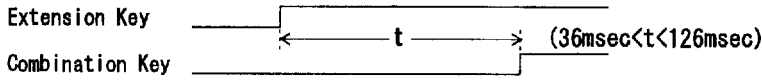

## ③ Forbidding Extension Key Signal Transmission

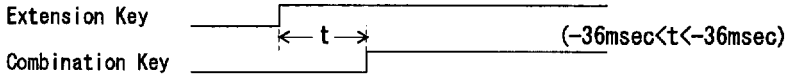

## ④ Forbidding Extension Key Signal Transmission

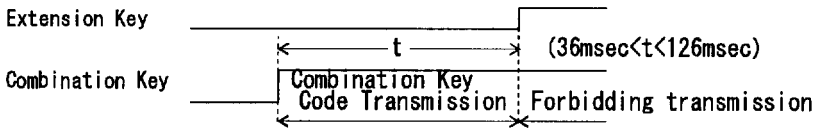

For the order of the priority of pressing key, the extension key can operate when only the combination key is pressed after 126msec at the time of pressing the extension key.

## (5) Carrier Frequency Generating Circuit

Each other ceramic resonator corresponded to the carrier wave frequency is shown below.

For ROM option, the ceramic resonator should be specified.

	Ceramics resonator fosc (kHz)				
	393	440	455	480	455
Carrier Frequency fca (kHz)	32.8	36.7	37.9	40.0	56.9
Dividing Frequency Percentage	fosc/12	fosc/12	fosc/12	fosc/12	fosc/8

The carrier frequency is output in 1/3 duty.

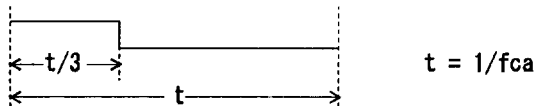

In case of using the ceramic resonator 455kHz and set the frequency dividing ratio to fosc/8, the carrier frequency is 1/2 duty.



### (6) Auto Clear Circuit

Connecting the capacitor between the  $\overline{AC}$  terminal and  $V_{SS}$ , auto clear function is executed at the time of power-on. After the  $V_{DD}$  terminal voltage is risen to  $0.9V$ , it is required that the period ( $T_c$ ) which the  $\overline{AC}$  terminal voltage ( $V_c$ ) becomes  $V_c > 0.3V_{DD}$  is  $T_c > 0.1\text{msec}$ . After auto clear function is executed, this circuit is kept the stand-by mode until a key is input.

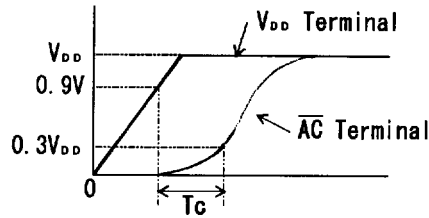
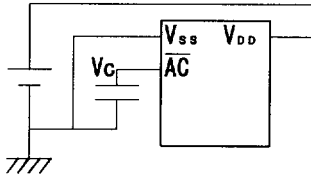

An external capacitance should be connected value more than  $2\text{nF}$ .  
Example expressions are shown below.

- For example ( $V_{DD}=1.5\text{V}$  Operating)

- $V_{min}$ : Minimum Operating Voltage ( $1.1\text{V}$ )
- $V_c$ :  $\overline{AC}$  Terminal Voltage ( $0.3V_{DD}$ )
- $T_c$ : Time Until  $\overline{AC}$  Terminal is  $V_c > 0.3V$  (more than  $0.1\text{ms}$ )
- $R$ : Internal Pull-Up Resistance ( $80\text{k}\Omega$ )
- $C$ : External Capacitance

$$V_c = V_{min} (1 - e^{-\frac{T_c}{CR}})$$

$$T_c = -CR \times \log\left(1 - \frac{V_c}{V_{min}}\right)$$

$$0.1 (\text{ms}) \leq -C \times 80 (\text{k}\Omega) \times \log\left(1 - \frac{0.45 (\text{V})}{1.1 (\text{V})}\right)$$

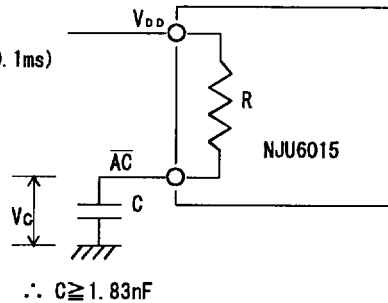

Therefore, in order to be executed auto clear function exactly, the capacitance more than this numerical value should be connected.

**■ ABSOLUTE MAXIMUM RATINGS**

(Ta=25°C)

PARAMETER	SYMBOL	RATINGS	UNIT
Supply Voltage	V <sub>DD</sub>	-0.3 ~ +3.0	V
Input Voltage	V <sub>IN</sub>	V <sub>SS</sub> -0.3 ~ V <sub>DD</sub> +0.3	V
Operating Temperature	T <sub>opr</sub>	- 25 ~ + 75	°C
Storage Temperature	T <sub>stg</sub>	- 40 ~ + 125	°C

**■ ELECTRICAL CHARACTERISTICS**

 (V<sub>DD</sub>=1.2V, Ta=25°C)

PARAMETER	SYMBOL	CONDITIONS	MIN.	TYP.	MAX.	UNIT	NOTE
Operating Voltage	V <sub>DD</sub>	fosc=455kHz	1.1		1.8	V	
Operating Current	I <sub>DD</sub>	fosc=455kHz			0.6	mA	
Stand-by Current	I <sub>ST</sub>				1.0	μA	
"H" Input Voltage	V <sub>IH</sub>	Each EC, OPT Terminal	0.7V <sub>DD</sub>		V <sub>DD</sub>	V	
"L" Input Voltage	V <sub>IL</sub>	Each EC, OPT Terminal			0.3V <sub>DD</sub>	V	
Oscillation Frequency	fosc	X <sub>IN</sub> , X <sub>OUT</sub> Terminal		393 440 455 480		kHz	3
Output Current(1)	I <sub>OL1</sub>	V <sub>OL</sub> =0.3V	0.1	0.3		mA	
	I <sub>OH1</sub>	V <sub>OH</sub> =0.9V					
Output Current(2)	I <sub>OL2</sub>	V <sub>OL</sub> =0.9V	0.5	1.0		mA	
Feedback Resistance	R <sub>f</sub>	X <sub>IN</sub> =V <sub>DD</sub>		1		MΩ	
Pull-up Resistance	R <sub>11</sub>	OPT Terminal		100		kΩ	
	R <sub>12</sub>	Each EC Terminal		100			
	R <sub>13</sub>	AC Terminal		80			
Pull-down Resistance	R <sub>14</sub>	TEST Terminal		200		kΩ	

Note 3) The oscillation frequency is turned by depending the ceramic resonator.

The carrier frequency is the masked ROM option ,therefore the ceramic resonator should be designated.



■ APPLICATION CIRCUIT

(1) Normal Key

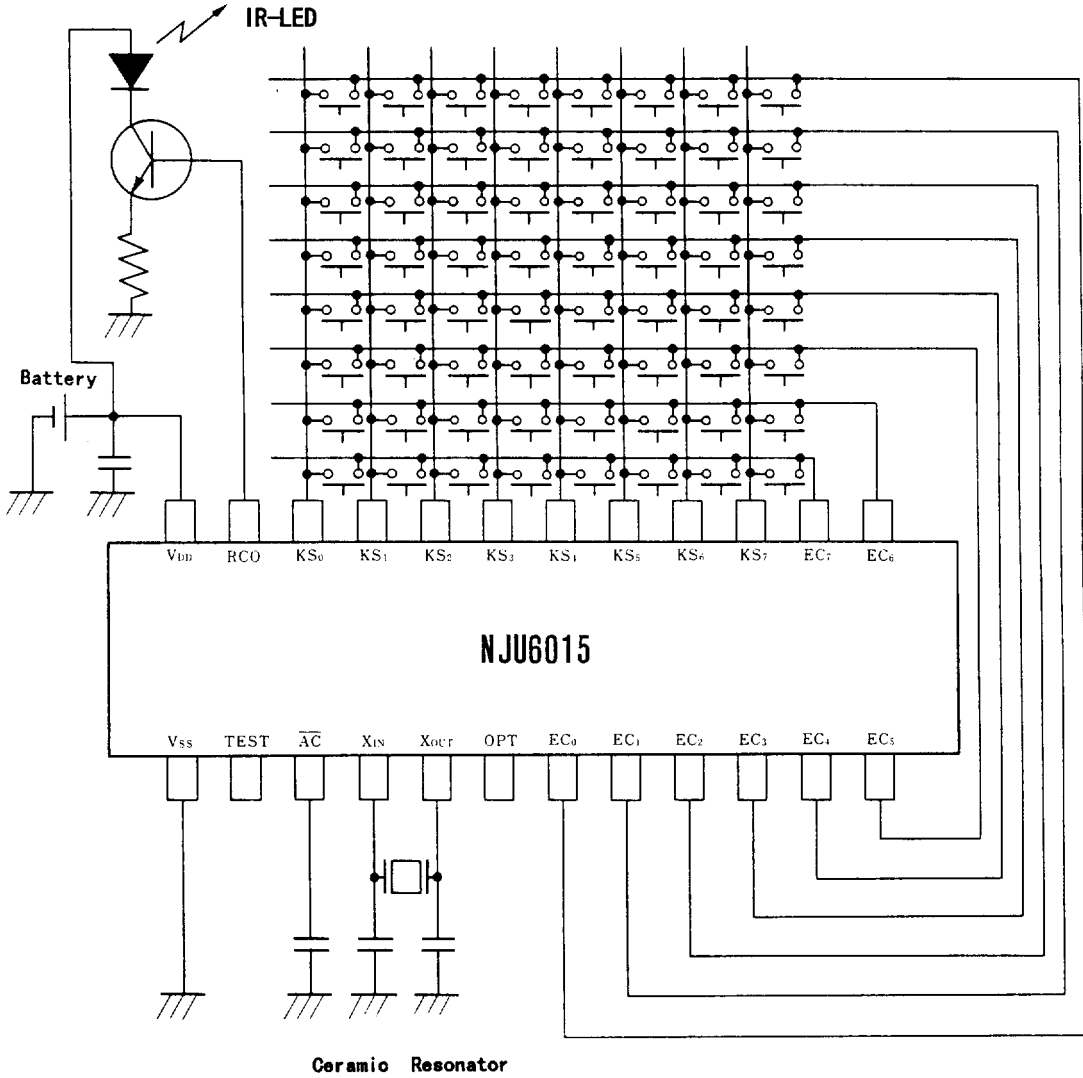

10



## (2) Double Press Key

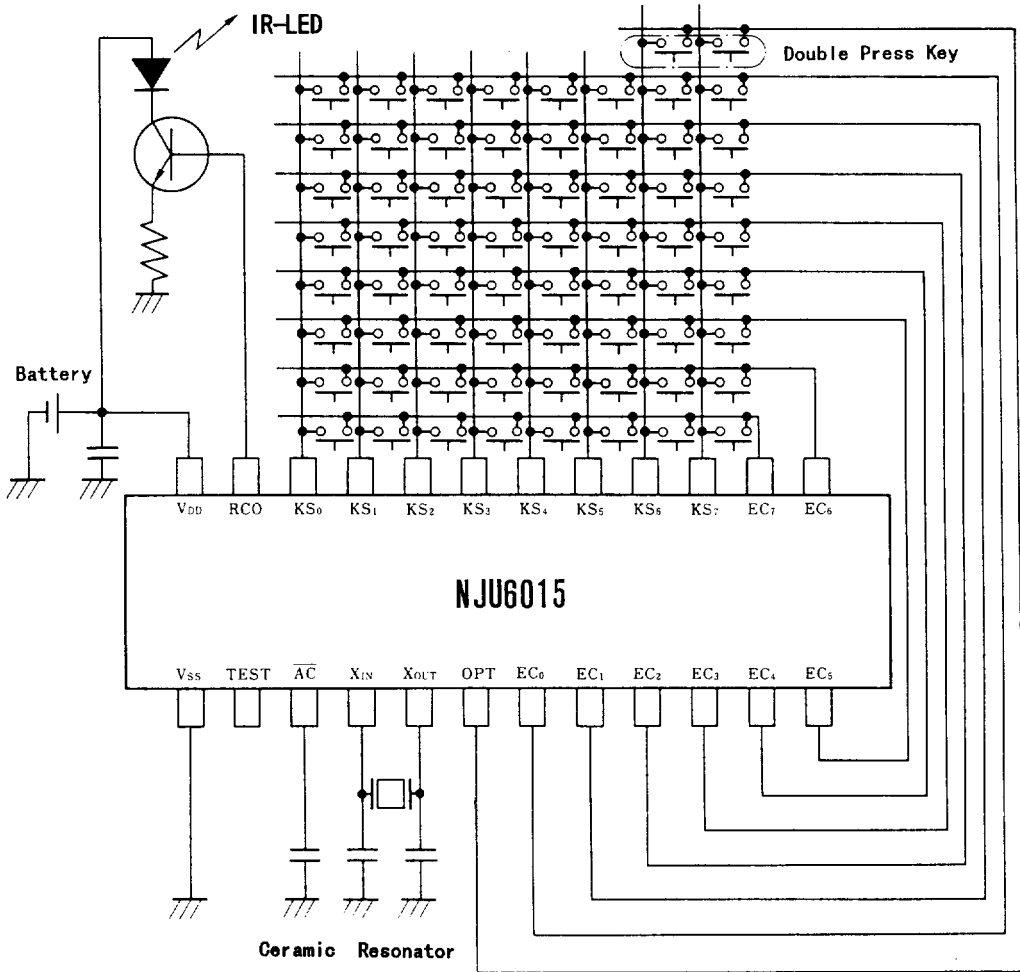

10