

Data Sheet

DESCRIPTION

The SSI 204 is a complete Dual Tone Multiple Frequency (DTMF) receiver that detects all 16 standard digits. No front-end pre-filtering is needed. The only externally required components are an inexpensive 3.58-MHz television "color-burst" crystal for frequency reference and a bias resistor. An Alternate Time Base (ATB) is provided to permit operation of up to 10 SSI 204's from a single crystal. The SSI 204 employs state-of-the-art "switched-capacitor" filter technology, resulting in approximately 40 poles of filtering, and digital circuitry on the same CMOS chip. The analog input signal is pre-processed by 60-Hz reject and band split filters and then zero-cross detected to provide AGC. Eight bandpass filters detect the individual tones. Digital processing is used to measure the tone and pause durations and to provide output timing and decoding. The outputs interface directly to standard CMOS circuitry and are three-state enabled to facilitate bus-oriented architectures.

FEATURES

- Intended for applications with less requirements than the SSI 202
- 14-Pin plastic DIP for high system density
- NO front-end band splitting filters required
- Single low-tolerance 5-volt supply
- Detects all 16 standard DTMF digits
- Uses inexpensive 3.579545-MHz crystal
- Excellent speech immunity
- Output in 4-bit hexadecimal code
- Three-state outputs for microprocessor interface

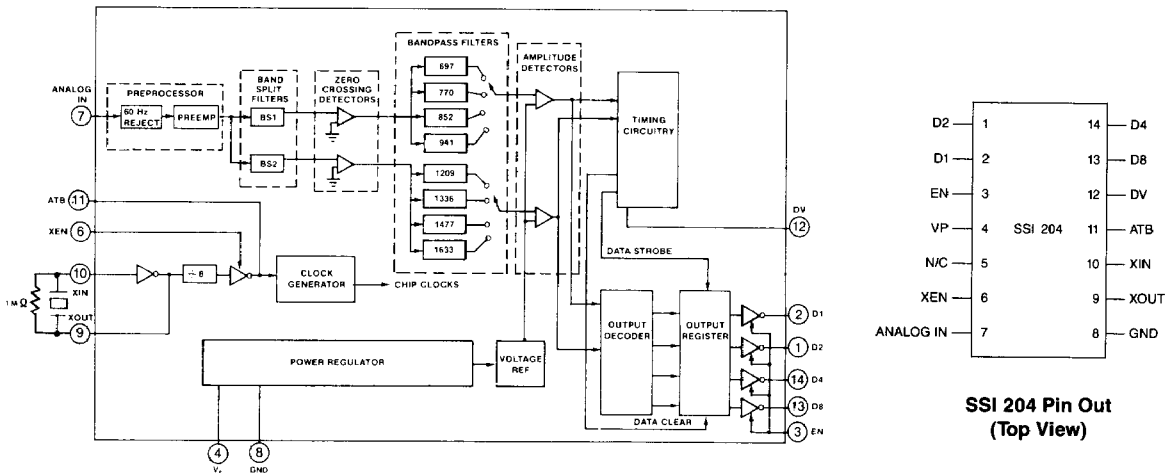

Block Diagram

CAUTION: Use handling procedures necessary for a static sensitive component

SSI 204

5V Low Power

Subscriber

DTMF Receiver

ANALOG IN

This pin accepts the analog input. It is internally biased so that the input signal may be AC coupled. The input may be DC coupled as long as it does not exceed the positive supply. Proper input coupling is illustrated below.

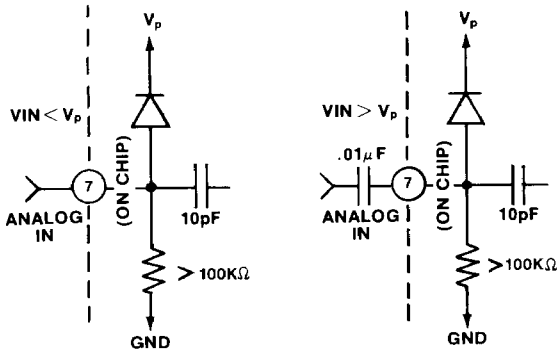

The SSI 204 is designed to accept sinusoidal input wave forms but will operate satisfactorily with any input that has the correct fundamental frequency with harmonics greater than 20 dB below the fundamental.

CRYSTAL OSCILLATOR

The SSI 204 contains an onboard inverter with sufficient gain to provide oscillation when connected to a low-cost television "color-burst" crystal. The crystal oscillator is enabled by tying XEN high. The crystal is connected between XIN and XOUT. A 1 MΩ 10% resistor is also connected between these pins. In this mode, ATB is a clock frequency output. Other SSI 204's (or 202's) may use the same frequency reference by tying their ATB pins to the ATB of a crystal connected device. XIN and XEN of the auxiliary devices must then be tied high and low respectively. Ten devices may run off a single crystal-connected SSI 204 (or 202) as shown below.

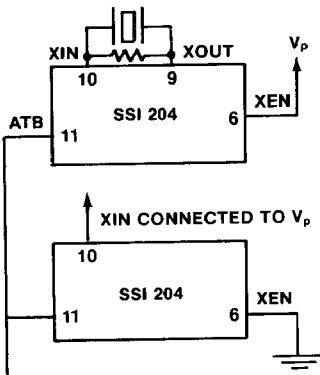

UP TO 10 DEVICES

OUTPUTS D1, D2, D4, D8, and EN

Outputs D1, D2, D4, D8 are CMOS push-pull when enabled (EN high) and open circuited (high impedance) when disabled by pulling EN low. These digital outputs provide the hexadecimal code corresponding to the detected digit. The digital outputs become valid after a tone pair has been detected and they are then cleared when a valid pause is timed. The table below describes the hexadecimal codes.

OUTPUT CODE				
Digit	D8	D4	D2	D1
1	0	0	0	1
2	0	0	1	0
3	0	0	1	1
4	0	1	0	0
5	0	1	0	1
6	0	1	1	0
7	0	1	1	1
8	1	0	0	0
9	1	0	0	1
0	1	0	1	0
*	1	0	1	1
#	1	1	0	0
A	1	1	0	1
B	1	1	1	0
C	1	1	1	1
D	0	0	0	0

DV

DV signals a detection by going high after a valid tone pair is sensed and decoded at the output pins D1, D2, D4, D8. DV remains high until a valid pause occurs.

N/C PIN

This pin has no internal connection and may be left floating.

DTMF DIALING MATRIX

	Col 0	Col 1	Col 2	Col 3
Row 0	1	2	3	A
Row 1	4	5	6	B
Row 2	7	8	9	C
Row 3	*	0	#	D

Note: Column 3 is for special applications and is not normally used in telephone dialing.

DETECTION FREQUENCY

Low Group f_0	High Group f_0
Row 0 = 697 Hz	Column 0 = 1209 Hz
Row 1 = 770 Hz	Column 1 = 1336 Hz
Row 2 = 852 Hz	Column 2 = 1477 Hz
Row 3 = 941 Hz	Column 3 = 1633 Hz

APPLICATION NOTES

The SSI 204 will tolerate total input rms noise up to 12dB below the lowest amplitude tone. For most telephone applications, the combination of the high frequency attenuation of the telephone line and internal band-limiting make special circuitry at the input to the SSI 204 unnecessary. However, noise near the 56kHz internal sampling frequency will be aliased (folded back) into the audio spectrum, so if excessive noise is present above 28kHz, the simple RC filter as shown below may be employed to band limit the incoming signal.

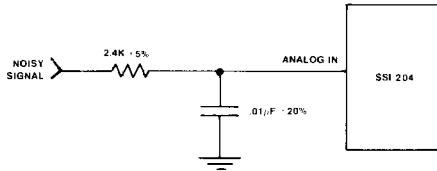

Filter for use in extreme high frequency input noise environment.

Noise will also be reduced by placing a grounded trace around XIN and XOUT pins on the circuit board layout when using a crystal. It is important to note that XOUT is not intended to drive an additional device. XIN may be driven externally; in this case leave XOUT floating.

SSI 204 TIMING

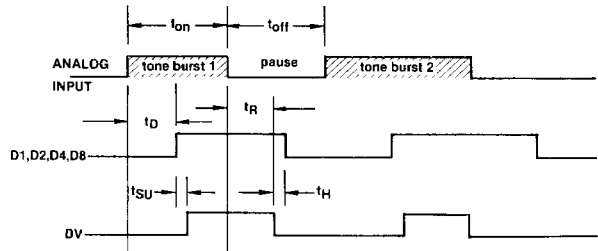

PARAMETER	SYMBOL	MIN.	TYP.	MAX.	UNITS
TONE TIME: for detection	t_{ON}	40	—	—	mS
	for rejection	t_{ON}	—	—	20
PAUSE TIME: for detection	t_{OFF}	40	—	—	mS
	for rejection	t_{OFF}	—	—	20
DETECT TIME	t_D	25	—	46	mS
RELEASE TIME	t_R	35	—	50	mS
DATA SETUP TIME	t_{SU}	7	—	—	μ S
DATA HOLD TIME	t_H	4.2	—	5.0	mS
OUTPUT ENABLE TIME	—	—	200	300	nS
$C_L = 50\text{pF}$ $R_L = 1\text{K}\Omega$					
OUTPUT DISABLE TIME	—	—	150	200	nS
$C_L = 35\text{pF}$ $R_L = 500\Omega$					
OUTPUT RISE TIME	—	—	200	300	nS
$C_L = 50\text{pF}$					
OUTPUT FALL TIME	—	—	160	250	nS
$C_L = 50\text{pF}$					

ABSOLUTE MAXIMUM RATINGS*

DC Supply Voltage V_p +7 Volts
 Operating Temperature -40°C to +85°C Ambient
 Storage Temperature -65°C to 150°C
 Power Dissipation (25°C) 65 mW
 (Derate above $T_A = 25^\circ\text{C}$ @ 6.25 mW/°C)
 Input Voltage ($V_p + 0.5\text{V}$) to - 0.5V
 (all inputs except ANALOG IN)

ANALOG IN Voltage ($V_p + 0.5\text{V}$) to ($V_p - 10\text{V}$)
 DC Current into any Input $\pm 1.0\text{mA}$
 Lead Temperature 300°C
 (soldering, 10 sec.)

*Operation above absolute maximum ratings may damage the device.

Note: All SSI 204 unused inputs must be connected to V_p or Gnd. as appropriate.

ELECTRICAL CHARACTERISTICS ($-40^{\circ}\text{C} \leq T_A \leq +85^{\circ}\text{C}$, $V_s = 5\text{V} \pm 10\%$)

Parameter	Conditions	Min	Typ	Max	Units
Frequency Detect Bandwidth		$\pm(1.5 + 2 \text{ Hz})$	± 23	± 3.5	% of f_c
Amplitude for Detection	each tone	-32		-2	dBm referenced to 600 Ω
Minimum Acceptable Twist	twist = $\frac{\text{high tone}}{\text{low tone}}$	-8		+4	dB
60-Hz Tolerance				0.8	Vrms
Dial Tone Tolerance	"precise" dial tone			0dB	dB referenced to lower amplitude tone
Talk-Off	MITEL tape #CM 7290		2		hits
Digital Outputs (except XOUT)	"0" level, 400 μA load "1" level, 200 μA load	0 $V_i - 0.5$		0.5 V_i	V V
Digital Inputs	"0" level "1" level	0 0.7V		0.3V _i V_i	V V
Power Supply Noise	wide band			10	mV p-p
Supply Current	$T_A = 25^{\circ}\text{C}$		10	16	mA
Noise Tolerance	MITEL tape #CM 7290			-12	dB referenced to lowest amplitude tone
Input Impedance	$V_i \geq V_s \geq V_i - 10\text{V}$	100K Ω /15pF			

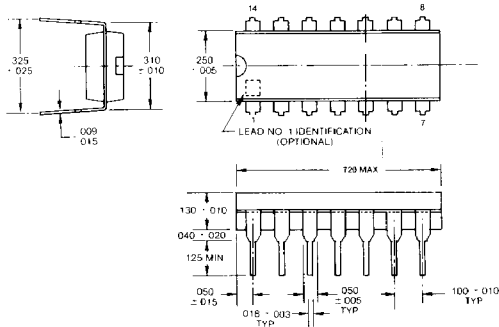

No responsibility is assumed by SSI for use of this product nor for any infringements of patents and trademarks or other rights of third parties resulting from its use. No license is granted under any patents, patent

rights or trademarks of SSI. SSI reserves the right to make changes in specifications at any time and without notice.