

MN3310 MN3311

16 BIT D/A CONVERTERS

FEATURES

- Complete Internal Reference Internal Output Amplifier
- Small 24 Pin DIP
- $\pm 0.003\%$ Linearity 0°C to $+70^\circ\text{C}$
- Fast Settling
35 μSec (Max) MN3310
70 μSec (Max) MN3311
- Low Power
420 mW Maximum

24 PIN DIP

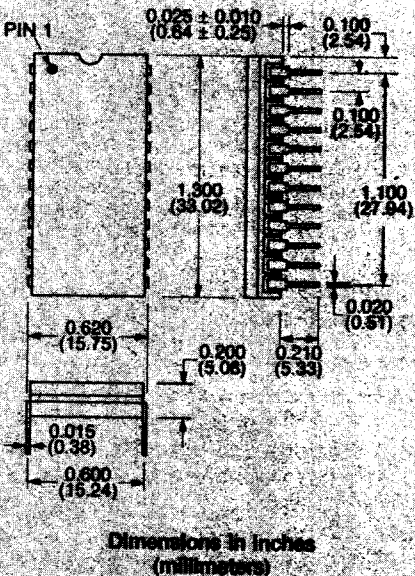

DESCRIPTION

The MN3310 and MN3311 are 16 Bit, binary, voltage output Digital to Analog Converters housed in small, 24 pin Dual-in-Line packages. Both are complete with internal reference and output amplifier and are fully specified over the 0°C to $+70^\circ\text{C}$ operating temperature range. $\pm 0.003\%$ linearity and 14 bit monotonicity are guaranteed over temperature, and overall absolute accuracy is guaranteed to be better than $\pm 0.08\%$ FSR at $+25^\circ\text{C}$ and better than $\pm 0.3\%$ FSR over temperature.

The MN3310 and MN3311 employ functional laser trimming to eliminate the need for external trimpots, and all specifications are met without adjustment. An optional offset adjust point is brought out, however, for applications requiring greater accuracies.

APPLICATIONS

The MN3310 and MN3311 are ideal choices for applications requiring high resolution, small size, and low power consumption. Typical applications include high resolution servo and control systems, high accuracy function generation, and precision instrumentation.

BLOCK DIAGRAM

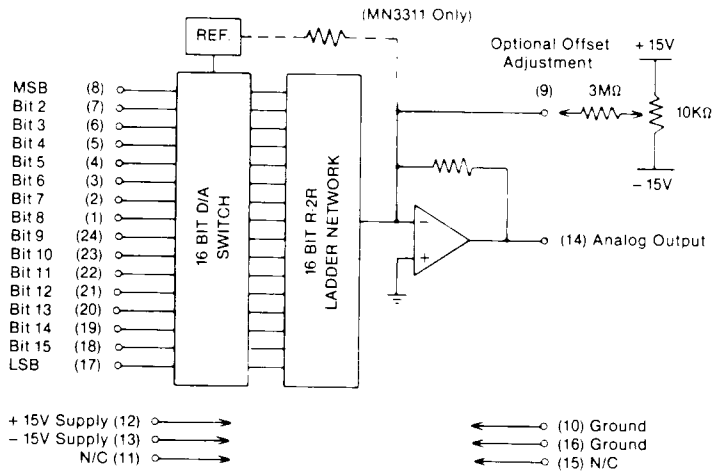

Micro Networks Corporation
324 Clark Street, Worcester, Massachusetts 01606 • (617) 852-5400
A SUBSIDIARY OF UNITRODE CORPORATION

MN3310 AND MN3311 16 BIT D/A CONVERTERS

ABSOLUTE MAXIMUM RATINGS

Operating Temperature	0°C to +70°C
Storage Temperature	-65°C to +150°C
+15V Supply (Pin 12)	+18 Volts
-15V Supply (Pin 13)	-18 Volts
Digital Inputs (Pins 1-8, 17-24)	-0.5 to +15 Volts

SPECIFICATIONS ($T_A = 25^\circ\text{C}$, Supply Voltages $\pm 15\text{V}$, unless otherwise specified).

DIGITAL INPUTS	MIN.	TYP.	MAX.	UNITS
Logic Levels: Logic "1" Logic "0"	2.0		0.8	Volts Volts
Input Currents: Logic "1" Logic "0"			1 -0.5	μA mA
ANALOG OUTPUTS				
Output Voltage Range: MN3310 MN3311		0 to -10 -10 to +10		Volts Volts
Output Impedance Output Load Current Maximum Capacitive Load	± 4	0.25 50		Ohms mA pf
Linearity Error (Note 1): 0°C to +70°C			± 0.003	% FSR
Monotonicity: 0°C to +70°C	14			Bits
Absolute Accuracy Error (Notes 2,3): +25°C 0°C to +70°C		± 0.04 ± 0.15	± 0.08 ± 0.3	% FSR % FSR
Output Slew Rate Settling Time (Full Scale Change to $\pm 0.003\%$ FSR): MN3310 MN3311		0.5 20 40	35 70	Volts/ μSec μSec μSec
Power Supply Range: +15V Supply -15V Supply	+14.55 -14.55	+15.00 -15.00	+15.45 -15.45	Volts Volts
Power Supply Rejection (Note 4): +15V Supply -15V Supply		± 0.005 ± 0.03		% FSR /% Vs % FSR /% Vs
Current Drain, Output Unloaded: +15V Supply -15V Supply		9 -10	13 -15	mA mA
Power Consumption		285	420	mW

SPECIFICATION NOTES

- Micro Networks tests and guarantees maximum linearity error at room temperature and at both extremes of the specified operating temperature range.
- The Absolute Accuracy Error of a voltage output D/A is the difference between the actual output voltage that appears following the application of a given digital input code and the ideal or expected output voltage for that code. Absolute Accuracy Error includes gain, offset, linearity, and noise errors and encompasses the drifts of these errors when specified over temperature. For the MN3310 and MN3311, we test Absolute Accuracy Error with all "1" and all "0" digital inputs. We also test the MN3311 with a 0111 1111 1111 1111 digital input (ideal zero volts output). We perform these tests at +25°C and at both extremes of the

- specified operating temperature range. This testing, coupled with our linearity testing, allows us to guarantee that at +25°C, any analog output will be within $\pm 0.08\%$ FSR of its ideal value and that from 0°C to +70°C, any analog output will be within $\pm 0.3\%$ FSR of its ideal value. A constant voltage can be added to or subtracted from the analog output using the offset potentiometer shown in the block diagram.
- For a 16 bit converter, 1 LSB corresponds to 0.0015% FSR. FSR stands for Full Scale Range and is equivalent to the peak to peak voltage of the output range. For the MN3310, FSR = 10V, and 1 LSB = 152.6 μV . For the MN3311, FSR = 20V, and 1 LSB = 305.2 μV .
 - The MN3310 and MN3311 will operate over a power supply range of $\pm 13\text{V}$ to $\pm 17\text{V}$ with reduced accuracy.

DIGITAL INPUT CODING

DIGITAL INPUT				ANALOG OUTPUT (DC VOLTS)	
MSB	LSB			MN3310	MN3311
0000	0000	0000	0000	0.00000	+9.99969
0000	0000	0000	0001	-0.00015	+9.99939
0111	1111	1111	1111	-4.99985	0.00000
1000	0000	0000	0000	-5.00000	-0.00031
1111	1111	1111	1110	-9.99969	-9.99969
1111	1111	1111	1111	-9.99985	-10.00000

LAYOUT CONSIDERATIONS

Proper attention to layout and decoupling is necessary to obtain specified accuracies. The units' two ground pins (Pins 10 and 16) should be tied together as close to the unit

as possible and both connected to circuit analog ground, preferably through a large ground plane underneath the package. If these commons must be run separately, a non-polarized 0.01 μF bypass capacitor should be connected between pins 10 and 16 as close to the unit as possible and wide conductor runs employed. Power supplies should be decoupled with 1 μF capacitors paralleled with 0.01 μF ceramic capacitors as shown in the diagram.

