

MM54HC147/MM74HC147



T-67-21-57

MM54HC147/MM74HC147 10-to-4 Line Priority Encoder

General Description

This high speed 10-to-4 Line Priority Encoder utilizes advanced silicon-gate CMOS technology. It possesses the high noise immunity and low power consumption of standard CMOS integrated circuits. This device is fully buffered, giving it a fanout of 10 LS-TTL loads.

The MM54HC147/MM74HC147 features priority encoding of the inputs to ensure that only the highest order data line is encoded. Nine input lines are encoded to a four line BCD output. The implied decimal zero condition requires no input condition as zero is encoded when all nine data lines are at a high logic level. All data inputs and outputs are active at the low logic level.

The 54HC/74HC logic family is functionally as well as pin-out compatible with the standard 54LS/74LS logic family. All inputs are protected from damage due to static discharge by internal diode clamps to V_{CC} and ground.

Features

- Low quiescent power consumption: 40 μW maximum at 25°C
- High speed: 31 ns propagation delay (typical)
- Low input current: 1 μA maximum
- Wide supply range: 2V to 6V

Connection and Logic Diagrams

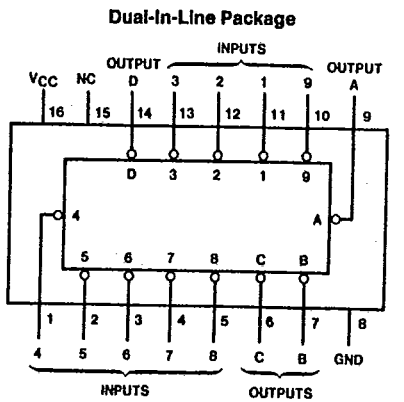

TL/F/5007-1

Top View

Order Number MM54HC147* or MM74HC147*

*Please look into Section 8, Appendix D for availability of various package types.

Truth Table

Inputs									Outputs			
1	2	3	4	5	6	7	8	9	D	C	B	A
H	H	H	H	H	H	H	H	H	H	H	H	H
X	X	X	X	X	X	X	X	L	L	H	H	L
X	X	X	X	X	X	X	L	H	L	H	H	H
X	X	X	X	X	L	H	H	H	H	L	L	L
X	X	X	X	L	H	H	H	H	H	L	H	L
X	X	X	L	H	H	H	H	H	H	L	H	H
X	X	L	H	H	H	H	H	H	H	H	L	L
X	L	H	H	H	H	H	H	H	H	H	L	H
L	H	H	H	H	H	H	H	H	H	H	H	L

H = High Logic Level, L = Low Logic Level, X = Irrelevant

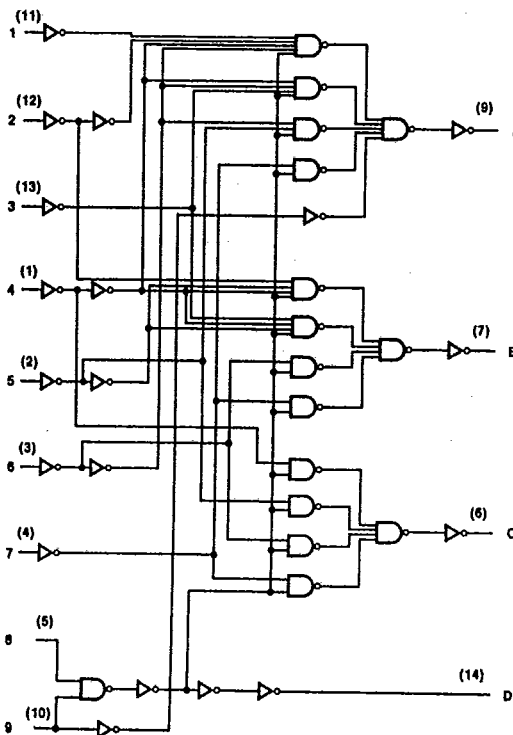

TL/F/5007-2

T-67-21-57

MM54HC147/MN74HC147

Absolute Maximum Ratings (Notes 1 & 2)

If Military/Aerospace specified devices are required, contact the National Semiconductor Sales Office/Distributors for availability and specifications.

Supply Voltage (V _{CC})	-0.5 to +7.0V
DC Input Voltage (V _{IN})	-1.5 to V _{CC} +1.5V
DC Output Voltage (V _{OUT})	-0.5 to V _{CC} +0.5V
Clamp Diode Current (I _{IK} , I _{OK})	±20 mA
DC Output Current, per pin (I _{OUT})	±25 mA
DC V _{CC} or GND Current, per pin (I _{CC})	±50 mA
Storage Temperature Range (T _{STG})	-65°C to +150°C
Power Dissipation (P _D)	
(Note 3)	600 mW
S.O. Package only	500 mW
Lead Temp. (T _L) (Soldering 10 seconds)	260°C

Operating Conditions

	Min	Max	Units
Supply Voltage (V _{CC})	2	6	V
DC Input or Output Voltage (V _{IN} , V _{OUT})	0	V _{CC}	V
Operating Temp. Range (T _A)			
MM74HC	-40	+85	°C
MM54HC	-55	+125	°C
Input Rise or Fall Times (t _r , t _f)			
V _{CC} =2.0V		1000	ns
V _{CC} =4.5V		500	ns
V _{CC} =6.0V		400	ns

DC Electrical Characteristics (Note 4)

Symbol	Parameter	Conditions	V _{CC}	T _A = 25°C			Units	
				Typ	74HC T _A = -40 to 85°C	54HC T _A = -55 to 125°C		
V _{IH}	Minimum High Level Input Voltage		2.0V	1.5	1.5	1.5	V	
			4.5V	3.15	3.15	3.15	V	
			6.0V	4.2	4.2	4.2	V	
V _{IL}	Maximum Low Level Input Voltage**		2.0V	0.5	0.5	0.5	V	
			4.5V	1.35	1.35	1.35	V	
			6.0V	1.8	1.8	1.8	V	
V _{OH}	Minimum High Level Output Voltage	V _{IN} = V _{IH} or V _{IL} I _{OUT} ≤ 20 μA	2.0V	2.0	1.9	1.9	V	
			4.5V	4.5	4.4	4.4	V	
			6.0V	6.0	5.9	5.9	V	
		V _{IN} = V _{IH} or V _{IL} I _{OUT} ≤ 4.0 mA I _{OUT} ≤ 5.2 mA	4.5V	4.7	3.98	3.84	3.7	V
			6.0V	5.2	5.48	5.34	5.2	V
V _{OL}	Maximum Low Level Output Voltage	V _{IN} = V _{IH} or V _{IL} I _{OUT} ≤ 20 μA	2.0V	0	0.1	0.1	V	
			4.5V	0	0.1	0.1	V	
			6.0V	0	0.1	0.1	V	
		V _{IN} = V _{IH} or V _{IL} I _{OUT} ≤ 4.0 mA I _{OUT} ≤ 5.2 mA	4.5V	0.2	0.26	0.33	0.4	V
			6.0V	0.2	0.26	0.33	0.4	V
I _{IN}	Maximum Input Current	V _{IN} = V _{CC} or GND	6.0V		±0.1	±1.0	±1.0	μA
I _{CC}	Maximum Quiescent Supply Current	V _{IN} = V _{CC} or GND I _{OUT} = 0 μA	6.0V		8.0	80	160	μA

Note 1: Absolute Maximum Ratings are those values beyond which damage to the device may occur.

Note 2: Unless otherwise specified all voltages are referenced to ground.

Note 3: Power Dissipation temperature derating — plastic "N" package: -12 mW/°C from 65°C to 85°C; ceramic "J" package: -12 mW/°C from 100°C to 125°C.

Note 4: For a power supply of 5V ± 10% the worst case output voltages (V_{OH} and V_{OL}) occur for HC at 4.5V. Thus the 4.5V values should be used when designing with this supply. Worst case V_{IH} and V_{IL} occur at V_{CC} = 5.5V and 4.5V respectively. (The V_{IH} value at 5.5V is 3.85V.) The worst case leakage current (I_{IN}, I_{CC}, and I_{OZ}) occur for CMOS at the higher voltage and so the 6.0V values should be used.

**V_{IL} limits are currently tested at 20% of V_{CC}. The above V_{IL} specification (30% of V_{CC}) will be implemented no later than Q1, CY'89.

3

T-67-21-57

MM54HC147/MM74HC147

AC Electrical Characteristics $V_{CC}=5V, T_A=25^{\circ}C, C_L=15\text{ pF}, t_r=t_f=6\text{ ns}$

Symbol	Parameter	Conditions	Typ	Guaranteed Limit	Units
t_{PHL}, t_{PLH}	Maximum Propagation Delay		31	38	ns

AC Electrical Characteristics $V_{CC}=2.0V\text{ to }6.0V, C_L=50\text{ pF}, t_r=t_f=6\text{ ns}$ (unless otherwise specified)

Symbol	Parameter	Conditions	V_{CC}	$T_A=25^{\circ}C$		74HC	54HC	Units
				Typ	Guaranteed Limits		$T_A=-40\text{ to }85^{\circ}C$	
t_{PHL}, t_{PLH}	Maximum Propagation Delay		2.0V	181	220	275	319	ns
			4.5V	36	44	55	64	ns
			6.0V	31	37	47	54	ns
t_{TLH}, t_{THL}	Maximum Output Rise and Fall Time		2.0V	30	75	95	110	ns
			4.5V	8	15	19	22	ns
			6.0V	7	13	16	19	ns
C_{PD}	Power Dissipation Capacitance (Note 5)	(per package)		180				pF
C_{IN}	Maximum Input Capacitance			5	10	10	10	pF

Note 5: C_{PD} determines the no load dynamic power consumption, $P_D = C_{PD} V_{CC}^2 f + I_{CC} V_{CC}$, and the no load dynamic current consumption, $I_S = C_{PD} V_{CC} f + I_{CC}$.