

Features

- Serial EEPROM Family for Configuring Altera FLEX® Devices
- Simple Interface to SRAM FPGAs
- EE Programmable 4-Mbit Serial Memories Designed to Store Configuration Programs for Field Programmable Gate Arrays (FPGAs)
- Cascadable Read Back to Support Additional Configurations or Future Higher-density Arrays
- Low-power CMOS EEPROM Process
- Programmable Reset Polarity
- Available in the Space-efficient Surface-mount PLCC Package
- In-System Programmable via 2-wire Bus
- Emulation of Atmel's AT24CXXX Serial EEPROMs
- Available in 3.3V ± 5% LV and 5V ± 5% C Versions
- System-friendly READY Pin

Description

The AT17C040A and AT17LV040A (high-density AT17A Series) FPGA Configuration EEPROMs (Configurators) provide an easy-to-use, cost-effective configuration memory for programming Altera FLEX® devices. The AT17A Series is packaged in the popular 32-pin TQFP. The AT17A Series family uses a simple serial-access procedure to configure one or more FPGA devices. The AT17A Series organization supplies enough memory to configure one or multiple smaller FPGAs. Using a feature of the AT17A Series, the user can select the polarity of the reset function by programming internal EEPROM bytes. The AT17A parts generate their own internal clock and can be used as a system “master” for loading the FPGA devices.

The Atmel devices also support a system-friendly READY pin. The READY pin is used to simplify system power-up considerations.

The AT17A Series Configurators can be programmed with industry-standard programmers, or Atmel's ATDH2200E Programming Kit.

Pin Configurations

32 TQFP

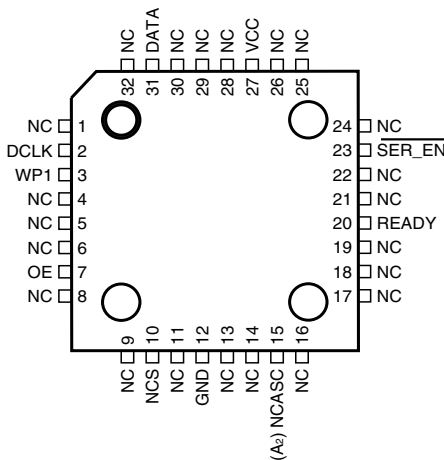

4-megabit FPGA Configuration EEPROM Memory

Altera Pinout

AT17C040A AT17LV040A Advance Information



Block Diagram

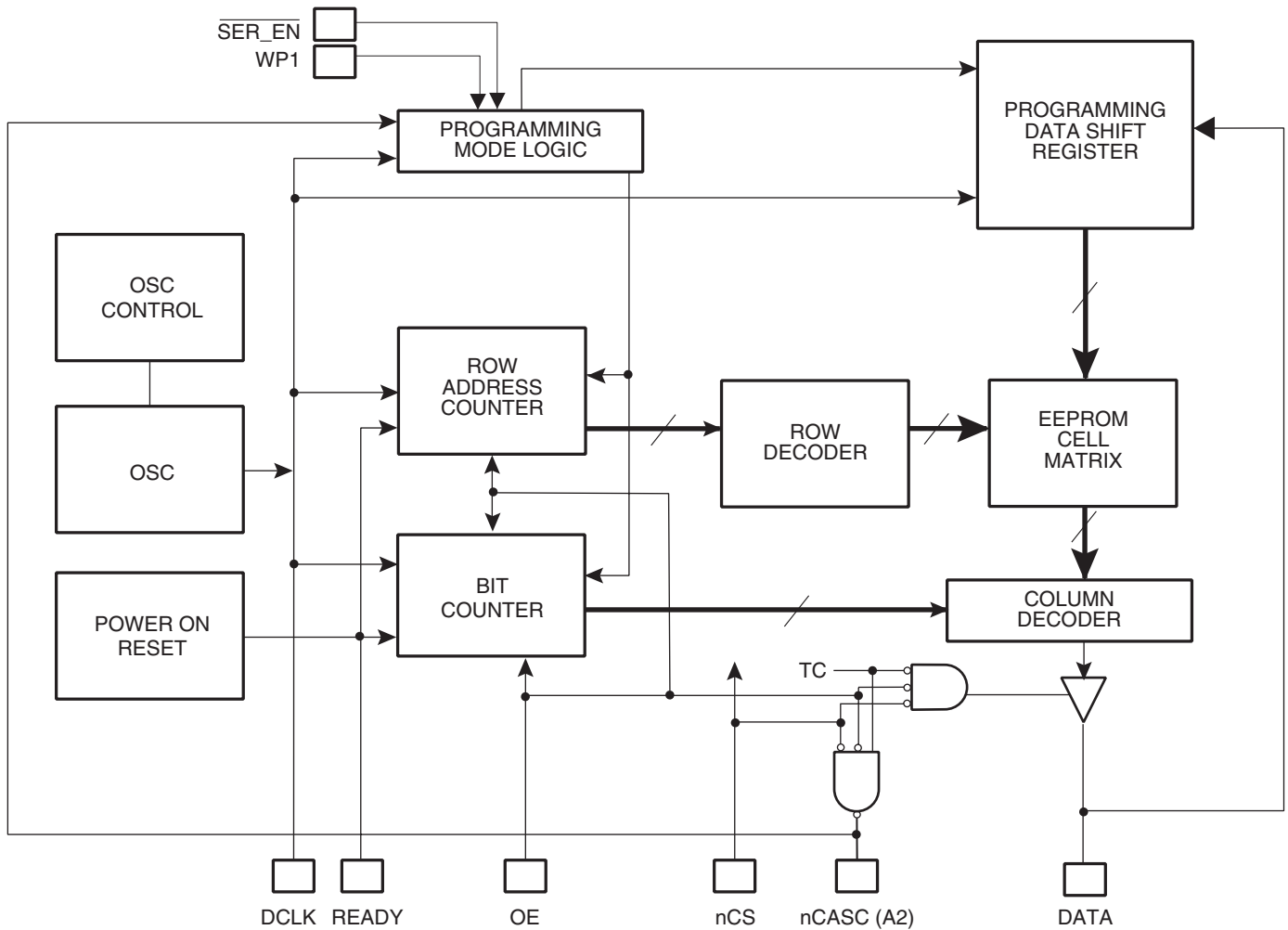

Device Configuration

The control signals for the configuration EEPROM (nCS, OE and DCLK) interface directly with the FPGA device control signals. All FPGA devices can control the entire configuration process and retrieve data from the configuration EEPROM without requiring an external intelligent controller.

The configuration EEPROM's OE and nCS pins control the tri-state buffer on the DATA output pin and enable the address counter and the oscillator. When OE is driven Low, the configuration EEPROM resets its address counter and tri-states its DATA pin. The nCS pin also controls the output of the AT17A Series Configurator. If nCS is held High after the OE reset pulse, the counter is disabled and the DATA output pin is tri-stated. When nCS is driven Low, the counter and the DATA output pin are enabled. When OE is driven Low again, the address counter is reset and the DATA output pin is tri-stated, regardless of the state of the nCS.

When the Configurator has driven out all of its data and nCASC is driven Low, the device tri-states the DATA pin to avoid contention with other Configurators. Upon power-up, the address counter is automatically reset.

The READY pin is available as an open-collector indicator of the device's reset status; it is driven Low while the device is in its power-on reset cycle and released (tri-stated) when the cycle is complete.

This document discusses the EPF10K device interface. For more details or information on other Altera applications, please reference the "AT17A Series Conversions from Altera FPGA Serial Configuration Memories" application note.

FPGA Device Configuration

FPGA devices can be configured with an AT17A Series EEPROM as shown in Figure 1. The AT17A Series device stores configuration data in its EEPROM array and clocks the data out serially with its internal oscillator. The OE, nCS, and DCLK pins supply the control signals for the address counter and the output tri-state buffer. The AT17A Series device sends a serial bitstream of configuration data to its DATA pin, which is connected to the DATA0 input pin on the FPGA device.

When the configuration data for an FPGA device exceeds the capacity of a single AT17A Series device, multiple AT17A Series devices can be serially linked together (Figure 2). When multiple AT17A Series devices are required, the nCASC and nCS pins provide handshaking between the cascaded EEPROMs.

The position of an AT17A Series device in a chain determines its operation. The first AT17A Series device in a Configurator chain is powered up or reset with nCS Low and is configured for the FPGA device's protocol. This AT17A Series device supplies all clock pulses to one or more FPGA devices and to any downstream AT17A Series Configurator during configuration. The first AT17A Series Configurator also provides the first stream of data to the FPGA devices during multi-device configuration. Once the first AT17A Series device finishes sending configuration data, it drives its nCASC pin Low, which drives the nCS pin of the second AT17A Series device Low. This activates the second AT17A Series device to send configuration data to the FPGA device.

The first AT17A Series device clocks all subsequent AT17A Series devices until configuration is complete. Once all configuration data is transferred and nCS on the first AT17A Series device is driven High by CONF_DONE on the FPGA devices, the first AT17A Series device clocks 16 additional cycles to initialize the FPGA device before going into zero-power (idle) state. If nCS on the first AT17A Series device is driven High before all configuration data is transferred – or if the nCS is not driven High after all configuration data is transferred – nSTATUS is driven Low, indicating a configuration error.

The READY pin is available as an open-collector indicator of the device's reset status; it is driven Low while the device is in its power-on reset cycle and released (tri-stated) when the cycle is complete. It can be used to hold the FPGA device in reset while it is completing its power-on reset but it cannot be used to effectively delay configuration (i.e., the output is released well before the system V_{CC} has stabilized).

Figure 1. Configuration with a Single AT17A Series Configurator

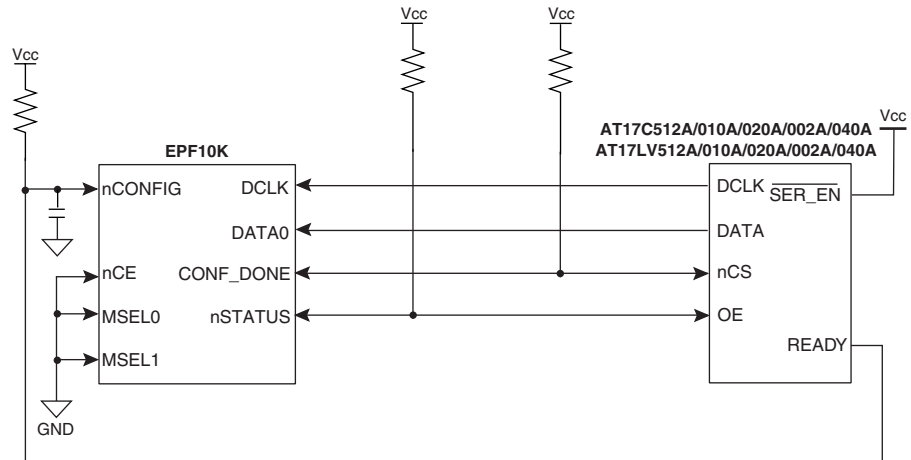

- Notes:
1. 1.0 k Ω resistors used unless otherwise specified.
 2. Applicable to EPF6K.
 3. Use of the READY pin is optional.
 4. Introducing an RC delay to the input of nCONFIG is recommended to ensure that V_{CC} (5V/3.3V) is reached before configuration begins. (nCONFIG can instead be connected to an active Low system reset signal.)
 5. Reset polarity of EEPROM must be set active Low (OE active High).
 6. 0.1 μ F capacitor used.

Figure 2. Configuration with Multiple AT17A Series Configurators

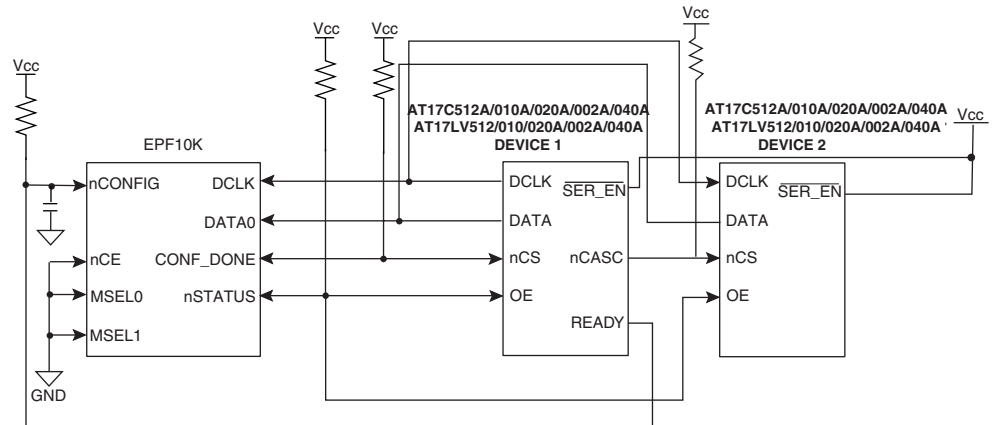

- Notes:
1. 1.0 k Ω resistors used unless otherwise specified.
 2. Use of the READY pin is optional.
 3. Introducing an RC delay to the input of nCONFIG is recommended to ensure that V_{CC} (5V/3.3V) is reached before configuration begins. (nCONFIG can instead be connected to an active Low system reset signal.)
 4. Reset polarity of EEPROM must be set active Low (OE active High).
 5. 0.1 μ F capacitor used.

AT17A Series Reset Polarity

The AT17A Series Configurator allows the user to program the polarity of the OE pin as either RESET/ \overline{OE} or \overline{RESET}/OE . For more details, please reference the “Programming Specification for Atmel’s FPGA Configuration EEPROMs” application note.

Programming Mode

The programming mode is entered by bringing $\overline{SER_EN}$ Low. In this mode the chip can be programmed by the 2-wire serial interface. The programming is done at V_{CC} supply only. Programming super voltages are generated inside the chip. See the “Programming Specification for Atmel’s Configuration EEPROMs” application note for further information. The AT17 A-series parts are read/write at 5V nominal. The AT17LV A-series parts are read/write at 3.3V nominal.

Standby Mode

The AT17A Series Configurator enters a low-power standby mode whenever nCS is asserted High. In this mode, the configuration consumes less than 0.5 mA of current at 5V. The output remains in a high-impedance state regardless of the state of the OE input.

Pin Configurations

32 TQFP Pin	Name	I/O	Description
31	DATA	I/O	Three-state data output for configuration. Open-collector bi-directional pin for programming.
2	DCLK	I/O	Clock output or clock input. Rising edges on DCLK increment the internal address counter and present the next bit of data to the DATA pin. The counter is incremented only if the OE input is held High, the nCS input is held Low, and all configuration data has not been transferred to the target device (otherwise, as the master device, the DCLK pin drives Low).
3	WP1	I	WRITE PROTECT (1). Used to protect portions of memory during programming. Disables by default due to internal pull-down resistor. This input pin is not used during FPGA loading operations. See the “Programming Specification” application note for more details.
7	OE	I	Output enable (active High) and reset (active Low) when $\overline{SER_EN}$ is High. A Low logic level resets the address counter. A High logic level (with nCS Low) enables DATA and permits the address counter to count. In the mode, if this pin is Low (reset), the internal oscillator becomes inactive and DCLK drives Low. The logic polarity of this input is programmable and must be programmed active High (RESET active Low) by the user during programming for Altera applications.
10	nCS	I	Chip select input (active Low). A Low input (with OE High) allows DCLK to increment the address counter and enables DATA to drive out. If the AT17A Series is reset with nCS Low, the device initializes as the first (and master) device in a daisy-chain. If the AT17A Series is reset with nCS High, the device initializes as a subsequent AT17A Series device in the chain.
12	GND		Ground pin. A 0.2 μ F decoupling capacitor should be placed between the VCC and GND pins.
15	nCASC	O	Cascade select output (active Low). This output goes Low when the address counter has reached its maximum value. In a daisy-chain of AT17A Series devices, the nCASC pin of one device is usually connected to the nCS input pin of the next device in the chain, which permits DCLK from the master Configurator to clock data from a subsequent AT17A Series device in the chain.
	A2	I	Device selection input, A2. This is used to enable (or select) the device during programming, (i.e., when $\overline{SER_EN}$ is Low; please refer to the “Programming Specification” application note for more details).
20	READY	O	Open collector reset state indicator. Driven Low during power-up reset, released (tri-stated) when power-up is complete. (Recommend a 4.7 k Ω pull-up on this pin if used).
23	$\overline{SER_EN}$	I	Serial enable must be held High during FPGA loading operations. Bringing $\overline{SER_EN}$ Low, enables the 2-wire serial programming mode.
27	VCC		+3.3V/+5V power supply pin



Absolute Maximum Ratings*

Operating Temperature	-55°C to +125°C
Storage Temperature	-65°C to +150°C
Voltage on Any Pin with Respect to Ground	-0.1V to $V_{CC} + 0.5V$
Supply Voltage (V_{CC})	-0.5V to +7.0V
Maximum Soldering Temp. (10 sec @ 1/16 in.)	260°C

*NOTICE: Stresses beyond those listed under Absolute Maximum Ratings may cause permanent damage to the device. These are stress ratings only, and functional operation of the device at these or any other conditions beyond those listed under Operating Conditions is not implied. Exposure to Absolute Maximum Ratings conditions for extended periods of time may affect device reliability.

Operating Conditions

Symbol	Description		AT17C040A		AT17LV040A		Units
			Min	Max	Min	Max	
V_{CC}	Commercial	Supply voltage relative to GND -0°C to +70°C	4.75	5.25	3.15	3.45	V
	Industrial	Supply voltage relative to GND -40°C to +85°C	4.5	5.5	3.15	3.45	V
	Military	Supply voltage relative to GND -55°C to +125°C	4.5	5.5	3.15	3.45	V

DC Characteristics

 $V_{CC} = 5V \pm 5\%$ Commercial/ $5V \pm 10\%$ Industrial/Military

Symbol	Description		Min	Max	Units
V_{IH}	High-level Input Voltage		2.0	V_{CC}	V
V_{IL}	Low-level Input Voltage		0	0.8	V
V_{OH}	High-level Output Voltage ($I_{OH} = -4$ mA)	Commercial	3.86		V
V_{OL}	Low-level Output Voltage ($I_{OL} = +4$ mA)			0.32	V
V_{OH}	High-level Output Voltage ($I_{OH} = -4$ mA)	Industrial	3.76		V
V_{OL}	Low-level Output Voltage ($I_{OL} = +4$ mA)			0.37	V
V_{OH}	High-level Output Voltage ($I_{OH} = -4$ mA)	Military	3.7		V
V_{OL}	Low-level Output Voltage ($I_{OL} = +4$ mA)			0.4	V
I_{CCA}	Supply Current, Active Mode (at FMAX)			10	mA
I_L	Input or Output Leakage Current ($V_{IN} = V_{CC}$ or GND)		-10	10	μ A
I_{CCS}	Supply Current, Standby Mode AT17C040A	Commercial		0.5	mA
		Industrial/Military		0.5	mA

DC Characteristics

 $V_{CC} = 3.3V \pm 5\%$

Symbol	Description		Min	Max	Units
V_{IH}	High-level Input Voltage		2.0	V_{CC}	V
V_{IL}	Low-level Input Voltage		0	0.8	V
V_{OH}	High-level Output Voltage ($I_{OH} = -2.5$ mA)	Commercial	2.4		V
V_{OL}	Low-level Output Voltage ($I_{OL} = +3$ mA)			0.4	V
V_{OH}	High-level Output Voltage ($I_{OH} = -2$ mA)	Industrial	2.4		V
V_{OL}	Low-level Output Voltage ($I_{OL} = +3$ mA)			0.4	V
V_{OH}	High-level Output Voltage ($I_{OH} = -2$ mA)	Military	2.4		V
V_{OL}	Low-level Output Voltage ($I_{OL} = +2.5$ mA)			0.4	V
I_{CCA}	Supply Current, Active Mode (at FMAX)			5	mA
I_L	Input or Output Leakage Current ($V_{IN} = V_{CC}$ or GND)		-10	10	μ A
I_{CCS}	Supply Current, Standby Mode	Commercial		100	μ A
		Industrial/Military		100	μ A

AC Characteristics for AT17C040A

$V_{CC} = 5V \pm 5\%$ Commercial/ $V_{CC} = 5V \pm 10\%$ Industrial/Military

Symbol	Description	Commercial		Industrial/Military ⁽¹⁾		Units
		Min	Max	Min	Max	
$T_{OE}^{(2)}$	OE to Data Delay		30		35	ns
$T_{CE}^{(2)}$	nCS to Data Delay		45		45	ns
$T_{CAC}^{(2)}$	DCLK to Data Delay		50		55	ns
T_{OH}	Data Hold From nCS, OE, or DCLK	0		0		ns
$T_{DF}^{(3)}$	nCS or OE to Data Float Delay		50		50	ns
T_{LC}	DCLK Low Time Slave Mode	20		20		ns
T_{HC}	DCLK High Time Slave Mode	20		20		ns
T_{SCE}	nCS Setup Time to DCLK (to guarantee proper counting)	20		25		ns
T_{HCE}	nCS Hold Time from DCLK (to guarantee proper counting)	0		0		ns
T_{LOE}	OE Low Time (guarantees counter is reset)	20		20		ns
F_{MAX}	MAX Input Clock Frequency Slave Mode	15		10		MHz
T_{LC}	DCLK Low Time Master Mode	30	250	30	250	ns
T_{HC}	DCLK High Time Master Mode	30	250	30	250	ns

- Notes: 1. Preliminary specifications for military operating range only.
 2. AC test load = 50 pF.
 3. Float delays are measured with 5 pF AC loads. Transition is measured ± 200 mV from steady state active levels.

AC Characteristics for AT17C040A When Cascading

$V_{CC} = 5V \pm 5\%$ Commercial/ $V_{CC} = 5V \pm 10\%$ Industrial/Military

Symbol	Description	Commercial		Industrial/Military ⁽¹⁾		Units
		Min	Max	Min	Max	
$T_{CDF}^{(3)}$	DCLK to Data Float Delay		50		50	ns
$T_{OCK}^{(2)}$	DCLK to nCASC Delay		35		40	ns
$T_{OCE}^{(2)}$	nCS to nCASC Delay		35		35	ns
$T_{OOE}^{(2)}$	OE to nCASC Delay		30		30	ns
F_{MAX}	MAX Input Clock Frequency	12.5		12.5		MHz

- Notes: 1. Preliminary specifications for military operating range only.
 2. AC test load = 50 pF.
 3. Float delays are measured with 5 pF AC loads. Transition is measured ± 200 mV from steady state active levels.



AC Characteristics for AT17LV040A

$V_{CC} = 3.3V \pm 5\%$ Commercial/ $V_{CC} = 3.3V \pm 5\%$ Industrial/Military

Symbol	Description	Commercial		Industrial/Military ⁽¹⁾		Units
		Min	Max	Min	Max	
$T_{OE}^{(2)}$	OE to Data Delay		50		55	ns
$T_{CE}^{(2)}$	nCS to Data Delay		55		60	ns
$T_{CAC}^{(2)}$	DCLK to Data Delay		60		65	ns
T_{OH}	Data Hold From nCS, OE, or DCLK	0		0		ns
$T_{DF}^{(2)}$	nCS or OE to Data Float Delay		50		50	ns
T_{LC}	DCLK Low Time Slave Mode	25		25		ns
T_{HC}	DCLK High Time Slave Mode	25		25		ns
T_{SCE}	nCS Setup Time to DCLK (to guarantee proper counting)	35		40		ns
T_{HCE}	nCS Hold Time from DCLK (to guarantee proper counting)	0		0		ns
T_{LOE}	OE Low Time (guarantees counter is reset)	20		20		ns
F_{MAX}	MAX Input Clock Frequency Slave Mode	15		10		MHz
T_{LC}	DCLK Low Time Master Mode	30	300	30	300	ns
T_{HC}	DCLK High Time Master Mode	30	300	30	300	ns

- Notes: 1. Preliminary specifications for military operating range only.
2. AC test load = 50 pF.

AC Characteristics for AT17LV040A When Cascading

$V_{CC} = 3.3V \pm 5\%$ Commercial/ $V_{CC} = 3.3V \pm 5\%$ Industrial/Military

Symbol	Description	Commercial		Industrial/Military ⁽¹⁾		Units
		Min	Max	Min	Max	
$T_{CDF}^{(3)}$	DCLK to Data Float Delay		50		50	ns
$T_{OCK}^{(2)}$	DCLK to nCASC Delay		50		55	ns
$T_{OCE}^{(2)}$	nCS to nCASC Delay		35		40	ns
$T_{OOE}^{(2)}$	OE to nCASC Delay		35		35	ns
F_{MAX}	MAX Input Clock Frequency Slave Mode	12		10		MHz

- Notes: 1. Preliminary specifications for military operating range only.
2. AC test load = 50 pF.
3. Float delays are measured with 5 pF AC loads. Transition is measured ± 200 mV from steady state active levels.

Ordering Information - 5V Devices

Memory Size	Ordering Code	Package	Operation Range
4 M	AT17C040A-10QC	32T	Commercial (0°C to 70°C)
	AT17C040A10QI	32T	Industrial (-40°C to 85°C)

Ordering Information - 3.3V Devices

Memory Size	Ordering Code	Package	Operation Range
4 M	AT17LV040A-10QC	32T	Commercial (0°C to 70°C)
	AT17LV040A-10QI	32T	Industrial (-40°C to 85°C)

Package Type	
32T	32-lead, Thin Plastic Quad Flat Package (TQFP)



Packaging Information

32T, 32-Lead Plastic Thin Quad Flat Pack (TQFP)
 Dimensions in Inches and (Millimeters)

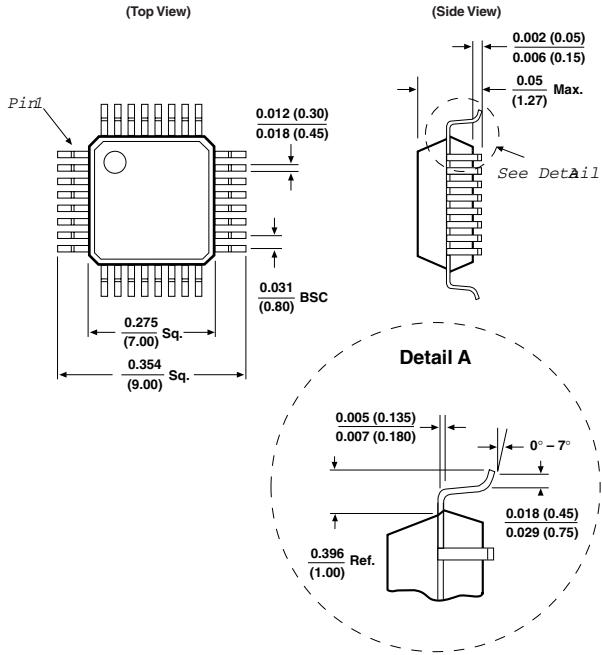



Atmel Headquarters

Corporate Headquarters

2325 Orchard Parkway
San Jose, CA 95131
TEL (408) 441-0311
FAX (408) 487-2600

Europe

Atmel SarL
Route des Arsenaux 41
Casa Postale 80
CH-1705 Fribourg
Switzerland
TEL (41) 26-426-5555
FAX (41) 26-426-5500

Asia

Atmel Asia, Ltd.
Room 1219
Chinachem Golden Plaza
77 Mody Road Tsimhatsui
East Kowloon
Hong Kong
TEL (852) 2721-9778
FAX (852) 2722-1369

Japan

Atmel Japan K.K.
9F, Tonetsu Shinkawa Bldg.
1-24-8 Shinkawa
Chuo-ku, Tokyo 104-0033
Japan
TEL (81) 3-3523-3551
FAX (81) 3-3523-7581

Atmel Operations

Atmel Colorado Springs

1150 E. Cheyenne Mtn. Blvd.
Colorado Springs, CO 80906
TEL (719) 576-3300
FAX (719) 540-1759

Atmel Rousset

Zone Industrielle
13106 Rousset Cedex
France
TEL (33) 4-4253-6000
FAX (33) 4-4253-6001

Atmel Smart Card ICs

Scottish Enterprise Technology Park
East Kilbride, Scotland G75 0QR
TEL (44) 1355-357-000
FAX (44) 1355-242-743

Atmel Grenoble

Avenue de Rochepleine
BP 123
38521 Saint-Egreve Cedex
France
TEL (33) 4-7658-3000
FAX (33) 4-7658-3480

Atmel Configurator Hotline

(408) 436-4118

Atmel Configurator e-mail

configurator@atmel.com

FAQ

Available on web site

Fax-on-Demand

North America:
1-(800) 292-8635
International:
1-(408) 441-0732

e-mail

literature@atmel.com

Web Site

<http://www.atmel.com>

BBS

1-(408) 436-4309

© Atmel Corporation 2001.

Atmel Corporation makes no warranty for the use of its products, other than those expressly contained in the Company's standard warranty which is detailed in Atmel's Terms and Conditions located on the Company's web site. The Company assumes no responsibility for any errors which may appear in this document, reserves the right to change devices or specifications detailed herein at any time without notice, and does not make any commitment to update the information contained herein. No licenses to patents or other intellectual property of Atmel are granted by the Company in connection with the sale of Atmel products, expressly or by implication. Atmel's products are not authorized for use as critical components in life support devices or systems.

FLEX is a registered trademark of Altera Corporation.

Terms and product names in this document may be trademarks of others.



Printed on recycled paper.