

## MM54C906/MM74C906 Hex Open Drain N-Channel Buffers MM54C907/MM74C907 Hex Open Drain P-Channel Buffers

### General Description

These buffers employ monolithic CMOS technology in achieving open drain outputs. The MM54C906/MM74C906 consists of six inverters driving six N-channel devices; and the MM54C907/MM74C907 consists of six inverters driving six P-channel devices. The open drain feature of these buffers makes level shifting or wire AND and wire OR functions by just the addition of pull-up or pull-down resistors. All inputs are protected from static discharge by diode clamps to  $V_{CC}$  and to ground.

### Features

- Wide supply voltage range
- Guaranteed noise margin
- High noise immunity
- High current sourcing and sinking open drain outputs

3V to 15V  
1V  
0.45  $V_{CC}$  (typ.)

### Connection and Logic Diagrams

Dual-In-Line Package

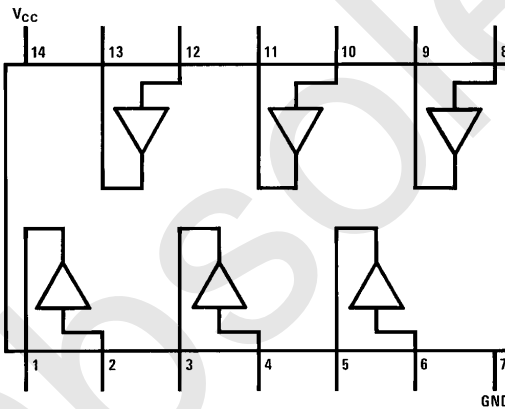

TL/F/5911-1

Top View

Order Number MM54C906, MM54C907, MM74C906 or MM74C907

MM54C906/MM74C906

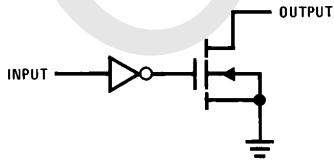

TL/F/5911-2

MM54C907/MM74C907

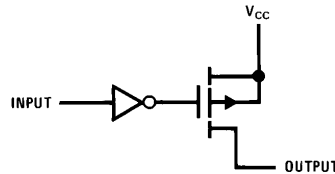

TL/F/5911-3

MM54C906/MM74C906 Hex Open Drain N-Channel Buffers  
MM54C907/MM74C907 Hex Open Drain P-Channel Buffers

## Absolute Maximum Ratings (Note 1)

If Military/Aerospace specified devices are required, please contact the National Semiconductor Sales Office/Distributors for availability and specifications.

Voltage at Any Input Pin	-0.3V to $V_{CC} + 0.3V$
Voltage at Any Output Pin	-0.3V to +18V
MM54C906/MM74C906	$V_{CC} - 18$ to $V_{CC} + 0.3V$
MM54C907/MM74C907	
Operating Temperature Range	-55°C to +125°C
MM54C906/MM54C907	-40°C to +85°C
MM74C906/MM74C907	

Storage Temperature Range	-65°C to +150°C
Power Dissipation	
Dual-In-Line	700 mW
Small Outline	500 mW
Operating $V_{CC}$ Range	3V to 15V
Absolute Maximum $V_{CC}$	18V
Lead Temperature ( $T_L$ )	260°C
(Soldering, 10 seconds)	

## DC Electrical Characteristics Min/Max limits apply across temperature range unless otherwise noted

Symbol	Parameter	Conditions	Min	Typ	Max	Units
<b>CMOS TO CMOS</b>						
$V_{IN(1)}$	Logical "1" Input Voltage	$V_{CC} = 5V$ $V_{CC} = 10V$	3.5 8.0			V V
$V_{IN(0)}$	Logical "0" Input Voltage	$V_{CC} = 5V$ $V_{CC} = 10V$			1.5 2	V V
$I_{IN(1)}$	Logical "1" Input Current	$V_{CC} = 15V, V_{IN} = 15V$		0.005	1	$\mu A$
$I_{IN(0)}$	Logical "0" Input Current	$V_{CC} = 15V, V_{IN} = 0V$	-1.0	-0.005		$\mu A$
$I_{CC}$	Supply Current	$V_{CC} = 15V, \text{Output Open}$		0.05	15	$\mu A$
	Output Leakage					
	MM54C906	$V_{CC} = 4.5V, V_{IN} = V_{CC} - 1.5V$ $V_{CC} = 4.5V, V_{OUT} = 18V$		0.005	5	$\mu A$
	MM74C906	$V_{CC} = 4.75V, V_{IN} = V_{CC} - 1.5V$ $V_{CC} = 4.75V, V_{OUT} = 18V$		0.005	5	$\mu A$
	MM54C907	$V_{CC} = 4.5V, V_{IN} = 1V + 0.1 V_{CC}$ $V_{CC} = 4.5V, V_{OUT} = V_{CC} - 18V$		0.005	5	$\mu A$
	MM74C907	$V_{CC} = 4.75V, V_{IN} = 1V + 0.1 V_{CC}$ $V_{CC} = 4.75V, V_{OUT} = V_{CC} - 18V$		0.005	5	$\mu A$
<b>CMOS/LPTTL INTERFACE</b>						
$V_{IN(1)}$	Logical "1" Input Voltage	54C, $V_{CC} = 4.5V$ 74C, $V_{CC} = 4.75V$	$V_{CC} - 1.5V$ $V_{CC} - 1.5V$			V V
$V_{IN(0)}$	Logical "0" Input Voltage	54C, $V_{CC} = 4.5V$ 74C, $V_{CC} = 4.75V$			0.8 0.8	V V
<b>OUTPUT DRIVE CURRENT</b>						
	MM54C906	$V_{CC} = 4.5V, V_{IN} = 1V + 0.1 V_{CC}$ $V_{CC} = 4.5V, V_{OUT} = 0.5V$ $V_{CC} = 4.5V, V_{OUT} = 1.0V$	2.1 4.2	8.0 12.0		mA mA
	MM74C906	$V_{CC} = 4.75V, V_{IN} = 1V + 0.1 V_{CC}$ $V_{CC} = 4.75V, V_{OUT} = 0.5V$ $V_{CC} = 4.75V, V_{OUT} = 1.0V$	2.1 4.2	8.0 12.0		mA mA
	MM54C907	$V_{CC} = 4.5V, V_{IN} = V_{CC} - 1.5V$ $V_{CC} = 4.5V, V_{OUT} = V_{CC} - 0.5V$ $V_{CC} = 4.5V, V_{OUT} = V_{CC} - 1V$	-1.05 -2.1	-1.5 -3.0		mA mA
	MM74C907	$V_{CC} = 4.75V, V_{IN} = V_{CC} - 1.5V$ $V_{CC} = 4.75V, V_{OUT} = V_{CC} - 0.5V$ $V_{CC} = 4.75V, V_{OUT} = V_{CC} - 1V$	-1.05 -2.1	-1.5 -3.0		mA mA
	MM54C906/MM74C906	$V_{CC} = 10V, V_{IN} = 2V$ $V_{CC} = 10V, V_{OUT} = 0.5V$ $V_{CC} = 10V, V_{OUT} = 1V$	4.2 8.4	-20 -30		mA mA
	MM54C907/MM74C907	$V_{CC} = 10V, V_{IN} = 8V$ $V_{CC} = 10V, V_{OUT} = 9.5V$ $V_{CC} = 10V, V_{OUT} = 9V$	-2.1 -4.2	-4.0 -8.0		mA mA

## AC Electrical Characteristics\* $T_A = 25^\circ\text{C}$ , $C_L = 50\text{ pF}$ , unless otherwise specified

Symbol	Parameter	Conditions	Min	Typ	Max	Units
$t_{pd}$	Propagation Delay Time to a Logical "0" MM54C906/MM74C906	$V_{CC} = 5.0\text{V}$ , $R = 10\text{k}$			150	ns
		$V_{CC} = 10\text{V}$ , $R = 10\text{k}$			75	ns
	MM54C907/MM74C907	$V_{CC} = 5.0\text{V}$ (Note 4)			$150 + 0.7 RC$	ns
		$V_{CC} = 10\text{V}$ (Note 4)			$75 + 0.7 RC$	ns
$t_{pd}$	Propagation Delay Time to a Logical "1" MM54C906/MM74C906	$V_{CC} = 5.0\text{V}$ (Note 4)			$150 + 0.7 RC$	ns
		$V_{CC} = 10\text{V}$ (Note 4)			$75 + 0.7 RC$	ns
	MM54C907/MM74C907	$V_{CC} = 5.0\text{V}$ , $R = 10\text{k}$			150	ns
		$V_{CC} = 10\text{V}$ , $R = 10\text{k}$			75	ns
$C_{IN}$	Input Capacitance	(Note 2)		5.0		pF
$C_{OUT}$	Output Capacity	(Note 2)		20		pF
$C_{PD}$	Power Dissipation Capacity	(Note 3) Per Buffer		30		pF

\*AC Parameters are guaranteed by DC correlated testing.

**Note 1:** "Absolute Maximum Ratings" are those values beyond which the safety of the device cannot be guaranteed. Except for "Operating Temperature Range" they are not meant to imply that the devices should be operated at these limits. The table of "Electrical Characteristics" provides conditions for actual device operation.

**Note 2:** Capacitance is guaranteed by periodic testing.

**Note 3:**  $C_{PD}$  determines the no load AC power consumption of any CMOS device. For complete explanation see 54C/74C Family Characteristics Application Note, AN-90. (Assumes outputs are open).

**Note 4:** "C" used in calculating propagation includes output load capacity ( $C_L$ ) plus device output capacity ( $C_{OUT}$ ).

## Typical Applications

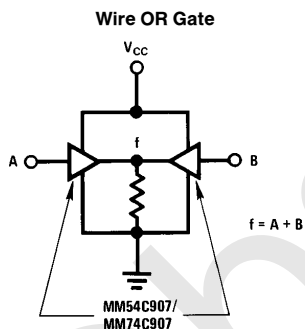

TL/F/5911-4

**Note:** Can be extended to more than 2 inputs.

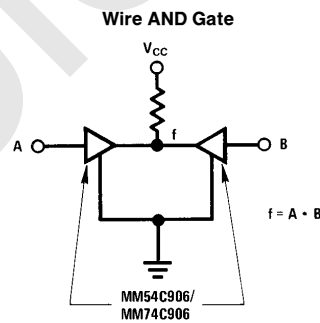

TL/F/5911-5

**Note:** Can be extended to more than 2 inputs.

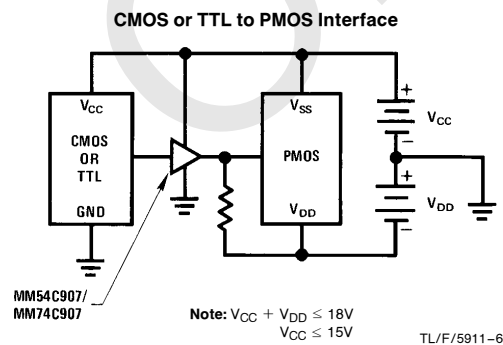

TL/F/5911-6

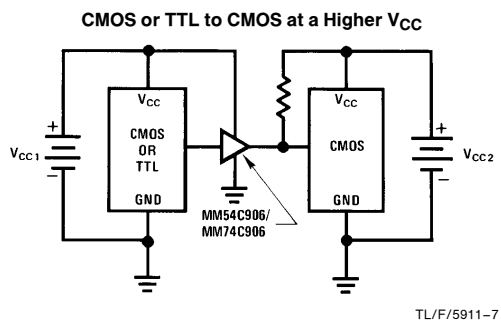

TL/F/5911-7

**MM54C906/MM74C906 Hex Open Drain N-Channel Buffers  
MM54C907/MM74C907 Hex Open Drain P-Channel Buffers**

**Physical Dimensions** inches (millimeters)

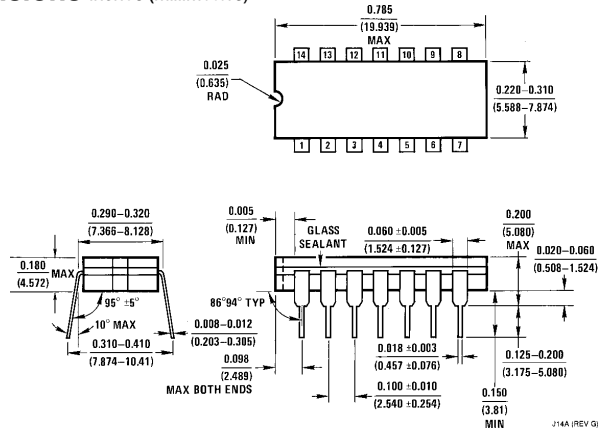

**Ceramic Dual-In-Line Package (J)**

Order Number **MM54C906J, MM54C907J, MM74C906J, MM74C907J**  
NS Package Number **J14A**

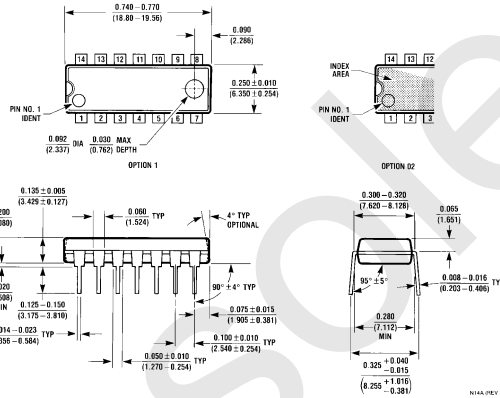

**Molded Dual-In-Line Package (N)**

Order Number **MM54C906N, MM54C907N, MM74C906N or MM74C907N**  
NS Package Number **N14A**

**LIFE SUPPORT POLICY**

NATIONAL'S PRODUCTS ARE NOT AUTHORIZED FOR USE AS CRITICAL COMPONENTS IN LIFE SUPPORT DEVICES OR SYSTEMS WITHOUT THE EXPRESS WRITTEN APPROVAL OF THE PRESIDENT OF NATIONAL SEMICONDUCTOR CORPORATION. As used herein:

1. Life support devices or systems are devices or systems which, (a) are intended for surgical implant into the body, or (b) support or sustain life, and whose failure to perform, when properly used in accordance with instructions for use provided in the labeling, can be reasonably expected to result in a significant injury to the user.
2. A critical component is any component of a life support device or system whose failure to perform can be reasonably expected to cause the failure of the life support device or system, or to affect its safety or effectiveness.



**National Semiconductor Corporation**  
1111 West Bardin Road  
Arlington, TX 76017  
Tel: (800) 272-9959  
Fax: (800) 737-7018

**National Semiconductor Europe**  
Fax: (+49) 0-180-530 85 86  
Email: [cnjwge@tevm2.nsc.com](mailto:cnjwge@tevm2.nsc.com)  
Deutsch Tel: (+49) 0-180-530 85 85  
English Tel: (+49) 0-180-532 78 32  
Français Tel: (+49) 0-180-532 93 58  
Italiano Tel: (+49) 0-180-534 16 80

**National Semiconductor Hong Kong Ltd.**  
19th Floor, Straight Block,  
Ocean Centre, 5 Canton Rd.  
Tsimshatsui, Kowloon  
Hong Kong  
Tel: (852) 2737-1600  
Fax: (852) 2736-9960

**National Semiconductor Japan Ltd.**  
Tel: 81-043-299-2309  
Fax: 81-043-299-2408

National does not assume any responsibility for use of any circuitry described, no circuit patent licenses are implied and National reserves the right at any time without notice to change said circuitry and specifications.