

5

4

3

2

1

受控 CONTROLLED DOCUMENT

编号 P/N	26-8012-CUST	版本 Rev	01	日期 Rel'd Date	SEP 17,09
-----------	--------------	-----------	----	------------------	-----------

Description: N (M) TO N (F) RA UG-27/U

Part No: 26-8012

Application: Adapter

Crimp Tool: N/A

Impedance: N/A

Frequency Range: N/A

Material: Body Brass Nickel Plated

Nut Brass Nickel Plated

Insulator PTFE

Contact Brass Gold Plated

RoHS Compliance: Yes

Technical Detail: Refer to Emerson Document P/N 26-0000



DRAWING NO.

26-8012

REVISIONS

01	OFFICIAL RELEASE				Betty 2009.09.16 11:01:39 +0800©
	08-05-09	I	W	T	

D

D

C

C

B

B

A

A

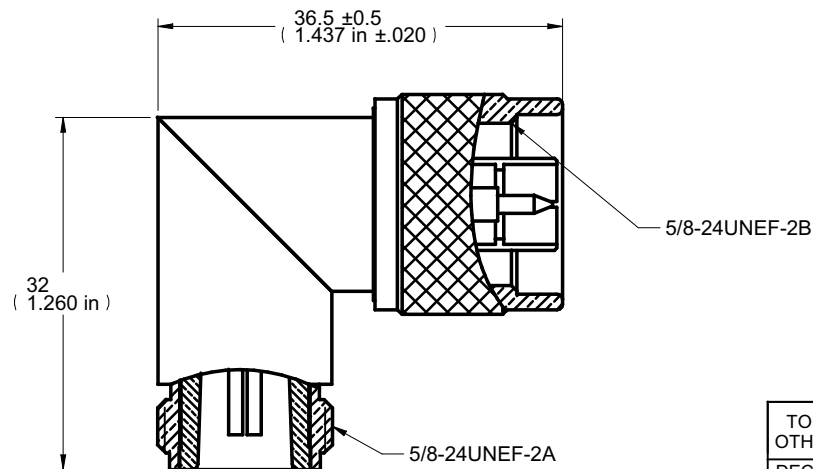
**DIM OUTLINE**

CUSTOMER COPY

TOLERANCE UNLESS OTHERWISE SPECIFIED		DRAWN BY IVON.W	DATE 08-05-09
DECIMALS	mm	CHECKED BY IVON.W	DATE 08-05-09
X	± 0.5	APPROVED BY THOMAS	DATE 08-05-09
X.X	± 0.3		
X.XX	± 0.1		
ANGLES	± 0.5°	U/M	mm

TITLE
N (M) TO N (F) RA UG-27/USHEET
1 OF 1DRAWING NO.
26-8012SIZE
ATHIS DRAWING WAS PRODUCED BY COMPUTER,
DO NOT SCALE DRAWING OR UPDATE MANUALLY.

5

4

3

2

1