



VOICE RECORDER CONTROLLER

GENERAL DESCRIPTION

The W5120 is a voice recorder IC that contains A/D and D/A converters to digitize and reproduce voice signals. It is easy to use for both record and playback operations. The maximum recording time is unlimited, and depends only on the size of the external memory.

The W5120 is a voice recorder controller which includes a microphone preamplifier, AGC, anti-aliasing/smoothing filters, A/D, D/A, speaker amplifier, and timing/logic control circuits. The serial SRAM is a memory device used for data storage and retrieval.

The chip's flexible architecture simplifies record and playback operations by providing flexible segmentation, memory cascading, and other functions. This product can be used in message reminders, greeting cards, alarm clocks, toys, and many other applications.

FEATURES

General

- Modified ADM algorithm
- Operates with Winbond's serial SRAMs
- Built-in A/D, D/A converters
- Built-in microphone preamplifier and speaker power amplifier
- Built-in automatic gain control (AGC) circuit and anti-aliasing/smoothing filter
- LED indicator
- Voice-activated recording (VOX)
- Microphone or line input for recording
- Provides both speaker direct drive and speaker current output (3 mA)
- Input trigger pins (REC, PLAY, RESET, FWD, SHIFT, STOP) debounced to ensure noise-free operation
- Sampling frequency (F_s) is adjustable through the external system clock resistor R_{OSC}

Single-segment Recorder

- One voice recording segment only
- Cascadable for longer duration (direct cascading of serial SRAMs)
- Operated by edge-triggered REC
- Provides silence auto-stop function to reduce MIC bias consumption
- Recording starts at
 - Beginning of the serial SRAM



- Recording stops when
 - A defined period of consecutive silence (about 3 seconds) is detected (silence auto-stop)
 - Serial SRAM overflows
 - Another REC is received during recording

Multi-segment Recorder

- Provides a maximum of 63 voice recording segments
- Up to two serial SRAMs can be cascaded easily
- Operated by level-triggered REC
- Provides consecutive recording as long as the RESET trigger is not activated
- Provides a silence extraction function to save memory space
- Provides two types of overflow prevention:
 - Serial SRAM overflow
 - Segment index overflow

Previous messages will be protected when overflow occurs, so that the new messages cannot be recorded. Overflow prevention can be released by pressing the RESET pin.
- Each time the PLAY pin is triggered, playback will skip to the next message
- Recording starts at
 - Beginning of the serial SRAM when device is powered on or RESET is pressed
 - End of previous message if overflow has not occurred
- Recording stops when
 - Falling edge of REC trigger is detected
 - Serial SRAM overflows



PIN CONFIGURATION

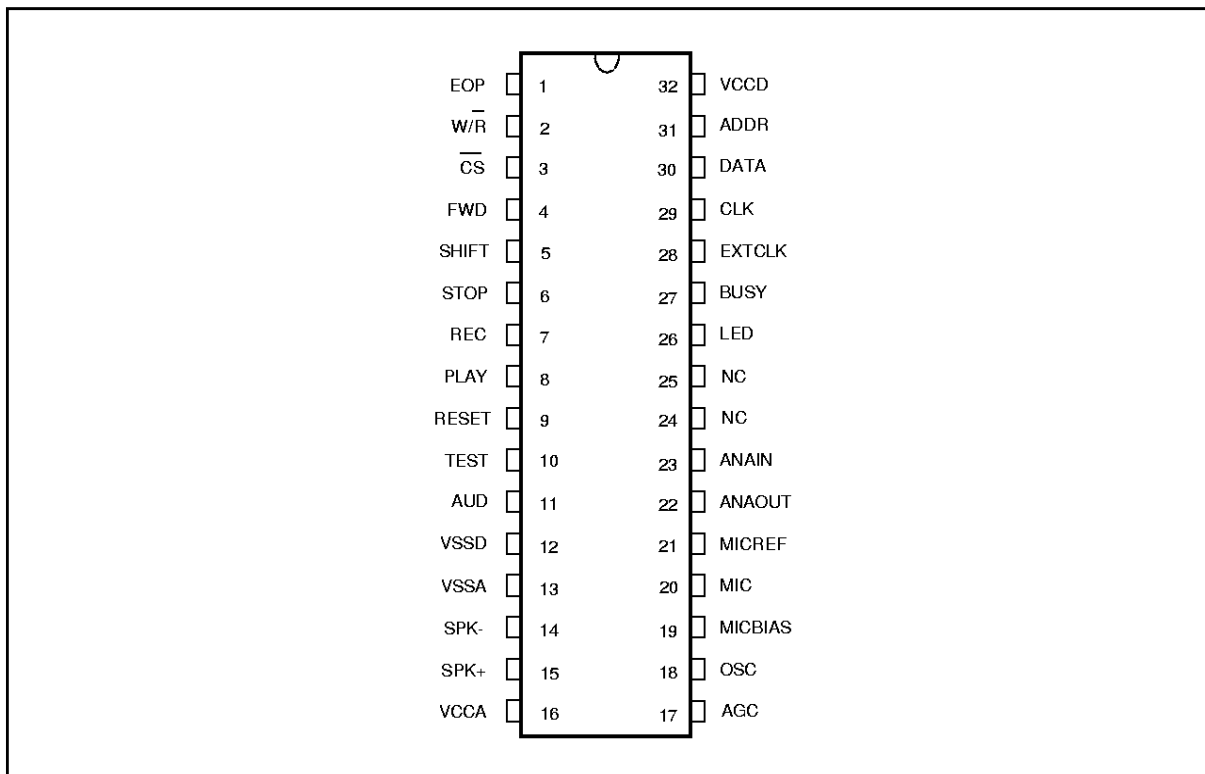

PIN DESCRIPTION

NO.	PIN	I/O	DESCRIPTION
1	EOP	I	End of playback signal for SSRAM interface
2	W/ \bar{R}	O	Write/Read control for SSRAM, W/ \bar{R} = VDD for write, W/ \bar{R} = Vss for read
3	\bar{CS}	O	Chip select for SSRAM
4	FWD	I	Message forward control key
5	SHIFT	I	Shift key for alternate functions
6	STOP	I	Active-high stop input for playback operations
7	REC	I	"RECORD" key, active high
8	PLAY	I	"PLAY" key, active high
9	RESET	I	"RESET" key, active high
10	TEST	I	Test pin
11	AUD	O	3 mA speaker current output
12	VSSD	-	Digital negative power supply



Pin Description, continued

NO.	PIN	I/O	DESCRIPTION
13	VSSA	-	Analog negative power supply
14	SPK-	O	Speaker power amplifier output -
15	SPK+	O	Speaker power amplifier output +
16	VCCA	-	Analog positive power supply
17	AGC	I	Automatic Gain Control input
18	OSC	I	Oscillation frequency control pin
19	MICBIAS	O	Microphone bias output
20	MIC	I	Microphone input
21	MICREF	I	Microphone reference
22	ANAOUT	O	Pre-amplifier output
23	ANAIN	I	Line input or AC coupled from ANAOUT
24	NC	-	No connection
25	NC	-	No connection
26	LED	O	LED indicator: On when recording, flashes when playing
27	BUSY	O	Busy output signal: On when playing
28	EXTCLK	I	External clock input
29	CLK	O	Data clock pin for SSRAM
30	DATA	I/O	Bidirectional data pin for SSRAM
31	ADDR	O	Address initialization clock pin for SSRAM
32	VCCD	-	Digital positive power supply

BLOCK DIAGRAM

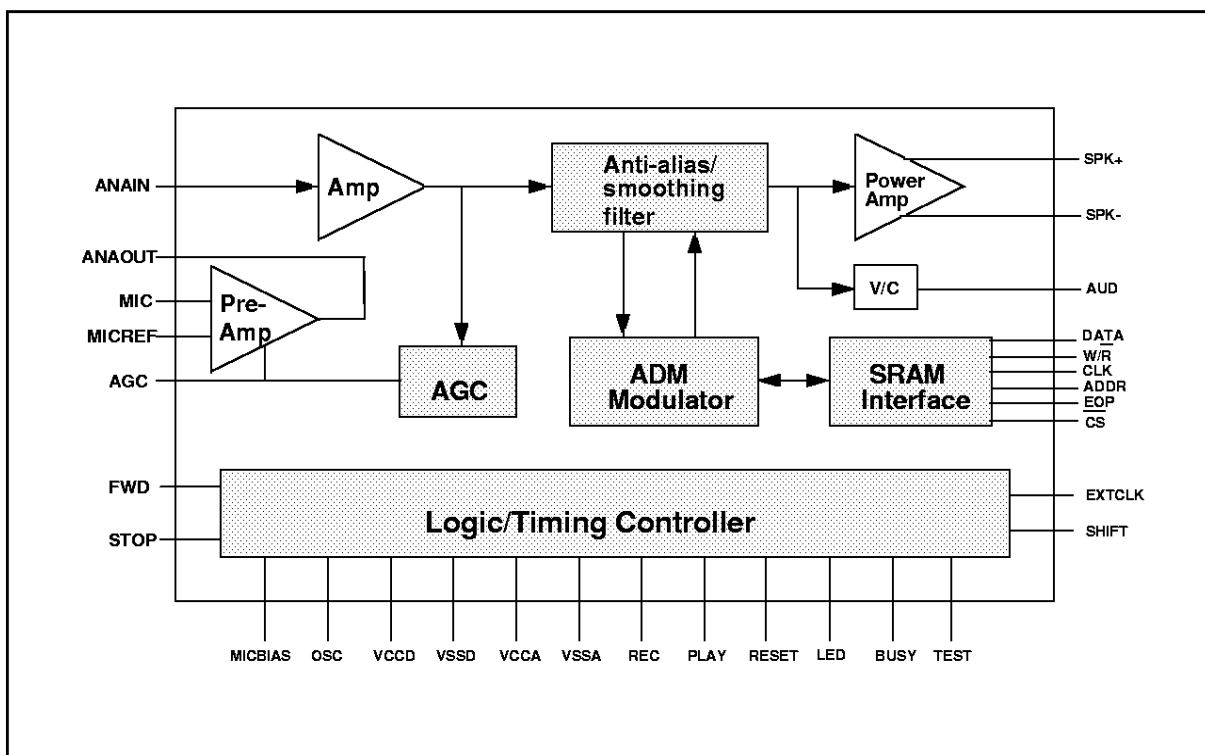

FUNCTIONAL DESCRIPTION

1. Single/Multi-segment Operation

The W5120 is typically used for either single or multi-segment operations.

Single Segment

Only one segment can be recorded and the storage duration can be extended by cascading serial SRAMs; up to 64 units of 256-Kbit serial SRAMs can be employed for a total of 16 Mbits of memory space.

Multi-segment

A maximum of 63 voice segments can be recorded into up to two 256-Kbit serial SRAMs and then played back. Subsequent recording will start operation directly after the last recorded message. Several input trigger pins (REC, PLAY, RESET, SHIFT, STOP, FWD) are used to operate the chip. When more than one message segment has been recorded, users can press the PLAY key to play back the messages one by one. While a message is playing back, pressing PLAY will cause the device to skip to the next message. When the last recorded message is reached, a subsequent PLAY will rewind the message pointer to the first message. The FWD key can also be used to cause the



message pointer to skip to the next message without playing back, but cannot rewind to the first message when the last message is reached.

2. Silence Extraction

In multi-segment operation a silence extraction function is used to extract silence between consecutive messages in order to save memory space. A length of silence that exceeds the threshold, T_{EXT} , will be extracted automatically. A length of silence shorter than T_{EXT} will be preserved without any change. The silence extraction function is illustrated in the following diagram.

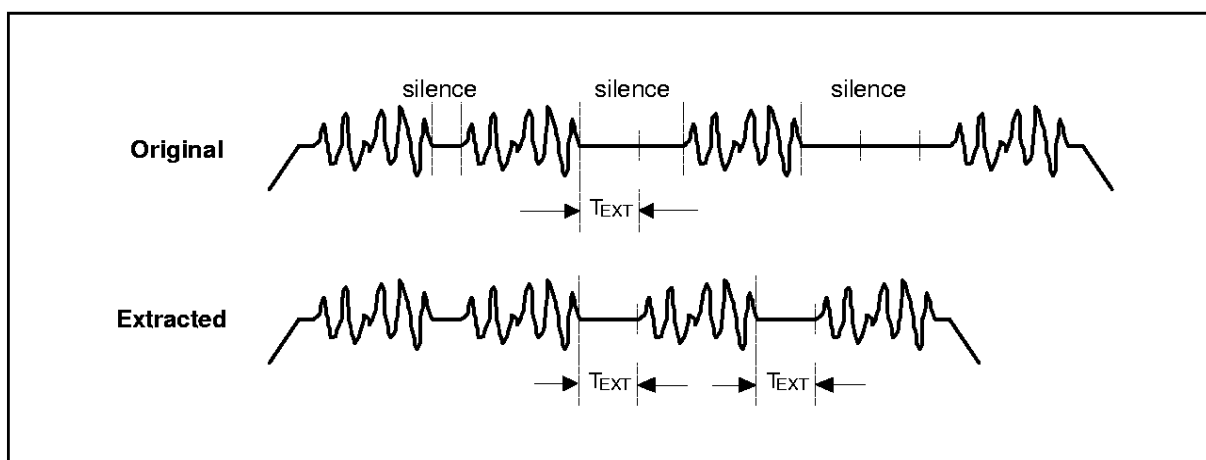

3. Silence Auto-stop

The silence auto-stop is turned on in edge-triggered recording to reduce possible MIC bias consumption when the input signal is off. If length of silence in the input signal exceeds T_{STOP} , the W5120 will be stopped entirely. Silence extraction and auto-stop are illustrated in the following diagram. The relationship between T_{EXT} and T_{STOP} is $T_{STOP} = 3 * T_{EXT}$.

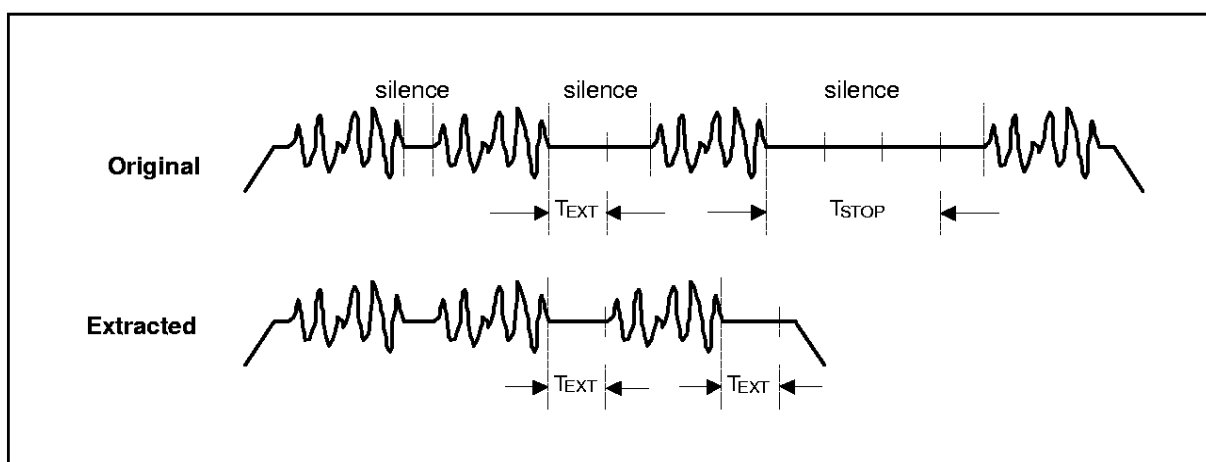

4. VOX

VOX is a voice-activated recording feature. The W5120 does not begin recording until a start signal sent by the AGC circuit is detected, indicating a predetermined threshold, $V_{AGC} = 2.0V$, has been reached. This function is depicted as follows.

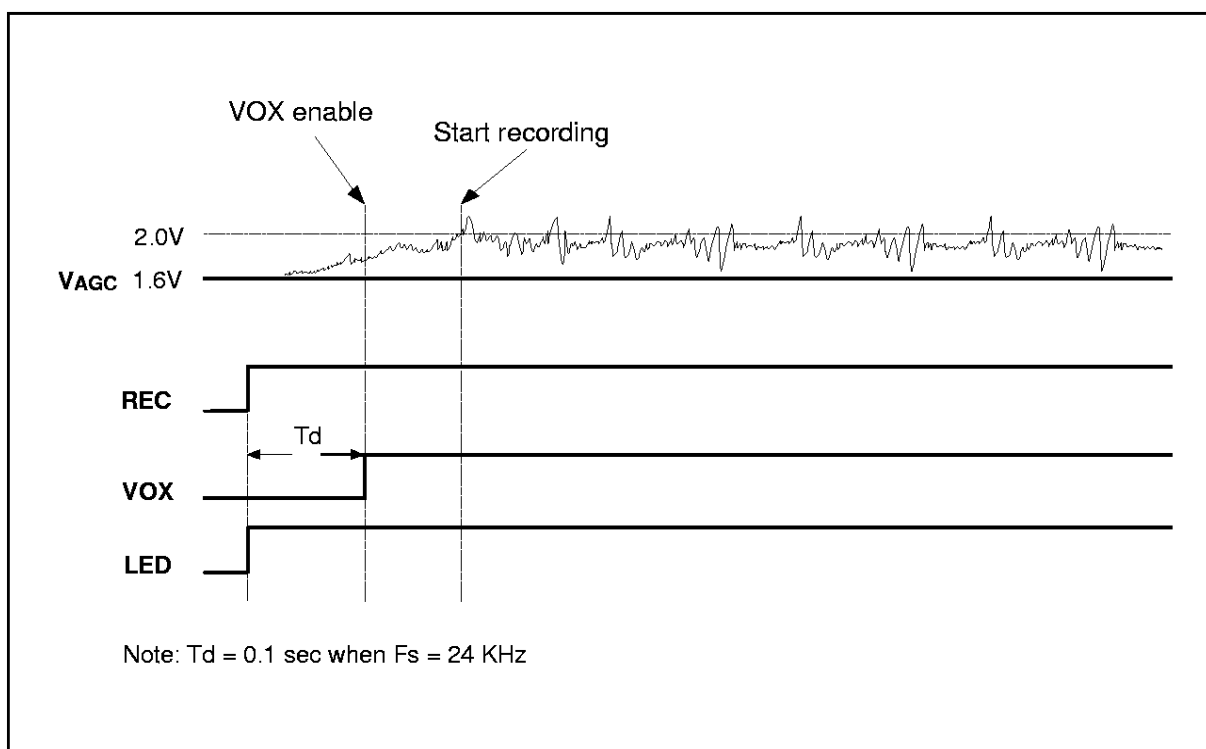

5. 3 mA Speaker Current Output

The W5120 provides two types of speaker drivers, direct drive and current output. The direct drive is a voltage output that comes from built-in power amplifier. The user can use this output to drive a speaker directly without any extra components, such as resistor or transistor. The maximum driving current will be 56 mA (rms) when connected to a 16Ω speaker. The current output is the same as the standard speaker driver used in most Winbond speech synthesizers. This option allows the W5120 to be used in conjunction with Winbond speech synthesizers for a variety of applications.

6. Sampling Frequency Adjustment

Customers can adjust the external R_{OSC} to change the system clock (F_{OSC}) and sampling frequency (F_s). The relationship between F_{OSC} and F_s is $F_s = F_{OSC}/32$. The relationship between F_s and R_{OSC} is shown below.

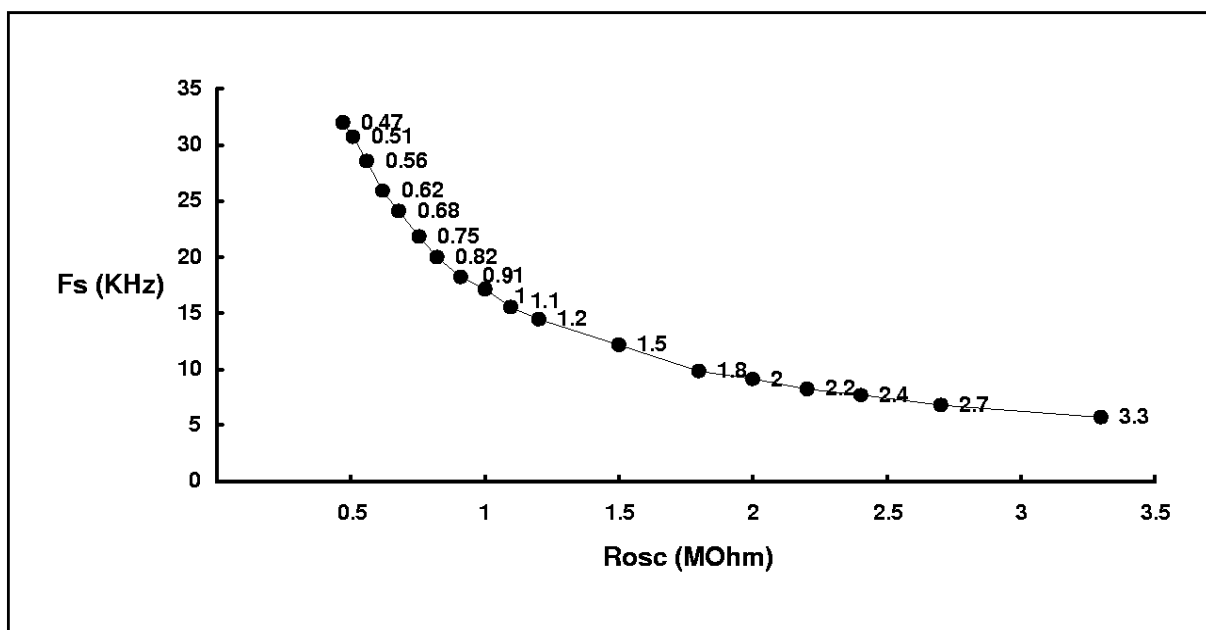

7. SSRAM Interface

There are six pins that work as a serial interface for communication with a Winbond-manufactured serial SRAM. The functions of these pins are as follows:

- Data:** This is a bidirectional pin used to transmit/receive data to/from the serial SRAM for writing/reading ADM data during record/playback and writing/reading addresses for control purposes.
- CLK:** This pin is used to provide the required clock signals for writing/reading data to/from the SRAM. Both the ADM data and control data need to be clocked into the serial SRAM.
- ADDR:** The ADDR pin is used to clock address data into the address counter, which is a 24-bit shift register/up-counter. The W5120 will send 24 clocks to the SRAM to write the address.
- EOP:** This signal is used for overflow indication. It is an input signal from the serial SRAM combination (single or cascaded). It will be issued when the end of memory is reached during record/playback operation. A high pulse of about 100 nS is used to indicate overflow condition in playback operation, while a high level is issued in recording operation when overflow occurs.
- $\overline{\text{CS}}$:** This is a chip select pin used only in a multi-segment recorder with two serial SRAMs cascaded. In other applications, this pin should be left floating and the corresponding $\overline{\text{CS}}$ pin of the serial SRAM should be grounded.
- $\overline{\text{W/R}}$:** A high level selects a write operation, while a low level selects a read operation.



8. LED Indicator

When the W5120 is in record mode, the LED is on. When the W5120 is in playback mode, the LED flashes.

9. Shift Function Key

Pressing the shift key enables several extra functions. These are described below:

SHIFT + FWD: This is the opposite of FWD. The message pointer will shift to the previous message.

SHIFT + PLAY: This combination causes the W5120 to play back all recorded messages continuously from the first message to the last message.

ABSOLUTE MAXIMUM RATINGS

PARAMETER	SYMBOL	RATING	UNIT
Supply Voltage	V _{DD} -V _{SS}	-0.3 to +7.0	V
Input Voltage	V _I	V _{SS} -0.3 to V _{DD} +0.3	V
Operating Temperature	T _A	0 to +70	°C
Storage Temperature	T _S	-55 to +150	°C

Note: Exposure to conditions beyond those listed under Absolute Maximum Ratings may adversely affect the life and reliability of the device.

DC CHARACTERISTICS

T_A = 25° C, V_{DD} = 5.0V

PARAMETER	SYMBOL	CONDITIONS	MIN.	TYP.	MAX.	UNIT
Operating Voltage	V _{DD}	-	3.6	4.5	5.5	V
Input High Voltage	V _{IH}	-	2.0	-	-	V
Input Low Voltage	V _{IL}	-	-	-	0.8	V
Input High Current for Digital	I _{IH}	V _{IN} = 5V	8	12	15	μA
Input Leakage Current	I _{IL}	V _{IN} = 0V	-	-	0.1	μA
Output High Current	I _{OH}	V _{OUT} = 4.5V	-3.5	-	-	mA
Output Low Current	I _{OL}	V _{OUT} = 0.5V	6	-	-	mA
Operating Current	I _{OP}	R _{EXT} = ∞, EOP = 0V	-	-	25	mA
Standby Current	I _{SB}	EOP = 0V	-	-	1	μA
Oscillation Frequency	F _{OSC}	R _{OSC} = 680 KΩ	-	768	-	KHz



AC CHARACTERISTICS

TA = 25° C, VDD = 5.0V

PARAMETER	SYMBOL	CONDITIONS	MIN.	TYP.	MAX.	UNIT
Input Debounce Time	TDEB	FOSC = 768 KHz Fs = 24 KHz	15	24	32	mS
Silence Extraction Criterion	TEXT		-	1	-	S
Silence Auto-stop Criterion	TSTOP		-	3	-	S
ADDR Period	TADDR		-	31.25	-	μS
CLK Period	TCLK		-	31.25	-	μS

ANALOG CIRCUIT CHARACTERISTICS

TA = 25° C, VDD = 5.0V

PARAMETER	SYMBOL	CONDITIONS	MIN.	TYPE	MAX.	UNIT
MIC Input Voltage	VIN1	Peak-peak	-	-	20	mV
ANAIN Input Voltage	VIN2	Peak-peak	-	-	160	mV
Passband of LPF	BW	FOSC = 768 KHz	-	3.5	-	KHz
Speaker Output Power	POUT	REXT = 16Ω, RMS	-	-	50	mW
Voltage Across Speaker Pins	VOUT	REXT = 600Ω	-	-	1.2	VP-P
Preamplifier Gain 1	G1	AGC = 1.6V	-	27	-	dB
Preamplifier Gain 2	G2	AGC = 2.8V	-	21	-	dB
Amplifier	G3		-	20	-	dB
Input Resistance of ANAIN	RANAIN		-	2.7	-	KΩ
Input Resistance of MIC	RMIC		-	10	-	KΩ
Input Resistance of AGC	RAGC		-	5	-	KΩ
Speaker Resistance	RSP		8	16	-	Ω



TYPICAL APPLICATION CIRCUIT

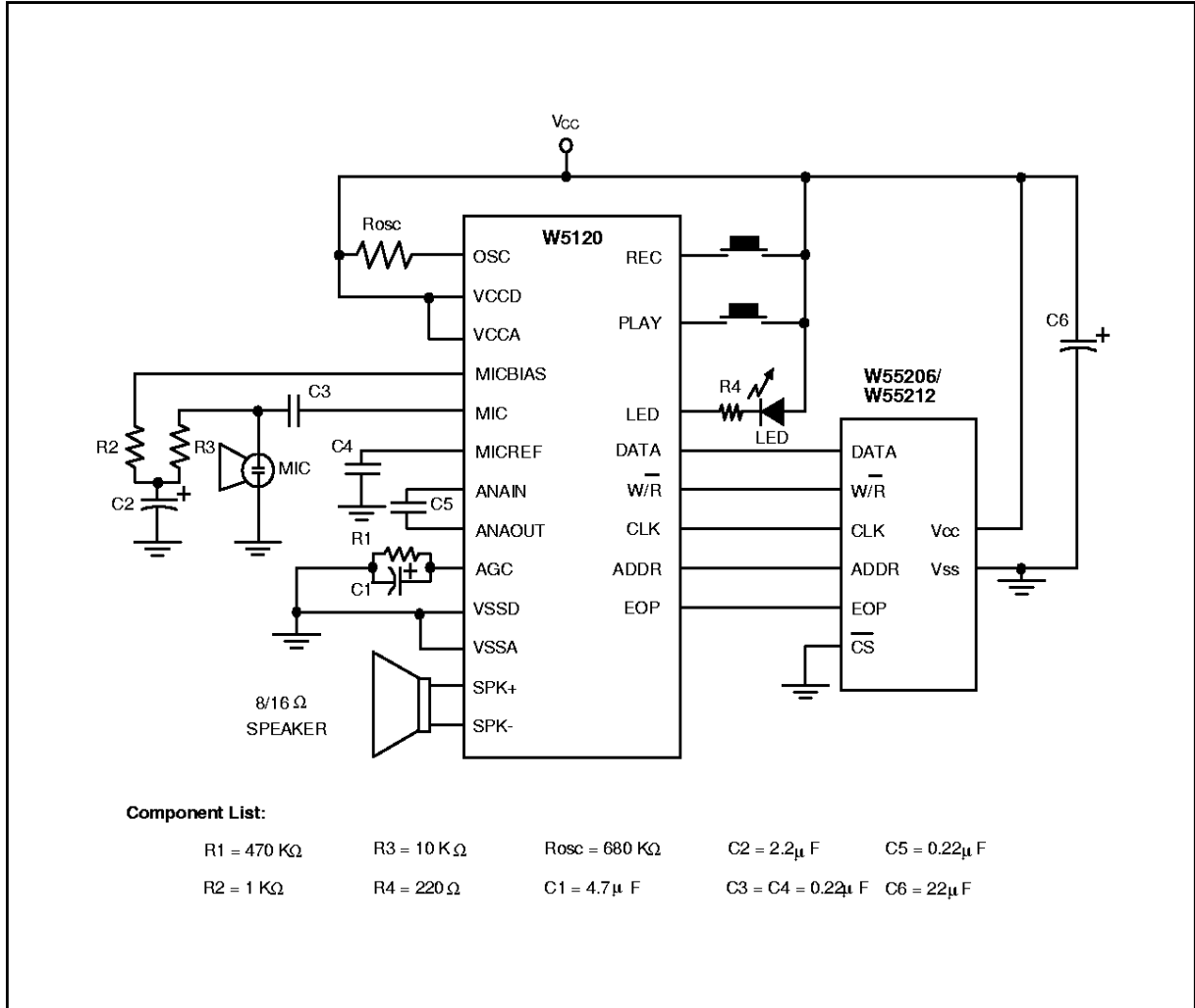

Notes:

1. R1, C1 can be adjusted for different AGC attack time and release time.
2. Set C3 = C4 to reduce ground noise.



Ordering Information

TYPE NO.	FUNCTION
W51205903	Single-segment operation
	Edge-triggered REC with silence auto stop
	No silence extraction
W51205901	Multi-segment operation
	Level-triggered REC without silence auto stop
	With silence extraction



Headquarters

No. 4, Creation Rd. III,
Science-Based Industrial Park,
Hsinchu, Taiwan
TEL: 886-3-6770066
FAX: 886-3-6792697

<http://www.winbond.com.tw/>

Voice & Fax on-demand: 886-2-7137006

Taipei Office

11F, No. 116, Sec. 3, Min-Sheng East Rd.,
Taipei, Taiwan
TEL: 886-2-71 90805
FAX: 886-2-71 97602

Winbond Electronics (H.K.) Ltd.

Rm. 803, World Trade Square, Tower II,
120 Hoi Bun Rd., Kwun Tong,
Kowloon, Hong Kong
TEL: 852-27513108
FAX: 852-27562664

Winbond Electronics North America Corp.

Winbond Memory Lab.
Winbond Microelectronics Corp.
Winbond Systems Lab.

2750 Orchard Parkway, San Jose,
CA 95134, U.S.A.
TEL: 1-408-9438866
FAX: 1-408-9436668

Note: All data and specifications are subject to change without notice.