

Preliminary

Features

- Fast Access Time Selection: 100ns/120ns/150ns
- Low Operating Current: 25 mA Max.
- Low Standby Current: 100µA Max.
- Commercial, Industrial and Military Temperature Range Selections
- 883 Qualified Version: 883/23C128M
- 28 Pin JEDEC Approved Pinout: Compatible with 27128 EPROMs and 23128 NMOS ROMs
- Mask-programmable Chip Select ($\overline{CS1}/\overline{CS1}^*$)
- Mask-programmable Output Enable ($\overline{OE}/\overline{OE}^*$)
- Mask-programmable Chip Enable ($\overline{CE}/\overline{CE}^*$) with Power Down Feature
- Single 5V ± 10% Supply
- Completely Static Operation
- Three-State Outputs for Direct Bus Interface
- Completely TTL Compatible

Description

The Solid State Scientific SCM23C128 is a high performance 131,072 bit static Read Only Memory (ROM) organized 16,384 words by eight bits and is fabricated using the SSS scaled silicon gate CMOS process, HCMOS II. With HCMOS II, all the operating features of NMOS ROMs are achieved (high speed, density, TTL compatibility), but with the added benefit of low CMOS operating power (approx. 1/10 the equivalent NMOS power).

The SCM23C128 operates from a single 5 Volt supply and features fully static operation requiring no clock. Three mask-programmable "chip selects" are provided (\overline{OE} , \overline{CE} , $\overline{CS1}$) for system expansion and output bus control. The Output Enable input ($\overline{OE}/\overline{OE}^*$) provides direct control of the three-state outputs for bus control and fast access to data. The Chip Enable input ($\overline{CE}/\overline{CE}^*$) also controls the three-state outputs and, in addition, provides a "power down" feature to reduce chip current to less than 100µA. Since the access time to enable the ROM is the same as the address access time, no performance need be sacrificed to achieve reduced system power. The additional Chip Select ($\overline{CS1}/\overline{CS1}^*$) may be programmed to allow two 128K ROMs to be OR-tied without external decoding while still retaining the desirable functions of the Output Enable and Chip Enable inputs.

Designed to replace equivalent EPROMs and NMOS ROMs, the Solid State Scientific SCM23C128 is one of a family of state-of-the-art CMOS ROMs with densities of 32K, 64K, 128K and 256K bits with industry standard 24 and 28 lead pinouts.

Operating Characteristics Summary

Type	Operating Temperature Range	Address/Chip Enable Access Time	Output Enable Access Time
SCM23C128-1	0° to 70°C	100ns	50ns
SCM23C128-2	0° to 70°C	120ns	60ns
SCM23C128-3	-40° to +85°C	150ns	70ns
SCM23C128M	-55° to +125°C	150ns	70ns
883/23C128M	-55° to +125°C	150ns	70ns

Pin Configuration

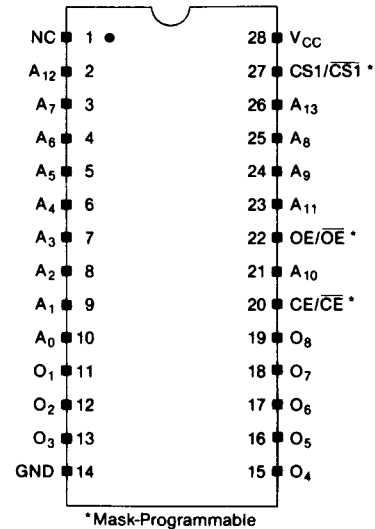

Block Diagram

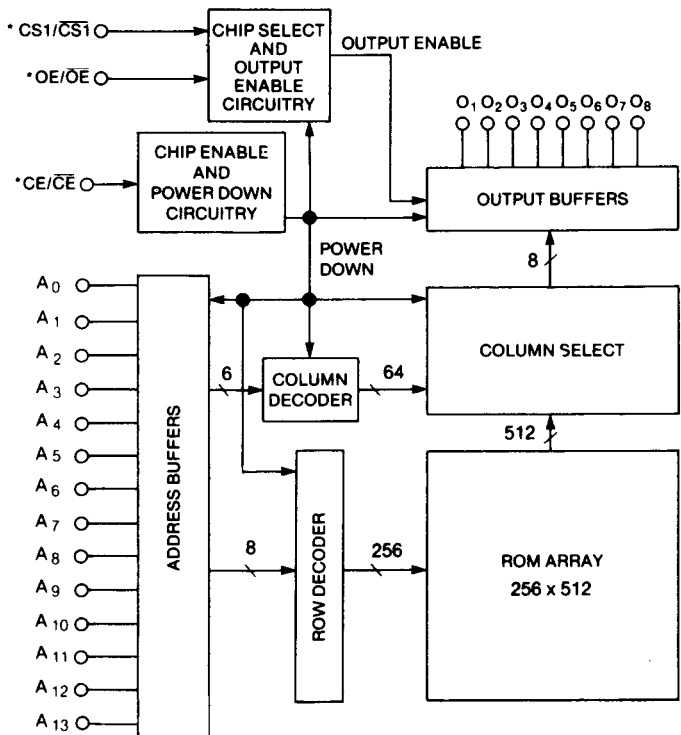

Absolute Maximum Limits

Storage Temperature	T_S	-65° to +150°C
DC Supply Voltage	V_{CC}	-0.5 to +7.0V
Input Voltage	V_{IN}	-0.3 ≤ V_{IN} ≤ $V_{CC} + 0.3$
Power Dissipation Per Package	P_T	500mW

Recommended Operating Conditions

Parameter	Limits	
DC Supply Voltage	V_{CC}	5V ± 10%
Operating Temperature (T_A)		
23C128-1/-2		0° to +70°C
23C128-3		-40° to +85°C
23C128M		-55° to +125°C

Timing Diagram

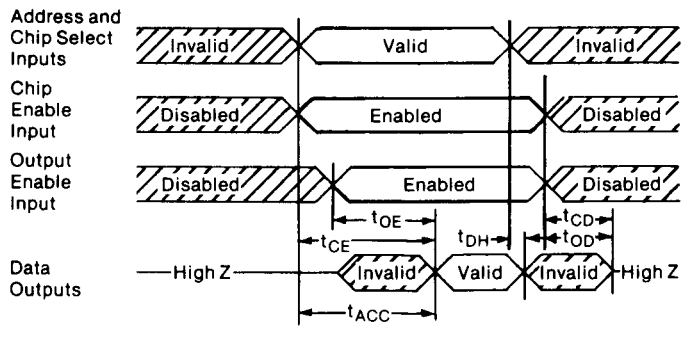

D.C. Characteristics ($V_{CC} = 5V \pm 10\%$)

Symbol	Parameter	Min.	Typ.(1)	Max.	Units	Conditions
V_{IH}	Input High Voltage	2.2			V	
V_{IL}	Input Low Voltage			0.8	V	
I_{LI}	Input Leakage Current			1.0	μA	$0V \leq V_{IN} \leq 5.5V$
V_{OH}	Output High Voltage	2.4			V	$I_{OH} = -1.0mA$
V_{OL}	Output Low Voltage			0.4	V	$I_{OL} = 3.2mA^{(4)}$
I_{LO}	Output Leakage Current			1.0	μA	Outputs Disabled
I_{CC}	Operating Current		7	25	mA	
I_{CCL1}	Standby Current		0.5	1	mA	Chip Disabled(2)
I_{CCL2}	Standby Current		20	100	μA	Chip Disabled(2)

A.C. Characteristics ($V_{CC} = 5V \pm 10\%$)

Symbol	Parameter	23C128-1 (0° to +70°C)		23C128-2 (0° to +70°C)		23C128-3 (-40° to +85°C)		23C128M (-55° to +125°C)		Units	Conditions
		Min.	Max.	Min.	Max.	Min.	Max.	Min.	Max.		
t_{ACC}	Access Time		100		120		150		150	ns	} Note 3
t_{CE}	Chip Enable Access Time		100		120		150		150	ns	
t_{CO}	Chip Disable to Output Float		30		30		30		30	ns	
t_{OE}	Output Enable Access Time		50		60		70		70	ns	
t_{OD}	Output Disable to Output Float		30		30		30		30	ns	
t_{DH}	Previous Data Valid After Address Change	5		5		5		5		ns	

- $T_A = 25^\circ C$; $V_{CC} = 5.0V$
- Two limits of standby current are applicable, the choice of which depends on the voltage level applied to the Chip Enable input (\overline{CE} or CE , as programmed):

Applicable Standby Current	\overline{CE} ($V_{IHmin.}$)	CE ($V_{ILmax.}$)
I_{CCL1}	2.0V	0.8V
I_{CCL2}	$V_{CC} - 0.4V$	0.4V

- A.C. TEST CONDITIONS
 - Input Pulse Levels: 0.8 to 2.4V
 - Input Rise/Fall Times: ≤ 10ns
 - Time Measurement Reference Level: 1.5V
 - Output Load: 1 TTL Load and $C_L = 100 pF$

4. The SCM23C128R version is available for RFI and noise sensitive applications. It meets all specifications for the 23C128 except I_{OL} ; which is specified at 1.6mA.