

TPS1110, TPS1110Y SINGLE P-CHANNEL LOGIC-LEVEL MOSFETS

SLVS100B – OCTOBER 1994 – REVISED JANUARY 1998

- Low $r_{DS(on)}$. . . 65 m Ω Typ at $V_{GS} = -4.5$ V
- High Current Capability
6 A at $V_{GS} = -4.5$ V
- Logic-Level Gate Drive (3 V Compatible)
 $V_{GS(th)} = -0.9$ V Max
- Low Drain-Source Leakage Current
<100 nA From 25°C to 75°C
at $V_{DS} = -6$ V
- Fast Switching . . . 5.8 ns Typ $t_{d(on)}$
- Small-Outline Surface-Mount Power Package

D PACKAGE
(TOP VIEW)

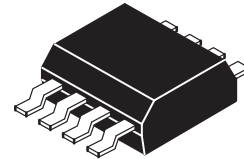
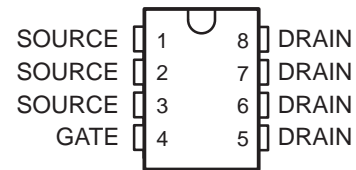

description

The TPS1110 is a single, low- $r_{DS(on)}$, P-channel enhancement-mode power MOS transistor. The device features extremely low- $r_{DS(on)}$ values coupled with logic-level gate-drive capability and very low drain-source leakage current. With a maximum $V_{GS(th)}$ of -0.9 V and an I_{DSS} of only -100 nA, the TPS1110 is the ideal high-side switch for low-voltage, portable battery-management power-distribution systems where maximizing battery life is an important concern. The thermal performance of the 8-pin small-outline (D) package has been greatly enhanced over the standard 8-pin SOIC, further making the TPS1110 ideally suited for many power applications. For compatibility with existing designs, the TPS1110 has a pinout common with other P-channel MOSFETs in small-outline integrated circuit (SOIC) packages. The TPS1110 is characterized for an operating junction temperature range, T_J , from -40°C to 150°C . The D package is available packaged in standard sleeves or in taped and reeled formats. When ordering the tape-and-reel format, add an R suffix to the device type number (e.g., TPS1110DR).

AVAILABLE OPTIONS

T_J	PACKAGED DEVICE†	CHIP FORM (Y)
	SMALL OUTLINE (D)	
-40°C to 150°C	TPS1110D	TPS1110Y

† The D package is available taped and reeled. Add an R suffix to device type (e.g., TPS1110DR). The chip form is tested at 25°C .

schematic

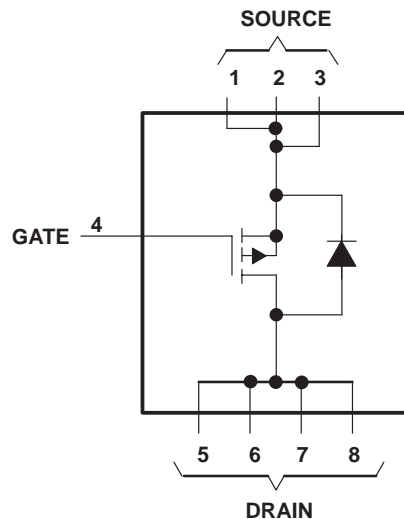

PRODUCTION DATA information is current as of publication date. Products conform to specifications per the terms of Texas Instruments standard warranty. Production processing does not necessarily include testing of all parameters.

 **TEXAS
INSTRUMENTS**

POST OFFICE BOX 655303 • DALLAS, TEXAS 75265

Copyright © 1998, Texas Instruments Incorporated

TPS1110, TPS1110Y SINGLE P-CHANNEL LOGIC-LEVEL MOSFETS

SLVS100B – OCTOBER 1994 – REVISED JANUARY 1998

TPS1110Y chip information

This chip, when properly assembled, displays characteristics similar to the TPS1110C. Thermal compression or ultrasonic bonding may be used on the doped aluminum bonding pads. The chip may be mounted with conductive epoxy or a gold-silicon preform.

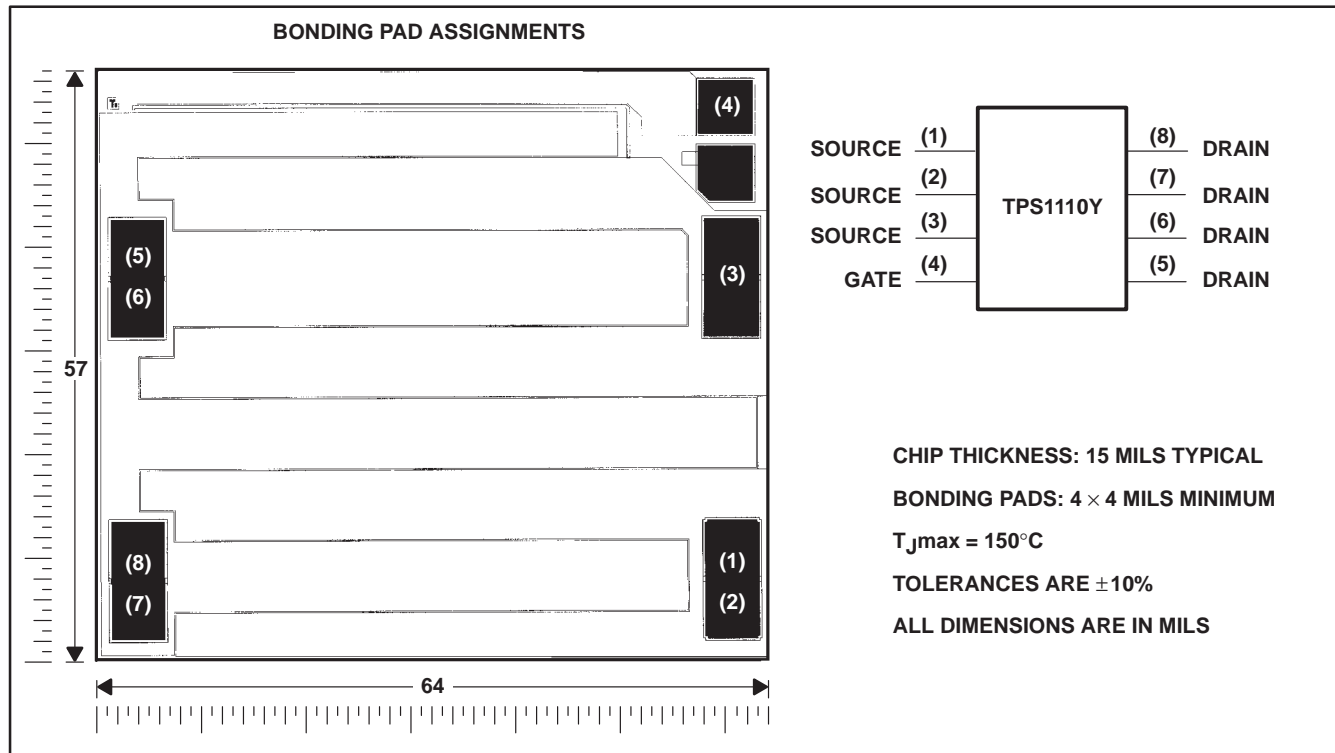

TPS1110, TPS1110Y SINGLE P-CHANNEL LOGIC-LEVEL MOSFETS

SLVS100B – OCTOBER 1994 – REVISED JANUARY 1998

absolute maximum ratings over operating free-air temperature (unless otherwise noted)†

				UNIT
Drain-to-source voltage, V_{DS}			-7	V
Gate-to-source voltage, V_{GS}			±7	V
Continuous drain current, I_D	$V_{GS} = -2.7$ V	$T_P = 25^\circ\text{C}^\ddagger$	-5	A
		$T_P = 125^\circ\text{C}^\ddagger$	-2.3	
	$V_{GS} = -4.5$ V	$T_P = 25^\circ\text{C}^\ddagger$	-6	
		$T_P = 125^\circ\text{C}^\ddagger$	-2.7	
Pulse drain current, I_D		$T_A = 25^\circ\text{C}$	-24	A
Continuous source current (diode conduction), I_S		$T_A = 25^\circ\text{C}$	-6	A
Continuous total power dissipation		$T_P = 25^\circ\text{C}^\ddagger$	4	W
Junction-to-pin thermal resistance (θ_{JP})			31	$^\circ\text{C}/\text{W}$
Continuous total power dissipation		$T_A = 25^\circ\text{C}$	1.25	W
Junction-to-ambient thermal resistance (θ_{JA})			100	$^\circ\text{C}/\text{W}$
Storage temperature range, T_{stg}			-65 to 150	$^\circ\text{C}$
Operating junction temperature range, T_J			-40 to 150	$^\circ\text{C}$
Lead temperature 1,6 mm (1/16 inch) from case for 10 seconds			260	$^\circ\text{C}$

† Stresses beyond those listed under “absolute maximum ratings” may cause permanent damage to the device. These are stress ratings only, and functional operation of the device at these or any other conditions beyond those indicated under “recommended operating conditions” is not implied. Exposure to absolute-maximum-rated conditions for extended periods may affect device reliability.

‡ T_P – Temperature of drain pins measured close to the package

electrical characteristics at $T_J = 25^\circ\text{C}$ (unless otherwise noted)

static

PARAMETER	TEST CONDITIONS	TPS1110			TPS1110Y			UNIT
		MIN	TYP	MAX	MIN	TYP	MAX	
$V_{GS(th)}$ Gate-to-source threshold voltage	$V_{DS} = V_{GS}$, See Figure 9 $I_D = -250 \mu\text{A}$,	-0.5	-0.75	-0.9	-0.75			V
V_{SD} Source-to-drain voltage (diode forward voltage)§	$I_{SD} = -3$ A, See Figure 8 $V_{GS} = 0$ V,	-0.8			-0.8			V
I_{GSS} Reverse gate current, drain short circuited to source	$V_{DS} = 0$ V, $V_{GS} = -6$ V	±100						nA
I_{DSS} Zero-gate-voltage drain current	$V_{DS} = -7$ V, $V_{GS} = 0$ V $T_J = 25^\circ\text{C}$	-100						nA
	$V_{DS} = -6$ V, $V_{GS} = 0$ V $T_J = 75^\circ\text{C}$	-100						nA
	$V_{DS} = -6$ V, $V_{GS} = 0$ V $T_J = 125^\circ\text{C}$	-10						μA
$r_{DS(on)}$ Static drain-to-source on-state resistance§	$V_{GS} = -4.5$ V, See Figure 5 $I_D = -6$ A,	65	75		65			m Ω
	$V_{GS} = -2.7$ V, See Figure 5 $I_D = -2$ A,	100	110		100			
g_{fs} Forward transconductance§	$V_{DS} = -5$ V, $I_D = -6$ A	5			5			S
C_{iss} Short-circuit input capacitance, common source	$V_{DS} = -6$ V, $f = 1$ MHz $V_{GS} = 0$ V, See Figure 6	275			275			pF
C_{oss} Short-circuit output capacitance, common source		415			415			
C_{rss} Short-circuit reverse transfer capacitance, common source		73			73			

§ Pulse test: pulse duration $\leq 300 \mu\text{s}$, duty cycle $\leq 2\%$



TPS1110, TPS1110Y SINGLE P-CHANNEL LOGIC-LEVEL MOSFETS

SLVS100B – OCTOBER 1994 – REVISED JANUARY 1998

dynamic

PARAMETER	TEST CONDITIONS	TPS1110			TPS1110Y			UNIT
		MIN	TYP	MAX	MIN	TYP	MAX	
Q_g Total gate charge	$V_{DS} = -6\text{ V}$, $V_{GS} = -6\text{ V}$, See Figures 1 and 10	4.3	5.4		4.3			nC
Q_{gs} Gate-to-source charge		0.66	0.83		0.66			
Q_{gd} Gate-to-drain charge		0.52	0.68		0.52			
$t_{d(on)}$ Turn-on delay time	$V_{DD} = -6\text{ V}$, $R_L = 6\ \Omega$, $R_G = 6\ \Omega$, See Figure 2	5.8	8		5.8			ns
$t_{d(off)}$ Turn-off delay time		22	29		22			ns
t_r Rise time		22	29		22			ns
t_f Fall time		4.5	7		4.5			
$t_{rr(SD)}$ Source-to-drain reverse-recovery time	$V_{DS} = -6\text{ V}$, $di/dt = 100\text{ A}/\mu\text{s}$, $I_D = -3\text{ A}$	65	98		65			ns
Q_{rr} Total diode charge		71			71			

PARAMETER MEASUREMENT INFORMATION

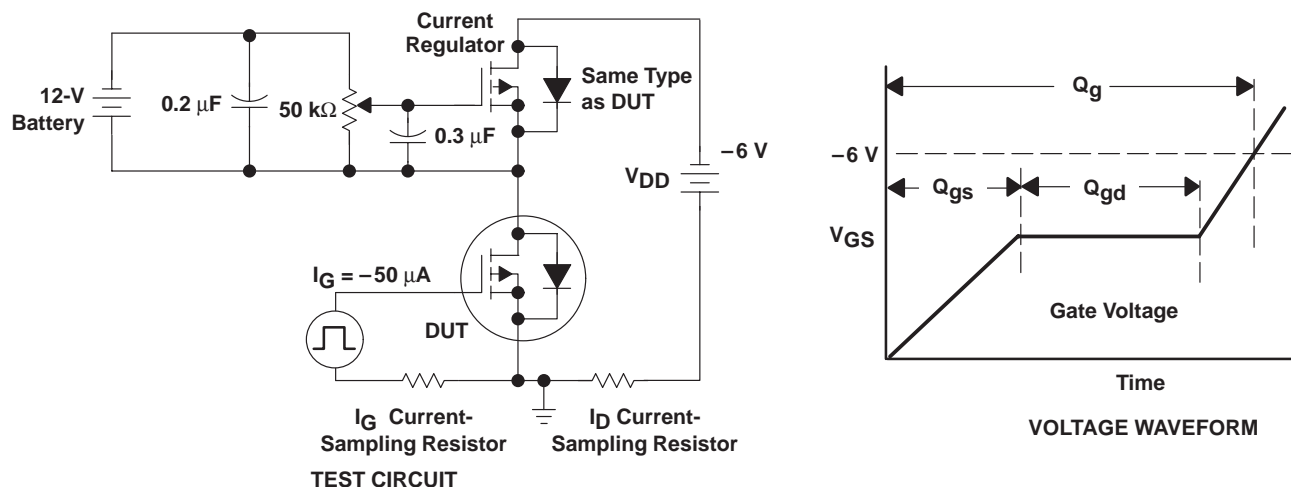

Figure 1. Gate-Charge Test Circuit and Waveform

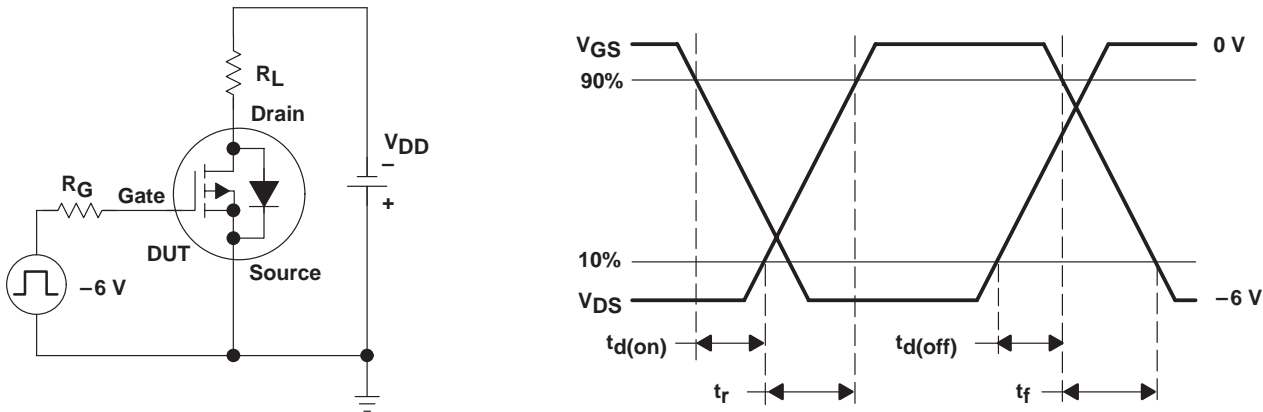

Figure 2. Resistive Switching

TPS1110, TPS1110Y SINGLE P-CHANNEL LOGIC-LEVEL MOSFETS

SLVS100B – OCTOBER 1994 – REVISED JANUARY 1998

TYPICAL CHARACTERISTICS

Table of Graphs

		FIGURE
Drain current	vs Drain-to-source voltage	3
Drain current	vs Gate-to-source voltage	4
Static drain-to-source on-state resistance	vs Drain current	5
Capacitance	vs Drain-to-source voltage	6
Static drain-to-source on-state resistance (normalized)	vs Junction temperature	7
Source-to-drain diode current	vs Source-to-drain voltage	8
Gate-to-source threshold voltage	vs Junction temperature	9
Gate-to-source voltage	vs Gate charge	10

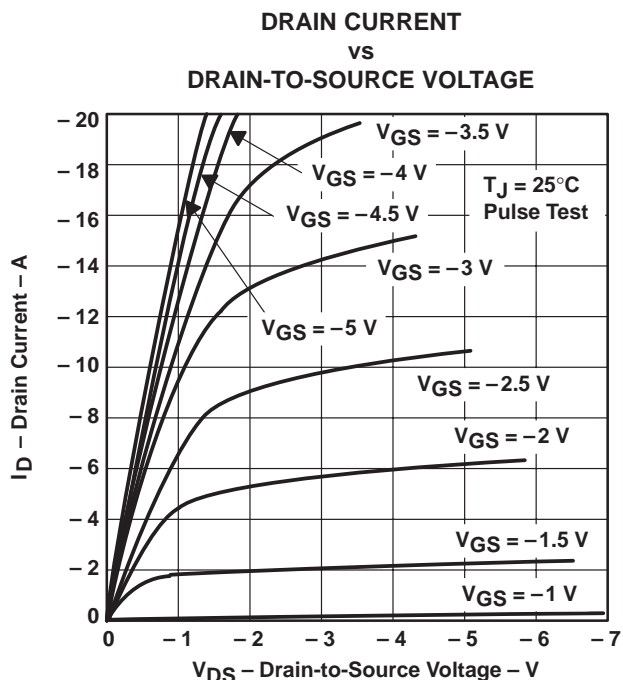

Figure 3

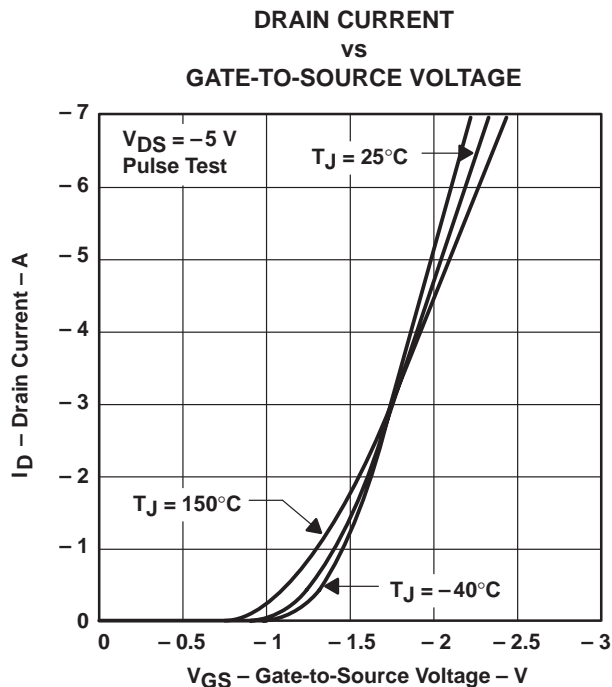

Figure 4

TYPICAL CHARACTERISTICS

STATIC DRAIN-TO-SOURCE ON-STATE RESISTANCE
vs
DRAIN CURRENT

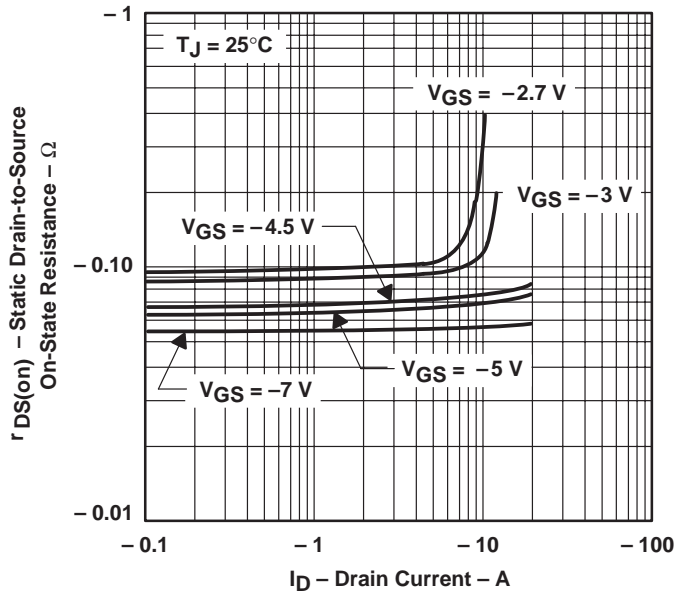
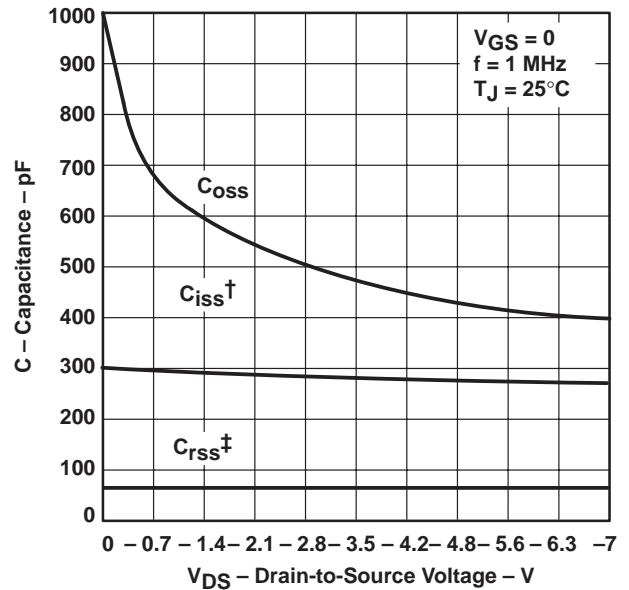

Figure 5

CAPACITANCE†
vs
DRAIN-TO-SOURCE VOLTAGE



† $C_{iss} = C_{gs} + C_{gd}$, $C_{ds(\text{shorted})}$
 ‡ $C_{rss} = C_{gd}$, $C_{oss} = C_{ds} + C_{gd}$

Figure 6

STATIC DRAIN-TO-SOURCE
ON-STATE RESISTANCE (NORMALIZED)
vs
JUNCTION TEMPERATURE

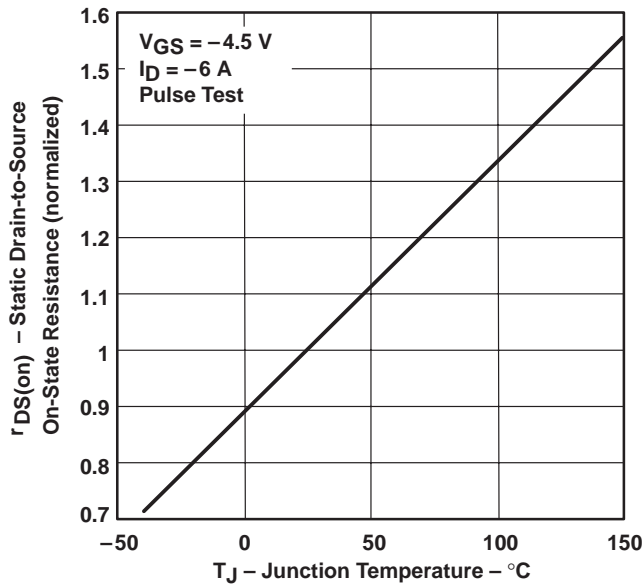

Figure 7

SOURCE-TO-DRAIN DIODE CURRENT
vs
SOURCE-TO-DRAIN VOLTAGE

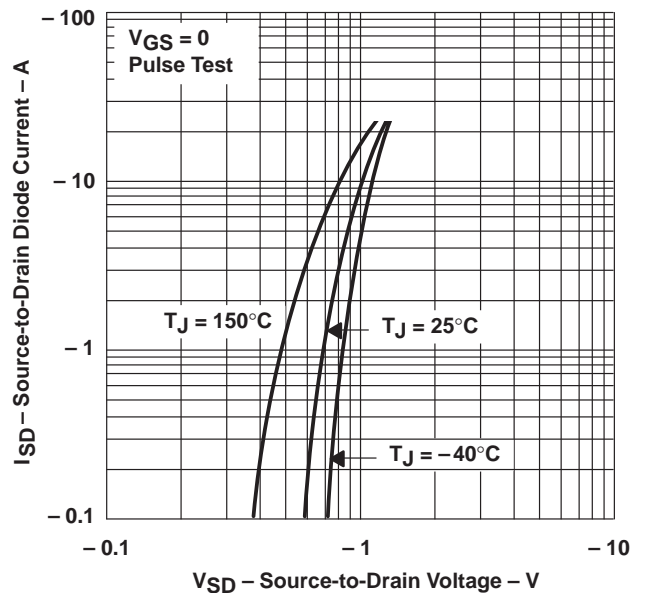

Figure 8

TPS1110, TPS1110Y SINGLE P-CHANNEL LOGIC-LEVEL MOSFETS

SLVS100B – OCTOBER 1994 – REVISED JANUARY 1998

TYPICAL CHARACTERISTICS

GATE-TO-SOURCE THRESHOLD VOLTAGE
vs
JUNCTION TEMPERATURE

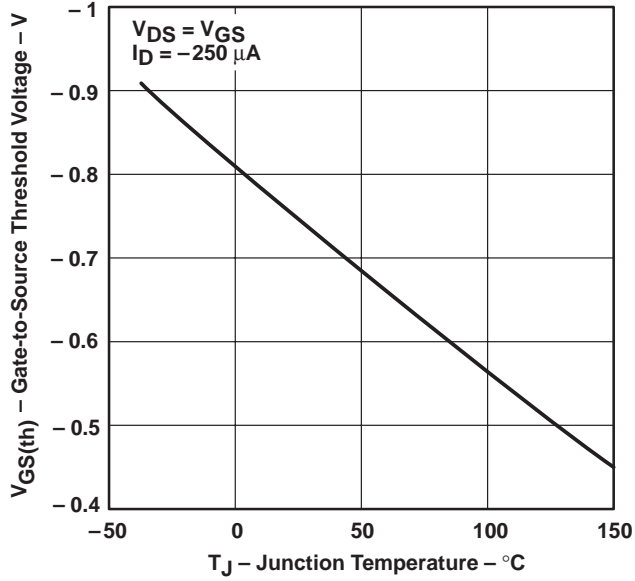

Figure 9

GATE-TO-SOURCE VOLTAGE
vs
GATE CHARGE

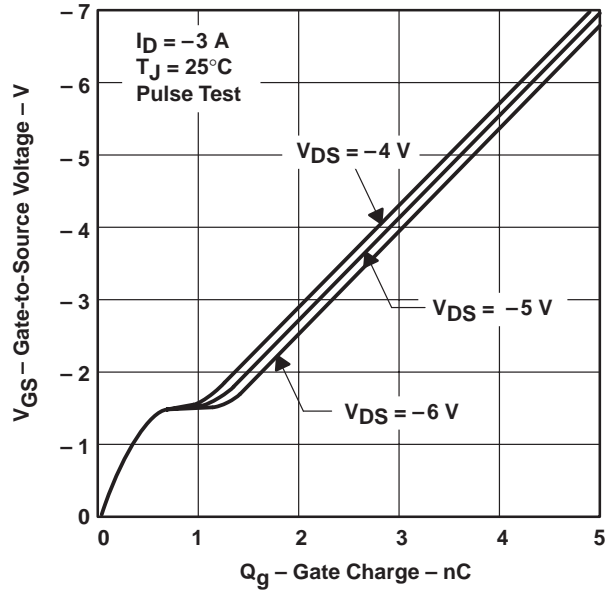

Figure 10

THERMAL INFORMATION

Table of Graphs

		FIGURE
Maximum drain current	vs Drain-to-source voltage	11
Junction-to-pin thermal resistance (normalized)	vs Pulse duration	12
Junction-to-ambient thermal resistance (normalized)	vs Pulse duration	13

MAXIMUM DRAIN CURRENT
vs
DRAIN-TO-SOURCE VOLTAGE

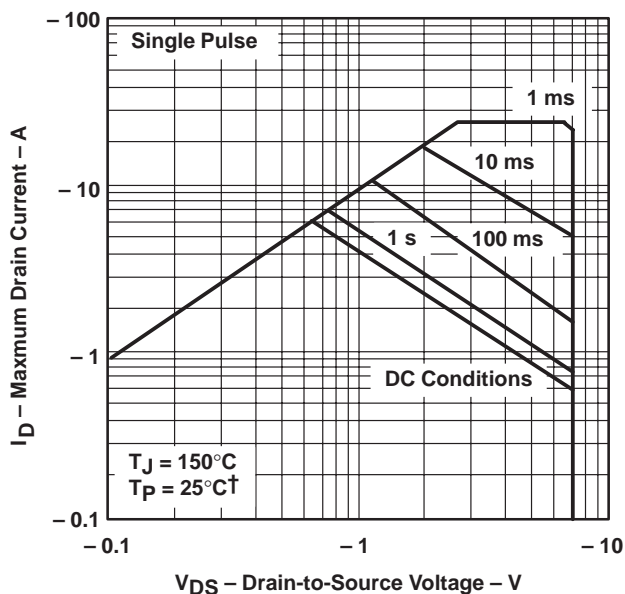

$^\dagger T_P$ – Temperature of drain pins measured close to the package

Figure 11

TPS1110, TPS1110Y SINGLE P-CHANNEL LOGIC-LEVEL MOSFETS

SLVS100B – OCTOBER 1994 – REVISED JANUARY 1998

THERMAL INFORMATION

JUNCTION-TO-PIN THERMAL RESISTANCE (NORMALIZED) vs PULSE DURATION

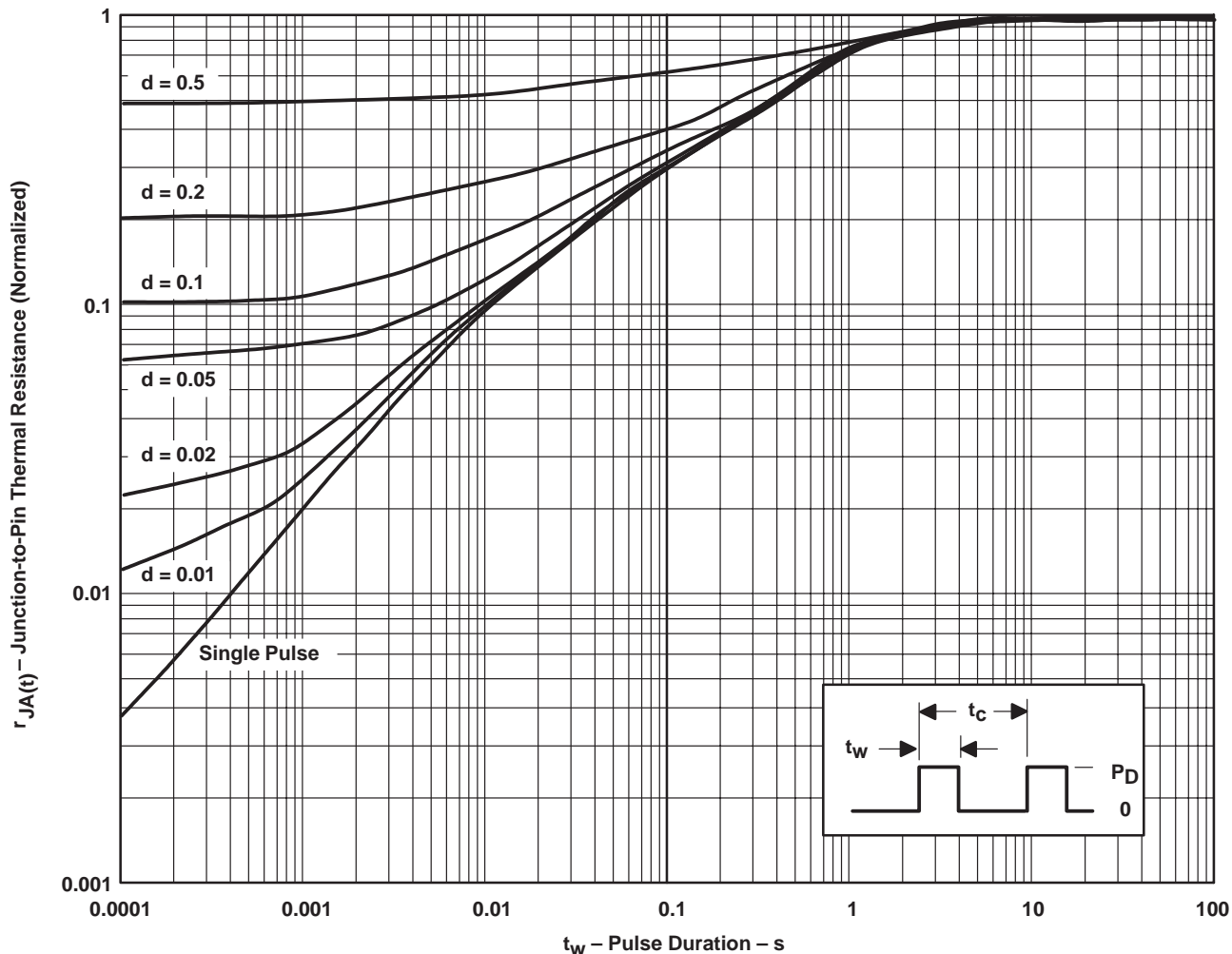

NOTE A: $Z_{\theta JP}(t) = r_{JP}(t) \cdot \theta_{JP}$
 t_w = pulse duration
 t_c = cycle time
 d = duty cycle = t_w/t_c
 peak $T_J = P_D \cdot Z_{\theta JP}(t) + T_P$

Figure 12



POST OFFICE BOX 655303 • DALLAS, TEXAS 75265

THERMAL INFORMATION

JUNCTION-TO-AMBIENT THERMAL RESISTANCE (NORMALIZED)[†]
vs
PULSE DURATION

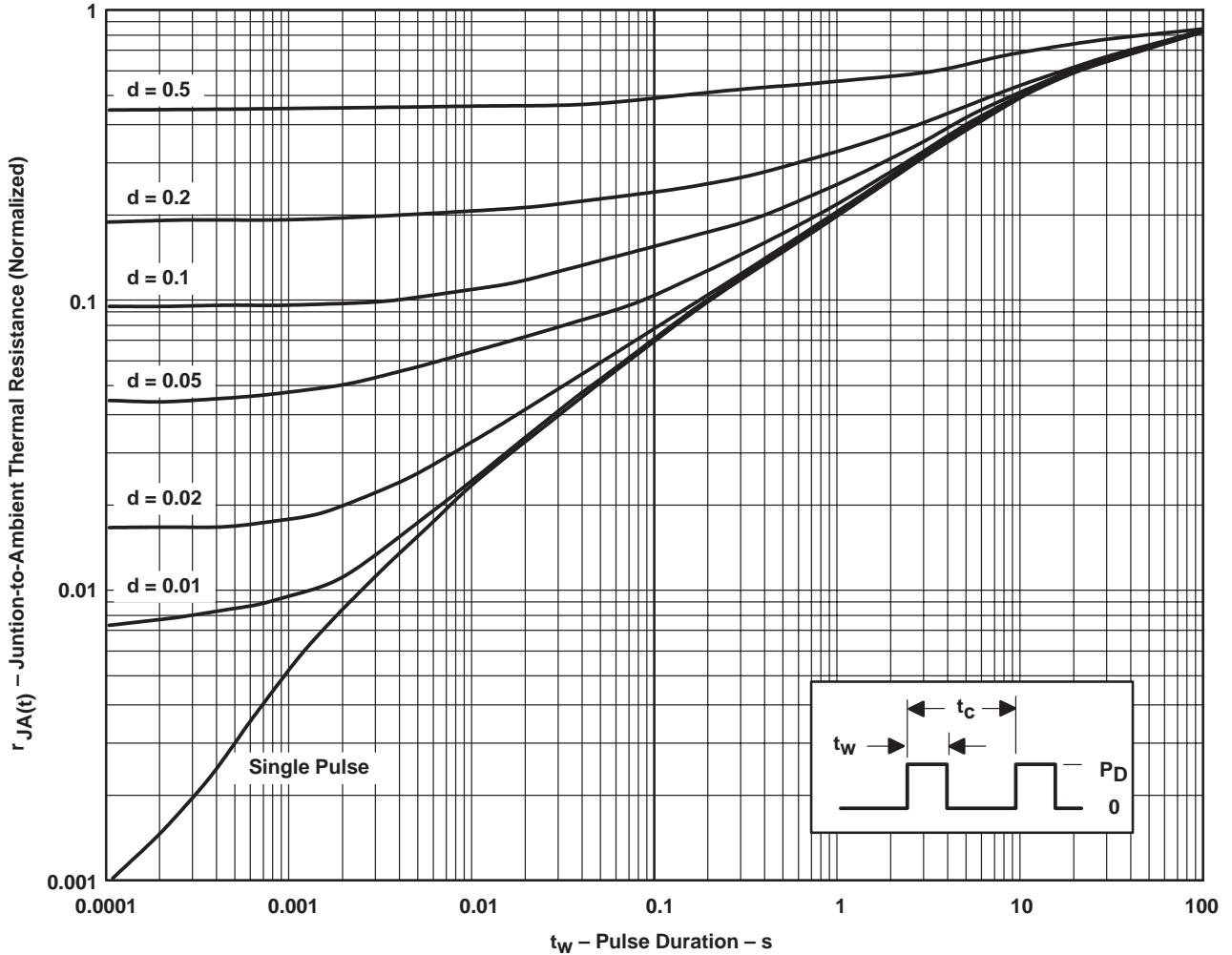

[†] Device mounted on FR4 printed-circuit board with no special thermal considerations.

NOTE A: $Z_{\theta JA}(t) = r_{JA}(t) \cdot \theta_{JA}$
 t_w = pulse duration
 t_c = cycle time
 d = duty cycle = t_w/t_c
 peak $T_J = P_D \cdot Z_{\theta JA}(t) + T_A$

Figure 13

TPS1110, TPS1110Y SINGLE P-CHANNEL LOGIC-LEVEL MOSFETS

SLVS100B – OCTOBER 1994 – REVISED JANUARY 1998

MECHANICAL INFORMATION

D (R-PDSO-G**)

PLASTIC SMALL-OUTLINE PACKAGE

14 PIN SHOWN

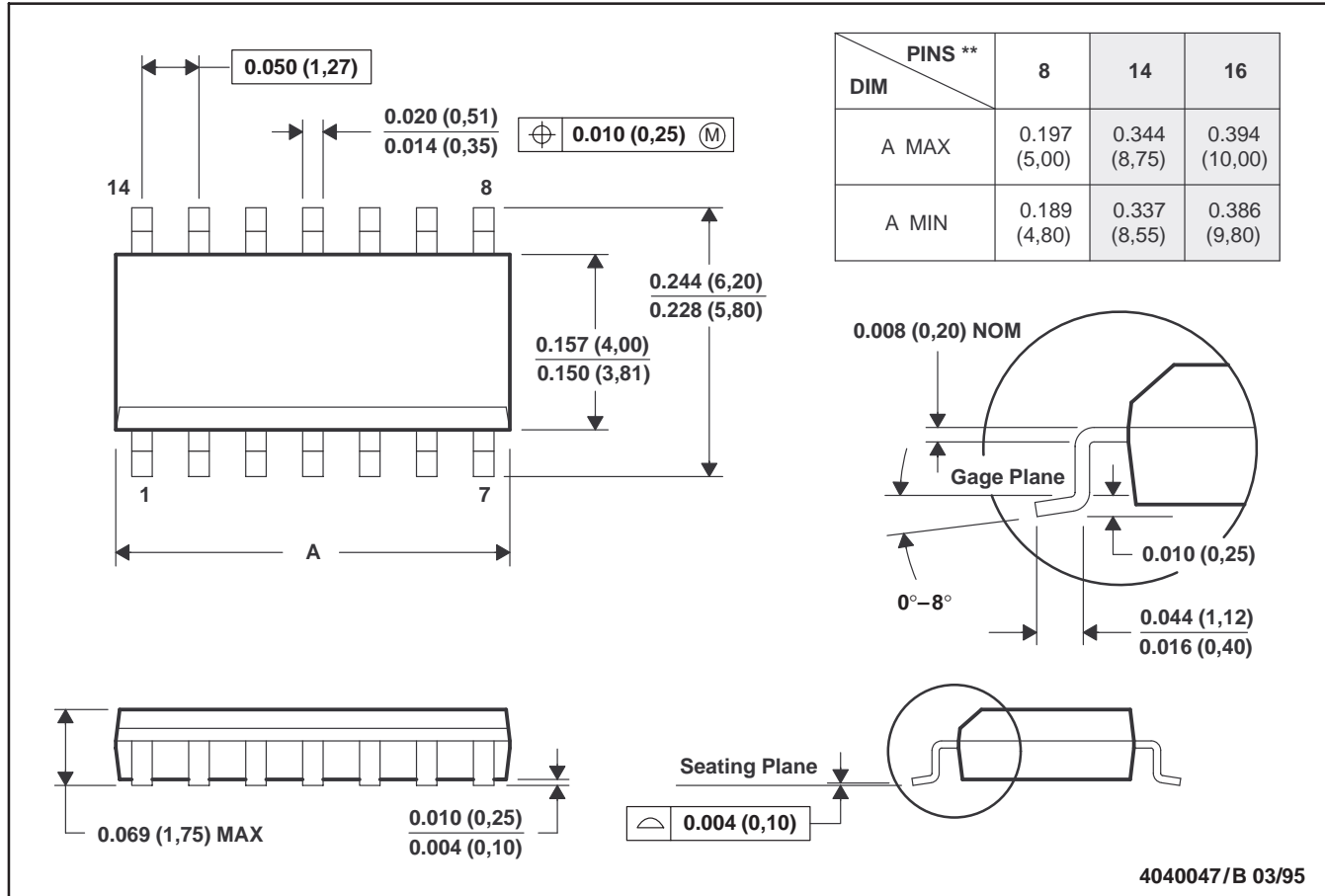

4040047/B 03/95

- NOTES:
- All linear dimensions are in inches (millimeters).
 - This drawing is subject to change without notice.
 - Body dimensions do not include mold flash or protrusion, not to exceed 0.006 (0,15).
 - Four center pins are connected to die mount pad.
 - Falls within JEDEC MS-012

PACKAGING INFORMATION

Orderable Device	Status ⁽¹⁾	Package Type	Package Drawing	Pins	Package Qty	Eco Plan ⁽²⁾	Lead/Ball Finish	MSL Peak Temp ⁽³⁾
TPS1110D	OBSOLETE	SOIC	D	8		TBD	Call TI	Call TI
TPS1110DR	OBSOLETE	SOIC	D	8		TBD	Call TI	Call TI

⁽¹⁾ The marketing status values are defined as follows:

ACTIVE: Product device recommended for new designs.

LIFEBUY: TI has announced that the device will be discontinued, and a lifetime-buy period is in effect.

NRND: Not recommended for new designs. Device is in production to support existing customers, but TI does not recommend using this part in a new design.

PREVIEW: Device has been announced but is not in production. Samples may or may not be available.

OBSOLETE: TI has discontinued the production of the device.

⁽²⁾ Eco Plan - The planned eco-friendly classification: Pb-Free (RoHS) or Green (RoHS & no Sb/Br) - please check <http://www.ti.com/productcontent> for the latest availability information and additional product content details.

TBD: The Pb-Free/Green conversion plan has not been defined.

Pb-Free (RoHS): TI's terms "Lead-Free" or "Pb-Free" mean semiconductor products that are compatible with the current RoHS requirements for all 6 substances, including the requirement that lead not exceed 0.1% by weight in homogeneous materials. Where designed to be soldered at high temperatures, TI Pb-Free products are suitable for use in specified lead-free processes.

Green (RoHS & no Sb/Br): TI defines "Green" to mean Pb-Free (RoHS compatible), and free of Bromine (Br) and Antimony (Sb) based flame retardants (Br or Sb do not exceed 0.1% by weight in homogeneous material)

⁽³⁾ MSL, Peak Temp. -- The Moisture Sensitivity Level rating according to the JEDEC industry standard classifications, and peak solder temperature.

Important Information and Disclaimer:The information provided on this page represents TI's knowledge and belief as of the date that it is provided. TI bases its knowledge and belief on information provided by third parties, and makes no representation or warranty as to the accuracy of such information. Efforts are underway to better integrate information from third parties. TI has taken and continues to take reasonable steps to provide representative and accurate information but may not have conducted destructive testing or chemical analysis on incoming materials and chemicals. TI and TI suppliers consider certain information to be proprietary, and thus CAS numbers and other limited information may not be available for release.

In no event shall TI's liability arising out of such information exceed the total purchase price of the TI part(s) at issue in this document sold by TI to Customer on an annual basis.

IMPORTANT NOTICE

Texas Instruments Incorporated and its subsidiaries (TI) reserve the right to make corrections, modifications, enhancements, improvements, and other changes to its products and services at any time and to discontinue any product or service without notice. Customers should obtain the latest relevant information before placing orders and should verify that such information is current and complete. All products are sold subject to TI's terms and conditions of sale supplied at the time of order acknowledgment.

TI warrants performance of its hardware products to the specifications applicable at the time of sale in accordance with TI's standard warranty. Testing and other quality control techniques are used to the extent TI deems necessary to support this warranty. Except where mandated by government requirements, testing of all parameters of each product is not necessarily performed.

TI assumes no liability for applications assistance or customer product design. Customers are responsible for their products and applications using TI components. To minimize the risks associated with customer products and applications, customers should provide adequate design and operating safeguards.

TI does not warrant or represent that any license, either express or implied, is granted under any TI patent right, copyright, mask work right, or other TI intellectual property right relating to any combination, machine, or process in which TI products or services are used. Information published by TI regarding third-party products or services does not constitute a license from TI to use such products or services or a warranty or endorsement thereof. Use of such information may require a license from a third party under the patents or other intellectual property of the third party, or a license from TI under the patents or other intellectual property of TI.

Reproduction of information in TI data books or data sheets is permissible only if reproduction is without alteration and is accompanied by all associated warranties, conditions, limitations, and notices. Reproduction of this information with alteration is an unfair and deceptive business practice. TI is not responsible or liable for such altered documentation.

Resale of TI products or services with statements different from or beyond the parameters stated by TI for that product or service voids all express and any implied warranties for the associated TI product or service and is an unfair and deceptive business practice. TI is not responsible or liable for any such statements.

Following are URLs where you can obtain information on other Texas Instruments products and application solutions:

Products		Applications	
Amplifiers	amplifier.ti.com	Audio	www.ti.com/audio
Data Converters	dataconverter.ti.com	Automotive	www.ti.com/automotive
DSP	dsp.ti.com	Broadband	www.ti.com/broadband
Interface	interface.ti.com	Digital Control	www.ti.com/digitalcontrol
Logic	logic.ti.com	Military	www.ti.com/military
Power Mgmt	power.ti.com	Optical Networking	www.ti.com/opticalnetwork
Microcontrollers	microcontroller.ti.com	Security	www.ti.com/security
		Telephony	www.ti.com/telephony
		Video & Imaging	www.ti.com/video
		Wireless	www.ti.com/wireless

Mailing Address: Texas Instruments
Post Office Box 655303 Dallas, Texas 75265