

Push-on Lock Coaxial Connectors for Digital Broadcasting Applications

PL71 Series

75Ω Up to 3 GHz

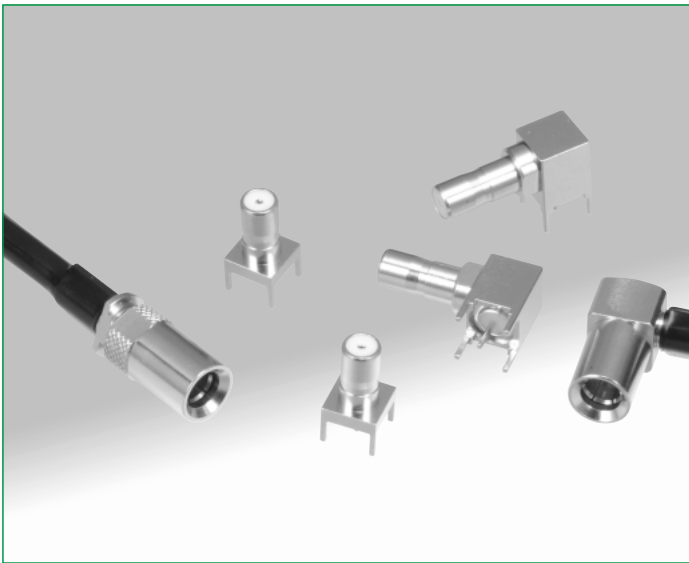

■ Features

1. 20% downsized compared with conventional 75 ohm BNC connectors.

2. Superior locking mechanism

Our exclusive locking method keeps the mating part in constant contact with the electric reference plane (Top Touch), ensuring high contact stability and reliability. The construction is protected by the outer shell.

3. Stable, stationary center contact structure

The stationary design protects the extremely thin center conductor of this 75 ohm coaxial cable from potential damage. Damage can be caused by rotational forces during mating and unmating.

4. Reliable at high frequencies

The high-frequency performance of the PL71 Series is very reliable, with V.S.W.R. characteristics of a maximum of 1.3 at DC, and up to 3 GHz, which is suitable for 3G-SDI broadcasting equipment.

■ Applications

The PL71 Series is well suited for use in the digital cable television broadcasting industry. This 75 ohm coaxial series can work together with BNC(75)Series and PO82M Series to configure a wide range of functions, including interface connections, plug-in mounting, and wiring within devices.

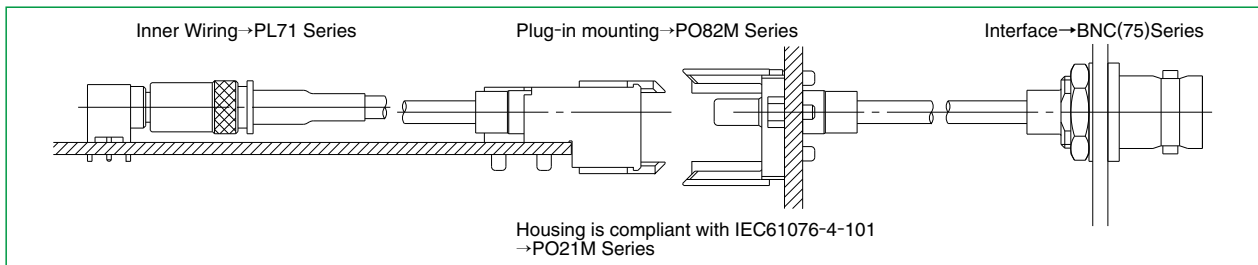

■ Mating Chart

Plugs
<p>■ Straight PL71-P-***</p>
<p>■ Right-angle PL71-LP-***</p>

Receptacles
<p>■ Straight PL71-R-PC</p>
<p>■ Right-angle PL71-LR-PC</p>

In cases where the application will demand a high level of reliability, such as automotive, please contact a company representative for further information.

Specifications

Ratings	Nominal characteristic impedance : 75Ω Frequency range : DC to 3 GHz	Operating temperature range : -30°C to +85°C Operating humidity : RH 95% max.
Item	Specification	Conditions
1. Contact resistance	6 mΩ max.	100 mA max.
2. Insulation resistance	1,000 MΩ min.	500 V DC
3. Withstanding voltage	No flashover of insulation breakdown	500 V AC / 1 minute
4. V.S.W.R.	1.3max.	DC to 3 GHz
5. Center contact	0.5N min.	Measured with 0.49mm diameter pin gauge
6. Insertion and withdrawal forces	9.8 N min.	Measured with the applicable mating pair
7. Durability(mating/unmating with corresponding plug)	Contact resistance 6 mΩ max.	500 mating cycles
8. Vibration	No electrical discontinuity of 1μs or longer No damage, cracks, or parts dislocation	Frequency: 10 to 500 Hz, single amplitude of 0.75 mm, acceleration of 98m/s ² , 10 cycles in each of the 3 axial directions
9. Shock resistance	No electrical discontinuity of 1μs or longer No damage, cracks, or parts dislocation	Acceleration of 490m/s ² , for a duration of 11 ms, sine half-wave waveform, 3cycles in each of the 3 axial directions
10. Moisture resistance	Insulation resistance: 100 MΩ min. (high humidity) Insulation resistance: 1,000 MΩ min. (dry) No damage, cracks, or parts dislocation	240 hours at +25°C to +65°C and humidity of 80% to 96%
11. Temperature cycle	No damage, crack, or part dislocation	Temperature: -55°C → +5°C to +35°C → +85°C → +5°C to +35°C Time: 30 min. → 5 min.max. → 30 min. → 5 min.max. 5 cycles
12. Salt spray	No corrosion	5% salt water solution, 48 hours

Note: Some products may have different specifications from those shown above. Please confirm requirements before ordering.

Materials

Part	Materials	Finish	Remarks
Shell	Brass	Nickel plated	—
Male center contact	Brass	Gold plated	—
Female center contact	Beryllium copper	Gold plated	—
Insulator	PTFE	—	Flame retardant

① Series name	: PL71
② Connector type	
P	: Straight plug
LP	: Right-angle plug
R	: Straight receptacle
LR	: Right-angle receptacle
③ Applicable cable(plug) or board	
1.5C	: 1.5C-QEV.CW
1.5CW	: 1.5C-QEW.CW
PC	: DIP mounting

Ordering information

PL71 - [1] - [2]

① ② ③

■ Plugs

● Straight

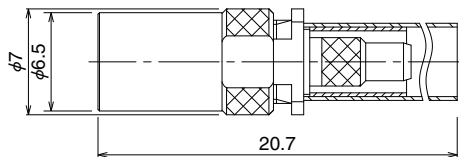

All dimensions:mm

Part No.	HRS No.	Applicable cable	RoHS
PL71-P-1.5CW(40)	334-0001-5 40	1.5C-QEW.CW	Yes
PL71-P-1.5CV-1(40)	334-0069-9 40	1.5C-QEV.CW	

● Right angle

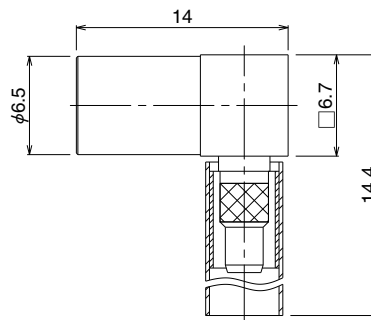
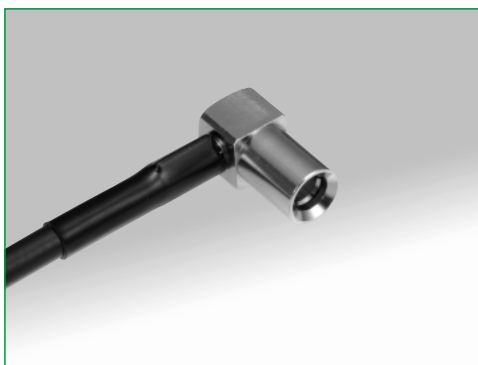

All dimensions:mm

Part No.	HRS No.	Applicable cable	RoHS
PL71-LP-1.5CW(40)	334-0006-9 40	1.5C-QEW.CW	Yes
PL71-LP-1.5C(40)	334-0007-1 40	1.5C-QEV.CW	

■ Receptacles

● Straight



● PCB mounting pattern

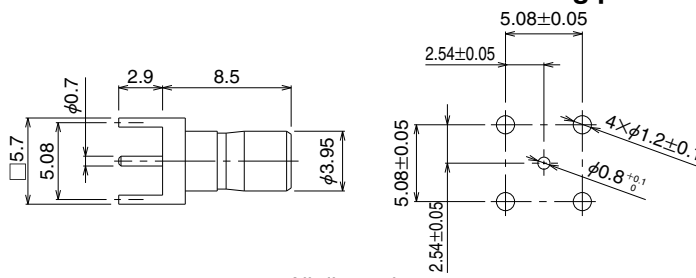

All dimensions:mm

Part No.	HRS No.	RoHS
PL71-R-PC(40)	334-0011-9 40	Yes

● Right angle

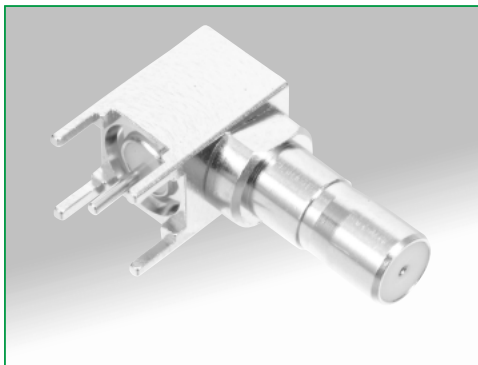

● PCB mounting pattern

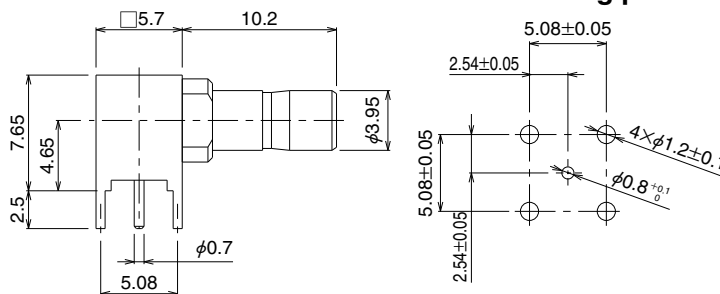

All dimensions:mm

Part No.	HRS No.	RoHS
PL71-LR-PC(40)	334-0016-2 40	Yes

◆ High Frequency Characteristics of 75Ω Hirose product series

● BNC(75) Series

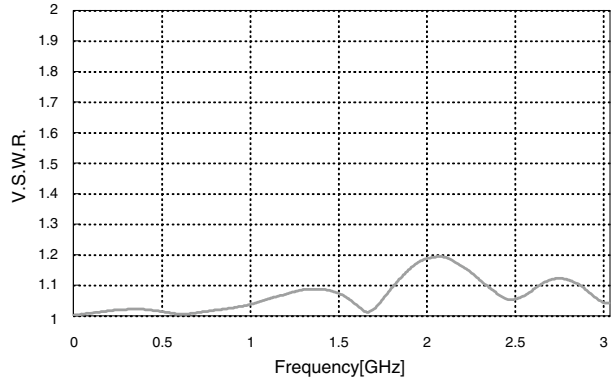
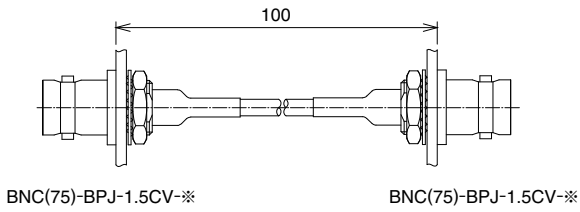

● PL71 Series

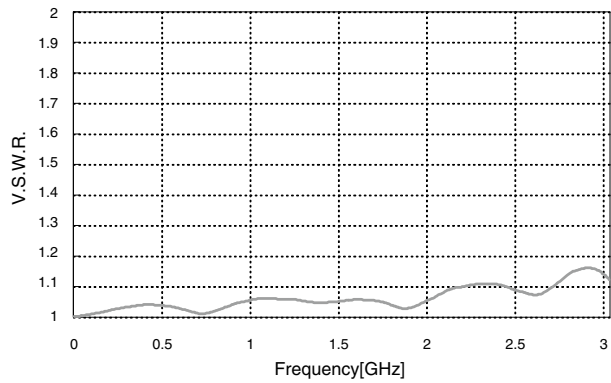
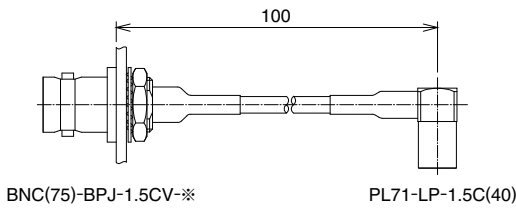

● PL75 Series

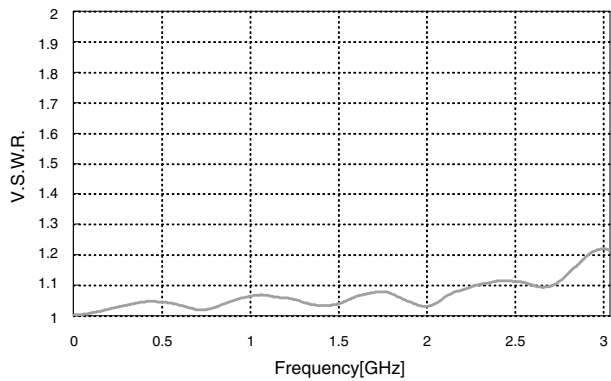
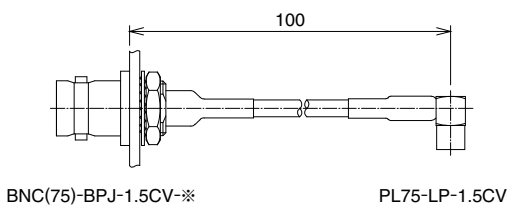

● H.FL75 Series

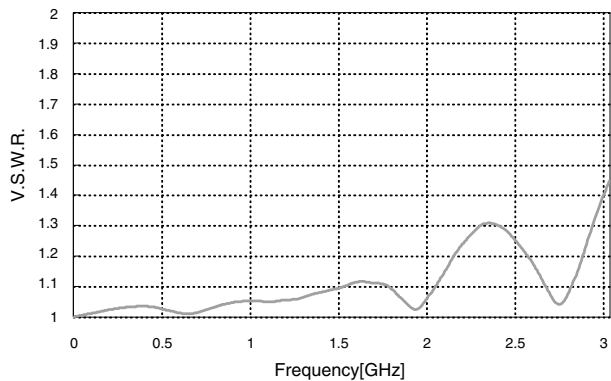
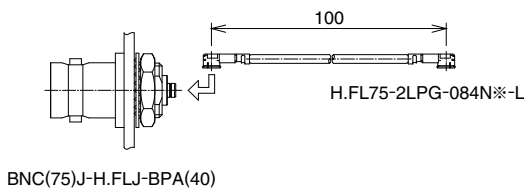

HIROSE ELECTRIC CO.,LTD.

2-6-3,Nakagawa Chuoh,Tsuzuki-Ku,Yokohama-Shi 224-8540,JAPAN

TEL: +81-45-620-3526 Fax: +81-45-591-3726

<http://www.hirose.com>

<http://www.hirose-connectors.com>