

D10040200PH1

GaAs/GaN Power Doubler Hybrid
45MHz to 1000MHz

The D10040200PH1 is a Hybrid Power Doubler amplifier module. The part employs GaAs pHEMT and GaN HEMT die and is operated from 45MHz to 1000MHz. It provides high output capability, excellent linearity, and superior return loss performance with low noise and optimal reliability.

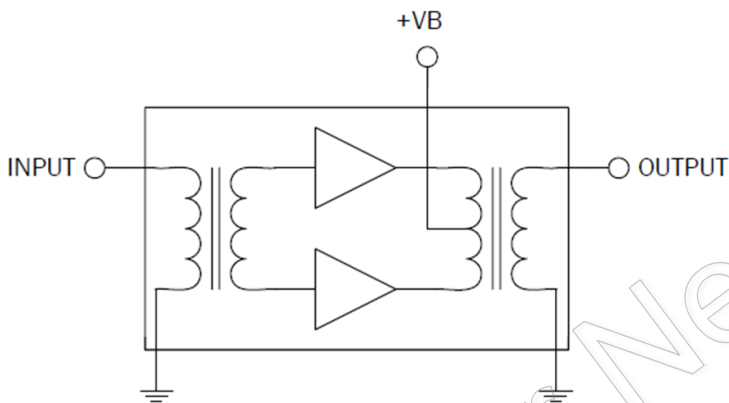

Package: SOT-115J

Features

- Low Current
- Excellent Linearity
- Superior Return Loss Performance
- Extremely Low Distortion
- Optimal Reliability
- Extremely Low Noise
- Unconditionally Stable Under All Terminations
- High Output Capacity
- 20.0dB Min. Gain at 1GHz
- 450mA Max. at 24VDC

Applications

- 45MHz to 1000MHz CATV Amplifier Systems

Ordering Information

D10040200PH1 Box with 50 pieces

Absolute Maximum Ratings

Parameter	Rating	Unit
RF Input Voltage (single tone)	65	dBmV
DC Supply Over-Voltage (5 minutes)	30	V
Storage Temperature	-40 to +100	°C
Operating Mounting Base Temperature	-30 to +100	°C



Caution! ESD sensitive device.



RoHS (Restriction of Hazardous Substances): Compliant per EU Directive 2011/65/EU.

Exceeding any one or a combination of the Absolute Maximum Rating conditions may cause permanent damage to the device. Extended application of Absolute Maximum Rating conditions to the device may reduce device reliability. Specified typical performance or

functional operation of the device under Absolute Maximum Rating conditions is not impli

Nominal Operating Parameters

Parameter	Specification			Unit	Condition
	Min	Typ	Max		
General Performance					V+ = 24V; T_{MB} = 30°C; Z_S = Z_L = 75Ω
Power Gain	18.5	19.0	19.5	dB	f = 45MHz
	20.0	20.5	21.5	dB	f = 1000MHz
Slope ^[1]	1.0	1.5	2.5	dB	f = 45MHz to 1000MHz
Flatness of Frequency Response			0.8	dB	f = 45MHz to 1000MHz (Peak to Valley)
Input Return Loss	20			dB	f = 45MHz to 320MHz
	19			dB	f = 320MHz to 640MHz
	18			dB	f = 640MHz to 870MHz
	16			dB	f = 870MHz to 1000MHz
Output Return Loss	20			dB	f = 45MHz to 320MHz
	19			dB	f = 320MHz to 640MHz
	18			dB	f = 640MHz to 870MHz
	17			dB	f = 870MHz to 1000MHz
Noise Figure		3.0	4.0	dB	f = 50MHz to 1000MHz
Total Current Consumption (DC)		430.0	450.0	mA	
Distortion Data 40MHz to 550MHz					V+ = 24V; T_{MB} = 30°C; Z_S = Z_L = 75Ω
CTB		-77	-74	dBc	79 ch 7 dB tilted; V ₀ = 50dBmV at 550MHz, plus 75 digital channels (-6dB offset) ^[2]
XMOD		-71	-68	dBc	
CSO		-71	-68	dBc	
CIN	65	68		dB	

1. The slope is defined as the difference between the gain at the start frequency and the gain at the stop frequency.

2. 79 analog channels, NTSC frequency raster: 55.25MHz to 547.25MHz, +43dBmV to +50dBmV tilted output level, plus 75 digital channels, -6dB offset relative to the equivalent analog carrier.

Composite Second Order (CSO) - The CSO parameter (both sum and difference products) is defined by the NCTA.

Composite Triple Beat (CTB) - The CTB parameter is defined by the NCTA.

Cross Modulation (XMOD) - Cross modulation (XMOD) is measured at baseband (selective voltmeter method), referenced to 100% modulation of the carrier being tested.

Carrier to Intermodulation Noise (CIN) - The CIN parameter is defined by ANSI/SCTE 17 (Test Procedure for Carrier to Noise).

Package Drawing (Dimensions in millimeters)

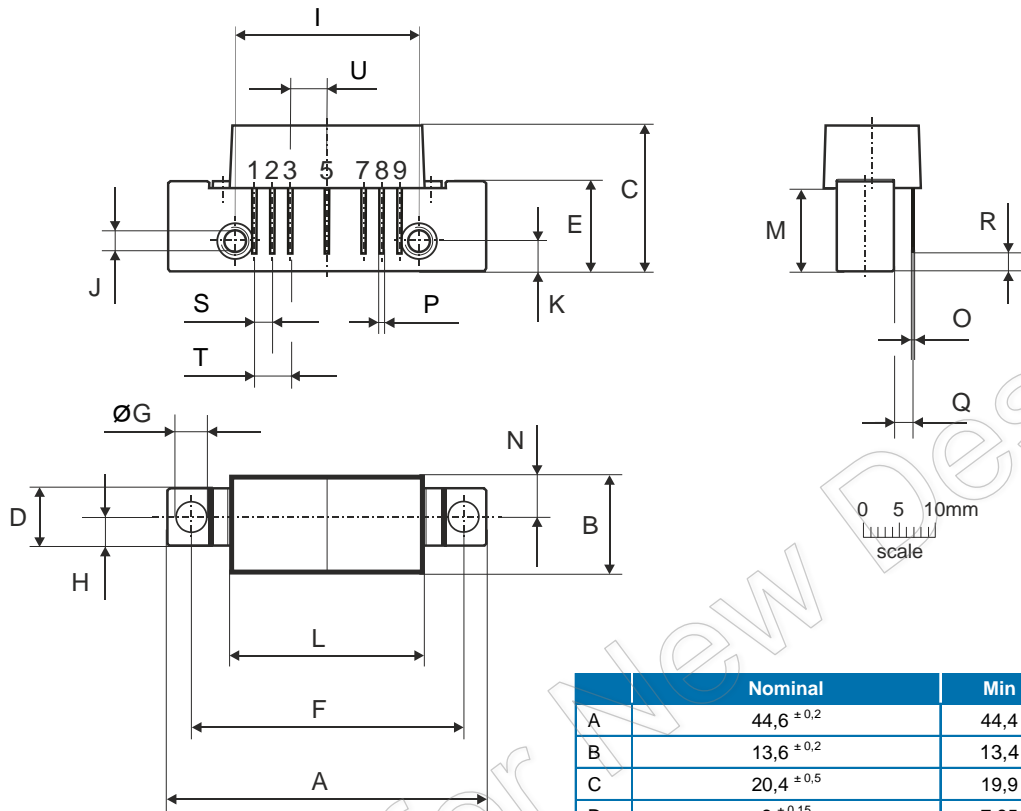

Notes:



Pinning:

Pin	Name
1	Input
2-3	GND
4	
5	+VB
6	
7-8	GND
9	Output

	Nominal	Min	Max
A	44,6 ± 0,2	44,4	44,8
B	13,6 ± 0,2	13,4	13,8
C	20,4 ± 0,5	19,9	20,9
D	8 ± 0,15	7,85	8,15
E	12,6 ± 0,15	12,45	12,75
F	38,1 ± 0,2	37,9	38,3
G	4 ^{+0,2 / -0,05}	3,95	4,2
H	4 ± 0,2	3,8	4,2
I	25,4 ± 0,2	25,2	25,6
J	UNC 6-32	-	-
K	4,2 ± 0,2	4,0	4,4
L	27,2 ± 0,2	27,0	27,4
M	11,6 ± 0,5	11,1	12,1
N	5,8 ± 0,4	5,4	6,2
O	0,25 ± 0,02	0,23	0,27
P	0,45 ± 0,03	0,42	0,48
Q	2,54 ± 0,3	2,24	2,84
R	2,54 ± 0,5	2,04	3,04
S	2,54 ± 0,25	2,29	2,79
T	5,08 ± 0,25	4,83	5,33
U	5,08 ± 0,25	4,83	5,33