

MN6577F, MN6577H

Low Power 10-Bit 3-Volt CMOS A/D Converters for Image Processing

■ Overview

The MN6577F and MN6577H are high-speed 10-bit CMOS analog-to-digital converters for image processing applications.

They use a half flash structure based on chopper comparators to achieve both high speed and low power consumption, and operate on a single 3 volt power supply.

■ Features

- Maximum conversion rate: 15 MSPS (min.)
- Linearity error: ± 1.3 LSB (typ.)
- Differential linearity error: ± 0.5 LSB (typ.)
- Power supply voltage: 3.0 V
- Power consumption: 40 mW (typ.) ($f_{CLK}=15$ MHz)

■ Applications

- Digital television
- Digital video equipment
- Digital image processing equipment

■ Pin Assignment

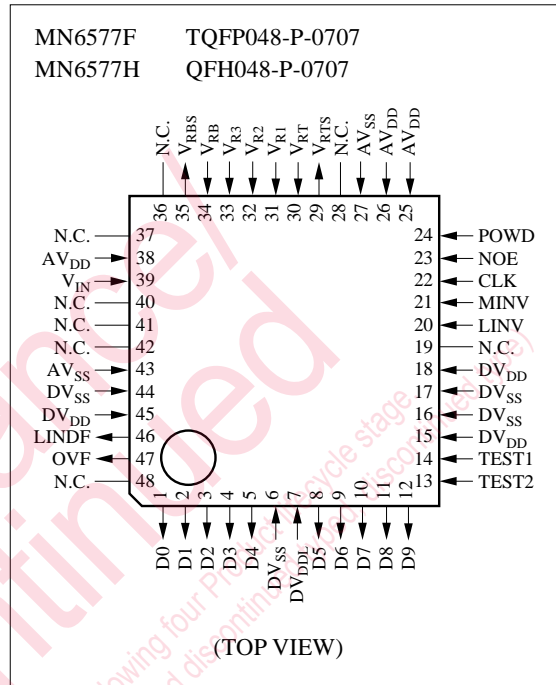

■ Pin Descriptions

Pin No.	Symbol	Function Description
1	D0	Digital code output (LSB)
2	D1	Digital code output
3	D2	Digital code output
4	D3	Digital code output
5	D4	Digital code output
6	DV _{SS}	Ground for digital circuits
7	DV _{DD}	Power supply for digital circuits
8	D5	Digital code output
9	D6	Digital code output
10	D7	Digital code output
11	D8	Digital code output
12	D9	Digital code output (MSB)
13	TEST2	Test mode selection pin
14	TEST1	Test mode selection pin
15	DV _{DD}	Power supply for digital circuits
16	DV _{SS}	Ground for digital circuits
17	DV _{SS}	Ground for digital circuits
18	DV _{DD}	Power supply for digital circuits
19	N.C.	No connection
20	LINV	Output inversion pin
21	MINV	Output inversion pin
22	CLK	Sampling clock
23	NOE	Digital output enable pin
24	POWD	Power down mode selection pin
25	AV _{DD}	Power supply for analog circuits
26	AV _{DD}	Power supply for analog circuits
27	AV _{SS}	Ground for analog circuits
28	N.C.	No connection
29	V _{RTS}	Reference voltage power supply (TOP)
30	V _{RT}	Reference voltage input (TOP)
31	V _{R1}	Intermediate reference voltage
32	V _{R2}	Intermediate reference voltage
33	V _{R3}	Intermediate reference voltage
34	V _{RB}	Reference voltage input (BOTTOM)
35	V _{RBS}	Reference voltage power supply (BOTTOM)
36	N.C.	No connection
37	N.C.	No connection
38	AV _{DD}	Power supply for analog circuits
39	V _{IN}	Analog signal input
40	N.C.	No connection

■ Pin Description (continued)

Pin No.	Symbol	Function Description
41	N.C.	No connection
42	N.C.	No connection
43	AV _{SS}	Ground for analog circuits
44	DV _{SS}	Ground for digital circuits
45	DV _{DD}	Power supply for digital circuits
46	UNDF	Underflow output
47	OVF	Overflow output
48	N.C.	No connection

■ Absolute Maximum Ratings $T_a=25^\circ\text{C}$

Parameter	Symbol	Rating	Unit
Power supply voltage	V _{DD}	- 0.3 to +7.0	V
Input voltage	V _I	- 0.3 to V _{DD} +0.3	V
Output voltage	V _O	- 0.3 to V _{DD} +0.3	V
Operating ambient temperature	T _{opr}	-20 to +70	°C
Storage temperature	T _{stg}	-55 to +125	°C

■ Recommended Operating Conditions $V_{DD}=AV_{DD}=DV_{DD}=3.0\text{V}$, $V_{SS}=AV_{SS}=DV_{SS}=0\text{V}$, $T_a=25^\circ\text{C}$

Parameter	Symbol	min	typ	max	Unit
Power supply voltage	V _{DD}	2.85	3.00	3.30	V
Digital input voltage	"H" level	V _{IH}	2.4	V _{DD}	V
	"L" level	V _{IL}	V _{SS}	0.8	V
Reference voltage	"H" level	V _{RT}	2.0	V _{DD}	V
	"L" level	V _{RB}	V _{SS}	1.0	V
Clock	"H" level pulse width	t _{WH}	30		ns
	"L" level pulse width	t _{WL}	30		ns
Analog input voltage	V _{AIN}	V _{SS}		V _{DD}	V

■ Electrical Characteristics $V_{DD}=AV_{DD}=DV_{DD}=3.0\text{V}$, $AV_{SS}=DV_{SS}=0\text{V}$, $T_a=25^\circ\text{C}$

Parameter	Symbol	Conditions	min	typ	max	Unit
Power consumption	P _C	F _C =15MSPS (not including reference current)		39	72	mW
Resolution	RES			10		bit
Linearity error	E _L	f _{CLK} =15MSPS		±1.3	±2.5	LSB
Differential linearity error	E _D	V _{RT} =3.0V V _{BB} =1.0V		±0.5	±1.0	LSB
Maximum conversion rate	F _{C(max.)}		15			MSPS
Clock frequency	f _{CLK}		1		15	MHz
Analog input dynamic range	D _R		2		V _{RT} - V _{RB}	V
Output current	"H" level	I _{OH}	V _{OH} =V _{DD} - 0.8V		-1.5	mA
	"L" level	I _{OL}	V _{OL} =0.4V	1.5		mA
Output delay time	t _d	C _L =20pF	10	20	40	ns
Analog input capacitance	C _I			18		pF
Sampling delay	t _{sd}			7		ns

■ Timing Chart

The chip samples the analog input at the falling edge of the clock signal and provides the corresponding digital output 2.5 clock cycles later at the rising edge of the clock signal.

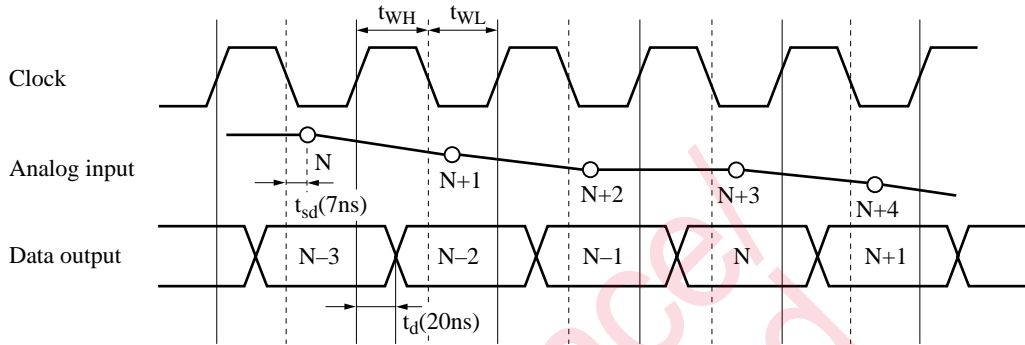

Note: The circles indicate analog signal sampling points.

■ Package Dimensions (Unit: mm)

- MN6577F: TQFP048-P-0707

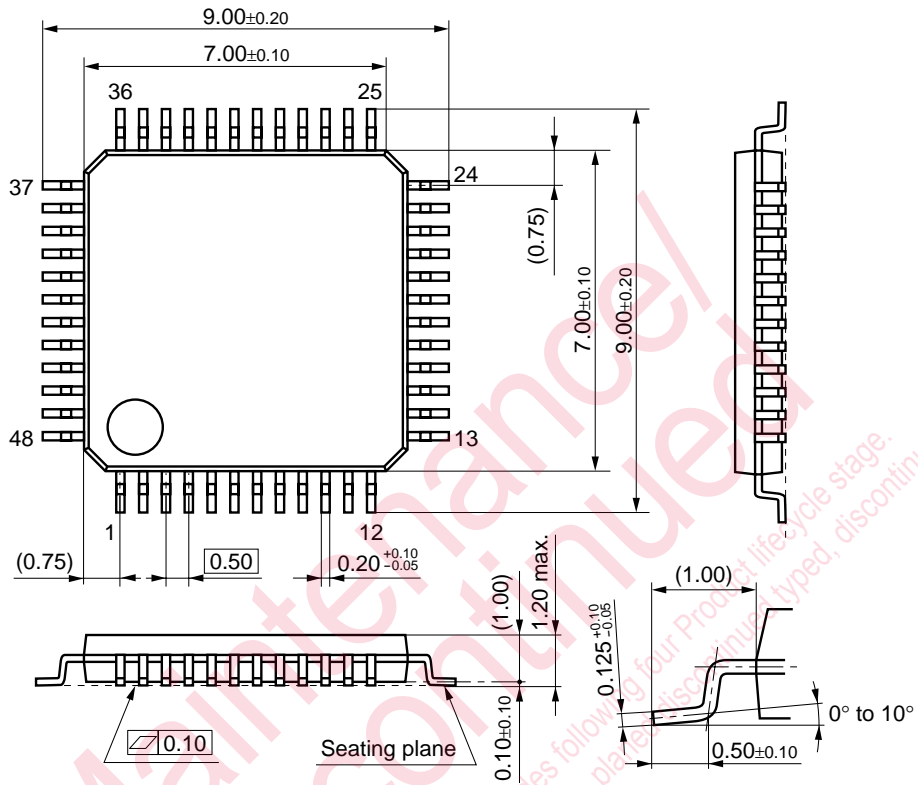

Note) The package will be changed to lead-free type (TQFP048-P-0707B).

■ Package Dimensions (Unit: mm)(continued)

- MN6577H: QFH048-P-0707

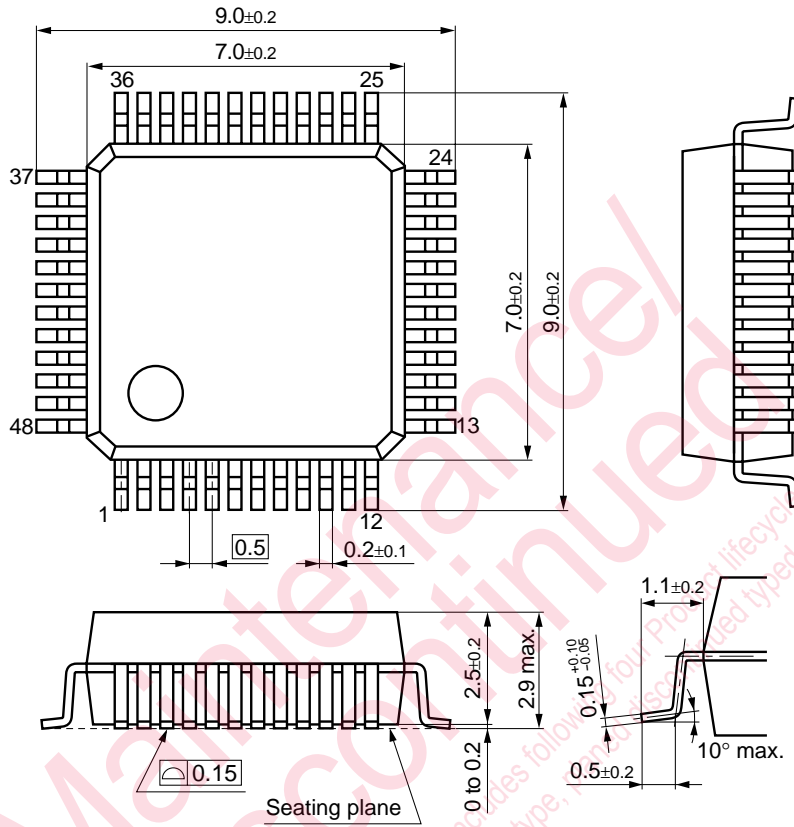

Note) The package will be changed to lead-free type (QFH048-P-0707B).

■ New Package Dimensions (Unit: mm)

- MN6577F: TQFP048-P-0707B (Lead-free package)

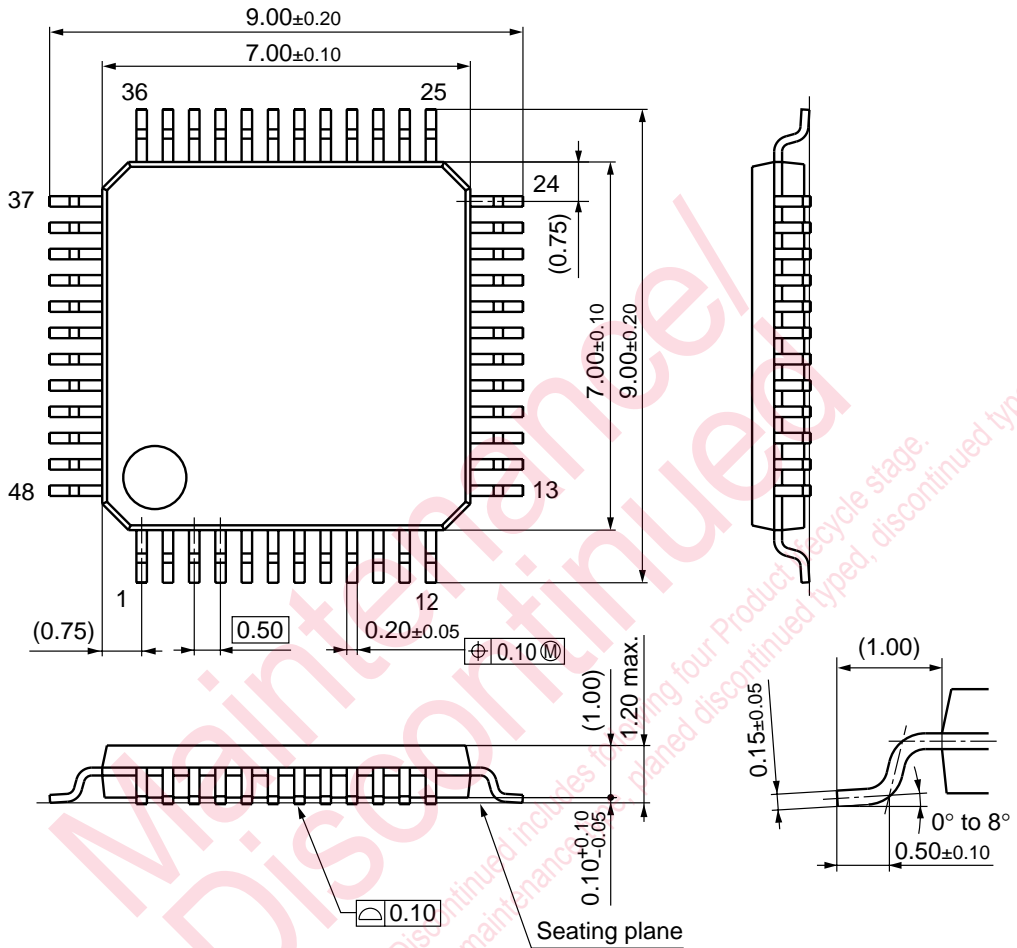

Request for your special attention and precautions in using the technical information and semiconductors described in this book

- (1) If any of the products or technical information described in this book is to be exported or provided to non-residents, the laws and regulations of the exporting country, especially, those with regard to security export control, must be observed.
- (2) The technical information described in this book is intended only to show the main characteristics and application circuit examples of the products, and no license is granted under any intellectual property right or other right owned by our company or any other company. Therefore, no responsibility is assumed by our company as to the infringement upon any such right owned by any other company which may arise as a result of the use of technical information described in this book.
- (3) The products described in this book are intended to be used for standard applications or general electronic equipment (such as office equipment, communications equipment, measuring instruments and household appliances).
Consult our sales staff in advance for information on the following applications:
 - Special applications (such as for airplanes, aerospace, automobiles, traffic control equipment, combustion equipment, life support systems and safety devices) in which exceptional quality and reliability are required, or if the failure or malfunction of the products may directly jeopardize life or harm the human body.
 - Any applications other than the standard applications intended.
- (4) The products and product specifications described in this book are subject to change without notice for modification and/or improvement. At the final stage of your design, purchasing, or use of the products, therefore, ask for the most up-to-date Product Standards in advance to make sure that the latest specifications satisfy your requirements.
- (5) When designing your equipment, comply with the range of absolute maximum rating and the guaranteed operating conditions (operating power supply voltage and operating environment etc.). Especially, please be careful not to exceed the range of absolute maximum rating on the transient state, such as power-on, power-off and mode-switching. Otherwise, we will not be liable for any defect which may arise later in your equipment.
 - Even when the products are used within the guaranteed values, take into the consideration of incidence of break down and failure mode, possible to occur to semiconductor products. Measures on the systems such as redundant design, arresting the spread of fire or preventing glitch are recommended in order to prevent physical injury, fire, social damages, for example, by using the products.
- (6) Comply with the instructions for use in order to prevent breakdown and characteristics change due to external factors (ESD, EOS, thermal stress and mechanical stress) at the time of handling, mounting or at customer's process. When using products for which damp-proof packing is required, satisfy the conditions, such as shelf life and the elapsed time since first opening the packages.
- (7) This book may be not reprinted or reproduced whether wholly or partially, without the prior written permission of Matsushita Electric Industrial Co., Ltd.