

SDL 6300 SERIES

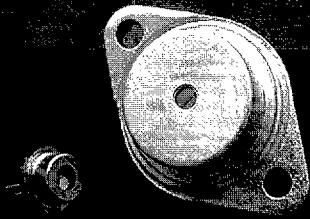

Key Features

- 1017 nm Output
- Single Transverse Mode
- 100 mW cw Power
- Diffraction Limited Beam
- Praseodymium Fiber Amplifier Pumps
- TEC Package Available

1017 nm, 100 mW CW InGaAs LASER DIODES

Ideal for optical pumping Praseodymium doped fiber amplifiers, the SDL-6300 Series InGaAs laser diodes provide high power in a single transverse mode, diffraction limited beam for efficient coupling into single mode fibers. 100 mW cw chips allow high launched power in single mode fibers and high amplifier gain.

Low threshold current and high slope efficiency contribute to low operating currents, enhancing reliability. Lifetime compatible with communications systems and CATV network requirements has been demonstrated at the 100 mW power level.

Coupling efficiency into single mode fiber exceeding 50% has commonly been achieved in production environments, allowing well over 50 mW launched power. This high pump power permits very high amplifier gain at low noise levels. Laser diode wavelength tolerance options are compatible with absorption bandwidths of doped fiber.

The Indium strained layer, single quantum well index guided laser diode is available in a variety of packages for OEM or scientific applications. The TO-3 package includes an internal thermoelectric cooler for wavelength control. SOT-148 packaging permits miniaturized installations. The SDL-6310-C open heatsink package allows compact mounting in customer systems.



CW High Power/Brightness
Laser Diodes/Linear Arrays

CW Single Spatial/Longitudinal
Mode Laser Diodes

CW Single Spatial Mode
Laser Diodes
SDL-6300

Individually Addressable
Array Laser Diodes

High Power Fiber-Coupled
Linear Arrays

CW Tunable
Laser Diodes

CW Linear Arrays
and Stacked Arrays

Pulsed and CW
Laser Diodes

Laser Diode Drivers,
Systems and Heatsinks

Specifications

(Typical values at 25 °C and 0.6 NA collection optics)

Model Number	CW Output Power (mW)	Differential Quantum Efficiency (mW/mA)	Total Conversion Efficiency (%)	Emitting Dimensions W x H (µm)	Beam Divergence $\theta_{\perp}, \theta_{\parallel}$ (deg FWHM)	Threshold Current (mA)	Operating Current (mA)
SDL-6310-C	100	0.69 (54%)	30	3.0 x 1.0	30, 10	15	160
SDL-6310-G1	100	0.69 (54%)	30	3.0 x 1.0	30, 10	15	160
SDL-6312-H1	100	0.69 (54%)	30	3.0 x 1.0	30, 10	15	160

Notes

- Features common to all SDL-6300 Series laser diodes include:
 - Duty factor of 100%.
 - Thermal tuning of the wavelength of the SDL-6300 can be achieved by varying the temperature. This will result in a wavelength change of 0.22 nm/deg.
 - Temperature coefficient of threshold current can be modeled as:

$$I_{TH2} = I_{TH1} \exp[(T_2 - T_1)/T_0]$$
 where T_0 is a device constant of about 110°K.
 - Temperature coefficient of operating current is approximately 0.5 - 0.7% per °C.

- Forward Voltage is typically: $V_f = 1.5 V + I_{op} \times R_s$
- Wavelength range of the SDL-6300 Series is ~ 1010 to 1020 nm.
- Thermoelectric Cooler** (available on "H1" pkg. only)
 - Maximum Drive Current: 2.0 A
 - Maximum Drive Voltage: 4.0 V
 - Thermal Resistance: 15 °C/W
 - Thermistor R @ 25 °C: 10 k Ω

- Definition of Part Numbers:

SDL-631X - (C, G1, or H1 package)

- 0 - No Options
- 2 - TE Cooler

Optical Characteristics

LIGHT vs. CURRENT CHARACTERISTICS

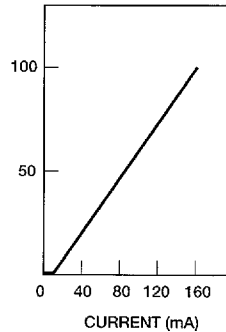

TYPICAL EMISSION SPECTRUM

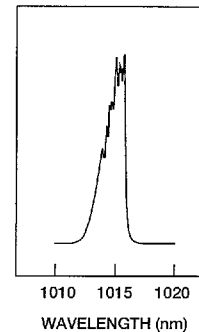

FARFIELD ENERGY DISTRIBUTION

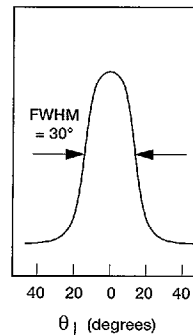

FARFIELD ENERGY DISTRIBUTION

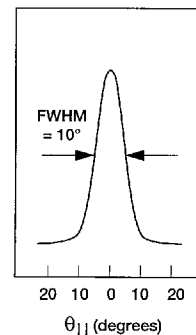

Absolute Maximum Ratings

Series Resistance (Ω)	Thermal Resistance ($^{\circ}\text{C}/\text{W}$)	Recommended Case Temperature ($^{\circ}\text{C}$)	CW Output Power (mW)	Reverse Voltage (volts)	Case Operating Temperature ($^{\circ}\text{C}$)	Storage Temperature Range ($^{\circ}\text{C}$)	Lead Soldering Temperature ($^{\circ}\text{C}$ for 5 sec)
4.0	60	-20 to 30	110	2.5	30	-20 to 40	250
4.0	60	-20 to 30	110	2.5	30	-20 to 40	250
4.0	NA	-20 to 30	110	2.5	30	-20 to 40	250

Package Specifications [Dimensions in inches (mm) except where indicated]

SDL Standard Tolerances: (unless otherwise specified)

inches: x.xx = ± 0.02
x.xxx = ± 0.010

mm: x.x = ± 0.5
x.xx = ± 0.25

C OPEN HEATSINK PACKAGE

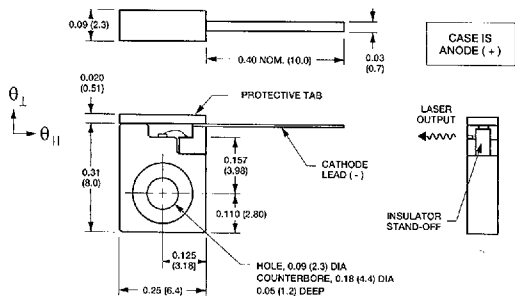

H1 TO-3 WINDOW PACKAGE

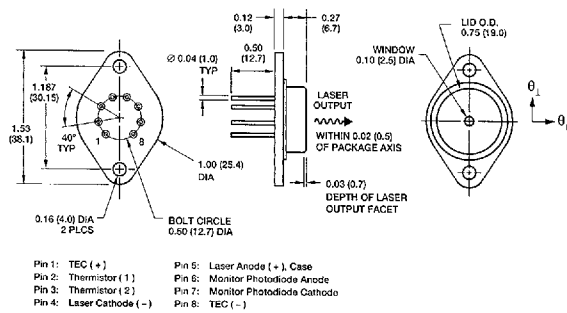

G1 SOT-148 WINDOW PACKAGE

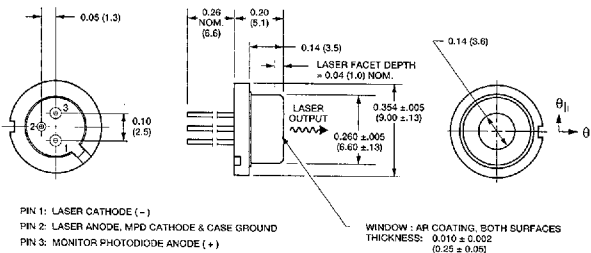

SDL-6300 SERIES

Safety And Operating Considerations

The laser light emitted from this laser diode is invisible and may be harmful to the human eye. Avoid looking directly into the laser diode, into the collimated beam along its optical axis when the device is in operation.

CAUTION: THE USE OF OPTICAL INSTRUMENTS WITH THIS PRODUCT WILL INCREASE EYE HAZARD.

Operating the laser diode outside of its maximum ratings may cause device failure or a safety hazard. Power supplies used with the component must be employed such that the maximum peak optical power cannot be exceeded. CW laser diodes may be damaged by excessive drive current or switching transients. When using power supplies, the laser diode should be connected with the main power on and the output voltage at zero. The current should be increased slowly while monitoring the laser diode output power and the drive current.

Device degradation accelerates with increased temperature and therefore careful attention to minimize the case temperature is advised. For example, life expectancy will decrease by a factor of four if the case is operated at 50 °C rather than 30 °C.

A proper heat sink for the laser diode on a thermal radiator will greatly enhance laser life. Firmly mount the laser on a radiator having a thermal impedance of less than 2.0 °C/W for increased reliability.

ESD PROTECTION — Electro-static discharge is the primary cause of unexpected laser diode failure. Take extreme precaution to prevent ESD. Use wrist straps, grounded work surfaces, and rigorous anti-static techniques when handling laser diodes.

21 CFR 1040.10 Compliance

Because of the small size of these devices, each of the labels shown is attached to the individual shipping container. They are illustrated here to comply with 21 CFR 1040.10 as applicable under the radiations control for health and safety act of 1968.

SERIAL NUMBER IDENTIFICATION LABEL

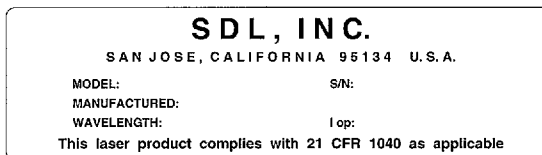

OUTPUT POWER DANGER LABEL



PACKAGE APERTURE LABELS

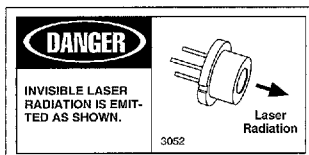

"G1" PACKAGE DIODES

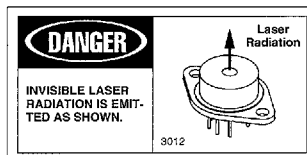

"H1" PACKAGE DIODES

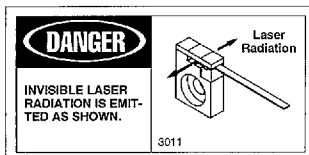

"C" PACKAGE DIODES

CW High Power/Brightness Laser Diodes/Linear Arrays
 CW Single Spatial/Longitudinal Mode Laser Diodes
 SDL-6300 CW Single Spatial Mode Laser Diodes
 Individually Addressable Array Laser Diodes
 High Power Fiber-Coupled Linear Arrays
 CW Tunable Laser Diodes
 QCW Linear Arrays and Stacked Arrays
 Pulsed and QCW Laser Diodes
 Laser Diode Drivers, Systems and Heatinks