



Please note that Cypress is an Infineon Technologies Company.

The document following this cover page is marked as “Cypress” document as this is the company that originally developed the product. Please note that Infineon will continue to offer the product to new and existing customers as part of the Infineon product portfolio.

Continuity of document content

The fact that Infineon offers the following product as part of the Infineon product portfolio does not lead to any changes to this document. Future revisions will occur when appropriate, and any changes will be set out on the document history page.

Continuity of ordering part numbers

Infineon continues to support existing part numbers. Please continue to use the ordering part numbers listed in the datasheet for ordering.

Low-Speed High Input/Output 1.5-Mbps USB Controller

Features

- Low-cost solution for low-speed applications with high I/O requirements such as keyboards, keyboards with integrated pointing device, gamepads, and many others
- USB Specification compliance
 - Conforms to USB Specification, Versions 1.1 and 2.0
 - Conforms to USB HID Specification, Version 1.1
 - Supports one device address and three data endpoints
 - Integrated USB transceiver
- 8-bit RISC microcontroller
 - Harvard architecture
 - 6-MHz external ceramic resonator
 - 12-MHz internal CPU clock
- Internal memory
 - 256 bytes of RAM
 - 8 Kbytes of EPROM
- Interface can auto-configure to operate as PS2 or USB
- I/O port
 - The CY7C63413C/513C have 24 general purpose I/O (GPIO) pins (Port 0 to 2) capable of sinking 7 mA per pin (typical)
 - The CY7C63613C has 12 GPIO pins (Port 0 to 2) capable of sinking 7 mA per pin (typical)
 - The CY7C63413C/513C have eight GPIO pins (Port 3) capable of sinking 12 mA per pin (typical) which can drive LEDs
 - The CY7C63613C has four GPIO pins (Port 3) capable of sinking 12 mA per pin (typical) which can drive LEDs
 - Higher current drive is available by connecting multiple GPIO pins together to drive a common output
 - Each GPIO port can be configured as inputs with internal pull-ups or open drain outputs or traditional CMOS outputs
 - The CY7C63513C has an additional eight I/O pins on a DAC port which has programmable current sink outputs
 - Maskable interrupts on all I/O pins
- 12-bit free-running timer with one microsecond clock ticks
- Watch Dog Timer (WDT)
- Internal Power-On Reset (POR)
- Improved output drivers to reduce EMI
- Operating voltage from 4.0 V to 5.5 V DC
- Operating temperature from 0 to 70 °C
- CY7C63413C available in 40-pin PDIP, 48-pin SSOP, 48-pin SSOP - Tape reel, all in Pb-free versions for production
- CY7C63513C available in 48-pin SSOP Pb-free packages for production
- CY7C63613C available in 24-pin SOIC Pb-free packages for production
- Industry-standard programmer support

Functional Description

The CY7C63413C/513C/613C are 8-bit RISC one time programmable (OTP) microcontrollers. The instruction set has been optimized specifically for USB operations, although the microcontrollers can be used for a variety of non-USB embedded applications.

The CY7C63413C/513C features 32 GPIO pins to support USB and other applications. The I/O pins are grouped into four ports (Port 0 to 3) where each port can be configured as inputs with internal pull-ups, open drain outputs, or traditional CMOS outputs. The CY7C63413C/513C have 24 GPIO pins (Ports 0 to 2) that are rated at 7 mA typical sink current. The CY7C63413C/513C has 8 GPIO pins (Port 3) that are rated at 12 mA typical sink current, which allows these pins to drive LEDs.

The CY7C63613C features 16 GPIO pins to support USB and other applications. The I/O pins are grouped into four ports (Port 0 to 3) where each port can be configured as inputs with internal pull-ups, open drain outputs, or traditional CMOS outputs. The CY7C63613C has 12 GPIO pins (Ports 0 to 2) that are rated at 7 mA typical sink current. The CY7C63613C has four GPIO pins (Port 3) that are rated at 12 mA typical sink current, which allows these pins to drive LEDs.

Multiple GPIO pins can be connected together to drive a single output for more drive current capacity. Additionally, each I/O pin can be used to generate a GPIO interrupt to the microcontroller. Note the GPIO interrupts all share the same "GPIO" interrupt vector.

The CY7C63513C features an additional 8 I/O pins in the DAC port. Every DAC pin includes an integrated 14-KΩ pull-up resistor. When a "1" is written to a DAC I/O pin, the output current sink is disabled and the output pin is driven high by the internal pull-up resistor. When a "0" is written to a DAC I/O pin, the internal pull-up is disabled and the output pin provides the programmed amount of sink current. A DAC I/O pin can be used as an input with an internal pull-up by writing a "1" to the pin.

The sink current for each DAC I/O pin can be individually programmed to one of sixteen values using dedicated Isink registers. DAC bits [1:0] can be used as high current outputs with a programmable sink current range of 3.2 to 16 mA (typical). DAC bits [7:2] have a programmable current sink range of 0.2 to 1.0 mA (typical). Again, multiple DAC pins can be connected together to drive a single output that requires more sink current capacity. Each I/O pin can be used to generate a DAC interrupt to the microcontroller and the interrupt polarity for each DAC I/O pin is individually programmable. The DAC port interrupts share a separate "DAC" interrupt vector.

The Cypress microcontrollers use an external 6-MHz ceramic resonator to provide a reference to an internal clock generator. This clock generator reduces the clock-related noise emissions (EMI). The clock generator provides the 6 and 12-MHz clocks that remain internal to the microcontroller.



The CY7C63413C/513C/613C are offered with single EPROM options. The CY7C63413C, CY7C63513C and the CY7C63613C have 8 Kbytes of EPROM.

These parts include Power-on Reset logic, a Watch Dog Timer, a vectored interrupt controller, and a 12-bit free-running timer. The Power-On Reset (POR) logic detects when power is applied to the device, resets the logic to a known state, and begins executing instructions at EPROM address 0x0000. The Watch Dog Timer can be used to ensure the firmware never gets stalled for more than approximately 8 ms. The firmware can get stalled for a variety of reasons, including errors in the code or a hardware failure such as waiting for an interrupt that never occurs. The firmware should clear the Watch Dog Timer periodically. If the Watch Dog Timer is not cleared for approximately 8 ms, the microcontroller will generate a hardware watch dog reset.

The microcontroller supports eight maskable interrupts in the vectored interrupt controller. Interrupt sources include the USB Bus-Reset, the 128- μ s and 1.024-ms outputs from the free-running timer, three USB endpoints, the DAC port, and the GPIO ports. The timer bits cause an interrupt (if enabled) when the bit toggles from LOW "0" to HIGH "1". The USB endpoints interrupt after either the USB host or the USB controller sends a packet to the USB. The DAC ports have an additional level of masking that allows the user to select which DAC inputs can cause a DAC interrupt. The GPIO ports also have a level of masking to select which GPIO inputs can cause a GPIO interrupt. For additional flexibility, the input transition polarity that

causes an interrupt is programmable for each pin of the DAC port. Input transition polarity can be programmed for each GPIO port as part of the port configuration. The interrupt polarity can be either rising edge ("0" to "1") or falling edge ("1" to "0").

The free-running 12-bit timer clocked at 1 MHz provides two interrupt sources as noted above (128- μ s and 1.024-ms). The timer can be used to measure the duration of an event under firmware control by reading the timer twice: once at the start of the event, and once after the event is complete. The difference between the two readings indicates the duration of the event measured in microseconds. The upper four bits of the timer are latched into an internal register when the firmware reads the lower eight bits. A read from the upper four bits actually reads data from the internal register, instead of the timer. This feature eliminates the need for firmware to attempt to compensate if the upper four bits happened to increment right after the lower 8 bits are read.

The CY7C63413C/513C/613C include an integrated USB serial interface engine (SIE) that supports the integrated peripherals. The hardware supports one USB device address with three endpoints. The SIE allows the USB host to communicate with the function integrated into the microcontroller.

Finally, the CY7C63413C/513C/613C support PS/2 operation. With appropriate firmware the D+ and D- USB pins can also be used as PS/2 clock and data signals. Products utilizing these devices can be used for USB and/or PS/2 operation with appropriate firmware.



Contents

Pin Configuration	4	USB Device	20
Pin Definitions	5	USB Ports	20
Die Pad Locations	6	Device Endpoints (3)	20
Programming Model	7	12-bit Free-running Timer	22
14-bit Program Counter (PC)	7	Timer (LSB)	22
8-bit Accumulator (A)	7	Timer (MSB)	22
8-bit Index Register (X)	7	Processor Status and Control Register	23
8-bit Program Stack Pointer (PSP)	7	Interrupts	23
8-bit Data Stack Pointer (DSP)	7	Interrupt Vectors	24
Address Modes	8	Interrupt Latency	24
Instruction Set Summary	9	Truth Tables	25
Memory Organization	10	Absolute Maximum Ratings	29
Program Memory Organization	10	DC Characteristics	29
Data Memory Organization	11	Switching Characteristics	31
I/O Register Summary	12	Ordering Information	34
Clocking	13	Ordering Code Definitions	34
Reset	13	Package Diagrams	35
Power-On Reset (POR)	13	Acronyms	37
Watch Dog Reset (WDR)	13	Document Conventions	37
General Purpose I/O Ports	14	Units of Measure	37
GPIO Interrupt Enable Ports	15	Document History Page	38
GPIO Configuration Port	15	Sales, Solutions, and Legal Information	39
DAC Port	17	Worldwide Sales and Design Support	39
DAC Port Interrupts	17	Products	39
DAC Isink Registers	18	PSoC® Solutions	39
USB Serial Interface Engine (SIE)	19	Cypress Developer Community	39
USB Enumeration	19	Technical Support	39
PS/2 Operation	19		
USB Port Status and Control	19		



Logic Block Diagram

6-MHz Ceramic Resonator

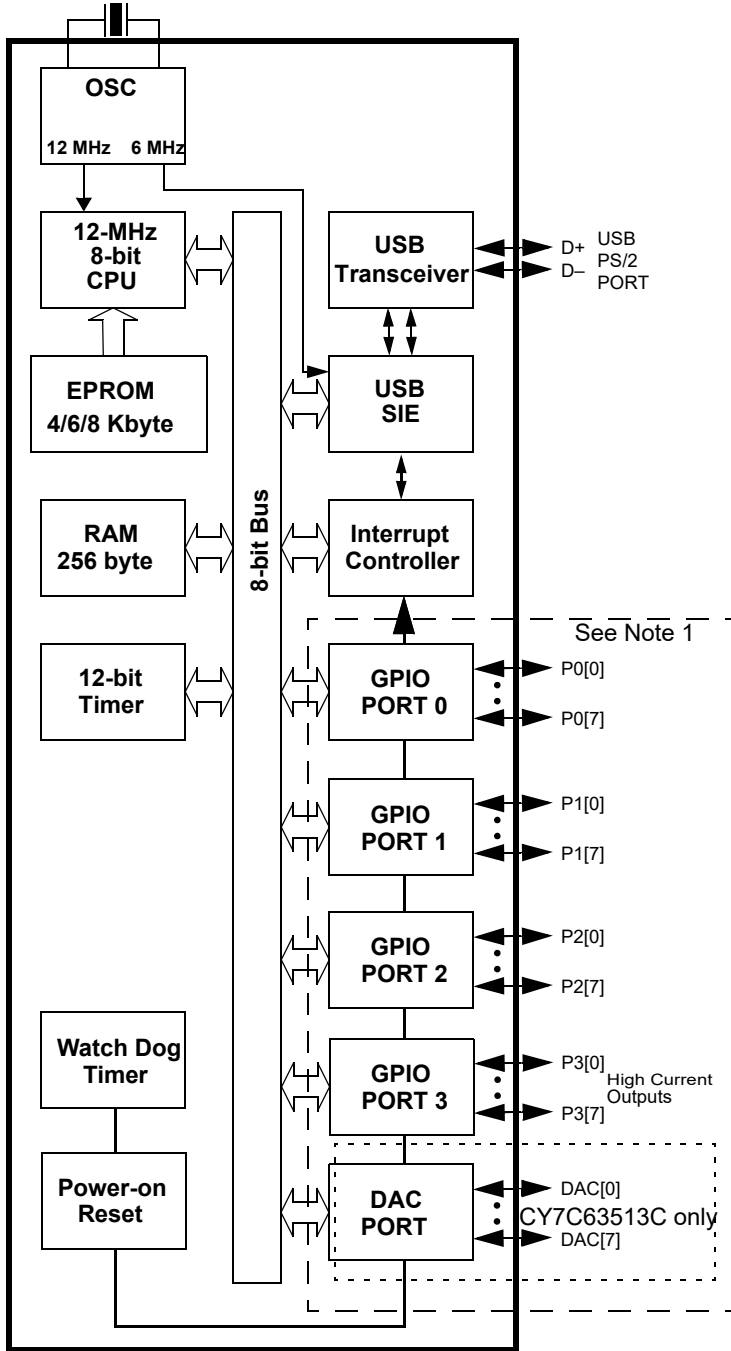

Pin Configuration

CY7C63513C
 48-pin SSOP

CY7C63413C
 48-pin SSOP

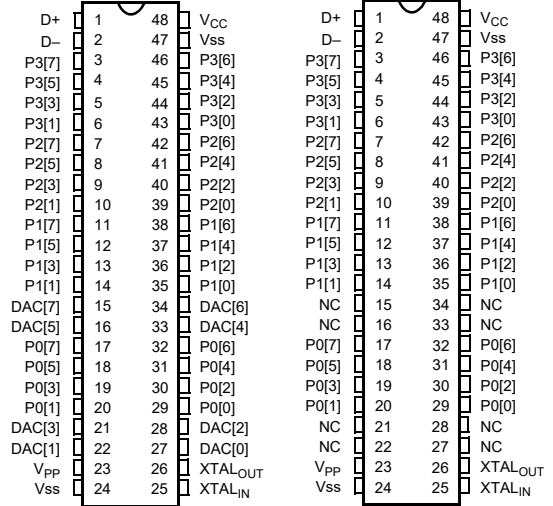

CY7C63613C
 24-pin SOIC

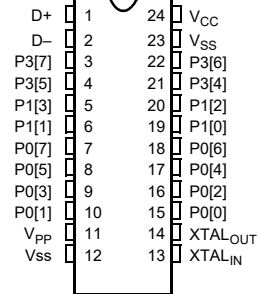

CY7C63413C
 48-Pad Die

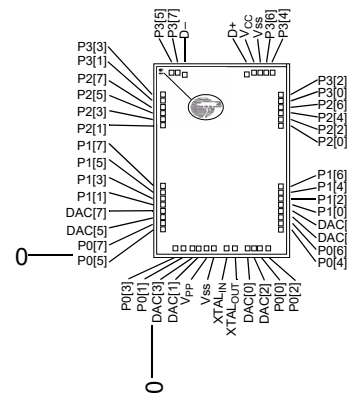

Note

1. CY7C63613C is not bonded out for all GPIO pins shown in Logic Block Diagram. Refer to pin configuration diagram for bonded out pins. See note on page 12 for firmware code needed for unused GPIO pins.



Pin Definitions

Name	I/O	CY7C63413C		Die	CY7C63513C	CY7C63613C	Description
		40-Pin	48-Pin		48-Pin	24-Pin	
D+, D-	I/O	1, 2	1, 2	1, 2	1, 2	1, 2	USB differential data; PS/2 clock and data signals
P0[7:0]	I/O	15,26,162 5,17,24,18, 23	17,32,183 1,19,30,20, 29	17,32,18, 31,19,30, 20,29	17,32,18,31, 19,30,20,29	7, 18, 8, 17, 9, 16, 10, 15	GPIO port 0 capable of sinking 7 mA (typical)
P1[3:0]	I/O	11,30,12,2 9,13,28,14 ,27	11,38,12,3 7,13,36,14 ,35	11,38,12, 37,13,36, 14,35	11,38,12,37, 13,36,14,35	5, 20, 6, 19	GPIO Port 1 capable of sinking 7 mA (typical).
P2	I/O	7,34,8, 33,9,32, 10,31	7,42,8, 41,9,40, 10,39	7,42,8, 41,9,40, 10,39	7,42,8,41,9, 40,10,39	n/a	GPIO Port 2 capable of sinking 7 mA (typical).
P3[7:4]	I/O	3,38,4, 37,5,36, 6,35	3,46,4, 45,5,44, 6,43	3,46,4, 45,5,44, 6,43	3,46,4,45,5, 44,6,43	3, 22, 4, 21	GPIO Port 3 capable of sinking 12 mA (typical).
DAC	I/O	n/a	n/a	15,34,16, 33,21,28, 22,27	15,34,16,33, 21,28,22,27	n/a	DAC I/O Port with programmable current sink outputs. DAC[1:0] offer a programmable range of 3.2 to 16 mA typical. DAC[7:2] have a programmable sink current range of 0.2 to 1.0 mA typical. DAC I/O Port not bonded out on CY7C63613C. See note on page 12 for firmware code needed for unused pins.
XTAL _{IN}	IN	21	25	25	25	13	6-MHz ceramic resonator or external clock input
XTAL _{OUT}	OUT	22	26	26	26	14	6-MHz ceramic resonator
V _{PP}		19	23	23	23	11	Programming voltage supply, ground during operation
V _{CC}		40	48	48	48	24	Voltage supply
V _{SS}		20,39	24,47	24,47	24,47	12, 23	Ground



Die Pad Locations

Table 1. Die Pad Locations (in microns)

Pad #	Pin Name	X	Y	Pad #	Pin Name	X	Y
1	D+	1496.95	2995.00	48	V _{CC}	1619.65	3023.60
2	D-	467.40	2995.00	47	V _{SS}	1719.65	3023.60
3	Port3[7]	345.15	3023.60	46	Port3[6]	1823.10	3023.60
4	Port3[5]	242.15	3023.60	45	Port3[4]	1926.10	3023.60
5	Port3[3]	98.00	2661.25	44	Port3[2]	2066.30	2657.35
6	Port3[1]	98.00	2558.25	43	Port3[0]	2066.30	2554.35
7	Port2[7]	98.00	2455.25	42	Port2[6]	2066.30	2451.35
8	Port2[5]	98.00	2352.25	41	Port2[4]	2066.30	2348.35
9	Port2[3]	98.00	2249.25	40	Port2[2]	2066.30	2245.35
10	Port2[1]	98.00	2146.25	39	Port2[0]	2066.30	2142.35
11	Por1[7]	98.00	1134.25	38	Port1[6]	2066.30	1130.35
12	Por1[5]	98.00	1031.25	37	Port1[4]	2066.30	1027.35
13	Por1[3]	98.00	928.25	36	Port1[2]	2066.30	924.35
14	Por1[1]	98.00	825.25	35	Port1[0]	2066.30	821.35
15	DAC7	98.00	721.05	34	DAC6	2066.30	719.55
16	DAC5	98.00	618.05	33	DAC4	2066.30	616.55
17	Port0[7]	98.00	516.25	32	Port0[6]	2066.30	512.35
18	Port0[5]	98.00	413.25	31	Port0[4]	2066.30	409.35
19	Port0[3]	306.30	98.00	30	Port0[2]	1858.00	98.00
20	Port0[1]	442.15	98.00	29	Port0[0]	1718.30	98.00
21	DAC3	593.40	98.00	28	DAC2	1618.50	98.00
22	DAC1	696.40	98.00	27	DAC0	1513.50	98.00
23	V _{PP}	824.25	98.00	26	XtalOut	1301.90	98.00
24	V _{SS}	949.65	98.00	25	XtalIn	1160.50	98.00



Programming Model

14-bit Program Counter (PC)

The 14-bit Program Counter (PC) allows access for up to 8 kilobytes of EPROM using the CY7C63413C/513C/613C architecture. The program counter is cleared during reset, such that the first instruction executed after a reset is at address 0x0000. This is typically a jump instruction to a reset handler that initializes the application.

The lower eight bits of the program counter are incremented as instructions are loaded and executed. The upper six bits of the program counter are incremented by executing an XPAGE instruction. As a result, the last instruction executed within a 256-byte “page” of sequential code should be an XPAGE instruction. The assembler directive “XPAGEON” will cause the assembler to insert XPAGE instructions automatically. As instructions can be either one or two bytes long, the assembler may occasionally need to insert a NOP followed by an XPAGE for correct execution.

The program counter of the next instruction to be executed, carry flag, and zero flag are saved as two bytes on the program stack during an interrupt acknowledge or a CALL instruction. The program counter, carry flag, and zero flag are restored from the program stack only during a RETI instruction.

Please note the program counter cannot be accessed directly by the firmware. The program stack can be examined by reading SRAM from location 0x00 and up.

8-bit Accumulator (A)

The accumulator is the general purpose, do everything register in the architecture where results are usually calculated.

8-bit Index Register (X)

The index register “X” is available to the firmware as an auxiliary accumulator. The X register also allows the processor to perform indexed operations by loading an index value into X.

8-bit Program Stack Pointer (PSP)

During a reset, the Program Stack Pointer (PSP) is set to zero. This means the program “stack” starts at RAM address 0x00 and “grows” upward from there. Note the program stack pointer is directly addressable under firmware control, using the MOV

PSP,A instruction. The PSP supports interrupt service under hardware control and CALL, RET, and RETI instructions under firmware control.

During an interrupt acknowledge, interrupts are disabled and the 14-bit program counter, carry flag, and zero flag are written as two bytes of data memory. The first byte is stored in the memory addressed by the program stack pointer, then the PSP is incremented. The second byte is stored in memory addressed by the program stack pointer and the PSP is incremented again. The net effect is to store the program counter and flags on the program “stack” and increment the program stack pointer by two.

The Return From Interrupt (RETI) instruction decrements the program stack pointer, then restores the second byte from memory addressed by the PSP. The program stack pointer is decremented again and the first byte is restored from memory addressed by the PSP. After the program counter and flags have been restored from stack, the interrupts are enabled. The effect is to restore the program counter and flags from the program stack, decrement the program stack pointer by two, and re-enable interrupts.

The Call Subroutine (CALL) instruction stores the program counter and flags on the program stack and increments the PSP by two.

The Return From Subroutine (RET) instruction restores the program counter, but not the flags, from program stack and decrements the PSP by two.

8-bit Data Stack Pointer (DSP)

The Data Stack Pointer (DSP) supports PUSH and POP instructions that use the data stack for temporary storage. A PUSH instruction will pre-decrement the DSP, then write data to the memory location addressed by the DSP. A POP instruction will read data from the memory location addressed by the DSP, then post-increment the DSP.

During a reset, the Data Stack Pointer will be set to zero. A PUSH instruction when DSP equal zero will write data at the top of the data RAM (address 0xFF). This would write data to the memory area reserved for a FIFO for USB endpoint 0. In non-USB applications, this works fine and is not a problem. For USB applications, it is strongly recommended that the DSP is loaded after reset just below the USB DMA buffers.



Address Modes

The CY7C63413C/513C/613C microcontrollers support three addressing modes for instructions that require data operands: data, direct, and indexed.

Data

The “Data” address mode refers to a data operand that is actually a constant encoded in the instruction. As an example, consider the instruction that loads A with the constant 0xE8:

- MOV A,0E8h

This instruction will require two bytes of code where the first byte identifies the “MOV A” instruction with a data operand as the second byte. The second byte of the instruction will be the constant “0xE8”. A constant may be referred to by name if a prior “EQU” statement assigns the constant value to the name. For example, the following code is equivalent to the example shown above:

- DSPINIT: EQU 0E8h

- MOV A,DSPINIT

Direct

“Direct” address mode is used when the data operand is a variable stored in SRAM. In that case, the one byte address of the variable is encoded in the instruction. As an example,

consider an instruction that loads A with the contents of memory address location 0x10:

- MOV A, [10h]

In normal usage, variable names are assigned to variable addresses using “EQU” statements to improve the readability of the assembler source code. As an example, the following code is equivalent to the example shown above:

- buttons: EQU 10h

- MOV A,[buttons]

Indexed

“Indexed” address mode allows the firmware to manipulate arrays of data stored in SRAM. The address of the data operand is the sum of a constant encoded in the instruction and the contents of the “X” register. In normal usage, the constant will be the “base” address of an array of data and the X register will contain an index that indicates which element of the array is actually addressed:

- array: EQU 10h

- MOV X,3

- MOV A,[x+array]

This would have the effect of loading A with the fourth element of the SRAM “array” that begins at address 0x10. The fourth element would be at address 0x13.



Instruction Set Summary

MNEMONIC	operand	opcode	cycles	MNEMONIC	operand	opcode	cycles
HALT		00	7	NOP		20	4
ADD A,expr	data	01	4	INC A	acc	21	4
ADD A,[expr]	direct	02	6	INC X	x	22	4
ADD A,[X+expr]	index	03	7	INC [expr]	direct	23	7
ADC A,expr	data	04	4	INC [X+expr]	index	24	8
ADC A,[expr]	direct	05	6	DEC A	acc	25	4
ADC A,[X+expr]	index	06	7	DEC X	x	26	4
SUB A,expr	data	07	4	DEC [expr]	direct	27	7
SUB A,[expr]	direct	08	6	DEC [X+expr]	index	28	8
SUB A,[X+expr]	index	09	7	IORD expr	address	29	5
SBB A,expr	data	0A	4	IOWR expr	address	2A	5
SBB A,[expr]	direct	0B	6	POP A		2B	4
SBB A,[X+expr]	index	0C	7	POP X		2C	4
OR A,expr	data	0D	4	PUSH A		2D	5
OR A,[expr]	direct	0E	6	PUSH X		2E	5
OR A,[X+expr]	index	0F	7	SWAP A,X		2F	5
AND A,expr	data	10	4	SWAP A,DSP		30	5
AND A,[expr]	direct	11	6	MOV [expr],A	direct	31	5
AND A,[X+expr]	index	12	7	MOV [X+expr],A	index	32	6
XOR A,expr	data	13	4	OR [expr],A	direct	33	7
XOR A,[expr]	direct	14	6	OR [X+expr],A	index	34	8
XOR A,[X+expr]	index	15	7	AND [expr],A	direct	35	7
CMP A,expr	data	16	5	AND [X+expr],A	index	36	8
CMP A,[expr]	direct	17	7	XOR [expr],A	direct	37	7
CMP A,[X+expr]	index	18	8	XOR [X+expr],A	index	38	8
MOV A,expr	data	19	4	IOWX [X+expr]	index	39	6
MOV A,[expr]	direct	1A	5	CPL		3A	4
MOV A,[X+expr]	index	1B	6	ASL		3B	4
MOV X,expr	data	1C	4	ASR		3C	4
MOV X,[expr]	direct	1D	5	RLC		3D	4
<i>reserved</i>		1E		RRC		3E	4
XPAGE		1F	4	RET		3F	8
MOV A,X		40	4	DI		70	4
MOV X,A		41	4	EI		72	4
MOV PSP,A		60	4	RETI		73	8
CALL	addr	50-5F	10				
JMP	addr	80-8F	5	JC	addr	C0-CF	5
CALL	addr	90-9F	10	JNC	addr	D0-DF	5
JZ	addr	A0-AF	5	JACC	addr	E0-EF	7
JNZ	addr	B0-BF	5	INDEX	addr	F0-FF	14



Memory Organization

Program Memory Organization

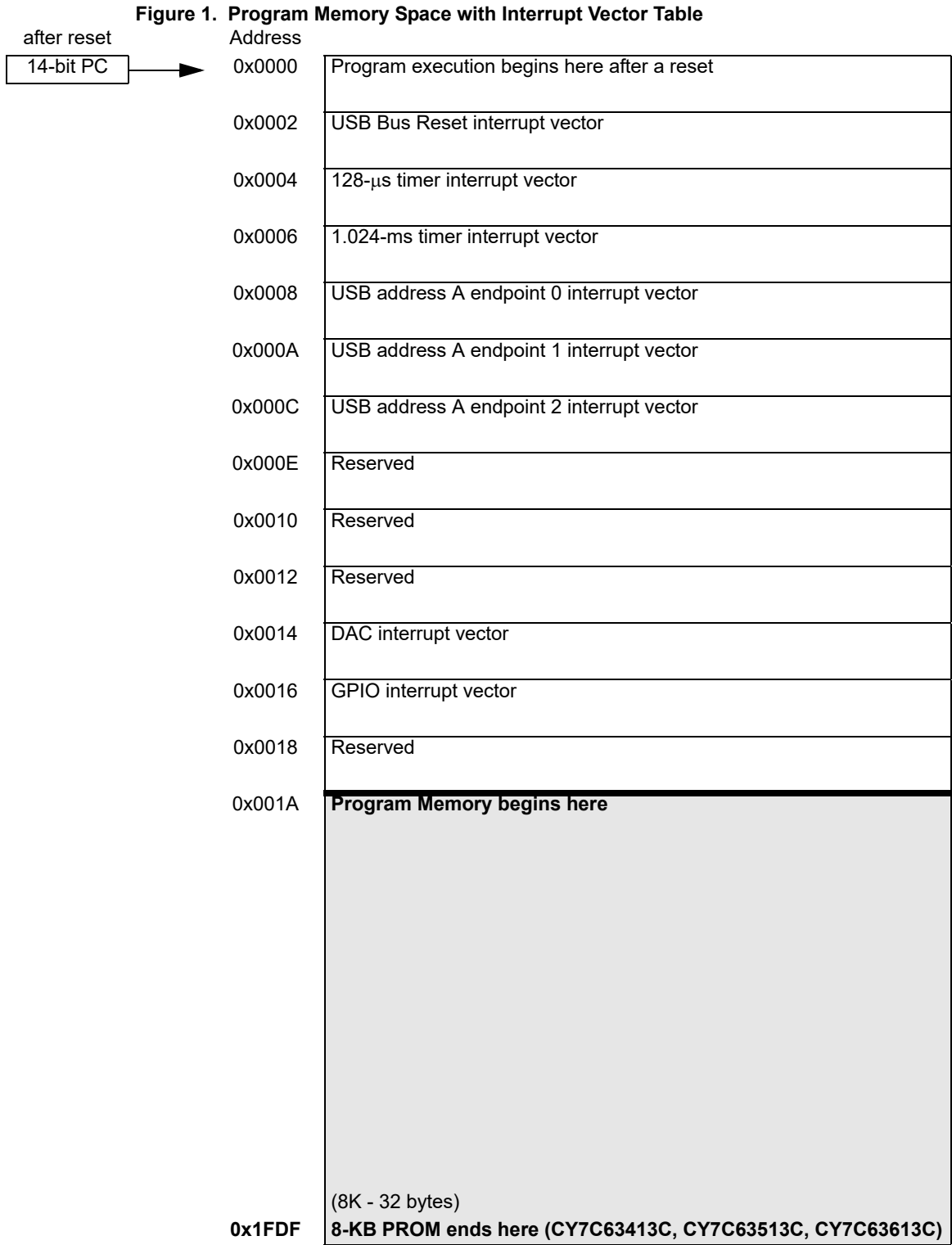



Data Memory Organization

The CY7C63413C/513C/613C microcontrollers provide 256 bytes of data RAM. In normal usage, the SRAM is partitioned into four areas: program stack, data stack, user variables and USB endpoint FIFOs as shown below:

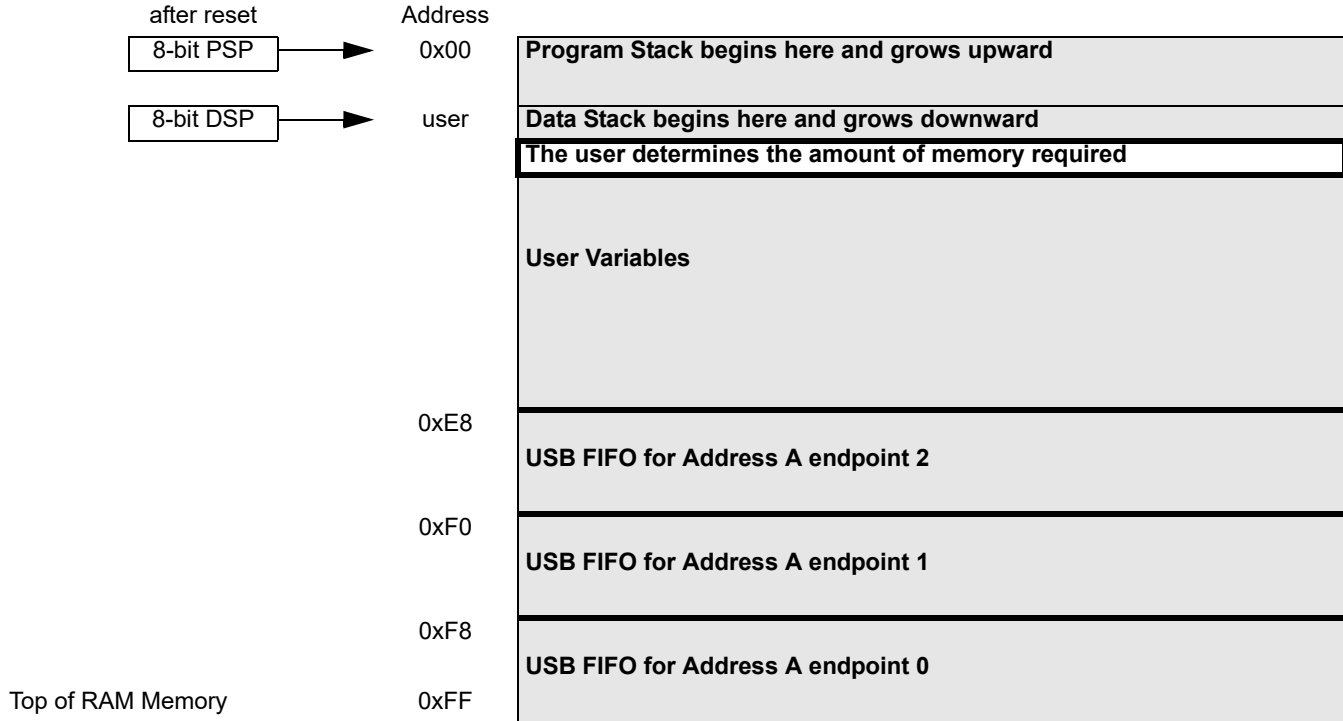



I/O Register Summary

I/O registers are accessed via the I/O Read (IORD) and I/O Write (IOWR, IOWX) instructions. IORD reads the selected port into the accumulator. IOWR writes data from the accumulator to the

selected port. Indexed I/O Write (IOWX) adds the contents of X to the address in the instruction to form the port address and writes data from the accumulator to the specified port. Note that specifying address 0 (e.g., IOWX 0h) means the I/O port is selected solely by the contents of X.

Table 2. I/O Register Summary

Register Name	I/O Address	Read/Write	Function
Port 0 Data	0x00	R/W	GPIO Port 0
Port 1 Data	0x01	R/W	GPIO Port 1
Port 2 Data	0x02	R/W	GPIO Port 2
Port 3 Data	0x03	R/W	GPIO Port 3
Port 0 Interrupt Enable	0x04	W	Interrupt enable for pins in Port 0
Port 1 Interrupt Enable	0x05	W	Interrupt enable for pins in Port 1
Port 2 Interrupt Enable	0x06	W	Interrupt enable for pins in Port 2
Port 3 Interrupt Enable	0x07	W	Interrupt enable for pins in Port 3
GPIO Configuration	0x08	R/W	GPIO Ports Configurations
USB Device Address A	0x10	R/W	USB Device Address A
EP A0 Counter Register	0x11	R/W	USB Address A, Endpoint 0 counter register
EP A0 Mode Register	0x12	R/W	USB Address A, Endpoint 0 configuration register
EP A1 Counter Register	0x13	R/W	USB Address A, Endpoint 1 counter register
EP A1 Mode Register	0x14	R/C	USB Address A, Endpoint 1 configuration register
EP A2 Counter Register	0x15	R/W	USB Address A, Endpoint 2 counter register
EP A2 Mode Register	0x16	R/C	USB Address A, Endpoint 2 configuration register
USB Status & Control	0x1F	R/W	USB upstream port traffic status and control register
Global Interrupt Enable	0x20	R/W	Global interrupt enable register
Endpoint Interrupt Enable	0x21	R/W	USB endpoint interrupt enables
Timer (LSB)	0x24	R	Lower eight bits of free-running timer (1 MHz)
Timer (MSB)	0x25	R	Upper four bits of free-running timer that are latched when the lower eight bits are read.
WDR Clear	0x26	W	Watch Dog Reset clear
DAC Data	0x30	R/W	DAC I/O ^[2]
DAC Interrupt Enable	0x31	W	Interrupt enable for each DAC pin
DAC Interrupt Polarity	0x32	W	Interrupt polarity for each DAC pin
DAC Isink	0x38-0x3F	W	One four bit sink current register for each DAC pin
Processor Status & Control	0xFF	R/W	Microprocessor status and control

Note

2. DAC I/O Port not bonded out on CY7C63613C. See note on page 12 for firmware code needed for unused GPIO pins.

Figure 2. Clock Oscillator On-chip Circuit

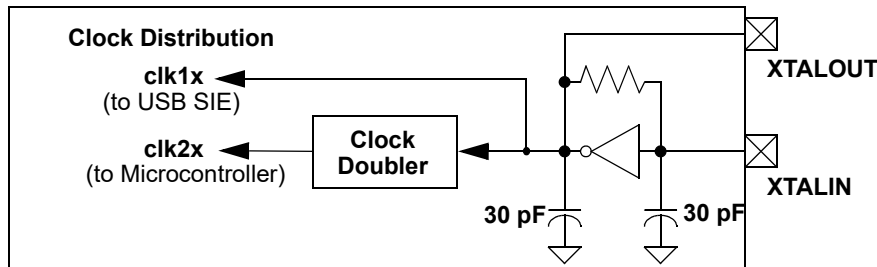

Clocking

The XTAL_{IN} and XTAL_{OUT} are the clock pins to the microcontroller. The user can connect a low-cost ceramic resonator or an external oscillator can be connected to these pins to provide a reference frequency for the internal clock distribution and clock doubler.

An external 6-MHz clock can be applied to the XTAL_{IN} pin if the XTAL_{OUT} pin is left open. Please note that grounding the XTAL_{OUT} pin is not permissible as the internal clock is effectively shorted to ground.

Reset

The USB Controller supports three types of resets. All registers are restored to their default states during a reset. The USB Device Addresses are set to 0 and all interrupts are disabled. In addition, the program stack pointer (PSP) and data stack pointer (DSP) are set to 0x00. For USB applications, the firmware should set the DSP below 0xE8 to avoid a memory conflict with RAM dedicated to USB FIFOs. The assembly instructions to do this are shown below:

```
Mov A, E8h ; Move 0xE8 hex into Accumulator
Swap A,dsp ; Swap accumulator value into dsp register
```

The three reset types are:

1. Power-On Reset (POR)
2. Watch Dog Reset (WDR)
3. USB Bus Reset (non hardware reset)

The occurrence of a reset is recorded in the Processor Status and Control Register located at I/O address 0xFF. Bits 4, 5, and 6 are used to record the occurrence of POR, USB Reset, and WDR respectively. The firmware can interrogate these bits to determine the cause of a reset.

The microcontroller begins execution from ROM address 0x0000 after a POR or WDR reset. Although this looks like interrupt vector 0, there is an important difference. Reset processing does NOT push the program counter, carry flag, and zero flag onto program stack. That means the reset handler in firmware should initialize the hardware and begin executing the "main" loop of code. Attempting to execute either a RET or RETI in the reset handler will cause unpredictable execution results.

Power-On Reset (POR)

Power-On Reset (POR) occurs every time the V_{CC} voltage to the device ramps from 0V to an internally defined trip voltage (V_{rst})

of approximately 1/2 full supply voltage. In addition to the normal reset initialization noted under "Reset," bit 4 (PORS) of the Processor Status and Control Register is set to "1" to indicate to the firmware that a Power-On Reset occurred. The POR event forces the GPIO ports into input mode (high impedance), and the state of Port 3 bit 7 is used to control how the part will respond after the POR releases.

If Port 3 bit 7 is HIGH (pulled to V_{CC}) and the USB I/O are at the idle state (DM HIGH and DP LOW) the part will go into a semi-permanent power down/suspend mode, waiting for the USB I/O to go to one of Bus Reset, K (resume) or SE0. If Port 3 bit 7 is still HIGH when the part comes out of suspend, then a 128-μs timer starts, delaying CPU operation until the ceramic resonator has stabilized.

If Port 3 bit 7 was LOW (pulled to V_{SS}) the part will start a 96-ms timer, delaying CPU operation until V_{CC} has stabilized, then continuing to run as reset.

Firmware should clear the POR Status (PORS) bit in register 0xFF before going into suspend as this status bit selects the 128-μs or 96-ms start-up timer value as follows: IF Port 3 bit 7 is HIGH then 128-μs is always used; ELSE if PORS is HIGH then 96-ms is used; ELSE 128-μs is used.

Watch Dog Reset (WDR)

The Watch Dog Timer Reset (WDR) occurs when the Most Significant Bit (MSB) of the 2-bit Watch Dog Timer Register transitions from LOW to HIGH. In addition to the normal reset initialization noted under "Reset", bit 6 of the Processor Status and Control Register is set to "1" to indicate to the firmware that a Watch Dog Reset occurred.

The Watch Dog Timer is a 2-bit timer clocked by a 4.096-ms clock (bit 11) from the free-running timer. Writing any value to the write-only Watch Dog Clear I/O port (0x26) will clear the Watch Dog Timer.

In some applications, the Watch Dog Timer may be cleared in the 1.024-ms timer interrupt service routine. If the 1.024-ms timer interrupt service routine does not get executed for 8.192 ms or more, a Watch Dog Timer Reset will occur. A Watch Dog Timer Reset lasts for 2.048 ms after which the microcontroller begins execution at ROM address 0x0000. The USB transmitter is disabled by a Watch Dog Reset because the USB Device Address Register is cleared. Otherwise, the USB Controller would respond to all address 0 transactions. The USB transmitter remains disabled until the MSB of the USB address register is set.



General Purpose I/O Ports

Ports 0 to 2 provide 24 GPI/O pins that can be read or written. Each port (8 bits) can be configured as inputs with internal pull-ups, open drain outputs, or traditional CMOS outputs. Please note an open drain output is also a high-impedance (no pull-up) input. All of the I/O pins within a given port have the same configuration. Ports 0 to 2 are considered low current drive with typical current sink capability of 7 mA.

The internal pull-up resistors are typically 7 kΩ. Two factors govern the enabling and disabling of the internal pull-up

resistors: the port configuration selected in the GPI/O Configuration register and the state of the output data bit. If the GPI/O Configuration selected is “Resistive” and the output data bit is “1,” then the internal pull-up resistor is enabled for that GPI/O pin. Otherwise, Q1 is turned off and the 7-kΩ pull-up is disabled. Q2 is “ON” to sink current whenever the output data bit is written as a “0”. Q3 provides “HIGH” source current when the GPI/O port is configured for CMOS outputs and the output data bit is written as a “1”. Q2 and Q3 are sized to sink and source, respectively, roughly the same amount of current to support traditional CMOS outputs with symmetric drive.

Figure 3. Block Diagram of a GPIO Line

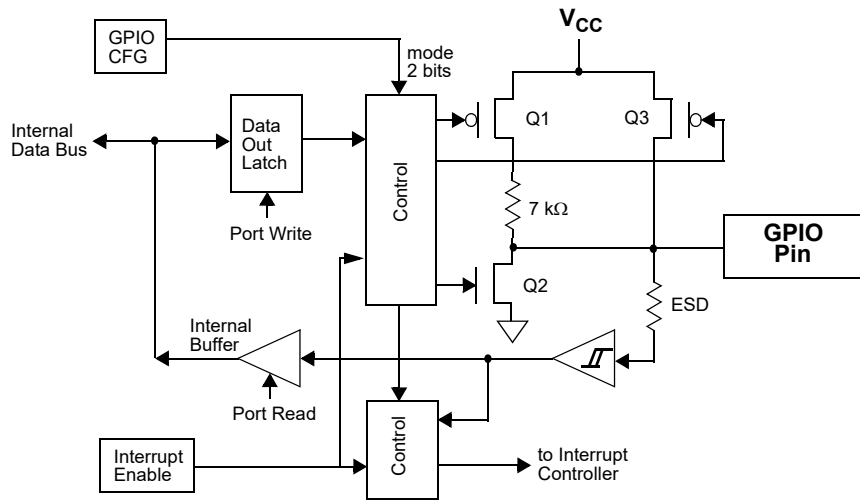

Table 3. Port 0 Data

Addr: 0x00		Port 0 Data					
P0[7]	P0[6]	P0[5]	P0[4]	P0[3]	P0[2]	P0[1]	P0[0]
R/W	R/W	R/W	R/W	R/W	R/W	R/W	R/W

Table 4. Port 1 Data

Addr: 0x01		Port 1 Data					
P1[7]	P1[6]	P1[5]	P1[4]	P1[3]	P1[2]	P1[1]	P1[0]
R/W	R/W	R/W	R/W	R/W	R/W	R/W	R/W



Figure 4. Watch Dog Reset (WDR)

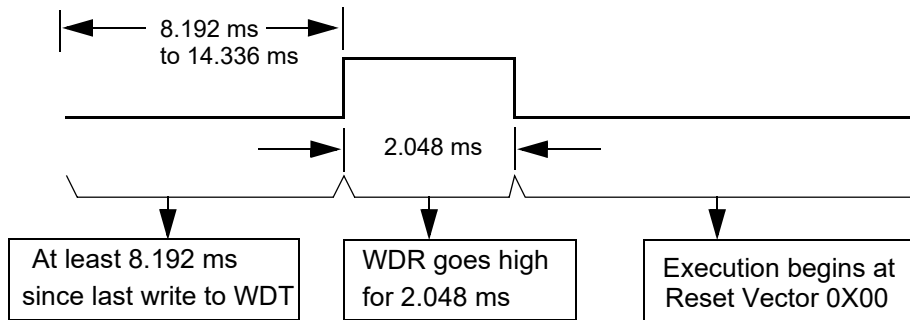

Table 5. Port 2 Data

Addr: 0x02		Port 2 Data					
P2[7]	P2[6]	P2[5]	P2[4]	P2[3]	P2[2]	P2[1]	P2[0]
R/W	R/W	R/W	R/W	R/W	R/W	R/W	R/W

Table 6. Port 3 Data

Addr: 0x03		Port 3 Data					
P3[7]	P3[6]	P3[5]	P3[4]	P3[3]	P3[2]	P3[1]	P3[0]
R/W	R/W	R/W	R/W	R/W	R/W	R/W	R/W

Addr: 0x30		DAC Port Data					
Low current outputs 0.2 mA to 1.0 mA typical						High current outputs 3.2 mA to 16 mA typical	
DAC[7]	DAC[6]	DAC[5]	DAC[4]	DAC[3]	DAC[2]	DAC[1]	DAC[0]
R/W	R/W	R/W	R/W	R/W	R/W	R/W	R/W

Port 3 has eight GPIO pins. Port 3 (8 bits) can be configured as inputs with internal pull-ups, open drain outputs, or traditional CMOS outputs. An open drain output is also a high-impedance input. Port 3 offers high current drive with a typical current sink capability of 12 mA. The internal pull-up resistors are typically 7 kΩ.

Note Special care should be exercised with any unused GPIO data bits. An unused GPIO data bit, either a pin on the chip or a port bit that is not bonded on a particular package, must not be left floating when the device enters the suspend state. If a GPIO data bit is left floating, the leakage current caused by the floating bit may violate the suspend current limitation specified by the USB Specification. If a '1' is written to the unused data bit and the port is configured with open drain outputs, the unused data bit will be in an indeterminate state. Therefore, if an unused port bit is programmed in open-drain mode, it must be written with a '0.' Notice that the CY7C63613C will always require that data bits P1[7:4], P2[7:0], P3[3:0] and DAC[7:0] be written with a '0'.

During reset, all of the bits in the GPIO to a default configuration of Open Drain output, positive interrupt polarity for all GPIO ports.

GPIO Interrupt Enable Ports

During a reset, GPIO interrupts are disabled by clearing all of the GPIO interrupt enable ports. Writing a "1" to a GPIO Interrupt Enable bit enables GPIO interrupts from the corresponding input pin.

GPIO Configuration Port

Every GPIO port can be programmed as inputs with internal pull-ups, open drain outputs, and traditional CMOS outputs. In addition, the interrupt polarity for each port can be programmed. With positive interrupt polarity, a rising edge ("0" to "1") on an input pin causes an interrupt. With negative polarity, a falling edge ("1" to "0") on an input pin causes an interrupt. As shown in the table below, when a GPIO port is configured with CMOS outputs, interrupts from that port are disabled. The GPIO Configuration Port register provides two bits per port to program these features. The possible port configurations are as shown in Table 11.



Table 7. Port 0 Interrupt Enable

Addr: 0x04		Port 0 Interrupt Enable					
P0[7]	P0[6]	P0[5]	P0[4]	P0[3]	P0[2]	P0[1]	P0[0]
W	W	W	W	W	W	W	W

Table 8. Port 1 Interrupt Enable

Addr: 0x05		Port 1 Interrupt Enable					
P1[7]	P1[6]	P1[5]	P1[4]	P1[3]	P1[2]	P1[1]	P1[0]
W	W	W	W	W	W	W	W

Table 9. Port 2 Interrupt Enable

Addr: 0x06		Port 2 Interrupt Enable					
P2[7]	P2[6]	P2[5]	P2[4]	P2[3]	P2[2]	P2[1]	P2[0]
W	W	W	W	W	W	W	W

Table 10. Port 3 Interrupt Enable

Addr: 0x07		Port 3 Interrupt Enable					
P3[7]	P3[6]	P3[5]	P3[4]	P3[3]	P3[2]	P3[1]	P3[0]
W	W	W	W	W	W	W	W

Table 11. Possible Port Configurations

Port Configuration bits	Pin Interrupt Bit	Driver Mode	Interrupt Polarity
11	X	Resistive	–
10	0	CMOS Output	disabled
10	1	Open Drain	disabled
01	X	Open Drain	–
00	X	Open Drain	+ (default)

In “Resistive” mode, a 7-kΩ pull-up resistor is conditionally enabled for all pins of a GPIO port. The resistor is enabled for any pin that has been written as a “1”. The resistor is disabled on any pin that has been written as a “0”. An I/O pin will be driven high through a 7-kΩ pull-up resistor when a “1” has been written to the pin. Or the output pin will be driven LOW, with the pull-up disabled, when a “0” has been written to the pin. An I/O pin that has been written as a “1” can be used as an input pin with an integrated 7-kΩ pull-up resistor. Resistive mode selects a negative (falling edge) interrupt polarity on all pins that have the GPIO interrupt enabled.

In “CMOS” mode, all pins of the GPIO port are outputs that are actively driven. The current source and sink capacity are roughly the same (symmetric output drive). A CMOS port is not a possible source for interrupts.

A port configured in CMOS mode has interrupt generation disabled, yet the interrupt mask bits serve to control port

direction. If a port’s associated Interrupt Mask bits are cleared, those port bits are strictly outputs. If the Interrupt Mask bits are set then those bits will be open drain inputs. As open drain inputs, if their data output values are ‘1’ those port pins will be CMOS inputs (HIGH Z output).

In “Open Drain” mode the internal pull-up resistor and CMOS driver (HIGH) are both disabled. An I/O pin that has been written as a “1” can be used as either a high-impedance input or a three-state output. An I/O pin that has been written as a “0” will drive the output LOW. The interrupt polarity for an open drain GPIO port can be selected as either positive (rising edge) or negative (falling edge).

During reset, all of the bits in the GPIO Configuration Register are written with “0”. This selects the default configuration: Open Drain output, positive interrupt polarity for all GPIO ports.

Table 12. GPIO Configuration Register

Addr: 0x08		GPIO Configuration Register					
7	6	5	4	3	2	1	0
Port 3 Config Bit 1	Port 3 Config Bit 0	Port 2 Config Bit 1	Port 2 Config Bit 0	Port 1 Config Bit 1	Port 1 Config Bit 0	Port 0 Config Bit 1	Port 0 Config Bit 0
W	W	W	W	W	W	W	W

DAC Port

Figure 5. Block Diagram of DAC Port

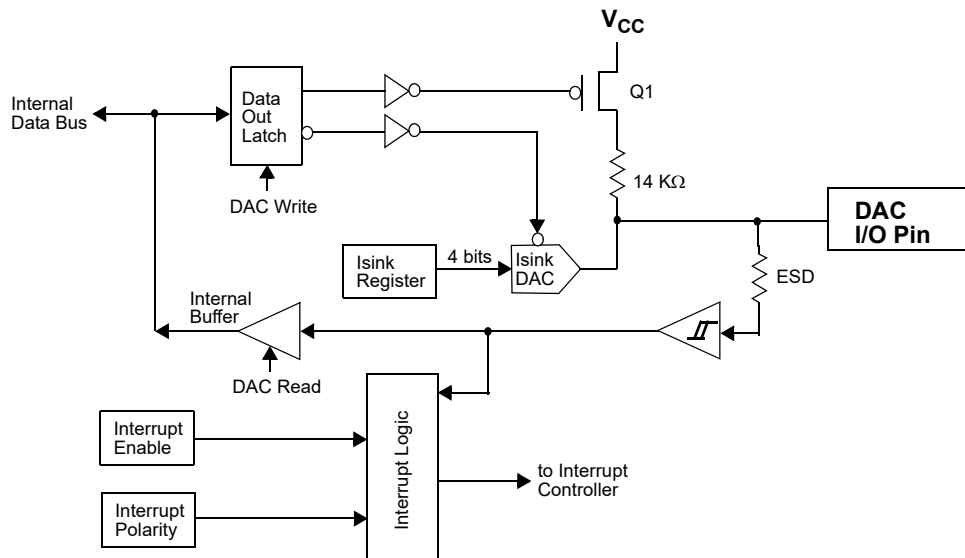

Table 13. DAC Port Data

Addr: 0x30		DAC Port Data					
Low current outputs 0.2 mA to 1.0 mA typical				High current outputs 3.2 mA to 16 mA typical			
DAC[7]	DAC[6]	DAC[5]	DAC[4]	DAC[3]	DAC[2]	DAC[1]	DAC[0]
R/W	R/W	R/W	R/W	R/W	R/W	R/W	R/W

The DAC port provides the CY7C63513C with 8 programmable current sink I/O pins. Writing a “1” to a DAC I/O pin disables the output current sink (Isink DAC) and drives the I/O pin HIGH through an integrated 14 Kohm resistor. When a “0” is written to a DAC I/O pin, the Isink DAC is enabled and the pull-up resistor is disabled. A “0” output will cause the Isink DAC to sink current to drive the output LOW. The amount of sink current for the DAC I/O pin is programmable over 16 values based on the contents of the DAC Isink Register for that output pin. DAC[1:0] are the two high current outputs that are programmable from a minimum of 3.2 mA to a maximum of 16 mA (typical). DAC[7:2] are low current outputs that are programmable from a minimum of 0.2 mA to a maximum of 1.0 mA (typical).

When a DAC I/O bit is written as a “1”, the I/O pin is either an output pulled high through the 14 Kohm resistor or an input with

an internal 14 Kohm pull-up resistor. All DAC port data bits are set to “1” during reset.

DAC Port Interrupts

A DAC port interrupt can be enabled/disabled for each pin individually. The DAC Port Interrupt Enable register provides this feature with an interrupt mask bit for each DAC I/O pin. Writing a “1” to a bit in this register enables interrupts from the corresponding bit position. Writing a “0” to a bit in the DAC Port Interrupt Enable register disables interrupts from the corresponding bit position. All of the DAC Port Interrupt Enable register bits are cleared to “0” during a reset.

As an additional benefit, the interrupt polarity for each DAC pin is programmable with the DAC Port Interrupt Polarity register.



Writing a “0” to a bit selects negative polarity (falling edge) that will cause an interrupt (if enabled) if a falling edge transition occurs on the corresponding input pin. Writing a “1” to a bit in this register selects positive polarity (rising edge) that will cause an interrupt (if enabled) if a rising edge transition occurs on the corresponding input pin. All of the DAC Port Interrupt Polarity register bits are cleared during a reset.

DAC Isink Registers

Each DAC I/O pin has an associated DAC Isink register to program the output sink current when the output is driven LOW. The first Isink register (0x38) controls the current for DAC[0], the second (0x39) for DAC[1], and so on until the Isink register at 0x3F controls the current to DAC[7].

Table 14. DAC Port Interrupt Enable

Addr: 0x31		DAC Port Interrupt Enable					
DAC[7]	DAC[6]	DAC[5]	DAC[4]	DAC[3]	DAC[2]	DAC[1]	DAC[0]
W	W	W	W	W	W	W	W

Table 15. DAC Port Interrupt Polarity

Addr: 0x32		DAC Port Interrupt Polarity					
DAC[7]	DAC[6]	DAC[5]	DAC[4]	DAC[3]	DAC[2]	DAC[1]	DAC[0]
W	W	W	W	W	W	W	W

Table 16. DAC Port Isink

Addr: 0x38-0x3F		DAC Port Interrupt Polarity					
Reserved				Isink Value			
				Isink[3]	Isink[2]	Isink[1]	Isink[0]
				W	W	W	W



USB Serial Interface Engine (SIE)

The SIE allows the microcontroller to communicate with the USB host. The SIE simplifies the interface between the microcontroller and USB by incorporating hardware that handles the following USB bus activity independently of the microcontroller:

- Bit stuffing/unstuffing
- Checksum generation/checking
- ACK/NAK
- Token type identification
- Address checking

Firmware is required to handle the rest of the USB interface with the following tasks:

- Coordinate enumeration by responding to set-up packets
- Fill and empty the FIFOs
- Suspend/Resume coordination
- Verify and select Data toggle values

USB Enumeration

The enumeration sequence is shown below:

1. The host computer sends a **Setup** packet followed by a **Data** packet to USB address 0 requesting the Device descriptor.
2. The USB Controller decodes the request and retrieves its Device descriptor from the program memory space.
3. The host computer performs a control read sequence and the USB Controller responds by sending the Device descriptor over the USB bus.
4. After receiving the descriptor, the host computer sends a **Setup** packet followed by a **Data** packet to address 0 assigning a new USB address to the device.
5. The USB Controller stores the new address in its USB Device Address Register after the no-data control sequence is complete.

6. The host sends a request for the Device descriptor using the new USB address.
7. The USB Controller decodes the request and retrieves the Device descriptor from the program memory.
8. The host performs a control read sequence and the USB Controller responds by sending its Device descriptor over the USB bus.
9. The host generates control reads to the USB Controller to request the Configuration and Report descriptors.
10. The USB Controller retrieves the descriptors from its program space and returns the data to the host over the USB.

PS/2 Operation

PS/2 operation is possible with the CY7C63413C/513C/613C series through the use of firmware and several operating modes. The first enabling feature:

1. USB Bus reset on D+ and D- is an interrupt that can be disabled;
2. USB traffic can be disabled via bit 7 of the USB register;
3. D+ and D- can be monitored and driven via firmware as independent port bits.

Bits 5 and 4 of the Upstream Status and Control register are directly connected to the D+ and D- USB pins of the CY7C63413C/513C/613C. These pins constantly monitor the levels of these signals with CMOS input thresholds. Firmware can poll and decode these signals as PS/2 clock and data.

Bits [2:0] defaults to '000' at reset which allows the USB SIE to control output on D+ and D-. Firmware can override the SIE and directly control the state of these pins via these 3 control bits. Since PS/2 is an open drain signaling protocol, these modes allow all 4 PS/2 states to be generated on the D+ and D- pins

USB Port Status and Control

USB status and control is regulated by the USB Status and Control Register located at I/O address 0x1F as shown in [Figure 17](#). This is a read/write register. All reserved bits must be written to zero. All bits in the register are cleared during reset.

Table 17. USB Status and Control Register

Addr:0x1F		USB Status and Control Register					
7	6	5	4	3	2	1	0
Reserved	Reserved	D+	D-	Bus Activity	Control Bit 2	Control Bit 1	Control Bit 0
		R	R	R/W	R/W	R/W	R/W



The Bus Activity bit is a “sticky” bit that indicates if any non-idle USB event has occurred on the USB bus. The user firmware should check and clear this bit periodically to detect any loss of bus activity. Writing a “0” to the Bus Activity bit clears it while writing a “1” preserves the current value. In other words, the firmware can clear the Bus Activity bit, but only the SIE can set it. The 1.024-ms timer interrupt service routine is normally used to check and clear the Bus Activity bit. The following table shows how the control bits are encoded for this register.

Control Bits	Control Action
000	Not forcing (SIE controls driver)
001	Force K (D+ HIGH, D- LOW)
010	Force J (D+ LOW, D- HIGH)
011	Force SE0 (D+ LOW, D- LOW)
100	Force SE0 (D- LOW, D+ LOW)
101	Force D- LOW, D+ HiZ
110	Force D- HiZ, D+ LOW
111	Force D- HiZ, D+ HiZ

USB Device

USB Device Address A includes three endpoints: EPA0, EPA1, and EPA2. End Point 0 (EPA0) allows the USB host to recognize, set up, and control the device. In particular, EPA0 is used to receive and transmit control (including set-up) packets.

USB Ports

The USB Controller provides one USB device address with three endpoints. The USB Device Address Register contents are

Table 18. USB Device Address Register

Addr:0x10		USB Device Address Register					
Device Address Enable	Device Address Bit 6	Device Address Bit 5	Device Address Bit 4	Device Address Bit 3	Device Address Bit 2	Device Address Bit 1	Device Address Bit 0
R/W	R/W	R/W	R/W	R/W	R/W	R/W	R/W

Table 19. USB Device EPA0, Mode Register

Addr:0x12		USB Device EPA0, Mode Register					
Endpoint 0 Set-up Received	Endpoint 0 In Received	Endpoint 0 Out Received	Acknowledge	Mode Bit 3	Mode Bit 2	Mode Bit 1	Mode Bit 0
R/W	R/W	R/W	R/W	R/W	R/W	R/W	R/W

Table 20. USB Device Endpoint Mode Register

Addr: 0x14, 0x16		USB Device Endpoint Mode Register					
Reserved	Reserved	Reserved	Acknowledge	Mode Bit 3	Mode Bit 2	Mode Bit 1	Mode Bit 0
R/W	R/W	R/W	R/W	R/W	R/W	R/W	R/W

cleared during a reset, setting the USB device address to zero and marking this address as disabled. [Figure 18](#) shows the format of the USB Address Register.

Bit 7 (Device Address Enable) in the USB Device Address Register must be set by firmware before the serial interface engine (SIE) will respond to USB traffic to this address. The USB Address in bits [6:0] must be set by firmware during the USB enumeration process to an address assigned by the USB host that does not equal zero. This register is cleared by a hardware reset or the USB bus reset.

Device Endpoints (3)

The USB controller communicates with the host using dedicated FIFOs, one per endpoint. Each endpoint FIFO is implemented as 8 bytes of dedicated SRAM. There are three endpoints defined for Device “A” that are labeled “EPA0,” “EPA1,” and EPA2”.

All USB devices are required to have an endpoint number 0 (EPA0) that is used to initialize and control the USB device. End Point 0 provides access to the device configuration information and allows generic USB status and control accesses. End Point 0 is bidirectional as the USB controller can both receive and transmit data.

The endpoint mode registers are cleared during reset. The EPA0 endpoint mode register uses the format shown in [Table 19](#).

Bits[7:5] in the endpoint 0 mode registers (EPA0) are “sticky” status bits that are set by the SIE to report the type of token that was most recently received. The sticky bits must be cleared by firmware as part of the USB processing.

The endpoint mode registers for EPA1 and EPA2 do not use bits [7:5] as shown in [Table 20](#).



The 'Acknowledge' bit is set whenever the SIE engages in a transaction that completes with an 'ACK' packet.

The 'set-up' PID status (bit[7]) is forced HIGH from the start of the data packet phase of the set-up transaction, until the start of the ACK packet returned by the SIE. The CPU is prevented from clearing this bit during this interval, and subsequently until the CPU first does an IORD to this endpoint 0 mode register.

Bits[6:0] of the endpoint 0 mode register are locked from CPU IOWR operations only if the SIE has updated one of these bits, which the SIE does only at the end of a packet transaction (set-up... Data... ACK, or Out... Data... ACK, or In... Data... ACK). The CPU can unlock these bits by doing a subsequent I/O read of this register.

Firmware must do an IORD after an IOWR to an endpoint 0 register to verify that the contents have changed and that the SIE has not updated these values.

While the 'set-up' bit is set, the CPU cannot write to the DMA buffers at memory locations 0xE0 through 0xE7 and 0xF8 through 0xFF. This prevents an incoming set-up transaction from conflicting with a previous In data buffer filling operation by firmware.

The mode bits (bits [3:0]) in an Endpoint Mode Register control how the endpoint responds to USB bus traffic. The mode bit encoding is shown in Section .

The format of the endpoint Device counter registers is shown in [Table 21](#).

Bits 0 to 3 indicate the number of data bytes to be transmitted during an IN packet, valid values are 0 to 8 inclusive. Data Valid bit 6 is used for OUT and set-up tokens only. Data 0/1 Toggle bit 7 selects the DATA packet's toggle state: 0 for DATA0, 1 for DATA1.

Table 21. USB Device Counter Registers

Addr: 0x11, 0x13, 0x15		USB Device Counter Registers					
Data 0/1 Toggle	Data Valid	Reserved	Reserved	Byte count Bit 3	Byte count Bit 2	Byte count Bit 1	Byte count Bit 0
R/W	R/W	R/W	R/W	R/W	R/W	R/W	R/W



12-bit Free-running Timer

The 12-bit timer provides two interrupts (128 μ s and 1.024 ms) and allows the firmware to directly time events that are up to 4 ms in duration. The lower 8 bits of the timer can be read directly by the firmware. Reading the lower 8 bits latches the upper 4 bits

into a temporary register. When the firmware reads the upper 4 bits of the timer, it is actually reading the count stored in the temporary register. The effect of this logic is to ensure a stable 12-bit timer value can be read, even when the two reads are separated in time.

Timer (LSB)

Table 22. Timer Register

Addr: 0x24		Timer Register (LSB)					
Timer Bit 7	Timer Bit 6	Timer Bit 5	Timer Bit 4	Timer Bit 3	Timer Bit 2	Timer Bit 1	Timer Bit 0
R	R	R	R	R	R	R	R

Timer (MSB)

Table 23. Timer Register

Addr: 0x25		Timer Register (MSB)					
Reserved	Reserved	Reserved	Reserved	Timer Bit 11	Timer Bit 10	Timer Bit 9	Timer Bit 8
				R	R	R	R

Figure 6. Timer Block Diagram

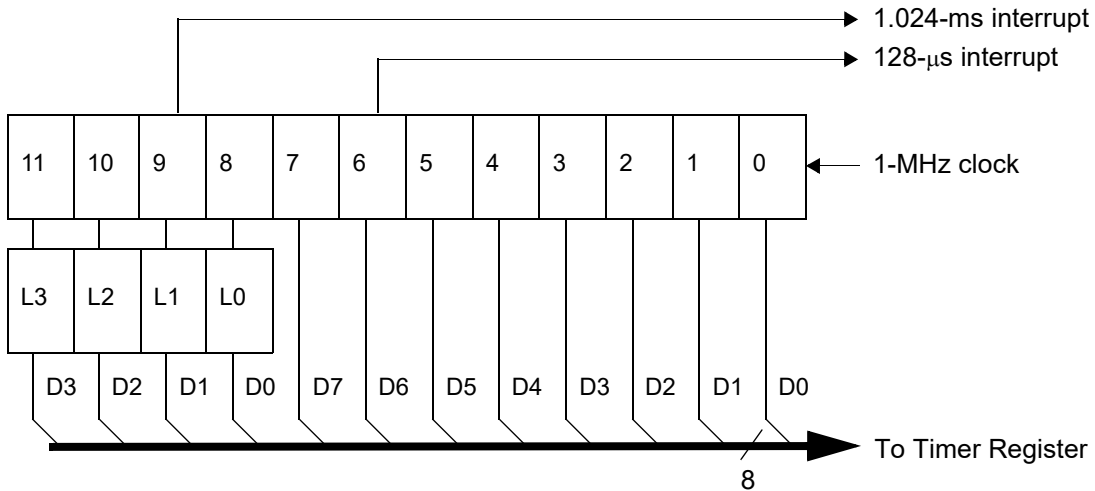



Processor Status and Control Register

Table 24. Processor Status and Control Register

Addr: 0xFF		Processor Status and Control Register				POR Default: 0x0101 WDC Reset: 0x41	
7	6	5	4	3	2	1	0
IRQ Pending	Watch Dog Reset	USB Bus Reset	Power-on Reset	Suspend, Wait for Interrupt	Interrupt Mask	Single Step	Run
R	R/W	R/W	R/W	R/W	R	R/W	R/W

The “Run” (bit 0) is manipulated by the HALT instruction. When Halt is executed, the processor clears the run bit and halts at the end of the current instruction. The processor remains halted until a reset (Power On or Watch Dog). Notice, when writing to the processor status and control register, the run bit should always be written as a “1.”

The “Single Step” (bit 1) is provided to support a hardware debugger. When single step is set, the processor will execute one instruction and halt (clear the run bit). This bit must be cleared for normal operation.

The “Interrupt Mask” (bit 2) shows whether interrupts are enabled or disabled. The firmware has no direct control over this bit as writing a zero or one to this bit position will have no effect on interrupts. Instructions DI, EI, and RETI manipulate the internal hardware that controls the state of the interrupt mask bit in the Processor Status and Control Register.

Writing a “1” to “Suspend, Wait for Interrupts” (bit 3) will halt the processor and cause the microcontroller to enter the “suspend” mode that significantly reduces power consumption. A pending interrupt or bus activity will cause the device to come out of suspend. After coming out of suspend, the device will resume firmware execution at the instruction following the IOWR which put the part into suspend. An IOWR that attempts to put the part into suspend will be ignored if either bus activity or an interrupt is pending.

The “Power-on Reset” (bit 4) is only set to “1” during a power on reset. The firmware can check bits 4 and 6 in the reset handler to determine whether a reset was caused by a Power On condition or a Watch Dog Timeout. PORS is used to determine suspend start-up timer value of 128 μ s or 96 ms.

The “USB Bus Reset” (bit 5) will occur when a USB bus reset is received. The USB Bus Reset is a singled-ended zero (SE0) that lasts more than 8 microseconds. An SE0 is defined as the condition in which both the D+ line and the D– line are LOW at the same time. When the SIE detects this condition, the USB Bus Reset bit is set in the Processor Status and Control register and an USB Bus Reset interrupt is generated. Please note this is an interrupt to the microcontroller and does not actually reset the processor.

The “Watch Dog Reset” (bit 6) is set during a reset initiated by the Watch Dog Timer. This indicates the Watch Dog Timer went for more than 8 ms between watch dog clears.

The “IRQ Pending” (bit 7) indicates one or more of the interrupts has been recognized as active. The interrupt acknowledge sequence should clear this bit until the next interrupt is detected.

During Power-on Reset, the Processor Status and Control Register is set to 00010001, which indicates a Power-on Reset (bit 4 set) has occurred and no interrupts are pending (bit 7 clear) yet.

During a Watch Dog Reset, the Processor Status and Control Register is set to 01000001, which indicates a Watch Dog Reset (bit 6 set) has occurred and no interrupts are pending (bit 7 clear) yet.

Interrupts

All interrupts are maskable by the Global Interrupt Enable Register and the USB End Point Interrupt Enable Register. Writing a “1” to a bit position enables the interrupt associated with that bit position. During a reset, the contents the Global Interrupt Enable Register and USB End Point Interrupt Enable Register are cleared, effectively disabling all interrupts.

Pending interrupt requests are recognized during the last clock cycle of the current instruction. When servicing an interrupt, the hardware will first disable all interrupts by clearing the Interrupt Enable bit in the Processor Status and Control Register. Next, the interrupt latch of the current interrupt is cleared. This is followed by a CALL instruction to the ROM address associated with the interrupt being serviced (i.e., the Interrupt Vector). The instruction in the interrupt table is typically a JMP instruction to the address of the Interrupt Service Routine (ISR). The user can re-enable interrupts in the interrupt service routine by executing an EI instruction. Interrupts can be nested to a level limited only by the available stack space.

The Program Counter value as well as the Carry and Zero flags (CF, ZF) are automatically stored onto the Program Stack by the CALL instruction as part of the interrupt acknowledge process. The user firmware is responsible for insuring that the processor state is preserved and restored during an interrupt. The PUSH A instruction should be used as the first command in the ISR to save the accumulator value and the POP A instruction should be used just before the RETI instruction to restore the accumulator value. The program counter CF and ZF are restored and interrupts are enabled when the RETI instruction is executed.



Table 25. USB End Point Interrupt Enable Register

Addr: 0x21		USB End Point Interrupt Enable Register					
7	6	5	4	3	2	1	0
Reserved	Reserved	Reserved	Reserved	Reserved	EPA2 Interrupt Enable	EPA1 Interrupt Enable	EPA0 Interrupt Enable
					R/W	R/W	R/W

Interrupt Vectors

The Interrupt Vectors supported by the USB Controller are listed in Table 26. Although Reset is not an interrupt, per se, the first instruction executed after a reset is at PROM address 0x0000—which corresponds to the first entry in the Interrupt Vector Table. Because the JMP instruction is 2 bytes long, the interrupt vectors occupy 2 bytes.

Table 26. Interrupt Vector Assignments

Interrupt Vector Number	ROM Address	Function
not applicable	0x0000	Execution after Reset begins here
1	0x0002	USB Bus Reset interrupt
2	0x0004	128-μs timer interrupt
3	0x0006	1.024-ms timer interrupt
4	0x0008	USB Address A Endpoint 0 interrupt
5	0x000A	USB Address A Endpoint 1 interrupt
6	0x000C	USB Address A Endpoint 2 interrupt
7	0x000E	Reserved
8	0x0010	Reserved
9	0x0012	Reserved
10	0x0014	DAC interrupt
11	0x0016	GPIO interrupt
12	0x0018	Reserved

Interrupt Latency

Interrupt latency can be calculated from the following equation:

$$\text{Interrupt Latency} = (\text{Number of clock cycles remaining in the current instruction}) + (10 \text{ clock cycles for the CALL instruction}) + (5 \text{ clock cycles for the JMP instruction})$$

For example, if a 5 clock cycle instruction such as JC is being executed when an interrupt occurs, the first instruction of the Interrupt Service Routine will execute a min. of 16 clocks (1+10+5) or a max. of 20 clocks (5+10+5) after the interrupt is issued. Remember that the interrupt latches are sampled at the rising edge of the last clock cycle in the current instruction.

USB Bus Reset Interrupt

The USB Bus Reset interrupt is asserted when a USB bus reset condition is detected. A USB bus reset is indicated by a single ended zero (SE0) on the upstream port for more than 8 microseconds.

Timer Interrupt

There are two timer interrupts: the 128-μs interrupt and the 1.024-ms interrupt. The user should disable both timer interrupts

before going into the suspend mode to avoid possible conflicts between servicing the interrupts first or the suspend request first.

USB Endpoint Interrupts

There are three USB endpoint interrupts, one per endpoint. The USB endpoints interrupt after the either the USB host or the USB controller sends a packet to the USB.

DAC Interrupt

Each DAC I/O pin can generate an interrupt, if enabled. The interrupt polarity for each DAC I/O pin is programmable. A positive polarity is a rising edge input while a negative polarity is a falling edge input. All of the DAC pins share a single interrupt vector, which means the firmware will need to read the DAC port to determine which pin or pins caused an interrupt.

Please note that if one DAC pin triggered an interrupt, no other DAC pins can cause a DAC interrupt until that pin has returned to its inactive (non-trigger) state or the corresponding interrupt enable bit is cleared. The USB Controller does not assign interrupt priority to different DAC pins and the DAC Interrupt Enable Register is not cleared during the interrupt acknowledge process.



GPIO Interrupt

Each of the 32 GPIO pins can generate an interrupt, if enabled. The interrupt polarity can be programmed for each GPIO port as part of the GPIO configuration. All of the GPIO pins share a single interrupt vector, which means the firmware will need to read the GPIO ports with enabled interrupts to determine which pin or pins caused an interrupt.

Please note that if one port pin triggered an interrupt, no other port pins can cause a GPIO interrupt until that port pin has returned to its inactive (non-trigger) state or its corresponding port interrupt enable bit is cleared. The USB Controller does not assign interrupt priority to different port pins and the Port Interrupt Enable Registers are not cleared during the interrupt acknowledge process.

Truth Tables

Table 27. USB Register Mode Encoding

Mode	Encoding	Setup	In	Out	Comments
Disable	0000	ignore	ignore	ignore	Ignore all USB traffic to this endpoint
Nak In/Out	0001	accept	NAK	NAK	Forced from Set-up on Control endpoint, from modes other than 0000
Status Out Only	0010	accept	stall	check	For Control endpoints
Stall In/Out	0011	accept	stall	stall	For Control endpoints
Ignore In/Out	0100	accept	ignore	ignore	For Control endpoints
Isochronous Out	0101	ignore	ignore	always	Available to low speed devices, future USB spec enhancements
Status In Only	0110	accept	TX 0	stall	For Control Endpoints
Isochronous In	0111	ignore	TX cnt	ignore	Available to low speed devices, future USB spec enhancements
Nak Out	1000	ignore	ignore	NAK	An ACK from mode 1001 --> 1000
Ack Out	1001	ignore	ignore	ACK	This mode is changed by SIE on issuance of ACK --> 1000
Nak Out - Status In	1010	accept	TX 0	NAK	An ACK from mode 1011 --> 1010
Ack Out - Status In	1011	accept	TX 0	ACK	This mode is changed by SIE on issuance of ACK --> 1010
Nak In	1100	ignore	NAK	ignore	An ACK from mode 1101 --> 1100
Ack In	1101	ignore	TX cnt	ignore	This mode is changed by SIE on issuance of ACK --> 1100
Nak In - Status Out	1110	accept	NAK	check	An ACK from mode 1111 --> 1110 NAK In - Status Out
Ack In - Status Out	1111	accept	TX cnt	Check	This mode is changed by SIE on issuance of ACK -->1110

The 'In' column represents the SIE's response to the token type. A disabled endpoint will remain such until firmware changes it, and all endpoints reset to disabled.

Any Setup packet to an enabled and accepting endpoint will be changed by the SIE to 0001 (NAKing). Any mode which indicates the acceptance of a Setup will acknowledge it.

Most modes that control transactions involving an ending ACK will be changed by the SIE to a corresponding mode which NAKs follow on packets.

A Control endpoint has three extra status bits for PID (Setup, In and Out), but must be placed in the correct mode to function as such. Also a non-Control endpoint can be made to act as a Control endpoint if it is placed in a non appropriate mode.

A 'check' on an Out token during a Status transaction checks to see that the Out is of zero length and has a Data Toggle (DTOG) of 1.



Figure 7. Decode table for Table 28: “Details of Modes for Differing Traffic Conditions”

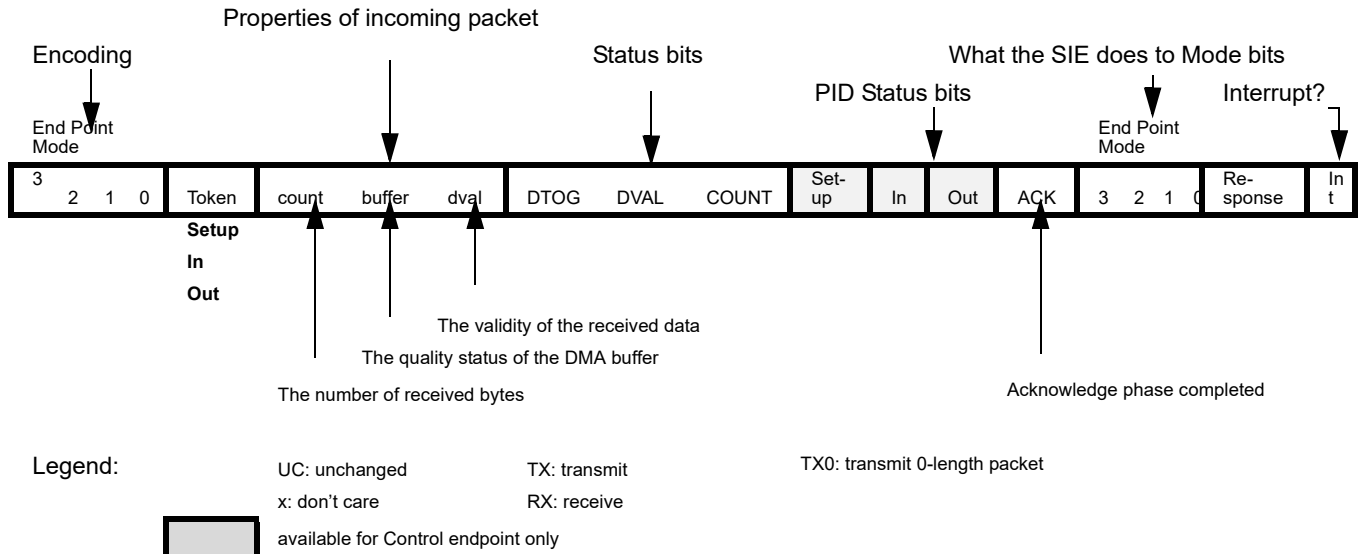

- The response of the SIE can be summarized as follows:
1. the SIE will only respond to valid transactions, and will ignore non-valid ones;
 2. the SIE will generate IRQ when a valid transaction is completed or when the DMA buffer is corrupted
 3. an incoming Data packet is valid if the count is ≤ 10 (CRC inclusive) and passes all error checking;
 4. a Setup will be ignored by all non-Control endpoints (in appropriate modes);
 5. an In will be ignored by an Out configured endpoint and vice versa.
- The In and Out PID status is updated at the end of a transaction.

The Setup PID status is updated at the beginning of the Data packet phase.

The entire EndPoint 0 mode and the Count register are locked to CPU writes at the end of any transaction in which an ACK is transferred. These registers are only unlocked upon a CPU read of these registers, and only if that read happens after the transaction completes. This represents about a 1- μ s window to which to the CPU is locked from register writes to these USB registers. Normally the firmware does a register read at the beginning of the ISR to unlock and get the mode register information. The interlock on the Mode and Count registers ensures that the firmware recognizes the changes that the SIE might have made during the previous transaction.



Table 28. Details of Modes for Differing Traffic Conditions

End Point Mode											PID				Set End Point Mode					
3	2	1	0	token	count	buffer	dval	DTOG	DVAL	COUNT	Setup	In	Out	ACK	3	2	1	0	response	int
Setup Packet (if accepting)																				
See Table 27	Setup	<= 10	data	valid	updates	1	updates	1	UC	UC	1	0	0	0	1	ACK	yes			
See Table 27	Setup	> 10	junk	x	updates	updates	updates	1	UC	UC	UC	NoChange				ignore	yes			
See Table 27	Setup	x	junk	invalid	updates	0	updates	1	UC	UC	UC	NoChange				ignore	yes			
Disabled																				
0	0	0	0	x	x	UC	x	UC	UC	UC	UC	UC	UC	UC	UC	NoChange	ignore	no		
Nak In/Out																				
0	0	0	1	Out	x	UC	x	UC	UC	UC	UC	UC	1	UC	NoChange	NAK	yes			
0	0	0	1	In	x	UC	x	UC	UC	UC	UC	1	UC	UC	NoChange	NAK	yes			
Ignore In/Out																				
0	1	0	0	Out	x	UC	x	UC	UC	UC	UC	UC	UC	UC	NoChange	ignore	no			
0	1	0	0	In	x	UC	x	UC	UC	UC	UC	UC	UC	UC	NoChange	ignore	no			
Stall In/Out																				
0	0	1	1	Out	x	UC	x	UC	UC	UC	UC	UC	1	UC	NoChange	Stall	yes			
0	0	1	1	In	x	UC	x	UC	UC	UC	UC	1	UC	UC	NoChange	Stall	yes			
Control Write																				
Normal Out/premature status In																				
1	0	1	1	Out	<= 10	data	valid	updates	1	updates	UC	UC	1	1	1	0	1	0	ACK	yes
1	0	1	1	Out	> 10	junk	x	updates	updates	updates	UC	UC	1	UC	NoChange				ignore	yes
1	0	1	1	Out	x	junk	invalid	updates	0	updates	UC	UC	1	UC	NoChange				ignore	yes
1	0	1	1	In	x	UC	x	UC	UC	UC	UC	1	UC	1	NoChange				TX 0	yes
NAK Out/premature status In																				
1	0	1	0	Out	<= 10	UC	valid	UC	UC	UC	UC	UC	1	UC	NoChange				NAK	yes
1	0	1	0	Out	> 10	UC	x	UC	UC	UC	UC	UC	UC	UC	NoChange				ignore	no
1	0	1	0	Out	x	UC	invalid	UC	UC	UC	UC	UC	UC	UC	NoChange				ignore	no
1	0	1	0	In	x	UC	x	UC	UC	UC	UC	1	UC	1	NoChange				TX 0	yes
Status In/extra Out																				
0	1	1	0	Out	<= 10	UC	valid	UC	UC	UC	UC	UC	1	UC	0	0	1	1	Stall	yes
0	1	1	0	Out	> 10	UC	x	UC	UC	UC	UC	UC	UC	UC	NoChange				ignore	no
0	1	1	0	Out	x	UC	invalid	UC	UC	UC	UC	UC	UC	UC	NoChange				ignore	no
0	1	1	0	In	x	UC	x	UC	UC	UC	UC	1	UC	1	NoChange				TX 0	yes
Control Read																				
Normal In/premature status Out																				
1	1	1	1	Out	2	UC	valid	1	1	updates	UC	UC	1	1	NoChange				ACK	yes
1	1	1	1	Out	2	UC	valid	0	1	updates	UC	UC	1	UC	0	0	1	1	Stall	yes
1	1	1	1	Out	!=2	UC	valid	updates	1	updates	UC	UC	1	UC	0	0	1	1	Stall	yes
1	1	1	1	Out	> 10	UC	x	UC	UC	UC	UC	UC	UC	UC	NoChange				ignore	no
1	1	1	1	Out	x	UC	invalid	UC	UC	UC	UC	UC	UC	UC	NoChange				ignore	no
1	1	1	1	In	x	UC	x	UC	UC	UC	UC	1	UC	1	1	1	1	0	ACK (back)	yes
Nak In/premature status Out																				
1	1	1	0	Out	2	UC	valid	1	1	updates	UC	UC	1	1	NoChange				ACK	yes
1	1	1	0	Out	2	UC	valid	0	1	updates	UC	UC	1	UC	0	0	1	1	Stall	yes
1	1	1	0	Out	!=2	UC	valid	updates	1	updates	UC	UC	1	UC	0	0	1	1	Stall	yes
1	1	1	0	Out	> 10	UC	x	UC	UC	UC	UC	UC	UC	UC	NoChange				ignore	no
1	1	1	0	Out	x	UC	invalid	UC	UC	UC	UC	UC	UC	UC	NoChange				ignore	no
1	1	1	0	In	x	UC	x	UC	UC	UC	UC	1	UC	UC	NoChange				NAK	yes
Status Out/extra In																				
0	0	1	0	Out	2	UC	valid	1	1	updates	UC	UC	1	1	NoChange				ACK	yes



Table 28. Details of Modes for Differing Traffic Conditions (continued)

End Point Mode											PID				Set End Point Mode					
3	2	1	0	token	count	buffer	dval	DTOG	DVAL	COUNT	Setup	In	Out	ACK	3	2	1	0	response	int
0	0	1	0	Out	2	UC	valid	0	1	updates	UC	UC	1	UC	0	0	1	1	Stall	yes
0	0	1	0	Out	!=2	UC	valid	updates	1	updates	UC	UC	1	UC	0	0	1	1	Stall	yes
0	0	1	0	Out	> 10	UC	x	UC	UC	UC	UC	UC	UC	UC	UC	UC	UC	UC	ignore	no
0	0	1	0	Out	x	UC	invalid	UC	UC	UC	UC	UC	UC	UC	UC	UC	UC	UC	ignore	no
0	0	1	0	In	x	UC	x	UC	UC	UC	UC	1	UC	UC	0	0	1	1	Stall	yes
Out endpoint																				
Normal Out/erroneous In																				
1	0	0	1	Out	<= 10	data	valid	updates	1	updates	UC	UC	1	1	1	0	0	0	ACK	yes
1	0	0	1	Out	> 10	junk	x	updates	updates	updates	UC	UC	1	UC	NoChange				ignore	yes
1	0	0	1	Out	x	junk	invalid	updates	0	updates	UC	UC	1	UC	NoChange				ignore	yes
1	0	0	1	In	x	UC	x	UC	UC	UC	UC	UC	UC	UC	NoChange				ignore	no
NAK Out/erroneous In																				
1	0	0	0	Out	<= 10	UC	valid	UC	UC	UC	UC	UC	1	UC	NoChange				NAK	yes
1	0	0	0	Out	> 10	UC	x	UC	UC	UC	UC	UC	UC	UC	NoChange				ignore	no
1	0	0	0	Out	x	UC	invalid	UC	UC	UC	UC	UC	UC	UC	NoChange				ignore	no
1	0	0	0	In	x	UC	x	UC	UC	UC	UC	UC	UC	UC	NoChange				ignore	no
Isochronous endpoint (Out)																				
0	1	0	1	Out	x	updates	updates	updates	updates	updates	UC	UC	1	1	NoChange				RX	yes
0	1	0	1	In	x	UC	x	UC	UC	UC	UC	UC	UC	UC	NoChange				ignore	no
In endpoint																				
Normal In/erroneous Out																				
1	1	0	1	Out	x	UC	x	UC	UC	UC	UC	UC	UC	UC	NoChange				ignore	no
1	1	0	1	In	x	UC	x	UC	UC	UC	UC	1	UC	1	1	1	0	0	ACK (back)	yes
NAK In/erroneous Out																				
1	1	0	0	Out	x	UC	x	UC	UC	UC	UC	UC	UC	UC	NoChange				ignore	no
1	1	0	0	In	x	UC	x	UC	UC	UC	UC	1	UC	UC	NoChange				NAK	yes
Isochronous endpoint (In)																				
0	1	1	1	Out	x	UC	x	UC	UC	UC	UC	UC	UC	UC	NoChange				ignore	no
0	1	1	1	In	x	UC	x	UC	UC	UC	UC	1	UC	UC	NoChange				TX	yes



Absolute Maximum Ratings

Storage temperature	-65 °C to +150 °C
Ambient temperature with power applied	-0 °C to +70 °C
Supply voltage on V _{CC} relative to V _{SS}	-0.5 V to +7.0 V
DC input voltage	-0.5 V to +V _{CC} +0.5 V

DC voltage applied to outputs in High Z state	-0.5 V to + V _{CC} +0.5 V
Maximum output current into Port 0,1,2,3 and DAC[1:0] Pins	60 mA
Maximum output current into DAC[7:2] Pins	10 mA
Power dissipation	300 mW
Static discharge voltage	> 2000V ^[3]
Latch-up current	> 200 mA

DC Characteristics

Fosc = 6 MHz; operating temperature = 0 to 70 °C

	Parameter	Min	Max	Unit	Conditions
General					
V _{CC(1)}	Operating voltage	4.0	5.5	V	Non USB activity ^[4]
V _{CC(2)}	Operating voltage	4.35	5.25	V	USB activity ^[5]
I _{CC1}	V _{CC} operating supply current	-	40	mA	V _{CC} = 5.5 V
I _{CC2}	V _{CC} = 4.35 V	-	15	mA	-
I _{SB1}	Supply current - suspend mode	-	30	μA	Oscillator off, D- > Voh min
V _{PP}	Programming voltage (disabled)	-0.4	0.4	V	-
T _{start}	Resonator start-up interval	-	256	μs	V _{CC} = 5.0 V, ceramic resonator
t _{int1}	Internal timer #1 interrupt period	128	128	μs	-
t _{int2}	Internal timer #2 interrupt period	1.024	1.024	ms	-
t _{watch}	Watch dog timer period	8.192	14.33	ms	-
I _{il}	Input leakage current	-	1	μA	Any pin
I _{sm}	Max I _{SS} I/O sink current	-	60	mA	Cumulative across all ports ^[6]
Power-On Reset					
t _{vccs}	V _{CC} reset slew	0.001	200	ms	Linear ramp: 0 to 4.35 V ^[7, 8]
USB Interface					
V _{oh}	Static output HIGH	2.8	3.6	V	15 k ± 5% Ω to Gnd ^[5]
V _{ol}	Static output LOW	-	0.3	V	-
V _{di}	Differential input sensitivity	0.2		V	(D+)-(D-)
V _{cm}	Differential input common mode range	0.8	2.5	V	9-1
V _{se}	Single-ended receiver threshold	0.8	2.0	V	-
C _{in}	Transceiver capacitance	-	20	pF	-
I _{lo}	Hi-Z state data line leakage	-10	10	μA	0 V < V _{in} < 3.3 V
R _{pu}	Bus pull-up resistance (V _{CC} option)	7.35K	7.65	kΩ	7.5 kΩ ± 2% to V _{CC}
R _{pu}	Bus pull-up resistance (Ext. 3.3 V option)	1.425	1.575	kΩ	1.5 kΩ ± 5% to 3.0-3.6 V
R _{pd}	Bus pull-down resistance	14.25	15.75	kΩ	15 kΩ ± 5%
General Purpose I/O Interface					
R _{up}	Pull-up resistance	4.9 K	9.1 K	Ohms	-
V _{ith}	Input threshold voltage	45%	65%	V _{CC}	All ports, LOW to HIGH edge

Notes

3. Qualified with JEDEC EIA/JESD22-A114-B test method.
4. Functionality is guaranteed of the V_{CC(1)} range, except USB transmitter and DACs.
5. USB transmitter functionality is guaranteed over the V_{CC(2)} range, as well as DAC outputs.
6. Total current cumulative across all Port pins flowing to V_{SS} is limited to minimize Ground-Drop noise effects.
7. Port 3 bit 7 controls whether the parts goes into suspend after a POR event or waits 128 ms to begin running.
8. POR will re-occur whenever V_{CC} drops to approximately 2.5 V.



DC Characteristics

Fosc = 6 MHz; operating temperature = 0 to 70 °C (continued)

	Parameter	Min	Max	Unit	Conditions
V_H	Input hysteresis voltage	6%	12%	V_{CC}	All ports, HIGH to LOW edge
I_{ol}	Sink current	7.2	16.5	mA	Port 3, $V_{out} = 1.0\text{ V}^{[9]}$
I_{ol}	Sink current	3.5	10.6	mA	Port 0,1,2, $V_{out} = 2.0\text{ V}^{[9]}$
I_{oh}	Source current	1.4	7.5	mA	$V_{oh} = 2.4\text{ V}$ (all ports 0,1,2,3) ^[9]
DAC Interface					
R_{up}	Pull-up resistance	8.0 K	20.0 K	Ohms	Note16
$I_{sink0(0)}$	DAC[7:2] sink current (0) ^[17]	0.1	0.3	mA	$V_{out} = 2.0\text{ VDC}^{[10]}$
$I_{sink0(F)}$	DAC[7:2] sink current (F) ^[17]	0.5	1.5	mA	$V_{out} = 2.0\text{ DC}^{[10]}$
$I_{sink1(0)}$	DAC[1:0] sink current (0) ^[17]	1.6	4.8	mA	$V_{out} = 2.0\text{ VDC}^{[10]}$
$I_{sink1(F)}$	DAC[1:0] sink current (F) ^[17]	8	24	mA	$V_{out} = 2.0\text{ VDC}^{[10]}$
I_{range}	Programmed Isink ratio: max/min	4	6	–	$V_{out} = 2.0\text{ VDC}^{[10,14]}$
I_{lin}	Differential nonlinearity	–	0.5	lsb	Any pin ^[12]
t_{sink}	Current sink response time	–	0.8	μs	Full scale transition
T_{ratio}	Tracking ratio DAC[1:0] to DAC[7:2]	14	21	–	$V_{out} = 2.0\text{ V}^{[13]}$



Switching Characteristics

Parameter	Description	Min	Max	Unit	Conditions
Clock					
t_{CYC}	Input Clock Cycle Time	165.0	168.3	ns	–
t_{CH}	Clock HIGH Time	0.45 t_{CYC}	–	ns	–
t_{CL}	Clock LOW Time	0.45 t_{CYC}	–	ns	–
USB Driver Characteristics					
t_r	Transition Rise Time	75	–	ns	$C_{Load} = 50 \text{ pF}^{[10, 11]}$
t_r	Transition Rise Time	–	300	ns	$C_{Load} = 600 \text{ pF}^{[10, 11]}$
t_f	Transition Fall Time	75	–	ns	$C_{Load} = 50 \text{ pF}^{[10, 11]}$
t_f	Transition Fall Time	–	300	ns	$C_{Load} = 600 \text{ pF}^{[10, 11]}$
t_{rfm}	Rise/Fall Time Matching	80	125	%	$t_r/t_f^{[10, 11]}$
V_{crs}	Output Signal Crossover Voltage	1.3	2.0	V	Notes 10 and 11
USB Data Timing					
t_{drate}	Low Speed Data Rate	1.4775	1.5225	Mbs	Ave. Bit Rate (1.5 Mb/s \pm 1.5%)
t_{djr1}	Receiver Data Jitter Tolerance	–75	75	ns	To Next Transition ^[15]
t_{djr2}	Receiver Data Jitter Tolerance	–45	45	ns	For Paired Transitions ^[15]
t_{deop}	Differential to EOP Transition Skew	–40	100	ns	Note 18
t_{eopr1}	EOP Width at Receiver	330	–	ns	Rejects as EOP ^[15]
t_{eopr2}	EOP Width at Receiver	675	–	ns	Accepts as EOP ^[15]
t_{eopt}	Source EOP Width	1.25	1.50	μs	–
t_{udj1}	Differential Driver Jitter	–95	95	ns	To next transition, Figure 12 on page 33 .
t_{udj2}	Differential Driver Jitter	–150	150	ns	To paired transition, Figure 12 on page 33 .

Notes

9. Functionality is guaranteed of the $V_{CC(1)}$ range, except USB transmitter and DACs.
10. USB transmitter functionality is guaranteed over the $V_{CC(2)}$ range, as well as DAC outputs.
11. Per Table 7-7 of revision 1.1 of USB specification, for C_{LOAD} of 50–600 pF.
12. Measured as largest step size vs. nominal according to measured full scale and zero programmed values.
13. $T_{ratio} = I_{sink1}[1:0](n)/I_{sink0}[7:2](n)$ for the same n, programmed.
14. Irange: $I_{sinkn}(15)/I_{sinkn}(0)$ for the same pin.
15. Measured at crossover point of differential data signals.
16. Limits total bus capacitance loading (C_{LOAD}) to 400 pF per section 7.1.5 of revision 1.1 of USB specification.
17. DAC I/O Port not bonded out on CY7C63613C. See note on page 12 for firmware code needed for unused pins.
18. Total current cumulative across all Port pins flowing to V_{SS} is limited to minimize Ground-Drop noise effects.



Figure 8. Clock Timing

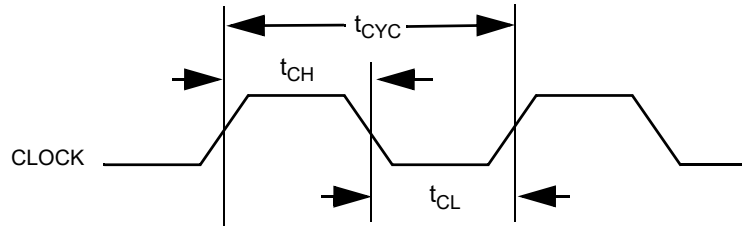

Figure 9. USB Data Signal Timing

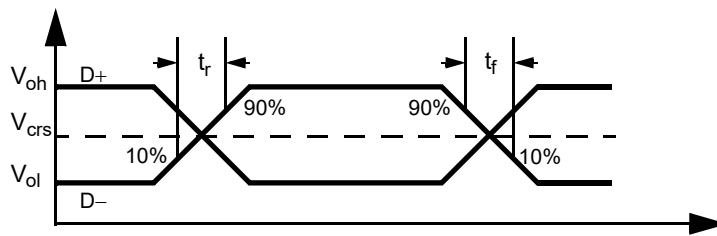

Figure 10. Receiver Jitter Tolerance

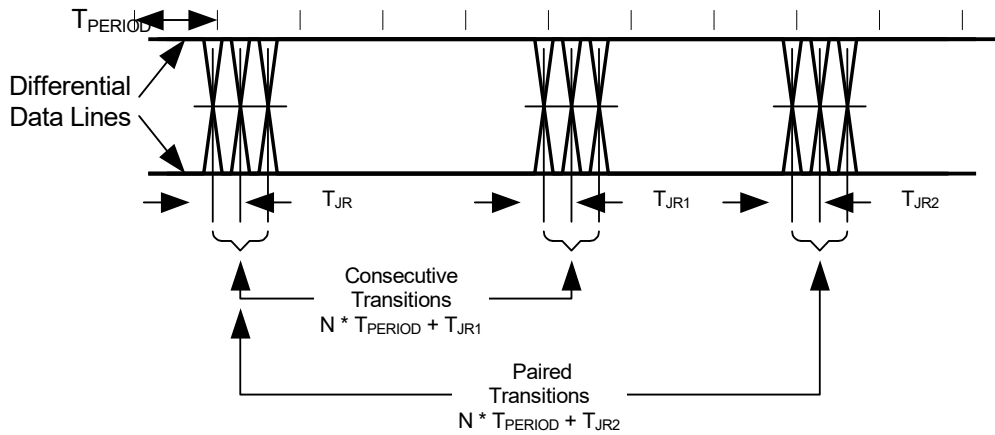



Figure 11. Differential to EOP Transition Skew and EOP Width

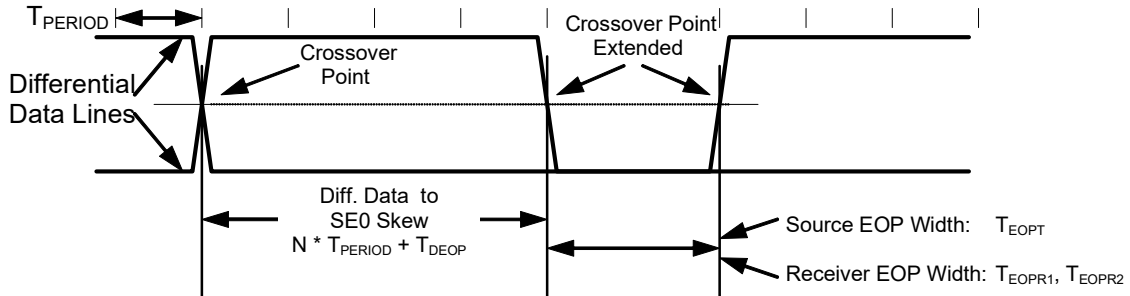
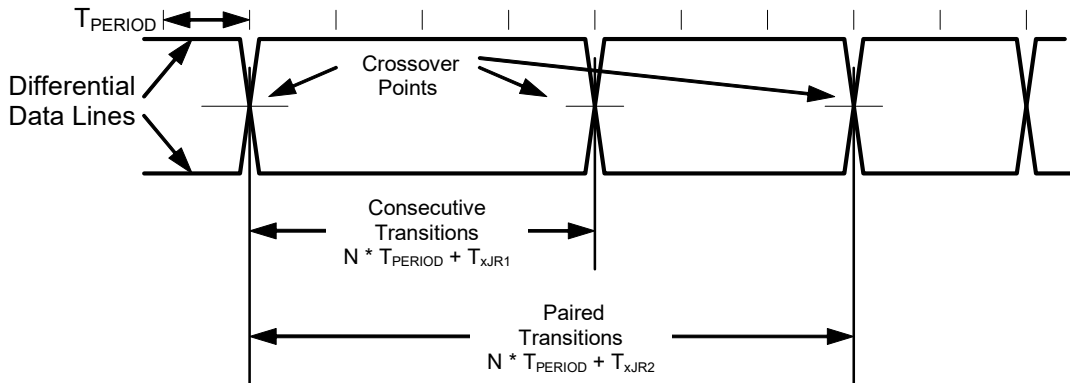

Figure 12. Differential Data Jitter





Ordering Information

Ordering Code	EPROM Size	Package Name	Package Type	Operating Range
CY7C63413C-PVXC	8 KB	SP48	48-pin Shrunken Small Outline Package	Commercial
CY7C63413C-PVXCT	8 KB	SP48	48-pin SSOP Pb-free Tape-reel	Commercial
CY7C63513C-PVXC	8 KB	SP48	48-pin SSOP Pb-free	Commercial
CY7C63613C-SXC	8 KB	SZ24.3	24-pin (300 mil) SOIC Pb-free	Commercial
CY7C63613C-SXCT	8 KB	SZ24.3	24-pin (300 mil) SOIC Pb-free Tape-reel	Commercial
CY7C63513C-PVXCT	8 KB	SP48	48-pin SSOP Pb-free Tape-reel	Commercial

Ordering Code Definitions

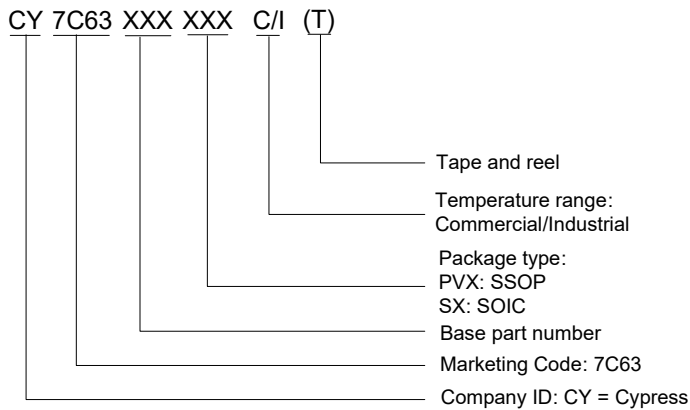



Package Diagrams

Figure 13. 48-pin SSOP (300 Mils) Package Outline, 51-85061

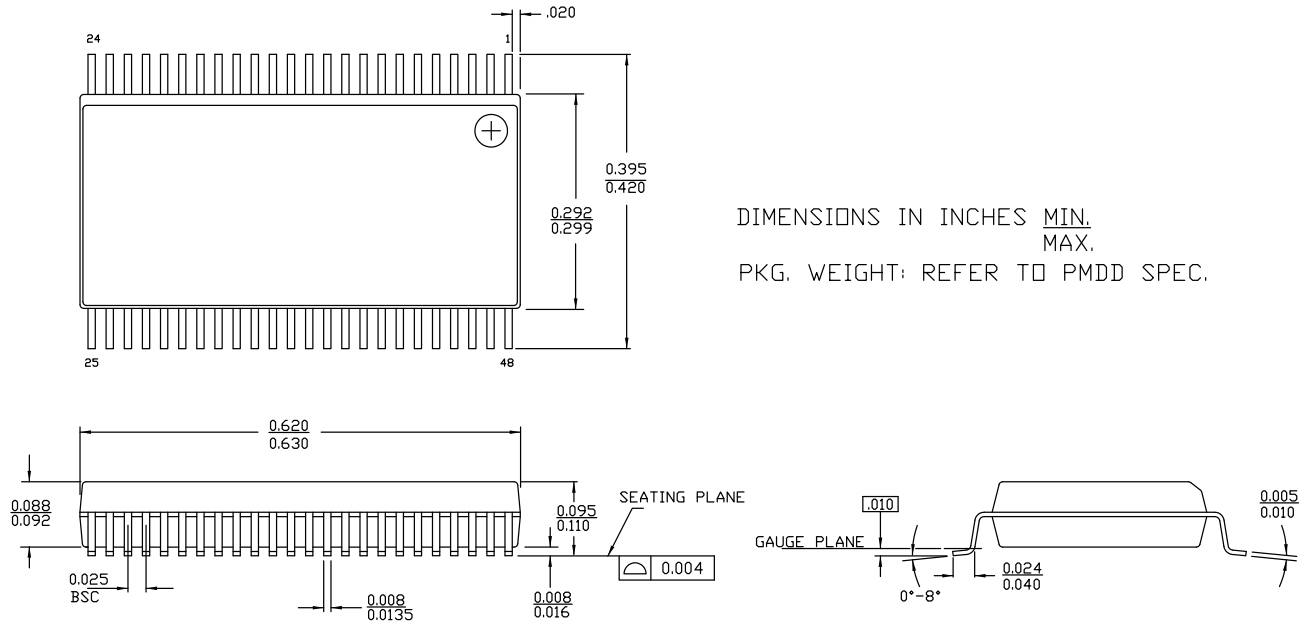

51-85061 *F

Figure 14. 24-pin SOIC (0.615 × 0.300 × 0.0932 Inches) Package Outline, 51-85025

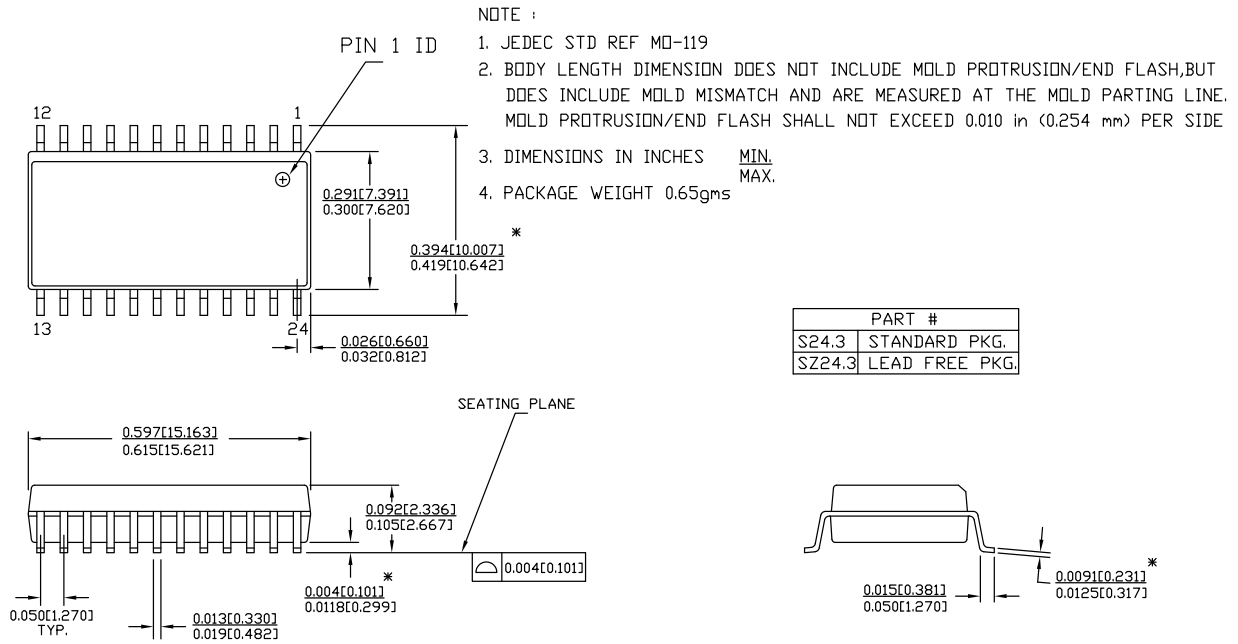

51-85025 *F



Acronyms

Acronym	Description	Acronym	Description
AC	Alternating current	PC	Program Counter
ADC	Analog-to-Digital Converter	PLL	Phase-Locked Loop
API	Application Programming Interface	POR	Power On Reset
CPU	Central Processing Unit	PPOR	Precision Power On Reset
CT	Continuous Time	PSoC®	Programmable System-on-Chip™
ECO	External Crystal Oscillator	PWM	Pulse Width Modulator
EEPROM	Electrically Erasable Programmable Read-Only Memory	SC	Switched Capacitor
FSR	Full Scale Range	SRAM	Static Random Access Memory
GPIO	General Purpose I/O	ICE	In-Circuit Emulator
GUI	Graphical User Interface	ILO	Internal Low Speed Oscillator
HBM	Human Body Model	IMO	Internal Main Oscillator
LSb	Least-Significant Bit	I/O	Input/Output
LVD	Low Voltage Detect	IPOR	Imprecise Power On Reset
MSb	Most-Significant Bit		

Document Conventions

Units of Measure

Symbol	Unit of Measure	Symbol	Unit of Measure
°C	degree Celsius	μW	microwatts
dB	decibels	mA	milliampere
fF	femto farad	ms	millisecond
Hz	hertz	mV	millivolts
KB	1024 bytes	nA	nanoampere
Kbit	1024 bits	ns	nanosecond
kHz	kilohertz	nV	nanovolts
kΩ	kilohm	W	ohm
MHz	megahertz	pA	picoampere
MΩ	megaohm	pF	picofarad
μA	microampere	pp	peak-to-peak
μF	microfarad	ppm	parts per million
μH	microhenry	ps	picosecond
μs	microsecond	sps	samples per second
μV	microvolts	s	sigma: one standard deviation
μVrms	microvolts root-mean-square	V	volts



Document History Page

Document Title: CY7C63413C/CY7C63513C/CY7C63613C, Low-Speed High Input/Output 1.5-Mbps USB Controller Document Number: 38-08027				
REV.	ECN No.	Orig. of Change	Submission Date	Description of Change
**	116224	DSG	06/12/2002	Changed spec number from 38-00754 to 38-08027.
*A	237148	KKU	07/15/2004	Added USB Logo in first page. Removed 24-pin SOIC package related information in all instances across the document. Removed CY7C63411, CY7C63412, CY7C63511, CY7C63512, CY7C63612 and CY7C63613 parts related information in all instances across the document. Updated Ordering Information : Updated part numbers.
*B	418699	TYJ	01/07/2006	Updated Ordering Information : Updated part numbers. Updated to new template.
*C	2896245	XUT	03/19/2010	Updated Ordering Information : Updated part numbers. Updated Package Diagrams : spec 51-85061 – Changed revision from *C to *D. spec 51-85019 – Changed revision from *A to *B. spec 51-85025 – Changed revision from *C to *D.
*D	3057657	AJHA	10/13/2010	Added watermark “Not Recommended for New Designs” across the document. Updated to new template.
*E	3130046	NXZ	01/18/2011	Updated Ordering Information : No change in part numbers. Added Ordering Code Definitions . Updated Package Diagrams : Removed spec 51-85019 *B. Added Acronyms and Units of Measure . Completing Sunset Review.
*F	4272762	DEJO	02/05/2014	Updated Package Diagrams : spec 51-85061 – Changed revision from *D to *F. spec 51-85025 – Changed revision from *D to *F. Updated to new template. Completing Sunset Review.
*G	4313900	AKSL	03/21/2014	Removed watermark “Not Recommended for New Designs” across the document. Updated Ordering Information : Updated part numbers. Completing Sunset Review.
*H	5647775	HPPC	03/02/2017	Updated to new template. Completing Sunset Review.
*I	6876204	HPPC	05/04/2020	Updated to new template. Completing Sunset Review.



Sales, Solutions, and Legal Information

Worldwide Sales and Design Support

Cypress maintains a worldwide network of offices, solution centers, manufacturer’s representatives, and distributors. To find the office closest to you, visit us at [Cypress Locations](#).

Products

Arm® Cortex® Microcontrollers	cypress.com/arm
Automotive	cypress.com/automotive
Clocks & Buffers	cypress.com/clocks
Interface	cypress.com/interface
Internet of Things	cypress.com/iot
Memory	cypress.com/memory
Microcontrollers	cypress.com/mcu
PSoC	cypress.com/psoc
Power Management ICs	cypress.com/pmic
Touch Sensing	cypress.com/touch
USB Controllers	cypress.com/usb
Wireless Connectivity	cypress.com/wireless

PSoC® Solutions

[PSoC 1](#) | [PSoC 3](#) | [PSoC 4](#) | [PSoC 5LP](#) | [PSoC 6 MCU](#)

Cypress Developer Community

[Community](#) | [Code Examples](#) | [Projects](#) | [Video](#) | [Blogs](#) | [Training](#) | [Components](#)

Technical Support

cypress.com/support

© Cypress Semiconductor Corporation, 2002–2020. This document is the property of Cypress Semiconductor Corporation and its subsidiaries (“Cypress”). This document, including any software or firmware included or referenced in this document (“Software”), is owned by Cypress under the intellectual property laws and treaties of the United States and other countries worldwide. Cypress reserves all rights under such laws and treaties and does not, except as specifically stated in this paragraph, grant any license under its patents, copyrights, trademarks, or other intellectual property rights. If the Software is not accompanied by a license agreement and you do not otherwise have a written agreement with Cypress governing the use of the Software, then Cypress hereby grants you a personal, non-exclusive, nontransferable license (without the right to sublicense) (1) under its copyright rights in the Software (a) for Software provided in source code form, to modify and reproduce the Software solely for use with Cypress hardware products, only internally within your organization, and (b) to distribute the Software in binary code form externally to end users (either directly or indirectly through resellers and distributors), solely for use on Cypress hardware product units, and (2) under those claims of Cypress’s patents that are infringed by the Software (as provided by Cypress, unmodified) to make, use, distribute, and import the Software solely for use with Cypress hardware products. Any other use, reproduction, modification, translation, or compilation of the Software is prohibited.

TO THE EXTENT PERMITTED BY APPLICABLE LAW, CYPRESS MAKES NO WARRANTY OF ANY KIND, EXPRESS OR IMPLIED, WITH REGARD TO THIS DOCUMENT OR ANY SOFTWARE OR ACCOMPANYING HARDWARE, INCLUDING, BUT NOT LIMITED TO, THE IMPLIED WARRANTIES OF MERCHANTABILITY AND FITNESS FOR A PARTICULAR PURPOSE. No computing device can be absolutely secure. Therefore, despite security measures implemented in Cypress hardware or software products, Cypress shall have no liability arising out of any security breach, such as unauthorized access to or use of a Cypress product. CYPRESS DOES NOT REPRESENT, WARRANT, OR GUARANTEE THAT CYPRESS PRODUCTS, OR SYSTEMS CREATED USING CYPRESS PRODUCTS, WILL BE FREE FROM CORRUPTION, ATTACK, VIRUSES, INTERFERENCE, HACKING, DATA LOSS OR THEFT, OR OTHER SECURITY INTRUSION (collectively, “Security Breach”). Cypress disclaims any liability relating to any Security Breach, and you shall and hereby do release Cypress from any claim, damage, or other liability arising from any Security Breach. In addition, the products described in these materials may contain design defects or errors known as errata which may cause the product to deviate from published specifications. To the extent permitted by applicable law, Cypress reserves the right to make changes to this document without further notice. Cypress does not assume any liability arising out of the application or use of any product or circuit described in this document. Any information provided in this document, including any sample design information or programming code, is provided only for reference purposes. It is the responsibility of the user of this document to properly design, program, and test the functionality and safety of any application made of this information and any resulting product. “High-Risk Device” means any device or system whose failure could cause personal injury, death, or property damage. Examples of High-Risk Devices are weapons, nuclear installations, surgical implants, and other medical devices. “Critical Component” means any component of a High-Risk Device whose failure to perform can be reasonably expected to cause, directly or indirectly, the failure of the High-Risk Device, or to affect its safety or effectiveness. Cypress is not liable, in whole or in part, and you shall and hereby do release Cypress from any claim, damage, or other liability arising from any use of a Cypress product as a Critical Component in a High-Risk Device. You shall indemnify and hold Cypress, its directors, officers, employees, agents, affiliates, distributors, and assigns harmless from and against all claims, costs, damages, and expenses, arising out of any claim, including claims for product liability, personal injury or death, or property damage arising from any use of a Cypress product as a Critical Component in a High-Risk Device. Cypress products are not intended or authorized for use as a Critical Component in any High-Risk Device except to the limited extent that (i) Cypress’s published data sheet for the product explicitly states Cypress has qualified the product for use in a specific High-Risk Device, or (ii) Cypress has given you advance written authorization to use the product as a Critical Component in the specific High-Risk Device and you have signed a separate indemnification agreement.

Cypress, the Cypress logo, Spansion, the Spansion logo, and combinations thereof, WICED, PSoC, CapSense, EZ-USB, F-RAM, and Traveo are trademarks or registered trademarks of Cypress in the United States and other countries. For a more complete list of Cypress trademarks, visit cypress.com. Other names and brands may be claimed as property of their respective owners.